

Klein®

S I S T E M I

HW, HS and DP tools for wood,
aluminium and plastic working
Measuring instruments
Catalog **19.A**

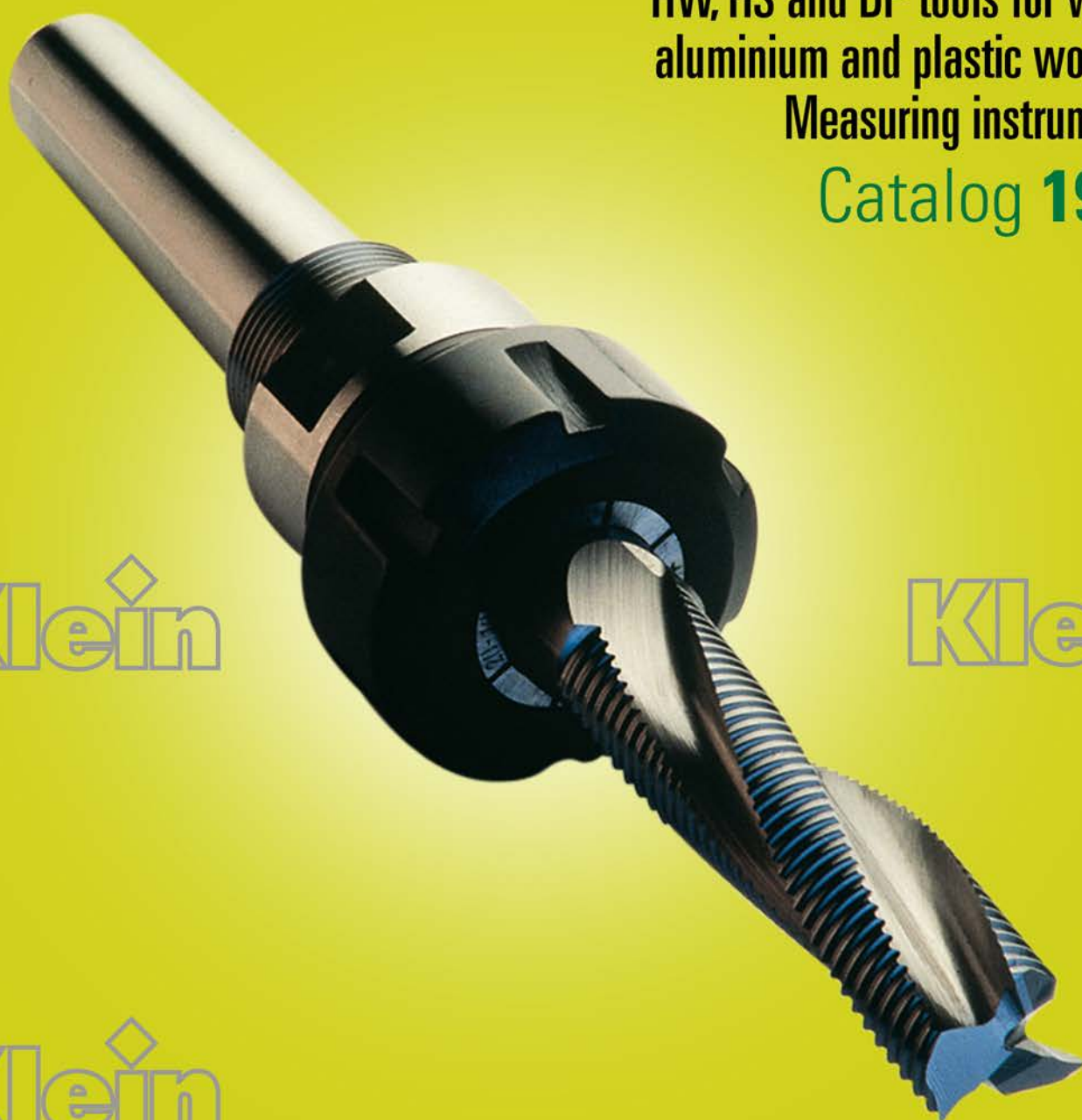

Klein

Klein

Klein

www.sistemiklein.com



With an **experience of over 40 years**, **Sistemi** has become a leading manufacturer of high quality tools for working wood, aluminium and plastics.

The brand **Klein** is synonymous of high quality tools thanks to continuous investment in the use of the latest technology and in training, with a more and more young and dynamic staff, consisting of technicians, designers and trade experts fully available to meet the multiple needs that global competition requires.

Sistemi exports its products today to more than **60 countries** around the world by consolidating its presence by the best retailers in the woodworking field and strengthening its success from year to year in order to start and develop continuously new projects, always with a view to "**customer satisfaction**".

The use of CAD together with an accurate selection of quality raw materials and a careful control performed with high precision instruments ensure the best performance of the tools, ensuring increasing productivity and a highly flexible response to any requests.

25 years of collaboration with the company m. conti have enabled us to offer also a wide range of measuring instruments for the furniture industry.

Since many years already **Sistemi** has become part of  **ACIMALL**, the Association that includes the main Italian manufacturers of machines and tools for woodworking.

www.sistemiklein.com

Explanation of symbols

| | | | |
|--------------------------------|---|----------------------------------|---|
| ■ Lock ring |  | ■ Softwood |  |
| ■ O-ring |  | ■ Hardwood |  |
| ■ Center bit |  | ■ Wood with small metal residues |  |
| ■ Allen keys |  | ■ MDF |  |
| ■ Torx keys |  | ■ Aluminium wood profiles |  |
| ■ Knives 2 cutting edges |  | ■ "Sandwich" panels |  |
| ■ Knives 4 cutting edges |  | ■ Single side laminated boards |  |
| ■ Spurs |  | ■ Double side laminated boards |  |
| ■ Profiled knives |  | ■ Single side veneer boards |  |
| ■ Versofix knives |  | ■ Double side veneer boards |  |
| ■ Hanging packaging |  | ■ Plastic coated materials |  |
| ■ Hanging packaging "Hobby" |  | ■ CORIAN® |  |
| ■ Shims |  | ■ Lumber |  |
| ■ Ball bearings |  | ■ Paper coated materials |  |
| ■ Spacers |  | ■ Plastic materials |  |
| ■ Threaded nuts |  | ■ Plexiglass |  |
| ■ Spurs |  | ■ Aluminium |  |
| ■ Washers |  | ■ Steel and ferrous materials |  |
| ■ Spring washers |  | ■ PVC |  |
| ■ Seeger |  | | |
| ■ Spacers |  | | |
| ■ Wedges |  | | |
| ■ Cheese head screws |  | | |
| ■ Countersunk head screws |  | | |
| ■ Allen screws |  | | |
| ■ Countersunk flat head screws |  | | |
| ■ Rounded head screws |  | | |
| ■ Slotted cheese head screws |  | | |
| ■ Screws for "Weeke" machines |  | | |

Catalogue sections

The catalogue is divided into **16** sections of which the first **14** dedicated to tools, the **n. 15** to measuring instruments and the **n.16** to special equipment.

| | |
|---|--|
| <p>1 pagg. 1.01-1.37 Router bits for hand portable machines S=Ø6 - S=Ø6,4 (1/4") - S=Ø8</p>  | <p>9 pagg. 9.01-9.31 Insert router bits and DP router bits</p>  |
| <p>2 pagg. 2.01-2.31 Router bits for hand portable machines S=Ø10 - S=Ø12 - S=Ø12,7 (1/2")</p>  | <p>10 pagg. 10.01-10.10 Spare Parts</p>  |
| <p>3 pagg. 3.01-3.10 Router bits for wood, chipboards and solid surface materials</p>  | <p>11 pagg. 11.01-11.17 Reversible knives and knives for planers</p>  |
| <p>4 pagg. 4.01-4.07 Router bits for handportable machines economy line</p>  | <p>12 pagg. 12.01-12.30 Sawblades</p>  |
| <p>5 pagg. 5.01-5.24 Dowel drills, boring bits for automatic boring machines</p>  | <p>13 pagg. 13.01-13.44 Cutterheads</p>  |
| <p>6 pagg. 6.01-6.15 Boring bits, slot mortising bits</p>  | <p>14 pagg. 14.01-14.10 Lubricants, diamond grinding wheels, diamond stones</p>  |
| <p>7 pagg. 7.01-7.53 Router bits and chucks for CNC routers</p>  | <p>15 pagg. 15.01-15.27 Measuring instruments</p>  |
| <p>8 pagg. 8.01-8.15 Router bits for aluminium and plastic working</p>  | <p>16 pagg. 16.01-16.21 Special devices</p>  |

Materials abbreviations (as per norm EN 847-1)

| | |
|------------|---|
| SP | Alloyed tool steel |
| HL | High-alloy tool steel |
| HS | High speed steel |
| HW | Uncoated hardmetal on tungsten carbide base |
| DP | Polycrystalline diamond |
| VHW | Solid tungsten carbide |

Technical abbreviations

| | | | |
|-------------|---|----------------|---|
| mm | Millimeter | MK3 | Collet chuck with morse taper shank (3) |
| Z | Number of teeth | Fori t. | Pin holes |
| Ø | Diameter | RPM | Rounds per minute |
| Sp. | Thickness | Nm | Newton / Meter |
| Rh | Right rotation | MAN | Manual feed |
| Lh | Left rotation | MEC | Mechanical feed |
| Mat. | Type of material | CNC | Computered Numerical Control |
| FF | Hollow end cap | DIN | German Industry Standard |
| FP | Extended end cap | ISO | International Organization of Standardization |
| MK2 | Collet chuck with morse taper shank (2) | | |

Router bits for hand portable machines
S=Ø6 - S=Ø6,4 (1/4") - S=Ø8



Klein

Router bits for hand portable machines
S=Ø10 - S=Ø12 - S=Ø12,7 (1/2")



Router bits for wood, chipboards
and solid surface materials



Router bits for handportable machines
economy line



Dowel drills, boring bits for
automatic boring machines



Boring bits, slot mortising bits



Router bits and chucks for CNC routers



Router bits for aluminium
and plastic working



1

2

3

4

5

6

7

8

Router bits for hand portable machines

S=Ø6 - S=Ø6,4 (1/4") - S=Ø8



1



VHW STRAIGHT BITS
Page 1.07



HW STRAIGHT BITS
Page 1.07



VHW DOUBLE FLUSH
TRIMMING BITS
Page 1.08



HW MORTISING PILOT BITS Z=2
Page 1.08

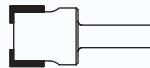

HW HINGE MORTISING BITS Z=2
Page 1.08



HW PANEL PILOT BITS Z=1+1
Page 1.08



HW DOUBLE PANEL PILOT BITS
Page 1.08

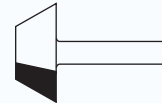

HW BEVEL TRIM BITS Z=2
Page 1.08



HW BEVEL TRIM BITS Z=2
Page 1.08



VHW DOVETAIL BITS Z=2
Page 1.09

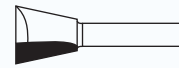

HW DOVETAIL BITS Z=2
Page 1.09

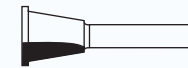

HW DOVETAIL BITS Z=2
Page 1.09



VHW U-GROOVE
AND SIGNMAKING BITS
Page 1.09

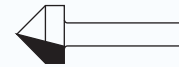

HW V-GROOVE AND SIGNMAKING BITS
Page 1.09

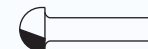

HW CORE BOX BITS Z=2
Page 1.10



HW PLUNGING
ROUND-OVER BITS Z=2
Page 1.10



HW PLUNGING ROUND-OVER BITS Z=2
Page 1.10

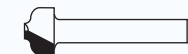

HW PLUNGE TYPE OGEE BITS Z=2
Page 1.10

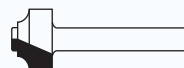

HW PLUNGE TYPE TRADITIONAL
BITS Z=2
Page 1.10

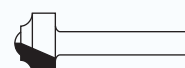

HW PLUNGE TYPE CLASSICAL
BITS Z=2
Page 1.10



HW BULL NOSE RADIUS BITS Z=2
Page 1.10

Klein[®]

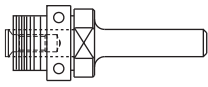

SLOT CUTTER ARBORS
Pag. 1.11

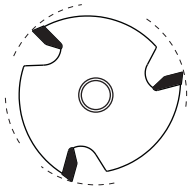

**HW SLOT CUTTERS SPECIAL
FIXING SCREW Z=3**
Pag. 1.11

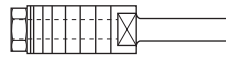

SLOT CUTTER ARBORS
Pag. 1.11

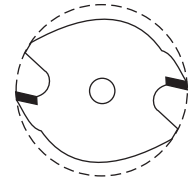

HW SLOT CUTTERS Z=2
Pag. 1.11

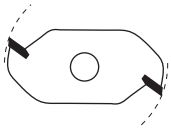

HW SLOT CUTTERS Z=2
Pag. 1.11

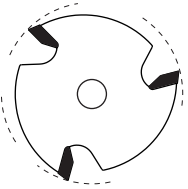

HW SLOT CUTTERS Z=3
Pag. 1.12



**HW TRIMMING BITS
WITH BALL BEARING Z=2**
Pag. 1.12



**HW TRIMMING BITS
WITH BALL BEARING Z=2**
Pag. 1.12

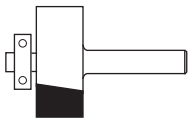

**HW RABBETTING BITS
WITH BALL BEARING Z=2**
Page 1.13

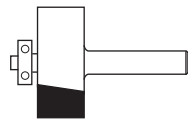

**HW RABBETTING BITS WITH
BALL BEARING Z=2**
Page 1.13

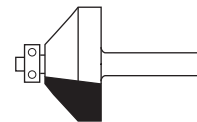

**HW BEVEL TRIM BITS
WITH BALL BEARING Z=2**
Page 1.13

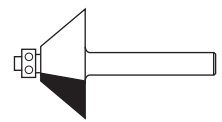

**HW BEVEL TRIM BIT GUIDE
WITH BALL BEARING**
Page 1.13

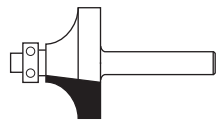

**HW CORNER ROUNDING BITS
WITH BALL BEARING Z=2**
Page 1.13

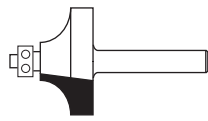

**HW BEADING BITS
WITH BALL BEARING GUIDE Z=2**
Page 1.14

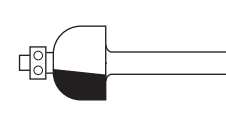

**HW COVER BITS
WITH BALL BEARING GUIDE Z=2**
Page 1.14

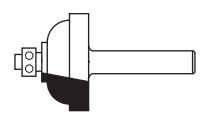

**HW CLASSICAL COVER BITS
WITH BALL BEARING GUIDE Z=2**
Page 1.14



**HW ROMAN OGEE BITS
WITH BALL BEARING GUIDE Z=2**
Page 1.14



HW DOUBLE ROMAN OGEE BITS Z=2
Page 1.14



**HW OGEE BITS
WITH BALL BEARING GUIDE Z=2**
Page 1.15

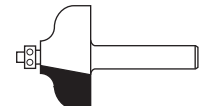

**HW OGEE BITS
WITH BALL BEARING GUIDE Z=2**
Page 1.15

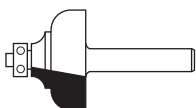

**HW OGEE BITS
WITH BALL BEARING GUIDE Z=2**
Page 1.15

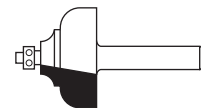

**HW OGEE BITS
WITH BALL BEARING GUIDE Z=2**
Page 1.15

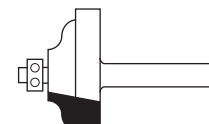

**HW OGEE BITS
WITH BALL BEARING GUIDE Z=2**
Page 1.15

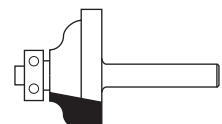

**HW OGEE BITS
WITH BALL BEARING GUIDE Z=2**
Page 1.15



**HW CLASSICAL MOULDING BITS
WITH BALL BEARING GUIDE Z=2**
Page 1.16



**HW CLASSICAL MOULDING BITS
WITH BALL BEARING GUIDE Z=2**
Page 1.16

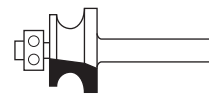

**HW CORNER BEADING BITS
WITH BALL BEARING GUIDE Z=2**
Page 1.16

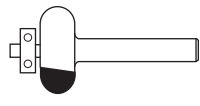

**HW EDGE-FLUTING BITS
WITH BALL BEARING GUIDE Z=2**
Page 1.16

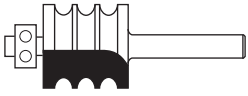

HW MULTI-BEADING BITS
WITH BALL BEARING GUIDE Z=2
Page 1.16

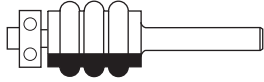

HW MULTI-BEADING BITS
WITH BALL BEARING GUIDE Z=2
Page 1.16

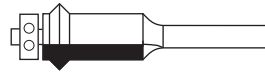

HW FLUSH-TRIM "V" GROOVE BITS
WITH BALL BEARING GUIDE Z=2
Page 1.17

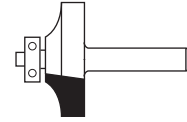

HW FLAT ROUNDING OVER BITS
WITH BALL BEARING GUIDE Z=2
Page 1.17

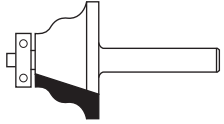

HW PROFILE BITS
WITH BALL BEARING GUIDE
Page 1.17

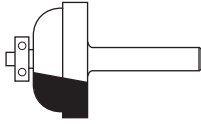

HW FLAT OGEE BITS WITH
BALL BEARING GUIDE Z=2
Page 1.17

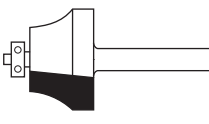

HW OVOLO JOINT BITS WITH
BALL BEARING GUIDE Z=2
Page 1.17

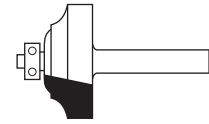

HW OGEE BITS
WITH BALL BEARING GUIDE Z=2
Page 1.18



HW PANEL PILOT BITS WITH
BALL BEARING GUIDE Z=1
Page 1.18



HW FLUSH AND BEVEL TRIM BITS Z=2
Page 1.18



HW FLUSH AND BEVEL TRIM BITS
WITH BALL BEARING GUIDE Z=2
Page 1.18

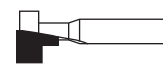

HW KEYHOLE BITS Z=1
Page 1.18

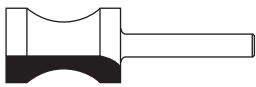

HW CONVEX EDGING BITS Z=2
Page 1.18

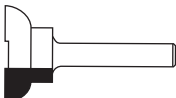

HW FINGER GRIP BITS Z=2
Page 1.18

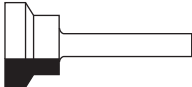

HW DRAWER LOCK BITS Z=2
Page 1.19



HW SEAL PROFILE BITS Z=2
Page 1.19



HW DOVETAIL SEAL BITS Z=2
Page 1.19

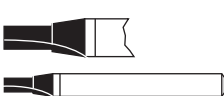

HW SEAL BITS Z=2
Page 1.19

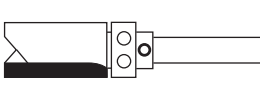

HW FLUSH TRIM BITS WITH
UPPER BALL BEARING GUIDE Z=2
Page 1.19

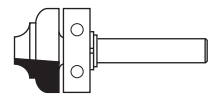

HW FLUSH TRIM BITS WITH
UPPER BALL BEARING GUIDE Z=2
Page 1.19

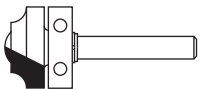

HW FLUSH TRIM BITS WITH
UPPER BALL BEARING GUIDE Z=2
Page 1.19

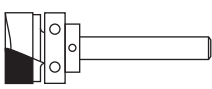

HW FLUSH TRIM BITS WITH
UPPER BALL BEARING GUIDE Z=2
Page 1.20

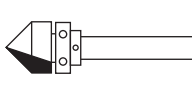

HW GROOVE BITS WITH
UPPER BALL BEARING GUIDE Z=2
Page 1.20

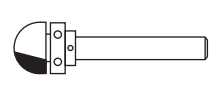

HW FLUSH TRIM BITS WITH
UPPER BALL BEARING GUIDE Z=2
Page 1.20

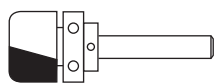

HW FLUSH TRIM BITS WITH
UPPER BALL BEARING GUIDE Z=2
Page 1.20

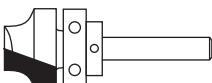

HW FLUSH TRIM BITS WITH
UPPER BALL BEARING GUIDE Z=2
Page 1.20

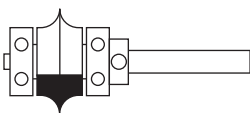

HW "LEAF-EDGE" BEADING BITS WITH
DOUBLE BALL BEARING GUIDE Z=2
Page 1.21

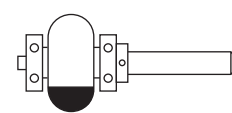

HW "EDGE-FLUTING" BITS WITH
DOUBLE BALL BEARING GUIDE Z=2
Page 1.21

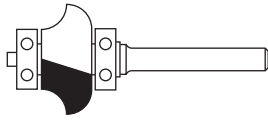

HW RADIUS BITS WITH DOUBLE BALL BEARING GUIDE Z=2
Page 1.21

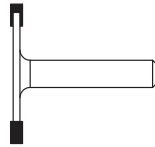

T-SLOT HW CUTTERS Z=4
Pag. 1.21



HW DOUBLE DIAMETER BITS Z=2
Page 1.21

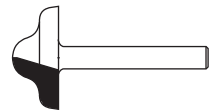

HW DOUBLE RADIUS BITS Z=2
Page 1.22



HW DOUBLE RADIUS BITS Z=2
Page 1.22

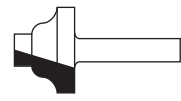

HW DOUBLE RADIUS BITS Z=2
Page 1.22

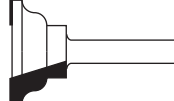

HW DOUBLE RADIUS BITS Z=2
Page 1.22

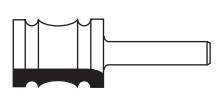

HW MULTI RADIUS BITS Z=2
Page 1.22

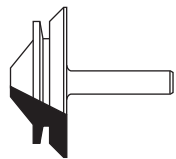

HW 45 DEGREE LOCK MITRE JOINT BITS Z=2
Page 1.22

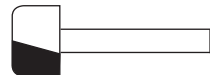

HW BOWL AND TRAY BITS Z=2
Page 1.22

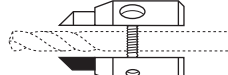

HW ADJUSTABLE COUNTERSINKS Z=2
Page 1.23

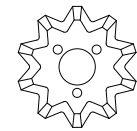

HS FLUSH TRIMMERS FOR TABLE EDGE BANDING MACHINES
Page 1.23

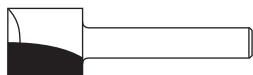

HW PLUNGE TYPE STRAIGHT BITS FOR "ELU"
Page 1.23

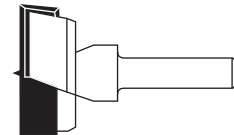

HW BORING BITS
Page 1.24

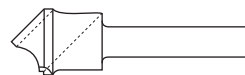

HSS COUNTERSINKS
Page 1.24



BUSHINGS
Page 1.24

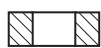

SPACERS
Page 1.24



HW INSERT FLUSH TRIMMING BITS Z=1
Page 1.25

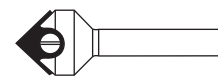

HW INSERT V-GROOVING BITS Z=1
Page 1.25

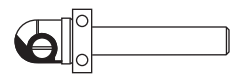

HW INSERT CORE BOX BITS WITH UPPER BALL BEARING Z=1
Page 1.25



HW INSERT FLUSH TRIMMING BITS WITH BALL BEARING
Page 1.25

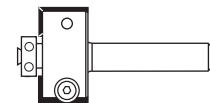

HW INSERT RABBIT BITS WITH BALL BEARING Z=2
Page 1.25

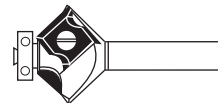

HW INSERT FLUSH TRIMMING BITS WITH BALL BEARING Z=2
Page 1.26

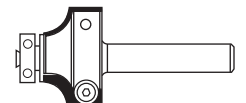

HW INSERT CORNER ROUNDING BITS WITH BALL BEARING Z=2
Page 1.26

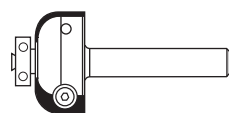

HW INSERT COVER BITS WITH BALL BEARING Z=2
Page 1.26

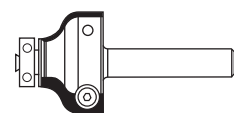

HW INSERT OGEE BITS WITH BALL BEARING Z=2
Page 1.26



6 PIECE STRAIGHT-DOVETAIL INSERT ROUTER BITS "STARTER SET"
Page 1.27



6 PIECE PROFILE INSERT ROUTER BITS "STARTER SET"
Page 1.27



6 PIECE STRAIGHT BITS
"STARTER SET"
Page 1.28



6 PIECE CORNER ROUNDING
BITS "STARTER SET"
Page 1.28



6 PIECE DOVETAIL BITS
"STARTER SET"
Page 1.29



12 PIECE CLASSICAL ROUTER
BITS "STARTER SET"
Page 1.30



12 PIECE STRAIGHT ROUTER
BITS "ADVANCED SET"
Page 1.31



12 PIECE PROFILE INSERT ROUTER BITS
"ADVANCED SET"
Page 1.32



12 PIECE DOVETAIL BITS
"ADVANCED SET"
Page 1.33



12 PIECE CORNER ROUNDING
BITS "ADVANCED SET"
Page 1.34



6 PIECE INSERT ROUTER BITS "SET"
Page 1.35



6 PIECE INSERT ROUTER BITS "SET"
Page 1.35



DISPLAY
Pag. 1.36

ROUTER BITS FOR PORTABLE ROUTERS

The high quality **Klein** router bits satisfy the most accurate applications required by the marketplace today. In order to achieve the highest level of quality, our production department has continually invested in and equipped with the advanced technologies and versatile engineering systems over the years.

Moreover we always pay detail attention to the choice of raw materials. For example, in developing our special TCT straight router bits, we collaborated with our supplier in material selection, so that these bits are produced for top market performance, precision and cutting life.

Various diameters and lengths of router bits can be found in our **Klein** catalogue; in fact, there are more than a thousand different items which can meet any particular requirement in both industrial and handcraft applications.

Table for the choice of straight router bits

| Items | Soft wood | Hard wood | Composite |
|-------------------------|-----------|-----------|-----------|
| A/B/C 101-102 VHW | XXX | XXX | XXX |
| A/B/C 101-102 HW brazed | XX | XXX | XXX |

VHW STRAIGHT BITS

ART. A101/2/3 - B101/2/3 - C101/2/3

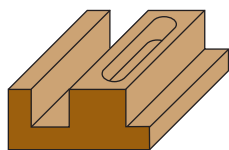
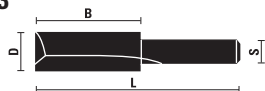

- Solid carbide
- Straight cut and plunging (Z=2+1)
- To be used also for working plastic materials, acrylic, polypropylene, acetates and polycarbonates
- To be used also for C.N.C. machines



| S Ø 6 | S Ø 6,4 (1/4") | S Ø 8 | D | B | L | Z |
|------------|----------------|------------|-----|----|----|-----|
| A101.015.R | | | 1,5 | 4 | 46 | 2+1 |
| A101.020.R | B101.020.R | | 2 | 4 | 46 | 2+1 |
| | B101.024.R | | 2,4 | 6 | 46 | 2+1 |
| A101.025.R | | | 2,5 | 8 | 48 | 2+1 |
| A101.030.R | B101.030.R | C101.030.R | 3 | 11 | 51 | 2+1 |
| | B101.032.R | | 3,2 | 11 | 51 | 2+1 |
| A101.040.R | B101.040.R | C101.040.R | 4 | 11 | 51 | 2+1 |
| | B101.048.R | | 4,8 | 11 | 51 | 2+1 |
| A101.050.R | | C101.050.R | 5 | 11 | 51 | 2+1 |
| A101.060.R | B101.060.R | C101.060.R | 6 | 19 | 51 | 2+1 |
| | B101.064.R | | 6,4 | 19 | 51 | 2+1 |
| A101.070.R | B101.070.R | C101.070.R | 7 | 19 | 51 | 2+1 |
| A101.080.R | B101.080.R | C101.080.R | 8 | 19 | 51 | 2+1 |
| | B102.048.R | | 4,8 | 16 | 55 | 2+1 |
| A102.050.R | | C102.050.R | 5 | 16 | 55 | 2+1 |
| A102.060.R | B102.060.R | C102.060.R | 6 | 25 | 57 | 2+1 |
| | B102.064.R | | 6,4 | 25 | 57 | 2+1 |
| A102.080.R | B102.080.R | C102.080.R | 8 | 25 | 57 | 2+1 |
| | | | | | | |
| A103.080.R | B103.080.R | C103.080.R | 8 | 32 | 63 | 2+1 |

HW STRAIGHT BITS

ART. A101/2/3 - B101/2/3 - C101/2/3

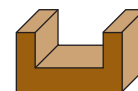
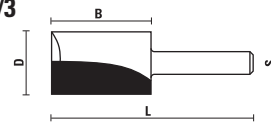

- Straight cut
- Z=2+1 also plunging



| S Ø 6 | S Ø 6,4 (1/4") | S Ø 8 | D | B | L | Z |
|------------|----------------|-----------------------|------|----|----|-----|
| A101.090.R | | C101.090.R | 9 | 19 | 51 | 2 |
| | B101.095.R | | 9,5 | 19 | 51 | 2 |
| A101.100.R | B101.100.R | C101.100.R | 10 | 19 | 51 | 2 |
| A101.101.R | | C101.101.R | 10 | 19 | 51 | 2+1 |
| A101.110.R | B101.110.R | C101.110.R | 11 | 19 | 51 | 2 |
| A101.120.R | B101.120.R | C101.120.R | 12 | 19 | 51 | 2 |
| A101.121.R | | C101.121.R | 12 | 19 | 51 | 2+1 |
| | B101.127.R | | 12,7 | 19 | 51 | 2 |
| A101.130.R | | C101.130.R | 13 | 19 | 51 | 2 |
| A101.140.R | B101.140.R | C101.140.R | 14 | 19 | 51 | 2 |
| A101.141.R | | C101.141.R | 14 | 19 | 51 | 2+1 |
| A101.150.R | B101.150.R | C101.150.R | 15 | 19 | 51 | 2 |
| A101.160.R | B101.160.R | C101.160.R | 16 | 19 | 51 | 2 |
| A101.161.R | | C101.161.R | 16 | 19 | 51 | 2+1 |
| A101.170.R | | C101.170.R | 17 | 19 | 51 | 2 |
| A101.180.R | B101.180.R | C101.180.R | 18 | 19 | 51 | 2 |
| A101.181.R | | C101.181.R | 18 | 19 | 51 | 2+1 |
| A101.190.R | B101.190.R | C101.190.R | 19 | 19 | 51 | 2 |
| | | C101.191.R NEW | 19 | 19 | 51 | 2+1 |
| A101.200.R | B101.200.R | C101.200.R | 20 | 19 | 51 | 2 |
| A101.201.R | | C101.201.R | 20 | 19 | 51 | 2+1 |
| A101.210.R | | C101.210.R | 21 | 19 | 51 | 2 |
| A101.220.R | B101.220.R | C101.220.R | 22 | 19 | 51 | 2 |
| A101.221.R | | C101.221.R | 22 | 19 | 51 | 2+1 |
| | | C101.240.R | 24 | 19 | 51 | 2 |
| A101.250.R | | C101.250.R | 25 | 19 | 51 | 2 |
| | B101.254.R | | 25,4 | 19 | 51 | 2 |
| | B102.095.R | | 9,5 | 25 | 57 | 2 |
| A102.100.R | B102.100.R | C102.100.R | 10 | 25 | 57 | 2 |
| A102.101.R | | C102.101.R | 10 | 25 | 57 | 2+1 |
| A102.120.R | B102.120.R | C102.120.R | 12 | 25 | 57 | 2 |
| A102.121.R | | C102.121.R | 12 | 25 | 57 | 2+1 |
| | B102.127.R | | 12,7 | 25 | 57 | 2 |
| | | C102.140.R | 14 | 25 | 57 | 2 |
| A102.160.R | B102.160.R | C102.160.R | 16 | 25 | 57 | 2 |
| A102.161.R | | C102.161.R | 16 | 25 | 57 | 2+1 |
| | B103.095.R | | 9,5 | 32 | 63 | 2 |
| A103.100.R | B103.100.R | C103.100.R | 10 | 32 | 63 | 2 |
| A103.120.R | B103.120.R | C103.120.R | 12 | 32 | 63 | 2 |
| | B103.127.R | | 12,7 | 32 | 63 | 2 |
| A103.150.R | | | 15 | 32 | 63 | 2 |
| A103.160.R | B103.160.R | C103.160.R | 16 | 32 | 63 | 2 |

Straight bits sets in wooden case see page 1.28 and 1.31

VHW DOUBLE FLASH TRIMMING BITS

ART. A101

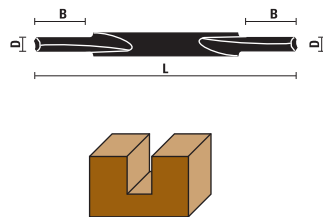

Solid carbide



| S Ø 6 | D | B | L | Z |
|------------|---|----|----|-----|
| A101.031.R | 3 | 11 | 65 | 2+1 |

HW MORTISING PILOT BITS Z=2

ART. A104 - B104 - C104

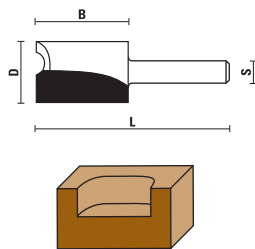

| S Ø 6 | S Ø 6,4 (1/4") | S Ø 8 | D | B | L |
|------------|----------------|------------|------|----|----|
| A104.127.R | B104.127.R | C104.127.R | 12,7 | 19 | 51 |
| A104.160.R | B104.160.R | C104.160.R | 16 | 19 | 51 |
| A104.190.R | B104.190.R | C104.190.R | 19 | 19 | 51 |

HW HINGE MORTISING BITS Z=2

ART. A104

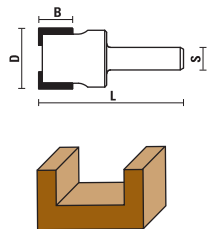

Suitable for routing lateral shallow recesses such as hinge leaves or general large shallow cuts, thanks to the shorter length. Especially made with lateral slots for better chip evacuation.



| S Ø 6 | D | B | L |
|-----------------------|----|---|----|
| A104.580.R NEW | 8 | 9 | 37 |
| A104.600.R NEW | 10 | 9 | 37 |
| A104.620.R NEW | 12 | 9 | 37 |
| A104.630.R NEW | 13 | 9 | 37 |
| A104.640.R NEW | 14 | 9 | 37 |
| A104.650.R NEW | 15 | 9 | 37 |
| A104.660.R NEW | 16 | 9 | 37 |
| A104.670.R NEW | 17 | 9 | 37 |
| A104.680.R NEW | 18 | 9 | 37 |
| A104.700.R NEW | 20 | 9 | 37 |
| A104.710.R NEW | 21 | 9 | 37 |
| A104.720.R NEW | 22 | 9 | 37 |
| A104.730.R NEW | 23 | 9 | 37 |
| A104.740.R NEW | 24 | 9 | 37 |
| A104.750.R NEW | 25 | 9 | 37 |
| A104.800.R NEW | 30 | 9 | 37 |

HW PANEL PILOT BITS Z=1+1

ART. A105 - B105 - C105

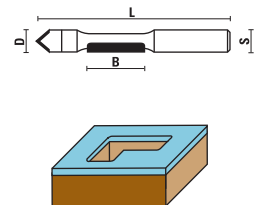

Ideal for working laminated panels



| S Ø 6 | S Ø 6,4 (1/4") | S Ø 8 | D | B | L |
|--------------|----------------|------------|-----|----|----|
| A105.060.R ▲ | | | 6 | 19 | 63 |
| A105.064.R | B105.064.R | C105.064.R | 6,4 | 19 | 63 |
| | | C105.080.R | 8 | 19 | 63 |

▲ Solid carbide

HW DOUBLE PANEL PILOT BITS

ART. A106 - C106

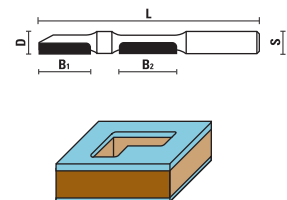

Ideal for working laminated panels top and bottom side

| S Ø 6 | S Ø 8 | D | B1 | B2 | L |
|------------|------------|---|----|----|----|
| A106.060.R | C106.060.R | 6 | 18 | 18 | 75 |

HW BEVEL TRIM BITS Z=2

ART. A107 - B107 - C107

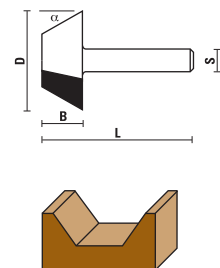

| S Ø 6 | S Ø 6,4 (1/4") | S Ø 8 | D | α | B | L |
|------------|----------------|------------|------|-----|----|----|
| A107.127.R | B107.127.R | | 12,7 | 15° | 13 | 51 |
| A107.143.R | B107.143.R | | 14,3 | 10° | 16 | 45 |
| A107.222.R | B107.222.R | C107.222.R | 22,2 | 23° | 10 | 38 |
| A107.254.R | B107.254.R | C107.254.R | 25,4 | 30° | 10 | 38 |
| A107.350.R | B107.350.R | C107.350.R | 35 | 45° | 10 | 38 |

HW BEVEL TRIM BITS Z=2

ART. A107 - B107 - C107

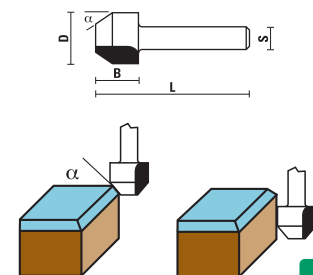

| S Ø 6 | S Ø 6,4 (1/4") | S Ø 8 | D | α | B | L |
|------------|----------------|------------|------|-----|------|----|
| A107.030.R | B107.030.R | C107.030.R | 12,7 | 30° | 12,7 | 41 |
| A107.045.R | B107.045.R | C107.045.R | 12,7 | 45° | 12,7 | 41 |

VHW DOVETAIL BITS Z=2

ART. A108

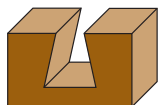
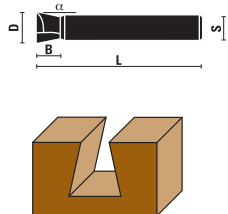

- To use for joints "Hoffmann" system.
- For frames, matchboards, drawers, window and door frames, pallets and wood products in general.



| S Ø 6 | S Ø 8 | D | α | B | L | Nr. |
|--------------|------------|------|-----|-----|----|-----|
| A108.053.R ▲ | | 5,3 | 17° | 4 | 43 | 1 |
| A108.078.R ▲ | | 7,8 | 18° | 6 | 43 | 2 |
| A108.093.R ▲ | | 9,3 | 19° | 7,5 | 43 | 3 |
| | C108.161.R | 15,8 | 20° | 13 | 43 | 4 |

▲ Solid carbide

Dowel pin nr. 1



Dowel pin nr. 2



Dowel pin nr. 3



Dowel pin nr. 4

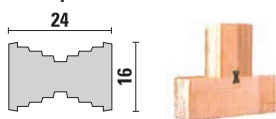

HW DOVETAIL BITS Z=2

ART. A108 - B108 - C108

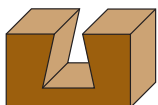
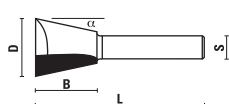

| S Ø 6 | S Ø 6,4 (1/4") | D | α | B | L |
|--------------|----------------|------|-----|------|----|
| A108.064.R ▲ | B108.064.R | 6,4 | 7° | 8 | 63 |
| A108.080.R ▲ | B108.080.R | 8 | 9° | 9,5 | 63 |
| A108.095.R | B108.095.R | 9,5 | 9° | 9,5 | 42 |
| A108.127.R | B108.127.R | 12,7 | 14° | 13 | 45 |
| A108.150.R | | 15 | 12° | 14,5 | 58 |
| A108.160.R | B108.160.R | 16 | 7° | 16 | 45 |
| A108.190.R | B108.190.R | 19 | 7° | 19 | 65 |

▲ Solid carbide

| S Ø 8 | D | α | B | L |
|------------|------|-----|------|----|
| C108.064.R | 6,4 | 7° | 8 | 44 |
| C108.080.R | 8 | 9° | 9,5 | 42 |
| C108.095.R | 9,5 | 9° | 9,5 | 47 |
| C108.127.R | 12,7 | 14° | 13 | 49 |
| C108.150.R | 15 | 12° | 14,5 | 61 |
| C108.160.R | 16 | 7° | 16 | 49 |
| C108.190.R | 19 | 14° | 19 | 55 |
| C108.191.R | 19 | 7° | 19 | 60 |

Dovetail bits sets in wooden case see page 1.29 and 1.33

HW DOVETAIL BITS Z=2

ART. A108 - B108 - C108

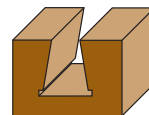
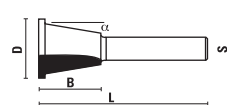

| S Ø 6 | S Ø 6,4 (1/4") | S Ø 8 | D | α | B | L |
|------------|----------------|------------|------|-----|------|----|
| A108.143.R | B108.143.R | C108.143.R | 14,3 | 13° | 13,5 | 55 |

HW V-GROOVE AND SIGNMAKING BITS

ART. A109 - B109 - C109
A110 - B110 - C110

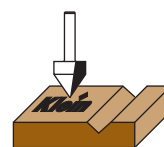
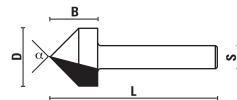

- Suitable for engravings and sign writing

| S Ø 6 | S Ø 6,4 (1/4") | S Ø 8 | D | α | B | L | Z |
|--------------|----------------|--------------|------|-----|----|----|---|
| A109.060.R ▲ | | C109.060.R | 6 | 90° | 8 | 45 | 2 |
| A109.095.R | B109.095.R | C109.095.R | 9,5 | 90° | 11 | 45 | 2 |
| A109.127.R | B109.127.R | C109.127.R | 12,7 | 90° | 13 | 45 | 2 |
| A109.160.R | B109.160.R | C109.160.R | 16 | 90° | 13 | 45 | 2 |
| A109.190.R | | C109.190.R | 19 | 90° | 16 | 45 | 2 |
| A109.254.R | B109.254.R | C109.254.R | 25,4 | 90° | 19 | 48 | 2 |
| | | ① C109.380.R | 38 | 90° | 20 | 63 | 2 |

| | | | | | | | |
|------------|------------|--------------|------|-----|----|----|---|
| A110.127.R | B110.127.R | C110.127.R | 12,7 | 60° | 16 | 45 | 2 |
| A110.140.R | B110.140.R | C110.140.R | 14 | 60° | 22 | 57 | 3 |
| | | ② C110.190.R | 19 | 45° | 25 | 63 | 2 |

▲ Solid carbide

① - ② Items for working plasterboard panels

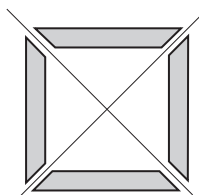

① Bit makes a 45° chamfer that can be used to build square share

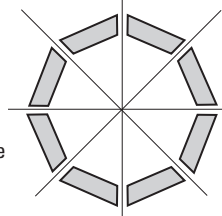

② Bit makes a 22,5° chamfer that can be used to build a B-side box (to an octagonal)

VHW U-GROOVE AND SIGNMAKING BITS

ART. A111

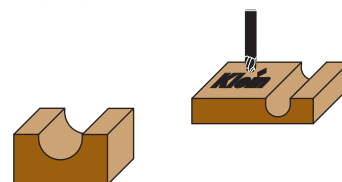

- Solid carbide
- Suitable for engravings and sign writing

| S Ø 6 | D | R | B | L | Z |
|------------|---|---|---|----|---|
| A111.060.R | 6 | 3 | 9 | 60 | 3 |

HW CORE BOX BITS Z=2

ART. A111 - B111 - C111

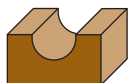
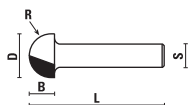

| S Ø 6 | S Ø 6,4 (1/4") | S Ø 8 | D | R | B | L |
|--------------|----------------|-----------------------|------|------|----|----|
| A111.032.R ▲ | B111.032.R | C111.032.R | 3,2 | 1,6 | 10 | 44 |
| A111.048.R ▲ | B111.048.R | C111.048.R | 4,8 | 2,4 | 13 | 44 |
| A111.064.R ▲ | B111.064.R | C111.064.R | 6,4 | 3,2 | 13 | 44 |
| A111.080.R ▲ | B111.080.R | C111.080.R | 8 | 4 | 13 | 47 |
| A111.095.R | B111.095.R | C111.095.R | 9,5 | 4,8 | 7 | 38 |
| A111.127.R | B111.127.R | C111.127.R | 12,7 | 6,4 | 10 | 38 |
| A111.160.R | B111.160.R | C111.160.R | 16 | 8 | 11 | 40 |
| A111.180.R | B111.180.R | C111.180.R | 18 | 9 | 19 | 47 |
| | | C111.190.R | 19 | 9,5 | 11 | 47 |
| | | C111.200.R NEW | 20 | 10 | 19 | 47 |
| | | C111.220.R | 22 | 11 | 14 | 45 |
| | | C111.254.R | 25,4 | 12,7 | 17 | 47 |

▲ Solid carbide

HW PLUNGING ROUND-OVER BITS Z=2

ART. A112 - B112 - C112

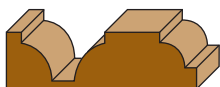
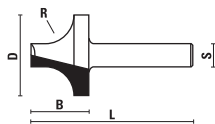

| S Ø 6 | S Ø 6,4 (1/4") | S Ø 8 | D | R | B | L |
|------------|----------------|------------|------|------|------|----|
| A112.140.R | | C112.140.R | 14 | 4 | 13 | 41 |
| A112.160.R | | C112.160.R | 16 | 5 | 13 | 41 |
| A112.180.R | | C112.180.R | 18 | 6 | 13 | 41 |
| A112.190.R | B112.190.R | C112.190.R | 19 | 6,4 | 13 | 41 |
| A112.220.R | B112.220.R* | C112.220.R | 22 | 8 | 14,5 | 43 |
| A112.254.R | B112.254.R | C112.254.R | 25,4 | 9,5 | 16 | 44 |
| | | C112.350.R | 35 | 12,7 | 25,4 | 63 |

* Selling out

HW PLUNGING ROUND-OVER BITS Z=2

ART. C112

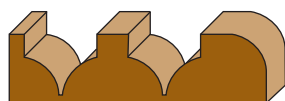

| S Ø 8 | D | R | B | L |
|------------|----|---|----|----|
| C112.030.R | 8 | 3 | 10 | 50 |
| C112.040.R | 10 | 4 | 10 | 50 |
| C112.050.R | 12 | 5 | 10 | 50 |

HW PLUNGE TYPE OGEE BITS Z=2

ART. A113 - B113 - C113

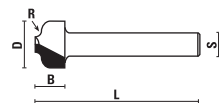

| S Ø 6 | S Ø 6,4 (1/4") | S Ø 8 | D | R | B | L |
|------------|----------------|------------|------|-----|----|----|
| A113.095.R | | C113.095.R | 9,5 | 1,6 | 8 | 51 |
| A113.127.R | B113.127.R | C113.127.R | 12,7 | 2 | 10 | 51 |
| A113.190.R | B113.190.R | C113.190.R | 19 | 3,5 | 13 | 54 |

HW PLUNGE TYPE TRADITIONAL BITS Z=2

ART. A114 - B114 - C114

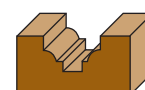
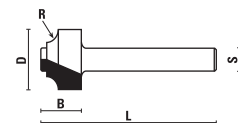

| S Ø 6 | S Ø 8 | D | R | B | L |
|------------|------------|------|-----|----|----|
| A114.127.R | C114.127.R | 12,7 | 2 | 10 | 51 |
| A114.190.R | C114.190.R | 19 | 3,5 | 11 | 52 |

HW PLUNGE TYPE CLASSICAL BITS Z=2

ART. A115 - B115 - C115

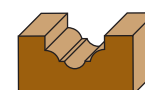
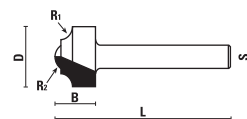

| S Ø 6 | S Ø 6,4 (1/4") | S Ø 8 | D | R1 | R2 | B | L |
|------------|----------------|------------|------|-----|-----|------|----|
| A115.127.R | B115.127.R | C115.127.R | 12,7 | 2,5 | 3,5 | 10 | 51 |
| A115.190.R | B115.190.R | C115.190.R | 19 | 3,7 | 4 | 13 | 54 |
| | | C115.254.R | 25,4 | 5 | 6,4 | 17,5 | 73 |

HW BULL NOSE RADIUS BITS Z=2

ART. A116 - B116 - C116

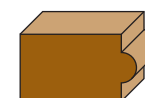
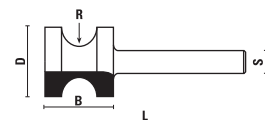

| S Ø 6 | S Ø 6,4 (1/4") | S Ø 8 | D | R | B | L |
|-------------|----------------|------------|------|-----|----|----|
| A116.135.R | B116.135.R | C116.135.R | 13,5 | 2 | 13 | 41 |
| A116.150.R | B116.150.R | C116.150.R | 15 | 2,8 | 13 | 42 |
| A116.167.R | B116.167.R | C116.167.R | 16,7 | 3,6 | 19 | 48 |
| A116.222.R | B116.222.R | C116.222.R | 22,2 | 5,2 | 19 | 48 |
| A116.260.R* | | C116.260.R | 26 | 6,8 | 25 | 54 |

* Selling out

SLOT CUTTER ARBORS

ART. A117 - B117 - C117 - E117 - G117

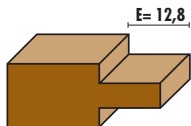
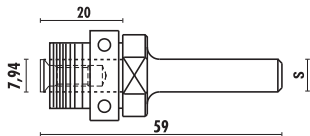

| S Ø 6 | S Ø 6,4 (1/4") | S Ø 8 | S Ø 12 | S Ø 12,7 (1/2") |
|------------|----------------|------------|------------|-----------------|
| A117.280.R | B117.280.R | C117.280.R | E117.280.R | G117.280.R |

With ball bearing



Z050.008.N



Z051.015.R



nr. 2 - Z057.002.N - 1 mm
nr. 2 - Z057.003.N - 0,5 mm
nr. 5 - Z057.004.N - 0,1 mm
nr. 2 - Z057.005.N - 3 mm

Change the ball bearing to get different cutting depths (see page 10.05)

| A117.281.R | B117.281.R | C117.281.R | E117.281.R | G117.281.R |
|----------------------|------------|------------|------------|------------|
| Without ball bearing | | | | |



Z051.015.R



nr. 3 - Z057.002.N - 1 mm
nr. 2 - Z057.003.N - 0,5 mm
nr. 6 - Z057.004.N - 0,1 mm
nr. 2 - Z057.005.N - 3 mm
nr. 1 - Z057.006.N - 6 mm

HW SLOT CUTTERS SPECIAL FIXING SCREW Z=3

ART. C118

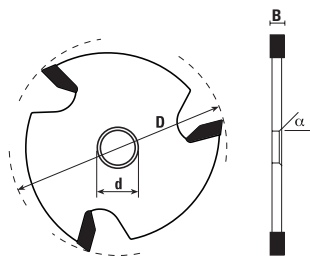

- To be used with slot cutter arbors
- $\alpha = 45^\circ$ bore



| Item | d | D | B | Z |
|------------|------|------|-----|---|
| C118.830.R | 7,94 | 47,6 | 3 | 3 |
| C118.832.R | 7,94 | 47,6 | 3,2 | 3 |
| C118.840.R | 7,94 | 47,6 | 4 | 3 |
| C118.848.R | 7,94 | 47,6 | 4,8 | 3 |
| C118.850.R | 7,94 | 47,6 | 5 | 3 |
| C118.860.R | 7,94 | 47,6 | 6 | 3 |
| C118.864.R | 7,94 | 47,6 | 6,4 | 3 |

Example of processing:
The fixing screw (Art. Z051.015.R) used on this spindle has a special head angle that allows it to remain flat on the cutter level.

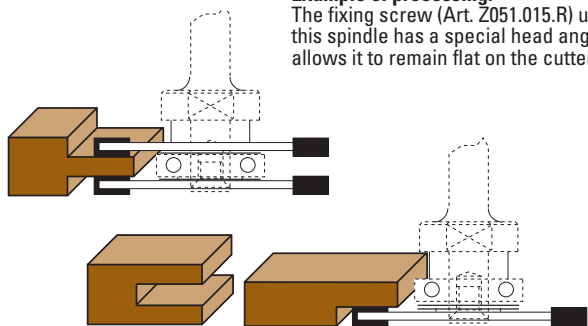

SLOT CUTTER ARBORS

ART. A117 - B117 - C117 - E117 - G117

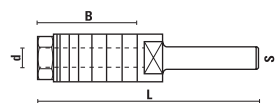

Used with cutters Art. A118 - C118, spacers Art. Z057 and ball bearing Art. Z050 (see section 10)



| S Ø 6 | S Ø 6,4 (1/4") | S Ø 8 | d | B | L |
|------------|----------------|------------|------|----|-----|
| A117.060.R | B117.060.R | | 6 | 17 | 52 |
| A117.080.R | B117.080.R | | 7,94 | 34 | 67 |
| | | C117.060.R | 6 | 17 | 57 |
| | | C117.079.R | 7,94 | 34 | 70 |
| | | C117.080.N | 7,94 | 53 | 96 |
| | | C117.081.N | 7,94 | 66 | 108 |
| | | C117.082.N | 7,94 | 38 | 80 |

| S Ø 12 | S Ø 12,7 (1/2") | d | B | L |
|------------|-----------------|------|----|-----|
| E117.120.N | G117.120.R | 7,94 | 53 | 96 |
| E117.121.N | G117.121.R | 7,94 | 66 | 108 |
| E117.122.N | G117.122.R | 7,94 | 38 | 80 |
| E117.123.N | G117.123.R | 7,94 | 34 | 76 |

HW SLOT CUTTERS Z=2

ART. A118

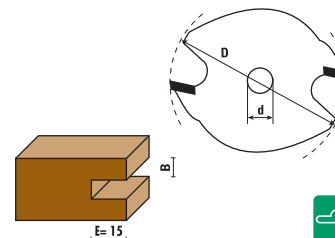

| Bore Ø 6 | d | D | B | Z |
|------------|---|----|-----|---|
| A118.015.R | 6 | 40 | 1,5 | 2 |
| A118.018.R | 6 | 40 | 1,8 | 2 |
| A118.020.R | 6 | 40 | 2 | 2 |
| A118.025.R | 6 | 40 | 2,5 | 2 |
| A118.030.R | 6 | 40 | 3 | 2 |
| A118.035.R | 6 | 40 | 3,5 | 2 |
| A118.040.R | 6 | 40 | 4 | 2 |
| A118.050.R | 6 | 40 | 5 | 2 |
| A118.060.R | 6 | 40 | 6 | 2 |

HW SLOT CUTTERS Z=2

ART. C118

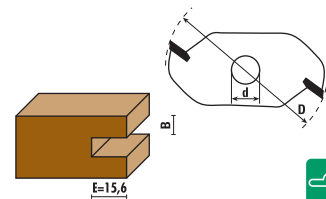

| Item | d | D | B | Z |
|------------|------|------|-----|---|
| C118.216.R | 7,94 | 47,6 | 1,6 | 2 |
| C118.220.R | 7,94 | 47,6 | 2 | 2 |
| C118.224.R | 7,94 | 47,6 | 2,4 | 2 |
| C118.230.R | 7,94 | 47,6 | 3 | 2 |
| C118.232.R | 7,94 | 47,6 | 3,2 | 2 |
| C118.240.R | 7,94 | 47,6 | 4 | 2 |
| C118.248.R | 7,94 | 47,6 | 4,8 | 2 |
| C118.250.R | 7,94 | 47,6 | 5 | 2 |
| C118.260.R | 7,94 | 47,6 | 6 | 2 |
| C118.264.R | 7,94 | 47,6 | 6,4 | 2 |

HW SLOT CUTTERS Z=3

ART. C118

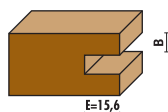
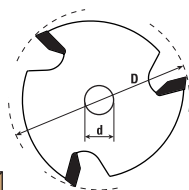

| Item | d | D | B | Z |
|------------|------|------|-----|---|
| C118.316.R | 7,94 | 47,6 | 1,6 | 3 |
| C118.320.R | 7,94 | 47,6 | 2 | 3 |
| C118.324.R | 7,94 | 47,6 | 2,4 | 3 |
| C118.330.R | 7,94 | 47,6 | 3 | 3 |
| C118.332.R | 7,94 | 47,6 | 3,2 | 3 |
| C118.340.R | 7,94 | 47,6 | 4 | 3 |
| C118.348.R | 7,94 | 47,6 | 4,8 | 3 |
| C118.350.R | 7,94 | 47,6 | 5 | 3 |
| C118.360.R | 7,94 | 47,6 | 6 | 3 |
| C118.364.R | 7,94 | 47,6 | 6,4 | 3 |



To be used with **SLOT CUTTER ARBORS**
ART. A117 - B117 - C117 - E117 - G117

HW TRIMMING BITS WITH BALL BEARING Z=2

ART. A119 - B119 - C119

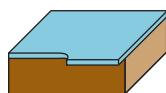
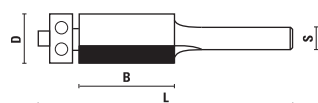

Ideal for working laminated panels

| S Ø 6 | S Ø 6,4 (1/4") | D | B | L | |
|------------|----------------|------------|------------|----|----|
| A119.064.R | B119.064.R | 6,4 | 13 | 53 | |
| | | | | | |
| Z050.017.N | Z051.006.N | | | | |
| S Ø 6 | S Ø 6,4 (1/4") | S Ø 8 | D | B | L |
| A119.095.R | B119.095.R | C119.095.R | 9,5 | 13 | 54 |
| | | | | | |
| Z050.002.N | Z053.002.N | Z054.002.N | Z051.002.R | | |
| S Ø 6 | S Ø 6,4 (1/4") | S Ø 8 | D | B | L |
| A119.127.R | B119.127.R | C119.127.R | 12,7 | 13 | 60 |
| | | | | | |
| Z050.003.N | Z053.002.N | Z054.002.N | Z051.002.R | | |

HW TRIMMING BITS WITH BALL BEARING Z=2

ART. A119 - B119 - C119

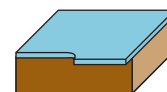
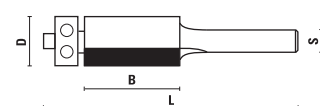

- Ideal for working laminated panels
- **Shear angle cutting edge**

| S Ø 6 | S Ø 6,4 (1/4") | S Ø 8 | D | B | L |
|------------|----------------|------------|------------|----|----|
| A119.160.R | B119.160.R | C119.160.R | 16 | 16 | 56 |
| | | | | | |
| Z050.004.N | Z053.004.N | Z054.002.N | Z051.002.R | | |

| S Ø 6 | S Ø 6,4 (1/4") | S Ø 8 | D | B | L |
|------------|----------------|------------|----|----|----|
| A119.190.R | B119.190.R | C119.190.R | 19 | 16 | 60 |
| A119.191.R | B119.191.R | C119.191.R | 19 | 25 | 72 |

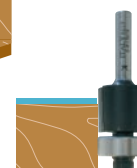
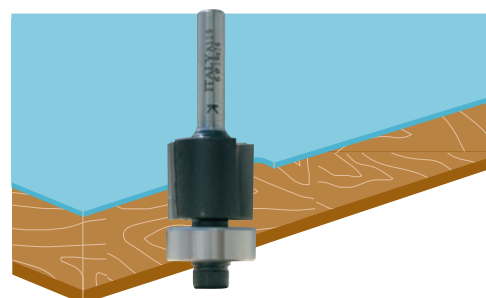

HW TRIMMING BITS WITH BALL BEARING Z=2

ART. A120 - B120 - C120

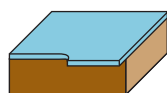
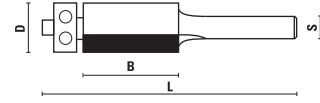

Ideal for working laminated panels

| S Ø 6 | S Ø 6,4 (1/4") | D | B | L | |
|------------|----------------|------------|------------|----|----|
| A120.064.R | B120.064.R | 6,4 | 25 | 67 | |
| | | | | | |
| Z050.017.N | Z051.006.N | | | | |
| S Ø 6 | S Ø 6,4 (1/4") | S Ø 8 | D | B | L |
| A120.095.R | B120.095.R | C120.095.R | 9,5 | 25 | 67 |
| | | | | | |
| Z050.002.N | Z053.002.N | Z054.002.N | Z051.002.R | | |
| S Ø 6 | S Ø 6,4 (1/4") | S Ø 8 | D | B | L |
| A120.127.R | B120.127.R | C120.127.R | 12,7 | 25 | 67 |
| | | | | | |
| Z050.003.N | Z053.003.N | Z054.002.N | Z051.002.R | | |

HW RABBETING BITS WITH BALL BEARING Z=2

ART. A121 - B121 - C121

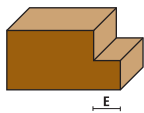
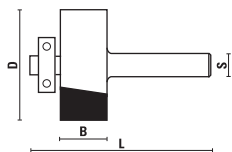

| S Ø 6 | S Ø 6,4 (1/4") | S Ø 8 | D | B | E | L |
|------------|----------------|------------|----|----|---|----|
| A121.240.R | B121.240.R | C121.240.R | 24 | 13 | 4 | 54 |



Z050.011.N



Z054.003.N



Z051.004.N

| S Ø 6 | S Ø 6,4 (1/4") | S Ø 8 | D | B | E | L |
|------------|----------------|------------|------|----|-----|----|
| A121.317.R | B121.317.R | C121.317.R | 31,7 | 13 | 9,5 | 51 |
| A121.350.R | B121.350.R | C121.350.R | 35 | 13 | 11 | 51 |



Z050.003.N



Z053.003.N



Z054.002.N



Z051.002.R

HW RABBETING BITS WITH BALL BEARING Z=2

ART. A121 - B121 - C121

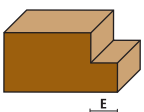
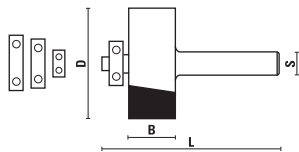

Supplied with nr. 4 ball bearings in order to obtain E= 8 - 9,5 - 11 - 12,7

| S Ø 6 | S Ø 6,4 (1/4") | S Ø 8 | D | B | E | L |
|------------|----------------|------------|----|----|---------------|----|
| A121.850.R | B121.850.R | C121.850.R | 35 | 13 | 8/9,5/11/12,7 | 51 |



E=8 Z050.023.N



E=9,5 Z050.022.N



E=11 Z050.003.N



E=12,7 Z050.002.N



Z051.002.R

HW BEVEL TRIM BITS WITH BALL BEARING Z=2

ART. A122 - B122

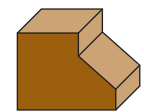
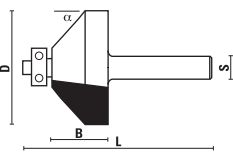

| S Ø 6 | S Ø 6,4 (1/4") | D | α | B | L |
|------------|----------------|----|-----|----|----|
| A122.350.R | B122.350.R | 35 | 45° | 18 | 57 |



Z050.003.N



Z053.003.N



Z054.002.N



Z051.002.R

HW BEVEL TRIM BITS WITH BALL BEARING GUIDE

ART. A122 - B122 - C122

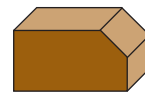
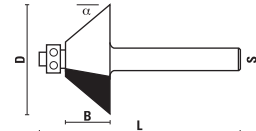

| S Ø 6 | S Ø 6,4 (1/4") | S Ø 8 | D | α | B | L | Z |
|------------|----------------|------------|------|-----|----|----|---|
| A122.010.R | B122.010.R | C122.010.R | 17,5 | 10° | 10 | 49 | 3 |
| A122.015.R | B122.015.R | C122.015.R | 19 | 15° | 10 | 49 | 3 |
| A122.025.R | B122.025.R | C122.025.R | 22 | 25° | 10 | 49 | 3 |
| A122.045.R | B122.045.R | C122.045.R | 30 | 45° | 10 | 49 | 3 |



Z050.004.N



Z053.004.N



Z054.002.N



Z051.002.R

| S Ø 6 | S Ø 6,4 (1/4") | S Ø 8 | D | α | B | L | Z |
|------------|----------------|------------|------|-----|------|----|---|
| A122.130.R | B122.130.R | C122.130.R | 13 | 15° | 12,7 | 46 | 2 |
| A122.190.R | B122.190.R | C122.190.R | 19 | 25° | 12,7 | 46 | 2 |
| A122.317.R | B122.317.R | C122.317.R | 31,7 | 45° | 13 | 51 | 2 |



Z050.001.N



Z053.001.N



Z054.001.N



Z051.001.R

HW CORNER ROUNDING BITS WITH BALL BEARING Z=2

ART. A123 - B123 - C123

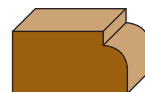
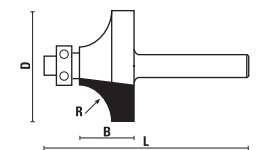

| S Ø 6 | S Ø 6,4 (1/4") | S Ø 8 | D | R | B | L |
|------------|----------------|------------|------|------|-----|----|
| A123.160.R | B123.160.R | C123.160.R | 16 | 1,6 | 8 | 46 |
| A123.167.R | | C123.167.R | 16,7 | 2 | 8 | 47 |
| A123.187.R | | C123.187.R | 18,7 | 3 | 9,5 | 49 |
| A123.190.R | B123.190.R | C123.190.R | 19 | 3,2 | 10 | 48 |
| A123.207.R | B123.207.R | C123.207.R | 20,7 | 4 | 10 | 49 |
| A123.222.R | B123.222.R | C123.222.R | 22,2 | 4,8 | 13 | 51 |
| A123.227.R | | C123.227.R | 22,7 | 5 | 12 | 51 |
| A123.247.R | | C123.247.R | 24,7 | 6 | 12 | 51 |
| A123.254.R | B123.254.R | C123.254.R | 25,4 | 6,4 | 13 | 51 |
| A123.286.R | B123.286.R | C123.286.R | 28,6 | 8 | 13 | 51 |
| A123.318.R | B123.318.R | C123.318.R | 31,8 | 9,5 | 16 | 56 |
| A123.327.R | | C123.327.R | 32,7 | 10 | 16 | 55 |
| A123.354.R | B123.354.R | C123.354.R | 35,4 | 11 | 17 | 57 |
| A123.367.R | | C123.367.R | 36,7 | 12 | 20 | 57 |
| A123.380.R | B123.380.R | C123.380.R | 38 | 12,7 | 19 | 57 |



Z050.003.N



Z053.003.N



Z054.002.N



Z051.002.R

Corner rounding bits sets in wooden case see page 1.34

HW BEADING BITS WITH BALL BEARING GUIDE Z=2

ART. A124 - B124 - C124

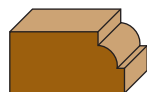
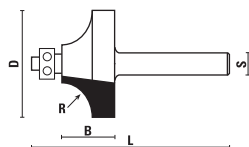

| S Ø 6 | S Ø 6,4 (1/4") | S Ø 8 | D | R | B | L |
|------------|----------------|------------|------|------|-----|----|
| A124.160.R | B124.160.R | C124.160.R | 16 | 1,6 | 8 | 46 |
| A124.167.R | | C124.167.R | 16,7 | 2 | 8 | 47 |
| A124.187.R | | C124.187.R | 18,7 | 3 | 9,5 | 49 |
| A124.190.R | B124.190.R | C124.190.R | 19 | 3,2 | 10 | 48 |
| A124.207.R | B124.207.R | C124.207.R | 20,7 | 4 | 10 | 49 |
| A124.222.R | B124.222.R | C124.222.R | 22,2 | 4,8 | 13 | 51 |
| A124.227.R | | C124.227.R | 22,7 | 5 | 12 | 51 |
| A124.247.R | | C124.247.R | 24,7 | 6 | 12 | 51 |
| A124.254.R | B124.254.R | C124.254.R | 25,4 | 6,4 | 13 | 51 |
| A124.286.R | B124.286.R | C124.286.R | 28,6 | 8 | 13 | 51 |
| A124.318.R | B124.318.R | C124.318.R | 31,8 | 9,5 | 16 | 56 |
| A124.327.R | | C124.327.R | 32,7 | 10 | 16 | 55 |
| A124.367.R | | C124.367.R | 36,7 | 12 | 20 | 57 |
| A124.380.R | B124.380.R | C124.380.R | 38 | 12,7 | 19 | 57 |



Z050.002.N



Z053.002.N



Z054.002.N



Z051.002.R

HW COVE BITS WITH BALL BEARING GUIDE Z=2

ART. A125 - B125 - C125

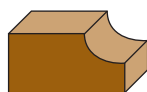
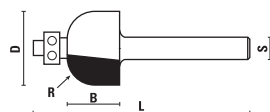

| S Ø 6 | S Ø 6,4 (1/4") | S Ø 8 | D | R | B | L |
|------------|----------------|------------|------|------|----|----|
| A125.160.R | B125.160.R | C125.160.R | 16 | 3,2 | 13 | 51 |
| A125.190.R | B125.190.R | C125.190.R | 19 | 4,8 | 14 | 51 |
| A125.222.R | B125.222.R | C125.222.R | 22,2 | 6,4 | 14 | 51 |
| A125.254.R | B125.254.R | C125.254.R | 25,4 | 8 | 14 | 51 |
| A125.286.R | B125.286.R | C125.286.R | 28,6 | 9,5 | 14 | 51 |
| A125.350.R | B125.350.R | C125.350.R | 35 | 12,7 | 16 | 54 |



Z050.001.N



Z053.001.N



Z054.001.N



Z051.001.R

HW DOUBLE FILLET COVE BITS WITH BALL BEARING GUIDE Z=2

ART. A126 - B126 - C126

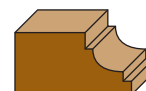
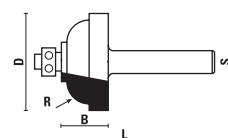

| S Ø 6 | S Ø 6,4 (1/4") | S Ø 8 | D | R | B | L |
|------------|----------------|------------|------|-----|----|----|
| A126.286.R | B126.286.R | C126.286.R | 28,6 | 4,8 | 13 | 51 |
| A126.350.R | B126.350.R | C126.350.R | 35 | 8 | 16 | 54 |



Z050.003.N



Z053.003.N



Z054.002.N



Z051.002.R

HW ROMAN OGEE BITS WITH BALL BEARING GUIDE Z=2

ART. A127 - B127 - C127

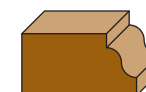
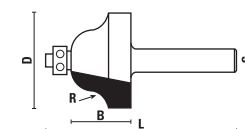

| S Ø 6 | S Ø 6,4 (1/4") | S Ø 8 | D | R | B | L |
|------------|----------------|------------|------|-----|----|----|
| A127.254.R | B127.254.R | C127.254.R | 25,4 | 4 | 16 | 54 |
| A127.350.R | B127.350.R | C127.350.R | 35 | 6,4 | 20 | 57 |



Z050.001.N



Z053.001.N



Z054.001.N



Z051.001.R

HW DOUBLE ROMAN OGEE BITS Z=2

ART. A128 - B128 - C128

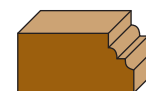
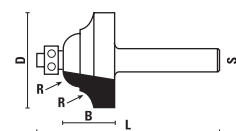

| S Ø 6 | S Ø 6,4 (1/4") | S Ø 8 | D | R | B | L |
|------------|----------------|------------|------|-----|----|----|
| A128.254.R | B128.254.R | C128.254.R | 25,4 | 4 | 16 | 53 |
| A128.350.R | B128.350.R | C128.350.R | 35 | 6,4 | 20 | 57 |



Z050.001.N



Z053.001.N



Z054.001.N



Z051.001.R

HW OGEE BITS WITH BALL BEARING GUIDE Z=2

ART. A129 - B129 - C129

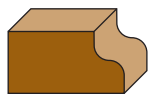
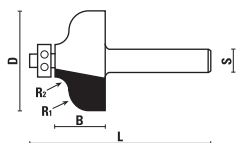

| S Ø 6 | S Ø 6,4 (1/4") | S Ø 8 | D | R1 | R2 | B | L |
|------------|----------------|------------|------|-----|----|----|----|
| A129.286.R | B129.286.R | C129.286.R | 28,6 | 4,5 | 4 | 13 | 51 |
| A129.350.R | B129.350.R | C129.350.R | 35 | 6 | 5 | 18 | 55 |



Z050.003.N



Z053.003.N



Z054.002.N



Z051.002.R

HW OGEE BITS WITH BALL BEARING GUIDE Z=2

ART. A132 - B132 - C132

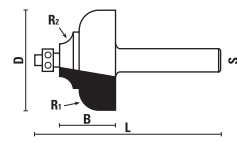

| S Ø 6 | S Ø 6,4 (1/4") | S Ø 8 | D | R1 | R2 | B | L |
|------------|----------------|------------|------|-----|-----|----|----|
| A132.286.R | B132.286.R | C132.286.R | 28,6 | 4 | 4 | 13 | 51 |
| A132.350.R | B132.350.R | C132.350.R | 35 | 6,4 | 4,8 | 18 | 56 |



Z050.002.N



Z053.002.N



Z054.002.N



Z051.002.R

HW OGEE BITS WITH BALL BEARING GUIDE Z=2

ART. A130 - B130 - C130

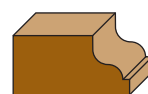
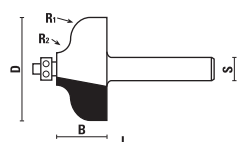

| S Ø 6 | S Ø 6,4 (1/4") | S Ø 8 | D | R1 | R2 | B | L |
|------------|----------------|------------|------|-----|----|----|----|
| A130.286.R | B130.286.R | C130.286.R | 28,6 | 4,5 | 4 | 13 | 51 |
| A130.350.R | B130.350.R | C130.350.R | 35 | 6 | 5 | 18 | 55 |



Z050.002.N



Z053.002.N



Z054.002.N



Z051.002.R

HW OGEE BITS WITH BALL BEARING GUIDE Z=2

ART. A133 - B133 - C133

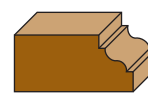
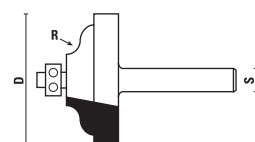

| S Ø 6 | S Ø 6,4 (1/4") | S Ø 8 | D | R | B | L |
|------------|----------------|------------|----|---|----|----|
| A133.350.R | B133.350.R | C133.350.R | 35 | 4 | 14 | 52 |



Z050.002.N



Z053.002.N



Z054.002.N



Z051.002.R

HW OGEE BITS WITH BALL BEARING GUIDE Z=2

ART. A131 - B131 - C131

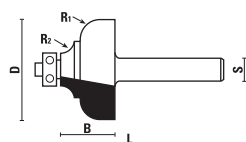

| S Ø 6 | S Ø 6,4 (1/4") | S Ø 8 | D | R1 | R2 | B | L |
|------------|----------------|------------|------|-----|-----|----|----|
| A131.286.R | B131.286.R | C131.286.R | 28,6 | 4 | 4 | 13 | 51 |
| A131.350.R | B131.350.R | C131.350.R | 35 | 6,4 | 4,8 | 18 | 56 |



Z050.003.N



Z053.003.N



Z054.002.N



Z051.002.R

HW OGEE BITS WITH BALL BEARING GUIDE Z=2

ART. A134 - B134 - C134

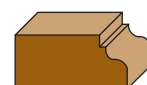
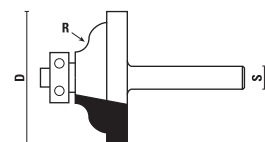

| S Ø 6 | S Ø 6,4 (1/4") | S Ø 8 | D | R | B | L |
|------------|----------------|------------|----|---|----|----|
| A134.350.R | B134.350.R | C134.350.R | 35 | 4 | 14 | 52 |



Z050.003.N



Z053.003.N



Z054.002.N



Z051.002.R

HW CLASSICAL MOULDING BITS WITH BALL BEARING GUIDE Z=2

ART. A135 - B135 - C135

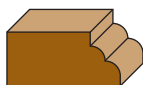
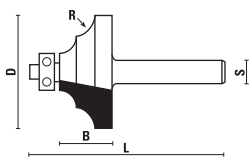

| S Ø 6 | S Ø 6,4 (1/4") | S Ø 8 | D | R | B | L |
|------------|----------------|------------|------|-----|----|----|
| A135.286.R | B135.286.R | C135.286.R | 28,6 | 4 | 13 | 51 |
| A135.350.R | B135.350.R | C135.350.R | 35 | 5,5 | 18 | 60 |



Z050.003.N



Z053.003.N



Z054.002.N



Z051.002.R

HW CLASSICAL MOULDING BITS WITH BALL BEARING GUIDE Z=2

ART. A136 - B136 - C136

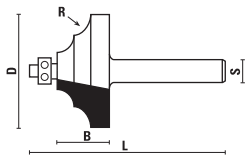

| S Ø 6 | S Ø 6,4 (1/4") | S Ø 8 | D | R | B | L |
|------------|----------------|------------|------|-----|----|----|
| A136.286.R | B136.286.R | C136.286.R | 28,6 | 4 | 13 | 51 |
| A136.350.R | B136.350.R | C136.350.R | 35 | 5,5 | 18 | 60 |



Z050.002.N



Z053.002.N



Z054.002.N



Z051.002.R

HW CORNER BEADING BITS WITH BALL BEARING GUIDE Z=2

ART. A137 - B137 - C137

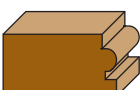
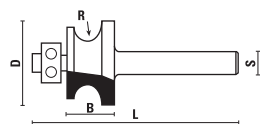

| S Ø 6 | S Ø 6,4 (1/4") | S Ø 8 | D | R | B | L |
|------------|----------------|------------|----|-----|----|----|
| A137.220.R | B137.220.R | C137.220.R | 22 | 3,2 | 14 | 54 |



Z050.003.N



Z053.003.N



Z054.002.N



Z051.002.R

| S Ø 6 | S Ø 6,4 (1/4") | S Ø 8 | D | R | B | L |
|------------|----------------|------------|----|-----|----|----|
| A137.280.R | B137.280.R | C137.280.R | 28 | 4,8 | 16 | 57 |
| A137.320.R | B137.320.R | C137.320.R | 32 | 6,4 | 19 | 58 |



Z050.004.N



Z053.004.N



Z054.002.N



Z051.002.R

HW EDGE-FLUTING BITS WITH BALL BEARING GUIDE Z=2

ART. A138 - B138

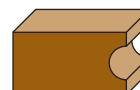
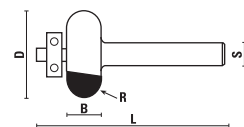

| S Ø 6 | S Ø 6,4 (1/4") | D | R | B | L |
|------------|----------------|----|---|----|----|
| A138.210.R | B138.210.R | 21 | 4 | 8 | 47 |
| A138.230.R | B138.230.R | 23 | 5 | 10 | 49 |
| A138.250.R | B138.250.R | 25 | 6 | 12 | 51 |



Z050.003.N



Z053.003.N



Z054.002.N



Z051.002.R

HW MULTI-BEADING BITS WITH BALL BEARING GUIDE Z=2

ART. A139 - B139

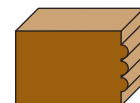
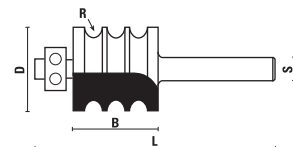

| S Ø 6 | S Ø 6,4 (1/4") | D | R | B | L |
|-------------|----------------|----|---|----|----|
| A139.220.R* | B139.220.R* | 22 | 3 | 25 | 65 |

* Selling out



Z050.004.N



Z053.004.N



Z054.002.N



Z051.002.R

HW MULTI-BEADING BITS WITH BALL BEARING GUIDE Z=2

ART. A140

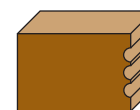
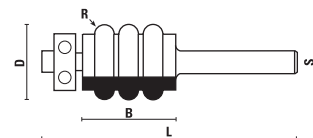

| S Ø 6 | D | R | B | L |
|-------------|----|---|----|----|
| A140.220.R* | 22 | 3 | 25 | 64 |

* Selling out



Z050.004.N



Z053.004.N



Z054.002.N



Z051.002.R

HW FLUSH-TRIM "V" GROOVE BITS WITH BALL BEARING GUIDE Z=2

ART. A141 - B141

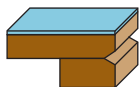
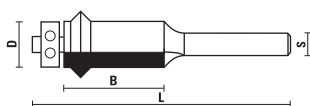

- Ideal for working laminated and melamine panels
- V-decor along the joints of the two wood pieces



| S Ø 6 | S Ø 6,4 (1/4") | D | B | L |
|------------|----------------|------|------|----|
| A141.127.R | B141.127.R | 12,7 | 25,4 | 67 |



Z050.003.N



Z053.003.N



Z054.002.N



Z051.002.R

HW FLAT ROUNDING OVER BITS WITH BALL BEARING GUIDE Z=2

ART. A142 - B142

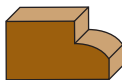
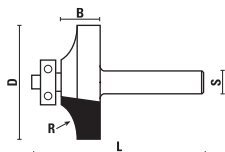

| S Ø 6 | S Ø 6,4 (1/4") | D | R | B | L |
|------------|----------------|----|----|----|----|
| A142.300.R | B142.300.R | 30 | 12 | 10 | 48 |



Z050.003.N



Z053.003.N



Z054.002.N



Z051.002.R

HW FLAT ROUNDING OVER BITS WITH BALL BEARING GUIDE Z=2

ART. A143 - B143

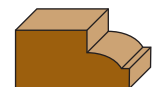
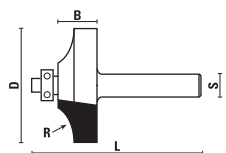

| S Ø 6 | S Ø 6,4 (1/4") | D | R | B | L |
|------------|----------------|----|----|----|----|
| A143.300.R | B143.300.R | 30 | 12 | 10 | 48 |



Z050.002.N



Z053.002.N



Z054.002.N



Z051.002.R

HW PROFILE BITS WITH BALL BEARING GUIDE

ART. A144 - B144

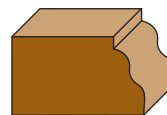
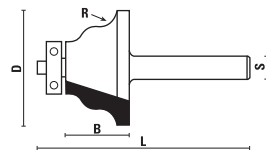

| S Ø 6 | S Ø 6,4 (1/4") | D | R | B | L |
|------------|----------------|------|---|------|----|
| A144.318.R | B144.318.R | 31,8 | 4 | 17,5 | 57 |



Z050.003.N



Z053.003.N



Z054.002.N



Z051.002.R

HW FLAT OGEE BITS WITH BALL BEARING GUIDE Z=2

ART. A145 - C145

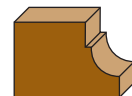
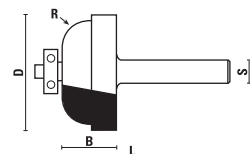

| S Ø 6 | S Ø 8 | D | R | B | L |
|-------------|------------|------|-----|----|----|
| A145.286.R* | C145.286.R | 28,6 | 4,8 | 13 | 51 |
| A145.350.R* | C145.350.R | 35 | 8 | 16 | 55 |

* Selling out



Z050.003.N



Z053.003.N



Z054.002.N



Z051.002.R

HW OVOLO JOINT BITS WITH BALL BEARING GUIDE Z=2

ART. A146 - C146

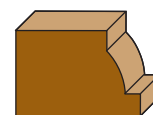
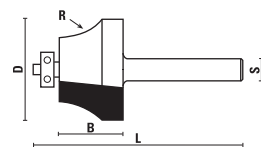

This tool can be used in combination with Art. A175 - B175 - C175

| S Ø 6 | S Ø 8 | D | R | B | L |
|-------------|-------------|------|----|----|----|
| A146.270.R | C146.270.R* | 27 | 17 | 17 | 57 |
| A146.335.R* | C146.335.R* | 33,5 | 9 | 15 | 57 |

* Selling out



Z050.002.N



Z053.002.N



Z054.002.N



Z051.002.R

HW OGEE BITS WITH BALL BEARING GUIDE Z=2

ART. A147 - B147 - C147

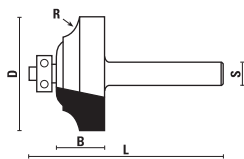

| S Ø 6 | S Ø 6,4 (1/4") | S Ø 8 | D | R | B | L |
|-------------|----------------|-------------|------|---|----|----|
| A147.318.R* | | C147.318.R* | 31,8 | 5 | 13 | 51 |
| A147.380.R | B147.380.R | C147.380.R* | 38 | 6 | 16 | 54 |

* Selling out



Z050.003.N



Z053.003.N



Z054.002.N



Z051.002.R

HW PANEL PILOT BITS WITH BALL BEARING GUIDE Z=1

ART. A150 - C150

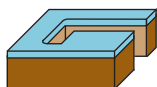
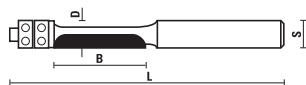

Ideal for working laminated panels

| S Ø 6 | S Ø 8 | D | B | L |
|------------|------------|-----|----|----|
| A150.064.R | C150.064.R | 6,4 | 19 | 57 |



Z050.017.N

HW FLUSH AND BEVEL TRIM BITS Z=2

ART. A151 - C151

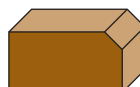
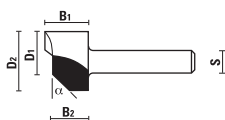

| S Ø 6 | S Ø 8 | D1 | D2 | B1 | B2 | α |
|------------|------------|----|----|----|----|--------|
| A151.200.R | C151.200.R | 20 | 24 | 15 | 11 | 0°/45° |

HW FLUSH AND BEVEL TRIM BITS WITH BALL BEARING GUIDE Z=2

ART. A152 - C152

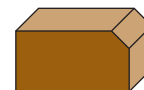
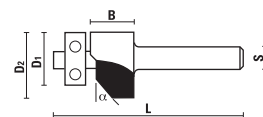

| S Ø 6 | S Ø 8 | D1 | D2 | B | L | α |
|------------|------------|----|----|----|----|--------|
| A152.190.R | C152.190.R | 19 | 26 | 15 | 53 | 0°/45° |



Z050.006.N

HW KEYHOLE BITS Z=1

ART. A153 - B153 - C153

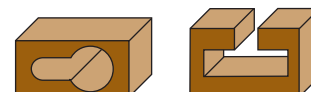
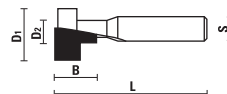

| S Ø 6 | S Ø 6,4 (1/4") | S Ø 8 | D1 | D2 | B | L |
|------------|----------------|------------|------|----|-----|------|
| A153.098.R | B153.098.R | C153.098.R | 9,8 | 5 | 9,8 | 38,1 |
| A153.127.R | B153.127.R | C153.127.R | 12,7 | 8 | 9,8 | 38,1 |

HW CONVEX EDGING BITS Z=2

ART. A154 - C154

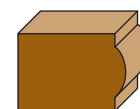
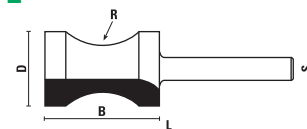

| S Ø 6 | S Ø 8 | D | R | B | L |
|-------------|------------|------|----|----|------|
| A154.202.R* | C154.202.R | 20,2 | 18 | 32 | 62,6 |

* Selling out

HW FINGER GRIP BITS Z=2

ART. A155

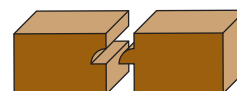
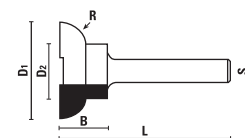

| S Ø 6 | D1 | D2 | R | B | L |
|------------|----|----|-----|----|----|
| A155.280.R | 28 | 15 | 6,4 | 13 | 41 |

HW DRAWER LOCK BITS Z=2

ART. A156

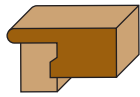
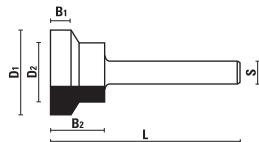

| S Ø 6 | D1 | D2 | B1 | B2 | L |
|------------|------|------|----|----|----|
| A156.254.R | 25,4 | 18,5 | 4 | 13 | 49 |

HW SEAL PROFILE BITS Z=2

ART. A157 - B157

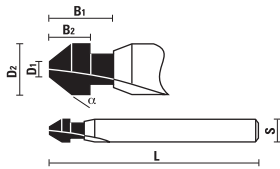

| S Ø 6 | S Ø 6,4 (1/4") | D1 | D2 | α | B1 | B2 | L |
|------------|----------------|----|-----|-----|----|----|----|
| A157.055.R | B157.055.R | 2 | 5,5 | 38° | 8 | 4 | 65 |

HW DOVETAIL SEAL BITS Z=2

ART. A158 - B158

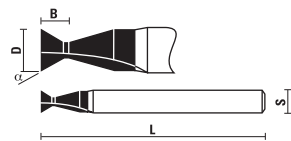

| S Ø 6 | S Ø 6,4 (1/4") | D | α | B | L |
|------------|----------------|-----|-----|---|----|
| A158.051.R | B158.051.R | 5,1 | 25° | 4 | 60 |

HW SEAL BITS Z=2

ART. A159 - B159

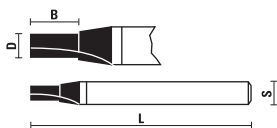

| S Ø 6 | S Ø 6,4 (1/4") | D | B | L |
|------------|----------------|---|---|----|
| A159.030.R | B159.030.R | 3 | 8 | 55 |

HW FLUSH TRIM BITS WITH UPPER BALL BEARING GUIDE Z=2

ART. A160 - B160

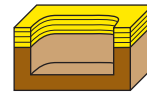
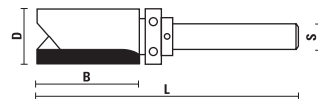

- Suitable for trimming and milling on every type of wood

| S Ø 6 | S Ø 6,4 (1/4") | D | B | L |
|-----------------------|-----------------------|------|------|----|
| A160.125.R NEW | B160.125.R NEW | 12,7 | 13 | 55 |
| A160.126.R NEW | B160.126.R NEW | 12,7 | 19 | 55 |
| A160.127.R | B160.127.R | 12,7 | 25,4 | 63 |
| A160.128.R | B160.128.R | 12,7 | 32 | 69 |



Z050.007.N



Z058.001.N



Z052.005.N



Z051.005.R

| S Ø 6 | S Ø 6,4 (1/4") | D | B | L |
|------------|----------------|------|----|---|
| A160.160.R | B160.160.R 16 | 25,4 | 63 | |
| | | | | |
| | | | | |
| | | | | |



Z050.011.N



Z058.001.N



Z052.005.N



Z051.005.R

| S Ø 8 | D | B | L |
|-----------------------|----|----|----|
| C160.161.R NEW | 16 | 32 | 69 |



Z050.018.N



Z058.004.N



Z052.005.N



Z051.005.R

| S Ø 6 | S Ø 6,4 (1/4") | D | B | L |
|------------|----------------|----|------|----|
| A160.190.R | B160.190.R | 19 | 25,4 | 63 |



Z050.005.N



Z058.001.N



Z052.005.N



Z051.005.R

HW FLUSH TRIM BITS WITH UPPER BALL BEARING GUIDE Z=2

ART. A161 - B161

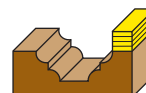
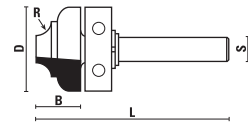

| S Ø 6 | S Ø 6,4 (1/4") | D | R | B | L |
|------------|----------------|----|-----|----|----|
| A161.220.R | B161.220.R | 22 | 3,5 | 11 | 51 |

ART. A162 - B162

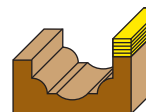
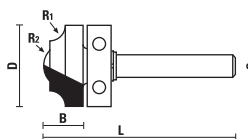

| S Ø 6 | S Ø 6,4 (1/4") | D | R1 | R2 | B | L |
|------------|----------------|----|----|-----|----|----|
| A162.220.R | B162.220.R | 22 | 4 | 5,5 | 12 | 51 |



Z050.008.N



DIN 471-15

HW FLUSH TRIM BITS WITH UPPER BALL BEARING GUIDE Z=2

ART. A163 - B163

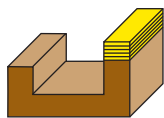
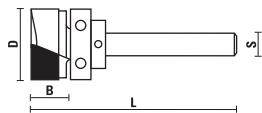

If shank Ø8 mm is needed, use bushings Art. Z001 see page 10.03

| S Ø 6 | S Ø 6,4 (1/4") | D | B | L |
|------------|----------------|------------|----|----|
| A163.190.R | B163.190.R | 19 | 11 | 56 |
| | | | | |
| Z050.005.N | Z058.001.N | Z051.005.R | | |

HW GROOVE BITS WITH UPPER BALL BEARING GUIDE Z=2

ART. A164 - B164

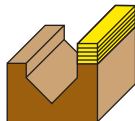
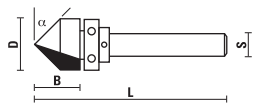

| S Ø 6 | S Ø 6,4 (1/4") | D | α | B | L |
|------------|----------------|------------|------------|----|----|
| A164.127.R | B164.127.R | 12,7 | 45° | 13 | 51 |
| | | | | | |
| Z050.007.N | Z058.001.N | Z052.005.N | Z051.005.R | | |

HW CORE BOX BITS WITH UPPER BALL BEARING GUIDE Z=2

ART. A165 - B165 - C165

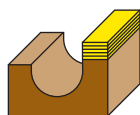
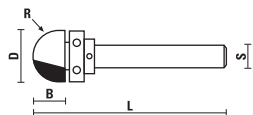

Suitable for cutting round-bottom groove that can be both decorative and functional on every type of wood.

| S Ø 6 | S Ø 6,4 (1/4") | D | R | B | L |
|------------|----------------|------------|-----|-----|----|
| A165.127.R | B165.127.R | 12,7 | 6,4 | 9,5 | 51 |
| | | | | | |
| Z050.007.N | Z058.001.N | Z051.005.R | | | |

| S Ø 6 | S Ø 6,4 (1/4") | S Ø 8 | D | R | B | L |
|----------------|----------------|----------------|----|---|----|----|
| A165.160.R NEW | B165.160.R NEW | C165.160.R NEW | 16 | 8 | 11 | 54 |
| | | | | | | |
| Z050.018.N | Z058.004.N | Z051.005.R | | | | |

| S Ø 6 | S Ø 6,4 (1/4") | D | R | B | L |
|----------------|----------------|------------|-----|----|----|
| A165.190.R NEW | B165.190.R NEW | 19 | 9,5 | 11 | 54 |
| | | | | | |
| Z050.006.N | Z058.005.N | Z051.005.R | | | |

| S Ø 8 | D | R | B | L |
|----------------|------------|------------|----|----|
| C165.190.R NEW | 19 | 9,5 | 11 | 54 |
| | | | | |
| Z050.026.N | Z058.006.N | Z051.005.R | | |

HW BOWL AND TRAY BITS WITH UPPER BALL BEARING GUIDE Z=2

ART. A166 - B166 - C166

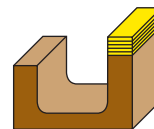
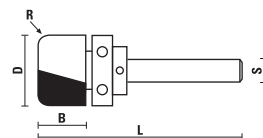

Suitable for making custom bowls, boxes, plates in any shape you can cut template for.

| S Ø 6 | S Ø 6,4 (1/4") | D | R | B | L |
|------------|----------------|------------|-----|----|----|
| A166.127.R | B166.127.R | 12,7 | 3,2 | 13 | 54 |
| | | | | | |
| Z050.007.N | Z058.001.N | Z051.005.R | | | |

| S Ø 6 | S Ø 6,4 (1/4") | D | R | B | L |
|------------|----------------|------------|-----|----|----|
| A166.190.R | B166.190.R | 19 | 6,4 | 16 | 59 |
| | | | | | |
| Z050.005.N | Z058.001.N | Z051.005.R | | | |

| S Ø 8 | D | R | B | L |
|----------------|------------|------------|----|----|
| C166.190.R NEW | 19 | 6,4 | 16 | 67 |
| | | | | |
| Z050.026.N | Z058.006.N | Z051.005.R | | |

HW FLUSH TRIM BITS WITH UPPER BALL BEARING GUIDE Z=2

ART. A167 - B167

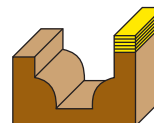
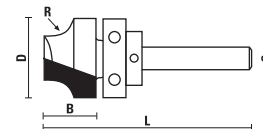

| S Ø 6 | S Ø 6,4 (1/4") | D | R | B | L |
|------------|----------------|------------|---|-----|----|
| A167.127.R | B167.127.R | 12,7 | 3 | 9,5 | 48 |
| | | | | | |
| Z050.007.N | Z058.001.N | Z051.005.R | | | |

| S Ø 6 | S Ø 6,4 (1/4") | D | R | B | L |
|------------|----------------|------------|---|----|----|
| A167.220.R | B167.220.R | 22 | 5 | 12 | 55 |
| | | | | | |
| Z050.008.N | Z058.001.N | Z051.005.R | | | |

| S Ø 6 | D | R | B | L |
|------------|------------|------------|----|----|
| A167.286.R | 28,6 | 8 | 15 | 58 |
| | | | | |
| Z050.015.N | Z058.003.N | Z051.005.R | | |

HW "LEAF-EDGE" BEADING BITS WITH DOUBLE BALL BEARING GUIDE Z=2

ART. A168 - B168

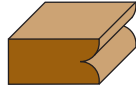
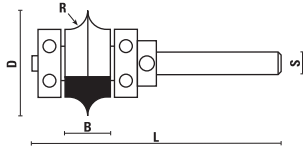

| S Ø 6 | S Ø 6,4 (1/4") | D | R | B | L |
|------------|----------------|------|-----|----|----|
| A168.254.R | B168.254.R | 25,4 | 4,8 | 13 | 66 |



Z050.011.N



Z058.001.N



Z053.002.N



Z051.004.R



Z051.005.R

HW "EDGE-FLUTING" BITS WITH DOUBLE BALL BEARING GUIDE Z=2

ART. A169 - B169

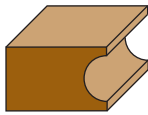
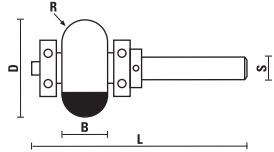

| S Ø 6 | S Ø 6,4 (1/4") | D | R | B | L |
|------------|----------------|----|---|----|----|
| A169.230.R | B169.230.R | 23 | 5 | 10 | 61 |



Z050.007.N superiore



Z058.001.N



Z051.005.R



Z050.003.N inferiore



Z053.003.N



Z054.002.R



Z051.002.R

HW RADIUS BITS WITH DOUBLE BALL BEARING GUIDE Z=2

ART. A170 - C170

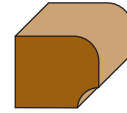
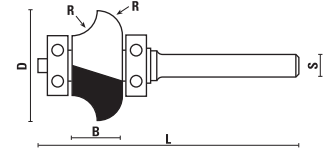

Patent

| S Ø 6 | S Ø 8 | D | R | B | L |
|-------------|-------------|------|-----|----|----|
| A170.285.R* | C170.285.R* | 28,5 | 6,4 | 14 | 66 |
| A170.320.R* | C170.320.R* | 32 | 8 | 17 | 69 |
| A170.350.R* | C170.350.R* | 35 | 9,5 | 20 | 72 |

* Selling out



Z050.018.N



Z058.001.N



Z051.005.R

T-SLOT HW CUTTERS Z=4

ART. C173

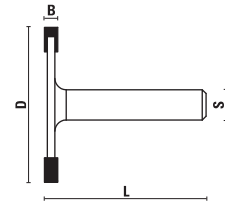

Four wings slot cutters for working plastic material

| S Ø 8 | D | B | L |
|-----------------------|----|-----|----|
| C173.020.R NEW | 41 | 2 | 43 |
| C173.025.R NEW | 41 | 2,5 | 43 |
| C173.030.R NEW | 41 | 3 | 44 |
| C173.035.R NEW | 41 | 3,5 | 44 |
| C173.040.R NEW | 41 | 4 | 45 |
| C173.045.R NEW | 41 | 4,5 | 45 |
| C173.050.R NEW | 41 | 5 | 46 |

HW DOUBLE DIAMETER BITS Z=2

ART. A180 - B180

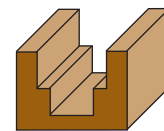
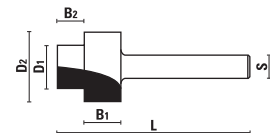

| S Ø 6 | S Ø 6,4 (1/4") | D1 | D2 | B1 | B2 | L |
|------------|----------------|------|----|-----|-----|----|
| A180.127.R | B180.127.R | 12,7 | 19 | 9,5 | 6,4 | 51 |



CONTACT US
 (+39) 0721 28950
 info@sistemiklein.com

HW DOUBLE RADIUS BITS Z=2

ART. A181 - C181

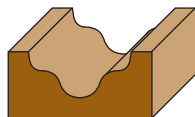
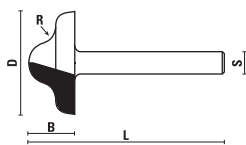

| S Ø 6 | S Ø 8 | D | R | B | L |
|-------------|------------|----|---|----|----|
| A181.270.R* | C181.270.R | 27 | 6 | 12 | 52 |

* Selling out

HW DOUBLE RADIUS BITS Z=2

ART. A182 - C182

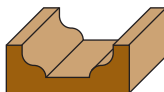
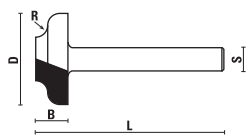

| S Ø 6 | S Ø 8 | D | R | B | L |
|-------------|------------|------|-----|-----|----|
| A182.254.R* | C182.254.R | 25,4 | 3,2 | 9,5 | 50 |

* Selling out

HW DOUBLE RADIUS BITS Z=2

ART. A185

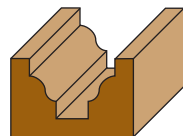
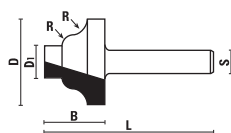

| S Ø 6 | D | D ₁ | R | B | L |
|-------------|----|----------------|-----|----|----|
| A185.210.R* | 21 | 8 | 3,2 | 13 | 42 |
| A185.250.R* | 25 | 8 | 4 | 17 | 45 |

* Selling out

HW DOUBLE RADIUS BITS Z=2

ART. A186 - B186

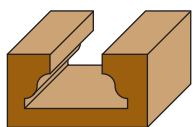
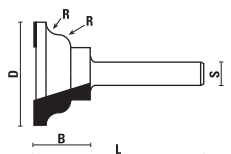

| S Ø 6 | S Ø 6,4 (1/4") | D | D ₁ | R | B | L |
|-------------|----------------|----|----------------|-----|----|----|
| A186.250.R | B186.250.R | 25 | 12 | 3,2 | 13 | 42 |
| A186.290.R* | | 29 | 12 | 4 | 17 | 45 |

* Selling out

HW MULTI RADIUS BITS Z=2

ART. A191

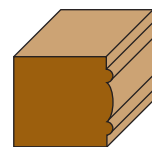
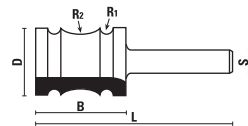

| S Ø 6 | D | R ₁ | R ₂ | B | L |
|------------|----|----------------|----------------|----|----|
| A191.190.R | 19 | 2 | 6 | 25 | 55 |

HW 45 DEGREE LOCK MITRE JOINT BITS Z=2

ART. A195 - B195

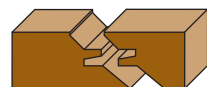
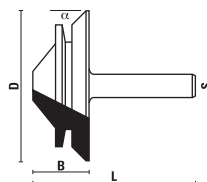

| S Ø 6 | S Ø 6,4 (1/4") | D | α | B | L |
|------------|----------------|----|-----|----|----|
| A195.420.R | B195.420.R | 42 | 45° | 16 | 45 |

HW BOWL AND TRAY BITS Z=2

ART. A196 - B196 - C196

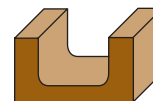
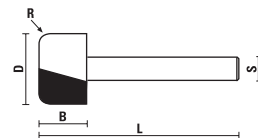

Suitable for cutting hollows into bowls, boxes, plates, serving trays and spoon

| S Ø 6 | S Ø 6,4 (1/4") | S Ø 8 | D | R | B | L |
|----------------|----------------|----------------|----|-----|------|----|
| | | C196.110.R NEW | 11 | 3 | 12,7 | 54 |
| A196.190.R NEW | B196.190.R NEW | C196.190.R NEW | 19 | 6,4 | 16 | 60 |



HW ADJUSTABLE COUNTERSINKS Z=2

ART. A199

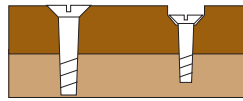
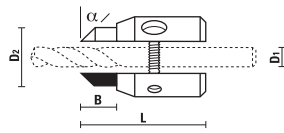

- Spare key supplied; single packed
- On request display free of charge by min order 10 pcs.



| Item | D1 | D2 | α | B | L |
|-----------------------|------|-----------|-----|----|----|
| A199.030.R | 3/7 | 11/15 | 45° | 12 | 32 |
| A199.060.R NEW | 6/10 | 15,5/19,5 | 45° | 12 | 34 |

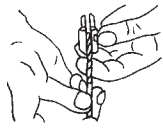

Insert the tool



Adjust the boring depth

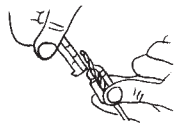

Line up the cutting edges of countersink and tool



Tighten the screws

HS FLUSH TRIMMERS FOR TABLE EDGE BANDING MACHINES

ART. AG

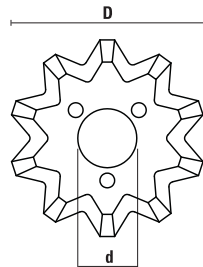

To be used on "VITAP" machines

| Item | D | d | B | Z |
|-------------|----|----|-----|----|
| AG040.01012 | 40 | 12 | 1,1 | 10 |

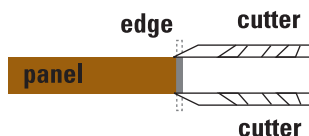

HW PLUNGE TYPE STRAIGHT BITS FOR "ELU" Z=2+1

ART. C190

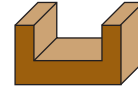
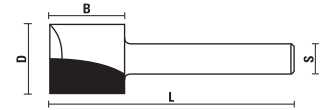

Straight cut plunging

| S Ø 8 | D | B | L | Z |
|--------------|----|----|-----|-----|
| C190.030.R ▲ | 3 | 10 | 55 | 2+1 |
| C190.040.R ▲ | 4 | 12 | 55 | 2+1 |
| C190.050.R ▲ | 5 | 14 | 55 | 2+1 |
| C190.060.R ▲ | 6 | 16 | 55 | 2+1 |
| C190.070.R ▲ | 7 | 18 | 55 | 2+1 |
| C190.080.R ▲ | 8 | 20 | 55 | 2+1 |
| C190.081.R ▲ | 8 | 40 | 90 | 2+1 |
| C190.090.R ▲ | 9 | 20 | 55 | 2+1 |
| C190.100.R ▲ | 10 | 20 | 55 | 2+1 |
| C190.101.R | 10 | 30 | 70 | 2+1 |
| C190.102.R | 10 | 40 | 90 | 2+1 |
| C190.120.R | 12 | 20 | 60 | 2+1 |
| C190.121.R | 12 | 20 | 100 | 2+1 |
| C190.122.R | 12 | 30 | 70 | 2+1 |
| C190.123.R | 12 | 40 | 90 | 2+1 |
| C190.140.R | 14 | 20 | 60 | 2+1 |
| C190.141.R | 14 | 20 | 100 | 2+1 |
| C190.142.R | 14 | 40 | 90 | 2+1 |
| C190.150.R | 15 | 20 | 70 | 2+1 |
| C190.160.R | 16 | 20 | 70 | 2+1 |
| C190.161.R | 16 | 20 | 100 | 2+1 |
| C190.162.R | 16 | 40 | 90 | 2+1 |
| C190.163.R | 16 | 30 | 70 | 2+1 |
| C190.180.R | 18 | 20 | 70 | 2+1 |
| C190.181.R | 18 | 30 | 70 | 2+1 |
| C190.182.R | 18 | 40 | 90 | 2+1 |
| C190.200.R | 20 | 20 | 70 | 2+1 |
| C190.201.R | 20 | 20 | 100 | 2+1 |
| C190.202.R | 20 | 30 | 70 | 2+1 |
| C190.203.R | 20 | 40 | 90 | 2+1 |
| C190.220.R | 22 | 16 | 70 | 2+1 |
| C190.221.R | 22 | 20 | 100 | 2+1 |
| C190.222.R | 22 | 30 | 70 | 2+1 |
| C190.223.R | 22 | 40 | 90 | 2+1 |
| C190.240.R | 24 | 16 | 70 | 2+1 |
| C190.241.R | 24 | 30 | 70 | 2+1 |
| C190.250.R | 25 | 16 | 70 | 2+1 |

▲ Solid Carbide

visit our website

www.sistemiklein.com



HW BORING BITS

ART. C192

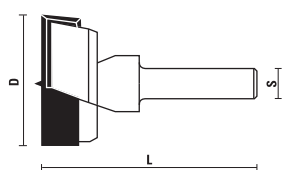

Without spurs



| RH rotation | D | L | S |
|-------------|----|----|---|
| C192.250.R | 25 | 57 | 8 |
| C192.260.R | 26 | 57 | 8 |
| C192.300.R | 30 | 57 | 8 |
| C192.350.R | 35 | 57 | 8 |

HS COUNTERSINKS

ART. C240

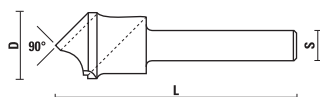

| S Ø 8x30 | D | L |
|------------|----|----|
| C240.160.R | 16 | 55 |

BUSHINGS

ART. Z001

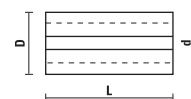

| Item | D | d | L |
|------------|------|-----|----|
| Z001.001.N | 8 | 6 | 25 |
| Z001.002.N | 9,5 | 6 | 25 |
| Z001.003.N | 9,5 | 8 | 25 |
| Z001.004.N | 10 | 8 | 25 |
| Z001.005.N | 12 | 8 | 25 |
| Z001.006.N | 12 | 6 | 25 |
| Z001.009.N | 8 | 6,4 | 25 |
| Z001.011.N | 10 | 6 | 25 |
| Z001.017.N | 9,5 | 6,4 | 25 |
| Z001.019.N | 12,7 | 8 | 25 |
| Z001.020.N | 12,7 | 6,4 | 25 |

SPACERS

ART. Z057

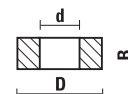

| Item | D | d | B |
|------------|-----|------|------|
| Z057.001.N | 16 | 7,94 | 3,6 |
| Z057.002.N | 16 | 7,94 | 1 |
| Z057.003.N | 16 | 7,94 | 0,5 |
| Z057.004.N | 16 | 7,94 | 0,1 |
| Z057.005.N | 16 | 7,94 | 3 |
| Z057.006.N | 16 | 7,94 | 6 |
| Z057.007.N | 16 | 7,94 | 0,4 |
| Z057.008.N | 16 | 7,94 | 0,05 |
| Z057.009.N | 16 | 7,94 | 5,3 |
| Z057.010.N | 9,5 | 6,4 | 2,2 |
| Z057.101.N | 10 | 6 | 1 |
| Z057.102.N | 10 | 6 | 1,5 |
| Z057.103.N | 10 | 6 | 3 |

INSERT ROUTER BITS FOR PORTABLE ROUTERS

Always looking for innovative products and most useful solutions, **SISTEMI** has developed a new line of **Klein** router bits with interchangeable carbide knives, which have a higher hardness than the tips used in traditional brazed router bits.

- The main advantages granted by the use of HW reversible knives and the possibility of their easy replacement are:
- **Longer tool life** ⇒ the knives are getting less worn out and in case of damage they can be easily replaced;
 - **Better finish quality** ⇒ also working abrasive materials, the cutting edge can be maintained always sharp;
 - **Higher measures precision** ⇒ the dimensions of the tools are not changing because there is no resharping;
 - **Better Quality/Price ratio** ⇒ higher production efficiency, less costs and better performances.

HW INSERT FLUSH TRIMMING BITS Z=1

ART. WC101

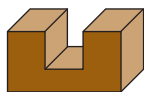
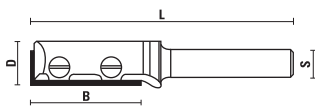

Complete with reversible knives

| S Ø 8 | D | B | L |
|-------------|------------|------|----|
| WC101.120.R | 12 | 29,5 | 66 |
| | | | |
| Z055.330.N | Z051.501.R | | |

HW INSERT V-GROOVING BITS Z=1

ART. WC109

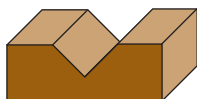
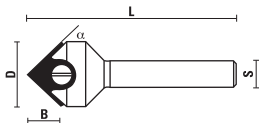

Complete with reversible knives

| S Ø 8 | D | B | α | L |
|-------------|------------|-----|-----|----|
| WC109.176.R | 17,6 | 8,5 | 45° | 53 |
| | | | | |
| Z055.001.N | Z051.501.R | | | |

AHW INSERT CORE BOX BITS WITH UPPER BALL BEARING Z=1

ART. WC111

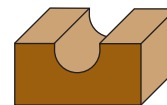
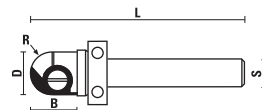

Complete with reversible knives

| S Ø 8 | D | B | R | L |
|-------------|------------|------------|---|----|
| WC111.127.R | 12,7 | 13 | 6 | 59 |
| | | | | |
| Z050.018.N | Z055.550.N | Z051.501.R | | |

HW INSERT FLUSH TRIMMING BITS WITH BALL BEARING

ART. WC120

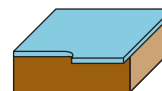
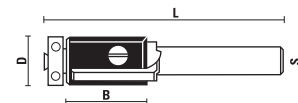

Complete with reversible knives

| S Ø 8 | D | B | L | Z |
|-------------|------------|--------------------------------------|--------------------------------|---|
| WC120.127.R | 12,7 | 20 | 62 | 2 |
| | | | | |
| Z050.003.N | Z055.551.N | Z051.503.N Screw for ball bearing | Z051.501.R Screw for knives | |

HW INSERT RABBET BITS WITH BALL BEARING Z=2

ART. WC121

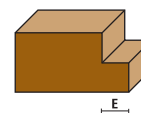
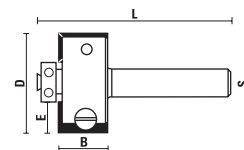

Complete with reversible knives

| S Ø 8 | D | B | E | L |
|-------------|------------|--------------------------------------|--------------------------------|----|
| WC121.286.R | 28,6 | 13,2 | 7,95 | 48 |
| | | | | |
| Z050.002.N | Z055.552.N | Z051.503.N Screw for ball bearing | Z051.501.R Screw for knives | |

HW INSERT FLUSH TRIMMING BITS WITH BALL BEARING Z=2

ART. WC122

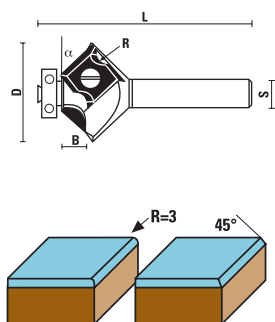

- Complete with reversible knives
- The same knives can be used for both 45° and R= 3 bevel



| S Ø 8 | D | B | R | α | L |
|-------------|------|-----|---|-----|----|
| WC122.273.R | 27,3 | 5,7 | 3 | 45° | 59 |



Z050.003.N



Z055.553.N



Z051.503.N

Screw for ball bearing



Z051.501.R

Screw for knives

HW INSERT CORNER ROUNDING BITS WITH BALL BEARING Z=2

ART. WC123

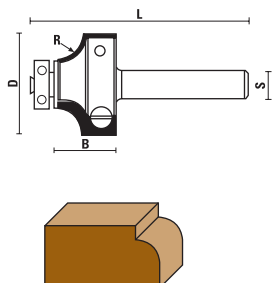

Complete with reversible knives



| S Ø 8 | D | B | R | L |
|-------------|----|------|---|----|
| WC123.260.R | 26 | 15,7 | 6 | 55 |



Z050.003.N



Z055.554.N



Z051.503.N

Screw for ball bearing



Z051.501.R

Screw for knives

HW INSERT COVER BITS WITH BALL BEARING Z=2

ART. WC125

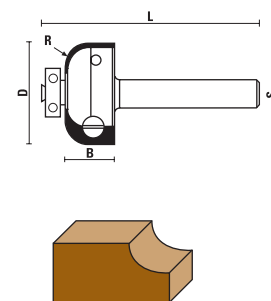

Complete with reversible knives



| S Ø 8 | D | B | R | L |
|-------------|----|------|---|----|
| WC125.260.R | 26 | 12,7 | 6 | 55 |



Z050.003.N



Z055.555.N



Z051.503.N

Screw for ball bearing



Z051.501.R

Screw for knives

HW INSERT OGEE BITS WITH BALL BEARING Z=2

ART. WC129

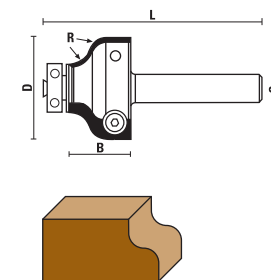

Complete with reversible knives



| S Ø 8 | D | B | R | L |
|-------------|----|------|-----|----|
| WC129.260.R | 26 | 15,7 | 4,5 | 55 |



Z050.003.N



Z055.556.N



Z051.503.N

Screw for ball bearing



Z051.501.R

Screw for knives

6 PIECE STRAIGHT-DOVETAIL INSERT ROUTER BITS "STARTER SET"

ART. X001



- Set including the 6 most popular T.C.T. router bits in a robust and practical wooden box.
- Ideal to have always on hand the right bit for straight cuts, trimming and engraving.

| Item | | |
|-----------------------|-----------------------------|-----------------------|
| X001.006.R (S Ø 6) | X001.064.R (S Ø 6,4 (1/4")) | X001.008.R (S Ø 8) |
| 6-pcs router bit set: | 6-pcs router bit set: | 6-pcs router bit set: |
| A101.060.R | B101.064.R | C101.060.R |
| A101.160.R | B101.160.R | C101.160.R |
| A105.064.R | B105.064.R | C105.064.R |
| A108.127.R | B108.127.R | C108.127.R |
| A109.127.R | B109.127.R | C109.127.R |
| A119.127.R | B119.127.R | C119.127.R |

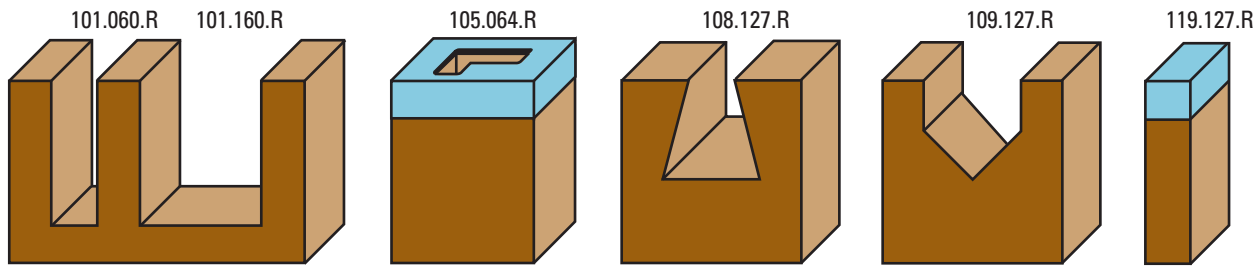

Scale 1:1

6 PIECE PROFILE ROUTER BITS "STARTER SET"

ART. X002



- Set including the 6 most popular T.C.T. router bits in a robust and practical wooden box.
- Ideal to have always on hand the right bit for straight cuts, trimming and profiling.

| Item | | |
|-----------------------|-----------------------------|-----------------------|
| X002.006.R (S Ø 6) | X002.064.R (S Ø 6,4 (1/4")) | X002.008.R (S Ø 8) |
| 6-pcs router bit set: | 6-pcs router bit set: | 6-pcs router bit set: |
| A101.060.R | B101.064.R | C101.060.R |
| A119.127.R | B119.127.R | C119.127.R |
| A122.317.R | B122.317.R | C122.317.R |
| A123.254.R | B123.254.R | C123.254.R |
| A125.254.R | B125.254.R | C125.254.R |
| A127.254.R | B127.254.R | C127.254.R |

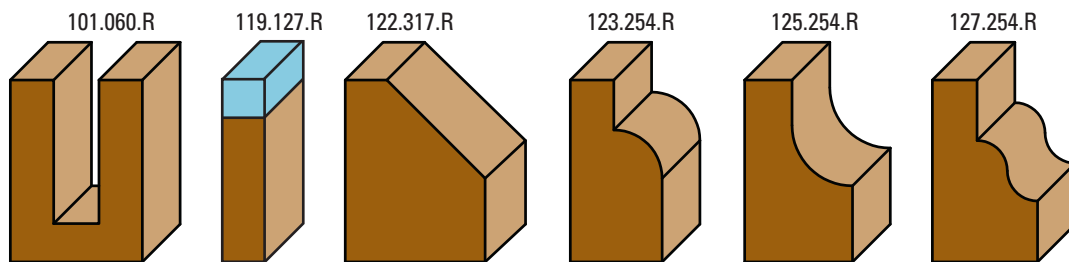

Scale 1:1

6 PIECE STRAIGHT BITS "STARTER SET"

ART. X003



- Set including the 6 most popular T.C.T. router bits in a robust and practical wooden box.
- Ideal to have always on hand the right bit for straight cuts.

| Item | | |
|-----------------------|-----------------------------|-----------------------|
| X003.006.R (S Ø 6) | X003.064.R (S Ø 6,4 (1/4")) | X003.008.R (S Ø 8) |
| 6-pcs router bit set: | 6-pcs router bit set: | 6-pcs router bit set: |
| A101.030.R | B101.030.R | C101.030.R |
| A101.040.R | B101.040.R | C101.040.R |
| A101.060.R | B101.060.R | C101.060.R |
| A101.080.R | B101.080.R | C101.080.R |
| A103.100.R | B103.100.R | C103.100.R |
| A103.120.R | B103.120.R | C103.120.R |

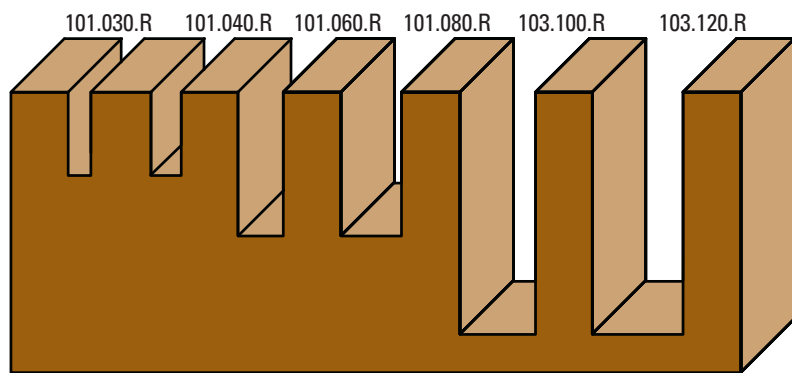

Scale 1:1

6 PIECE CORNER ROUNDING BITS "STARTER SET"

ART. X011



- Set including the 6 most popular T.C.T. router bits in a robust and practical wooden box.
- Ideal to have always on hand the right bit to produce corner roundings.

| Item | | |
|-----------------------|-----------------------------|-----------------------|
| X011.006.R (S Ø 6) | X011.064.R (S Ø 6,4 (1/4")) | X011.008.R (S Ø 8) |
| 6-pcs router bit set: | 6-pcs router bit set: | 6-pcs router bit set: |
| A123.167.R | B123.167.R | C123.167.R |
| A123.187.R | B123.187.R | C123.187.R |
| A123.207.R | B123.207.R | C123.207.R |
| A123.227.R | B123.227.R | C123.227.R |
| A123.247.R | B123.247.R | C123.247.R |
| A123.286.R | B123.286.R | C123.286.R |

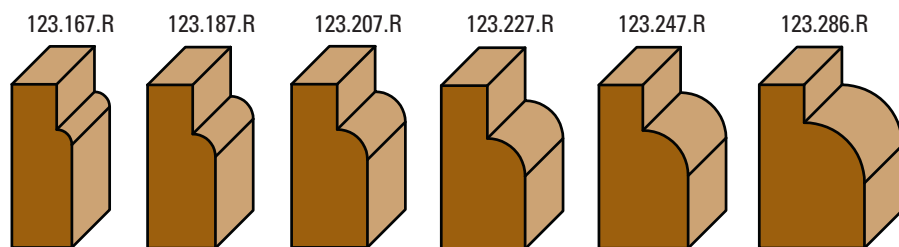

Scale 1:1

6 PIECE DOVETAIL BITS "STARTER SET"

ART. X012



- Set including the 6 most popular T.C.T. router bits in a robust and practical wooden box.
- Ideal to have the right bit for straight cuts and dovetail joints.

| Item | | |
|-----------------------|-----------------------------|-----------------------|
| X012.006.R (S Ø 6) | X012.064.R (S Ø 6,4 (1/4")) | X012.008.R (S Ø 8) |
| 6-pcs router bit set: | 6-pcs router bit set: | 6-pcs router bit set: |
| A101.060.R | B101.060.R | C101.060.R |
| A102.080.R | B102.080.R | C102.080.R |
| A108.064.R | B108.064.R | C108.064.R |
| A108.095.R | B108.095.R | C108.095.R |
| A108.150.R | B108.150.R | C108.150.R |
| A108.190.R | B108.190.R | C108.190.R |

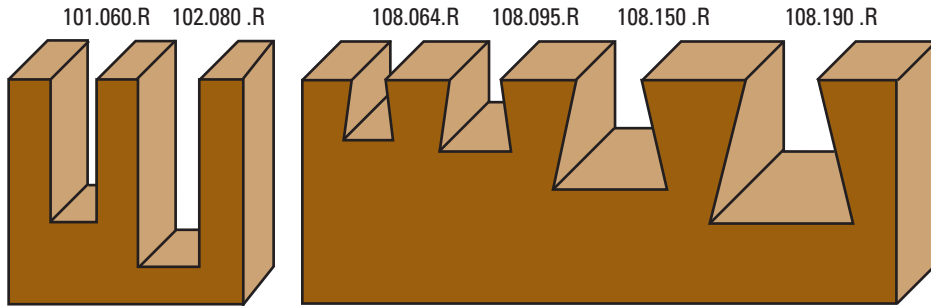

Scale 1:1

12 PIECE CLASSICAL ROUTER BITS "STARTER SET"

ART. X005



- Set including the 12 most popular T.C.T. router bits in a robust and practical wooden box.
- Ideal to have always on hand the right bit for straight cuts, trimming, engraving and profiling.

| Item | | |
|------------------------|-----------------------------|------------------------|
| X005.006.R (S Ø 6) | X005.064.R (S Ø 6,4 (1/4")) | X005.008.R (S Ø 8) |
| 12-pcs router bit set: | 12-pcs router bit set: | 12-pcs router bit set: |
| A101.060.R | B101.064.R | C101.060.R |
| A101.120.R | B101.127.R | C101.120.R |
| A101.200.R | B101.190.R | C101.200.R |
| A105.064.R | B105.064.R | C105.064.R |
| A108.127.R | B108.127.R | C108.127.R |
| A109.127.R | B109.127.R | C109.127.R |
| A111.127.R | B111.127.R | C111.127.R |
| A119.127.R | B119.127.R | C119.127.R |
| A122.317.R | B122.317.R | C122.317.R |
| A123.254.R | B123.254.R | C123.254.R |
| A125.254.R | B125.254.R | C125.254.R |
| A127.254.R | B127.254.R | C127.254.R |

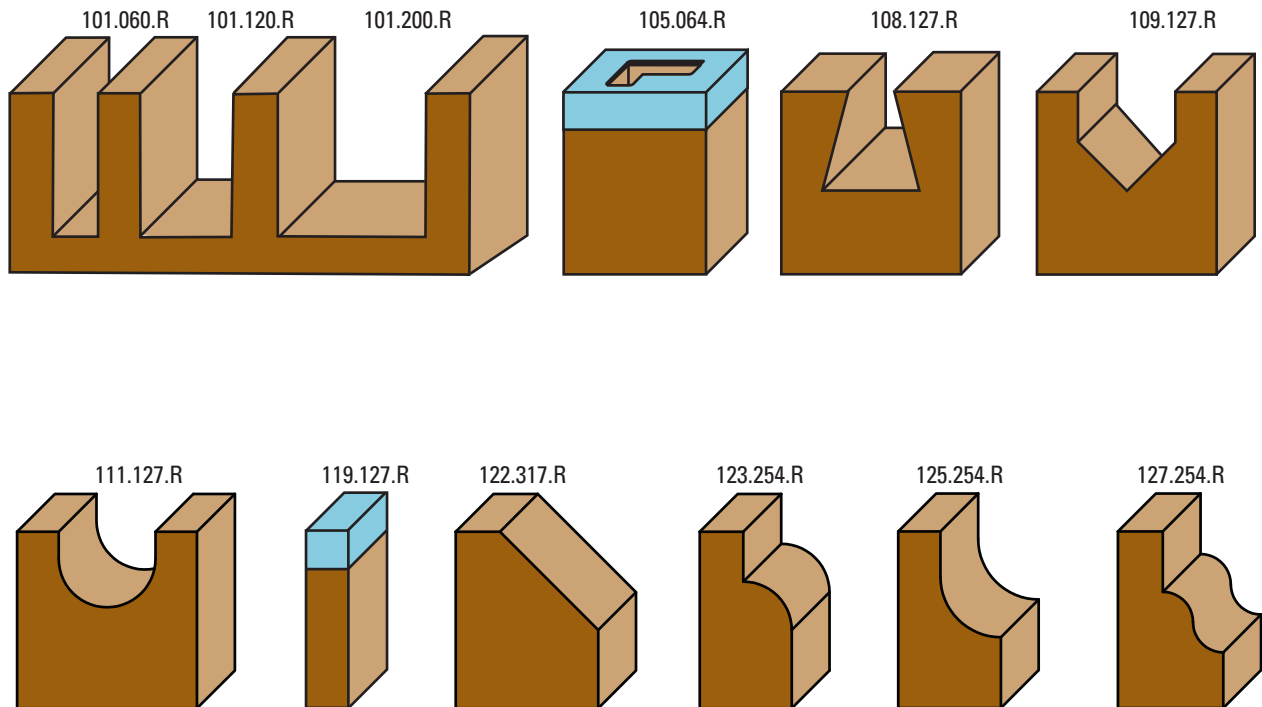

Scale 1:1

12 PIECE STRAIGHT BITS "ADVANCED SET"

ART. X006



- Set including the 12 most popular T.C.T. router bits in a robust and practical wooden box.
- Ideal to have always on hand the right bit for straight cuts.

| Item | | |
|------------------------|-----------------------------|------------------------|
| X006.006.R (S Ø 6) | X006.064.R (S Ø 6,4 (1/4")) | X006.008.R (S Ø 8) |
| 12-pcs router bit set: | 12-pcs router bit set: | 12-pcs router bit set: |
| A101.030.R | B101.030.R | C101.030.R |
| A101.040.R | B101.040.R | C101.040.R |
| A101.060.R | B101.060.R | C101.060.R |
| A101.080.R | B101.080.R | C101.080.R |
| A101.100.R | B101.100.R | C101.100.R |
| A101.120.R | B101.120.R | C101.120.R |
| A102.060.R | B102.060.R | C102.060.R |
| A102.080.R | B102.080.R | C102.080.R |
| A102.100.R | B102.100.R | C102.100.R |
| A103.080.R | B103.080.R | C103.080.R |
| A103.100.R | B103.100.R | C103.100.R |
| A103.120.R | B103.120.R | C103.120.R |

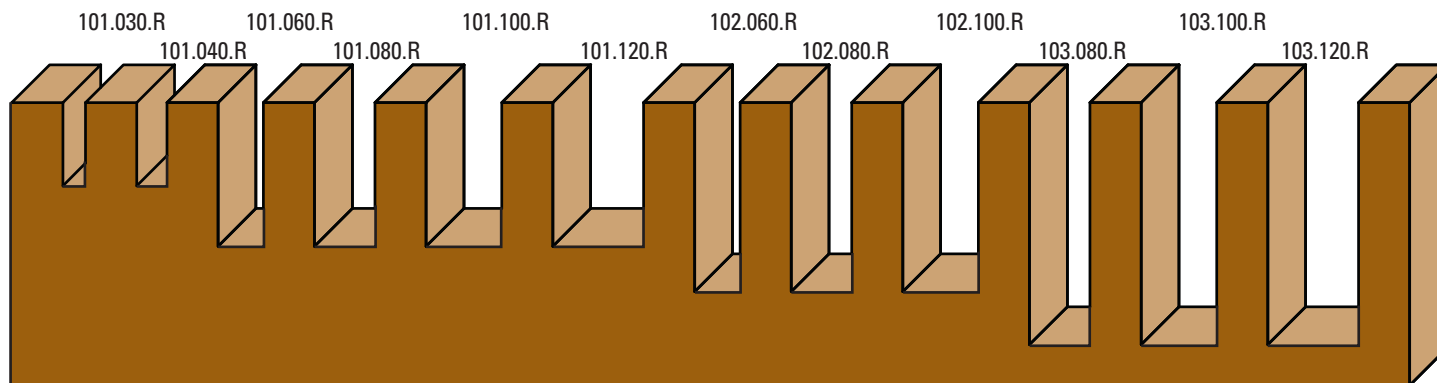

Scale 1:1

12 PIECE PROFILE ROUTER BITS "ADVANCED SET"

ART. X007



- Set including the 12 most popular T.C.T. router bits in a robust and practical wooden box.
- Ideal to have always on hand the right bit for trimming and profiling.

| Item | | |
|------------------------|-----------------------------|------------------------|
| X007.006.R (S Ø 6) | X007.064.R (S Ø 6,4 (1/4")) | X007.008.R (S Ø 8) |
| 12-pcs router bit set: | 12-pcs router bit set: | 12-pcs router bit set: |
| A119.190.R | B119.190.R | C119.190.R |
| A120.127.R | B120.127.R | C120.127.R |
| A121.317.R | B121.317.R | C121.317.R |
| A122.317.R | B122.317.R | C122.317.R |
| A123.167.R | B123.167.R | C123.167.R |
| A123.187.R | B123.187.R | C123.187.R |
| A123.207.R | B123.207.R | C123.207.R |
| A123.227.R | B123.227.R | C123.227.R |
| A123.247.R | B123.247.R | C123.247.R |
| A123.286.R | B123.286.R | C123.286.R |
| A125.254.R | B125.254.R | C125.254.R |
| A127.254.R | B127.254.R | C127.254.R |

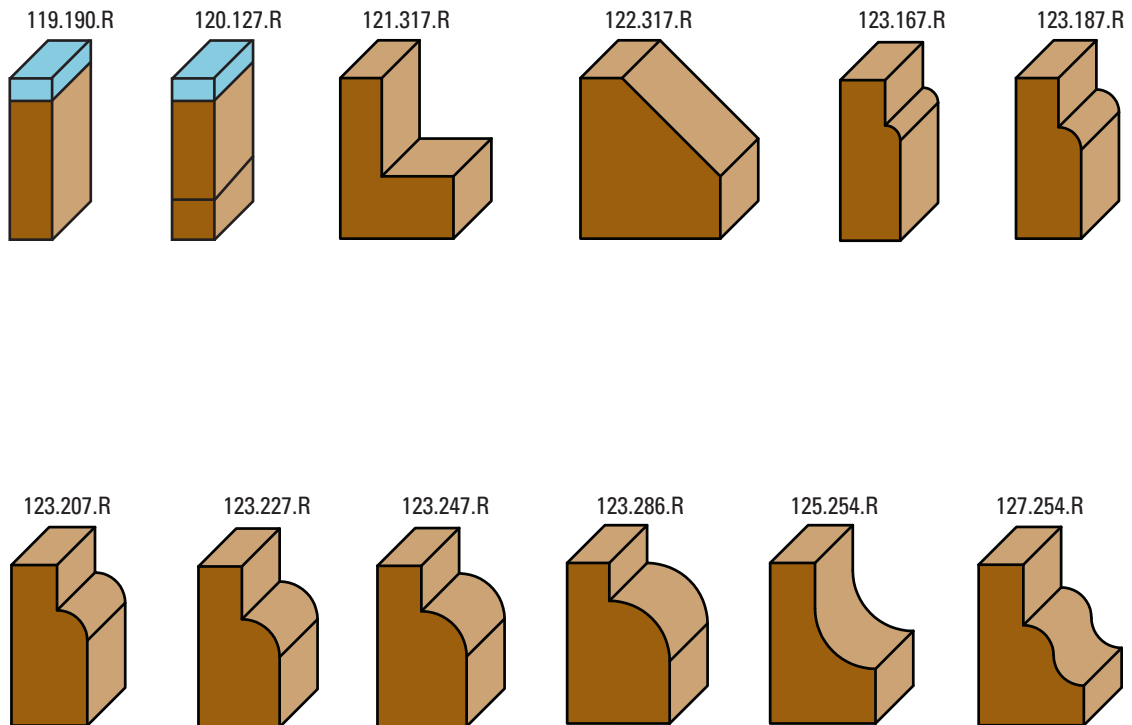

Scale 1:1

12 PIECE DOVETAIL BITS "ADVANCED SET"

ART. X008



- Set including the 12 most popular T.C.T. router bits in a robust and practical wooden box.
- Ideal to have the right bit for straight cuts and dovetail joints.

| Item | | |
|------------------------|-----------------------------|------------------------|
| X008.006.R (S Ø 6) | X008.064.R (S Ø 6,4 (1/4")) | X008.008.R (S Ø 8) |
| 12-pcs router bit set: | 12-pcs router bit set: | 12-pcs router bit set: |
| A101.030.R | B101.030.R | C101.030.R |
| A101.040.R | B101.040.R | C101.040.R |
| A102.060.R | B102.060.R | C102.060.R |
| A102.080.R | B102.080.R | C102.080.R |
| A108.064.R | B108.064.R | C108.064.R |
| A108.080.R | B108.080.R | C108.080.R |
| A108.095.R | B108.095.R | C108.095.R |
| A108.127.R | B108.127.R | C108.127.R |
| A108.143.R | B108.143.R | C108.143.R |
| A108.150.R | B108.150.R | C108.150.R |
| A108.160.R | B108.160.R | C108.160.R |
| A108.190.R | B108.190.R | C108.190.R |

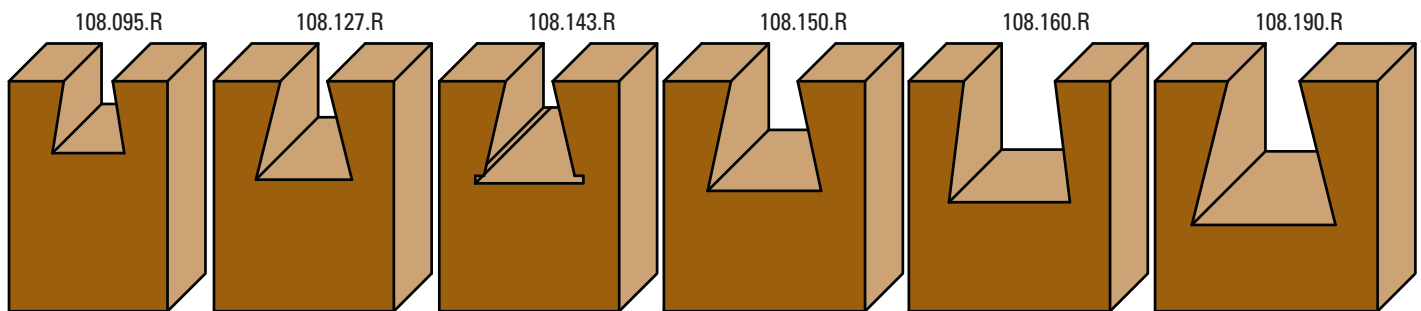
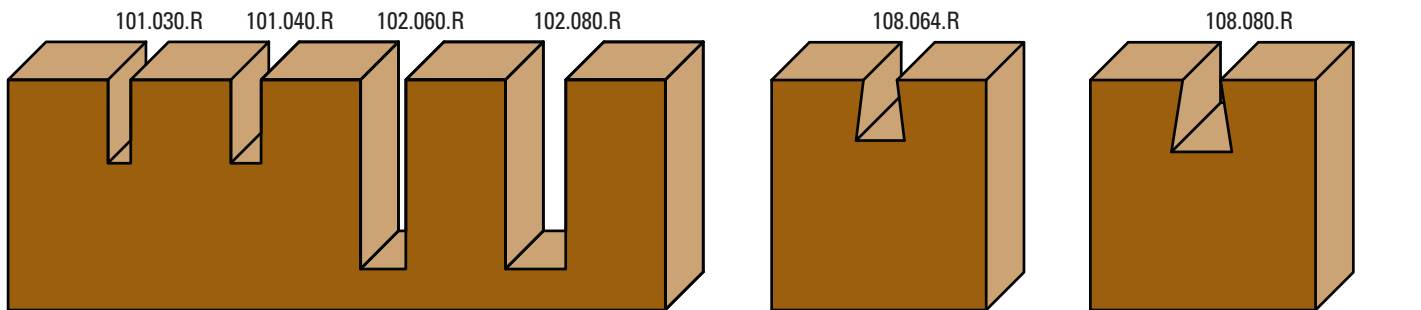

Scale 1:1

12 PIECE CORNER ROUNDING BITS "ADVANCED SET"

ART. X013



- Set including the 12 most popular T.C.T. router bits in a robust and practical wooden box.
- Ideal to have always on hand the right bit to produce corner roundings.

| Item | |
|------------------------|------------------------|
| X013.006.R (S Ø 6) | X013.008.R (S Ø 8) |
| 12-pcs router bit set: | 12-pcs router bit set: |
| A123.160.R | C123.160.R |
| A123.167.R | C123.167.R |
| A123.187.R | C123.187.R |
| A123.190.R | C123.190.R |
| A123.207.R | C123.207.R |
| A123.222.R | C123.222.R |
| A123.227.R | C123.227.R |
| A123.247.R | C123.247.R |
| A123.254.R | C123.254.R |
| A123.286.R | C123.286.R |
| A123.318.R | C123.318.R |
| A123.327.R | C123.327.R |

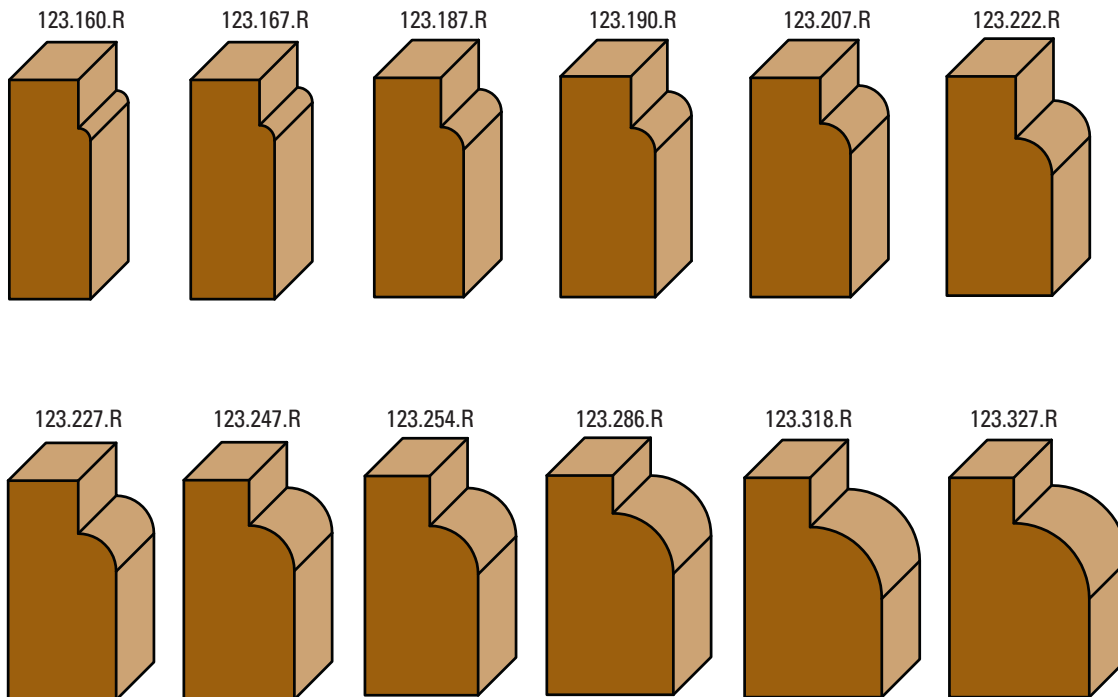

Scale 1:1

6 PIECE INSERT ROUTER BITS "SET"

ART. XWC



- Set including the 6 most popular HW router bits in S=8 in a robust and practical wooden box.
- Ideal to have always on hand the right bit for straight cuts, trimming and engraving.
- Router bits complete with reversible knives

Item

XWC.001.R

6-pcs router bit set:

WC101.120.R

WC109.176.R

WC111.127.R

WC120.127.R

WC121.286.R

WC122.273.R

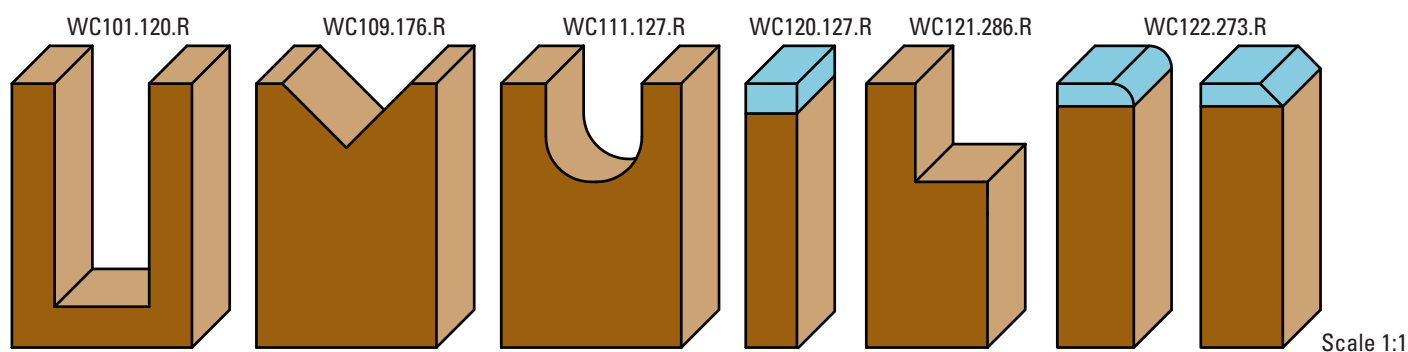

Scale 1:1

6 PIECE INSERT ROUTER BITS "SET"

ART. XWC



- Set including the 6 most popular HW router bits in S=8 in a robust and practical wooden box.
- Ideal to have always on hand the right bit for trimming and profiling.
- Router bits complete with reversible knives

Item

XWC.002.R

6-pcs router bit set:

WC120.127.R

WC121.286.R

WC122.273.R

WC123.260.R

WC125.260.R

WC129.260.R

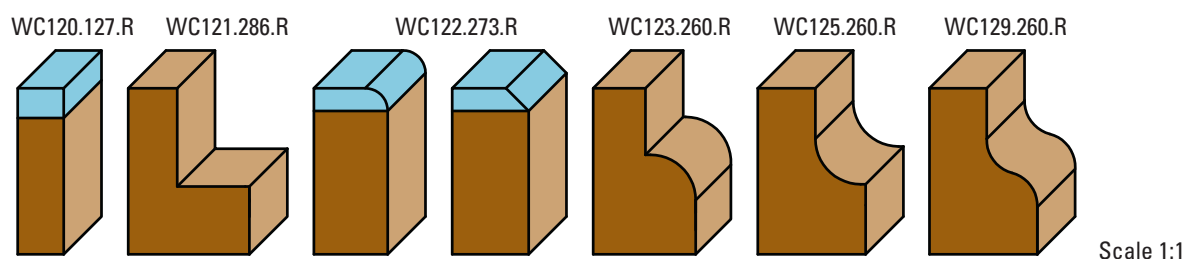

Scale 1:1

BASE

1 modular panel

Small display, ideal for starting with a basic assortment
Dimensions (cm): 110 (L) x 90 (H) x 30 (P)



Display code **Base 01**
 includes:
 Router bits S=6/8
 for portable routers
60 positions



Display code **Base 02**
 includes:
 Router bits S=12
 for portable routers
30 positions

**Display
 customizable**

STANDARD

2 modular panels

Consisting of two displays "BASE", can be composed according to customers' needs.
 Suitable for those who want a good variety of products waiting to increase and improve the offer range.

Dimensions (cm): 110 (L) x 145 (H) x 36 (P)

Display code **Standard 01**
 includes:
 Router bits S=6/8 for portable routers
120 positions

Display code **Standard 02**
 includes:
 Router bits S=12 for portable routers
60 positions

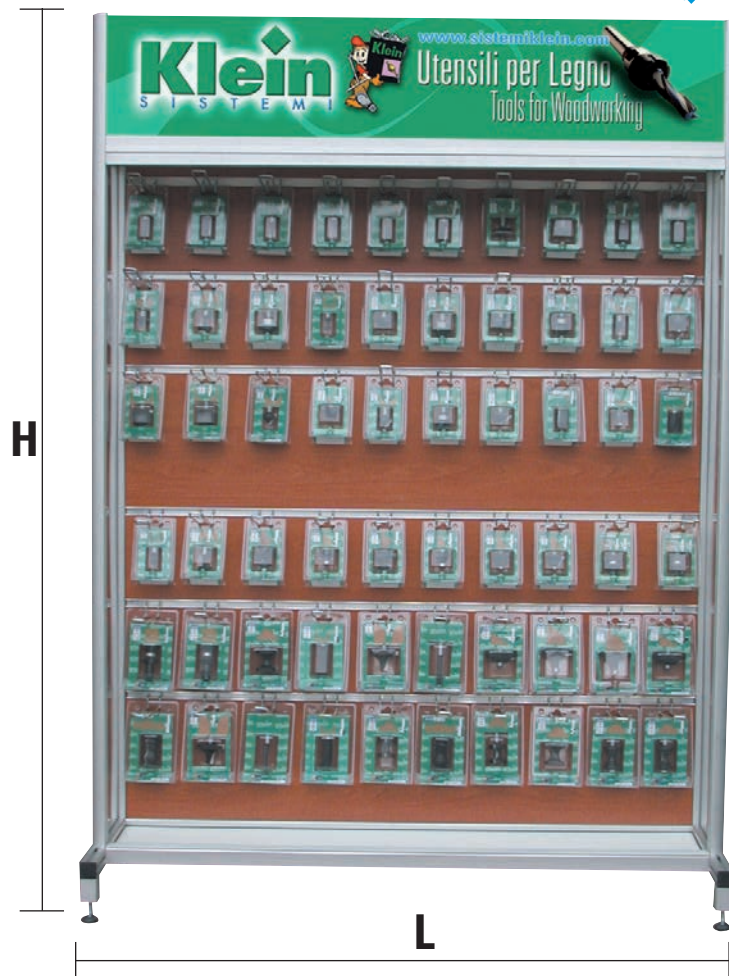
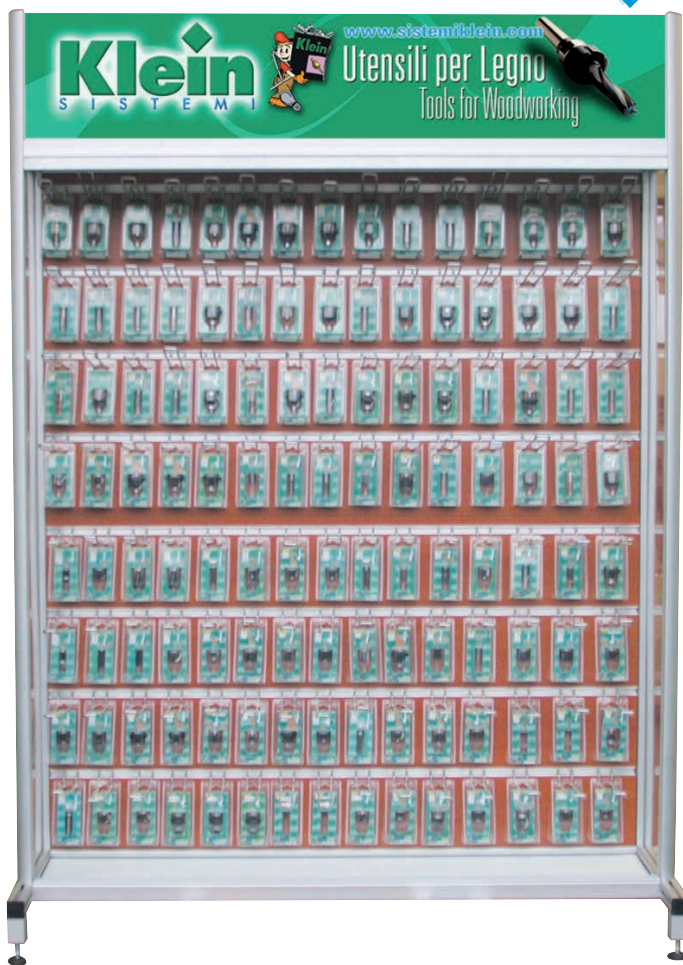

PROFESSIONAL

3 modular panels

Big display consisting of three panels BASE, allows you to display a large variety of items.
With two or more displays you get the complete assortment to meet all the needs of professional woodworkers.

Dimensions (cm): 110 (L) x 200 (H) x 36 (P)

**Display
customizable**

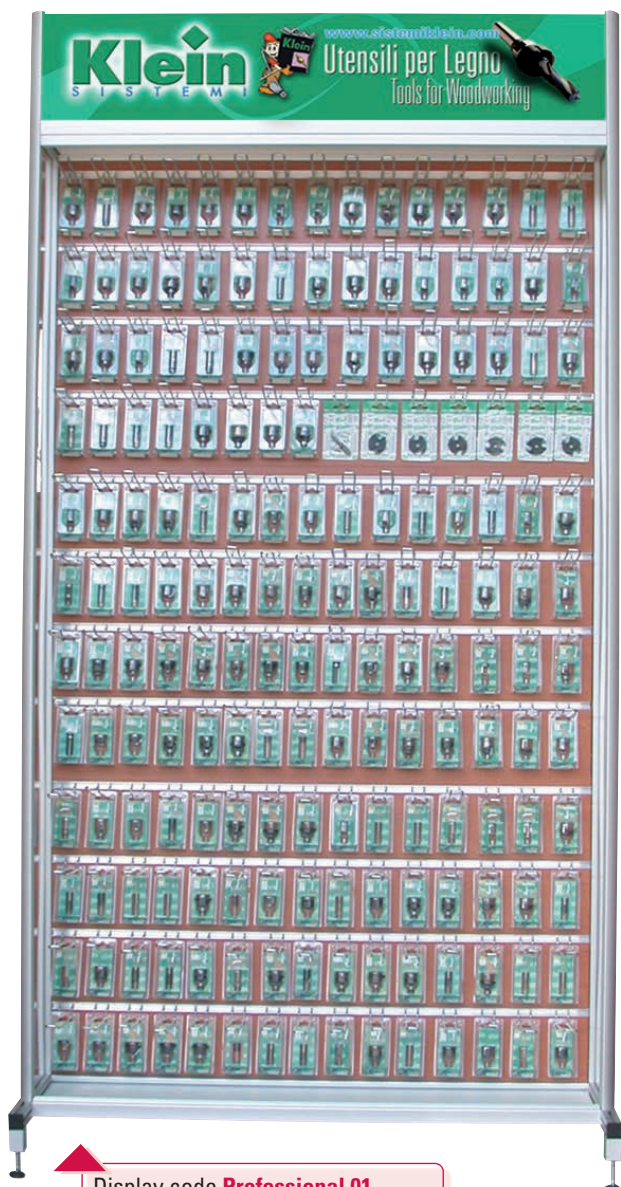

Display code **Professional 01**
includes:
Router bits for portable routers
S= 6/8 - 180 positions

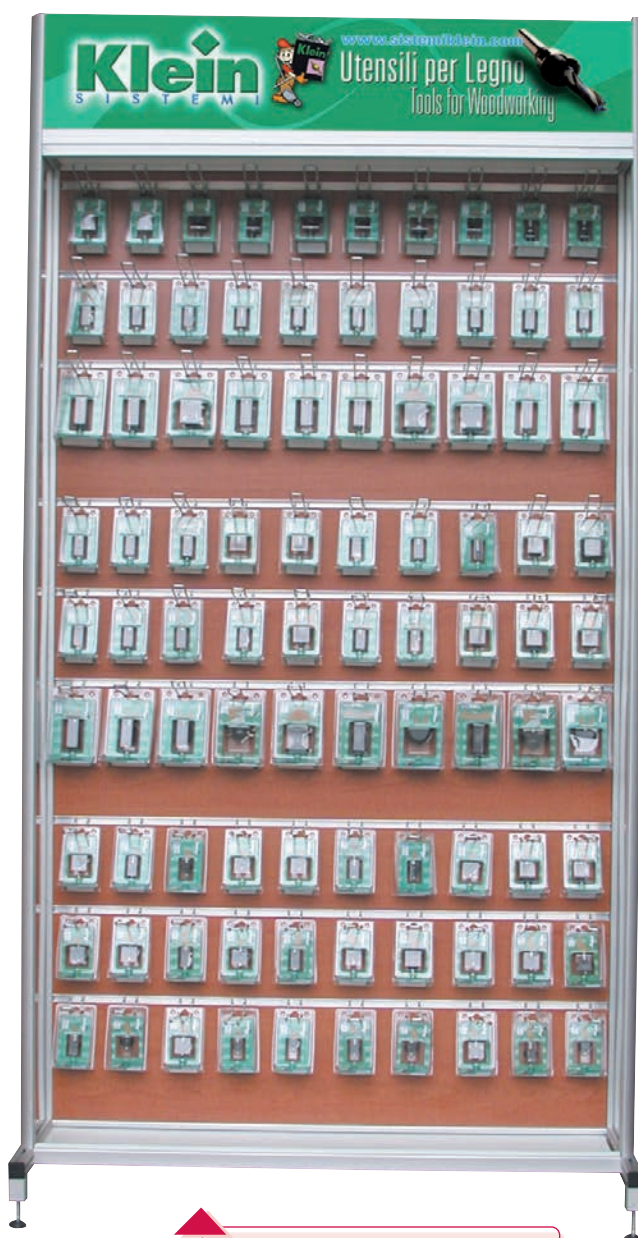

Display code **Professional 02**
includes:
Router bits for portable routers
S= 12 - 90 positions

Router bits for hand portable machines

S=Ø10 - S=Ø12 - S=Ø12,7 (1/2")



2



HW STRAIGHT BITS S=10 Z=2+1
Page 2.05



HW STRAIGHT BITS S=10
LONG TYPE Z=2+1
Page 2.05



HW STRAIGHT BITS S=12 Z=2+1
Page 2.05



HW STRAIGHT BITS Z=2
Page 2.05



HW STRAIGHT BITS Z=2 LONG TYPE
Page 2.06

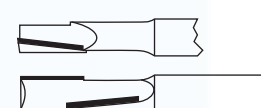

HW STAGGER BITS Z=2
Page 2.06



HW PANEL PILOT BITS Z=1+1
Page 2.06



HW PLUNGE TYPE OGEE BITS Z=2
Page 2.06

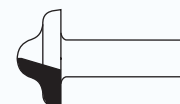

HW PLUNGE TYPE OGEE BITS Z=2
Page 2.06

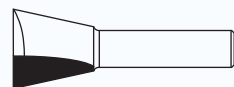

HW DOVETAIL BITS Z=2
Page 2.06

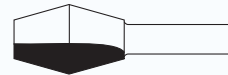

HW 14° BUTTERFLY SPLINE BITS Z=2
Page 2.07



HW V-GROOVE BITS Z=2
Page 2.07



HW CORE BOX BITS Z=2
Page 2.07

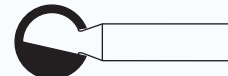

HW BALL AND PLUNGE BITS Z=2
Page 2.07

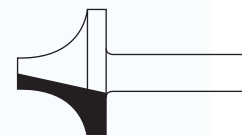

HW PLUNGING ROUND-OVER
BITS Z=2
Page 2.07

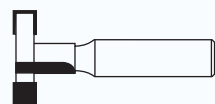

HW T-SLOT ROUTER BITS Z=2
Page 2.07

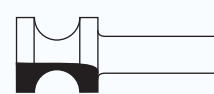

HW BULL NOSE RADIUS BITS Z=2
Page 2.08

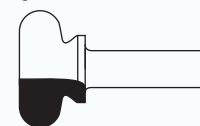

HW FINGER GRIP BITS Z=2
Page 2.08

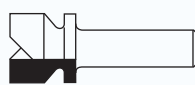

HW FINGER GRIP BITS Z=2
Page 2.08

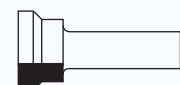

HW DRAWER LOCK BITS Z=2
Page 2.08

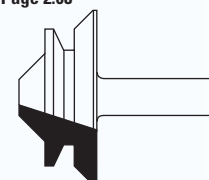

HW 45° LOCK MITRE BITS Z=2
Page 2.08

Klein®

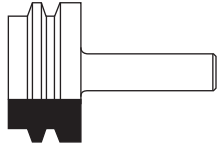

HW GLUE JOINT BITS Z=2
Page 2.08

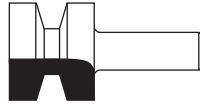

HW WEDGE TONGUE
AND GROOVE BITS Z=2
Page 2.09



HW PROFILE BITS Z=2
Page 2.09



HW CROWN MOULDING BITS Z=2
Page 2.09



HW CROWN MOULDING BITS Z=2
Page 2.09



HW CROWN MOULDING BITS Z=2
Page 2.09

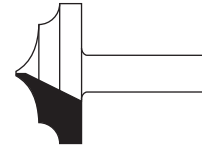

HW PROFILE BITS Z=2
Page 2.09



HW PROFILE BITS Z=2
Page 2.09

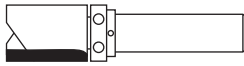

HW FLUSH TRIM BITS WITH
UPPER BALL BEARING GUIDE Z=2
Page 2.10

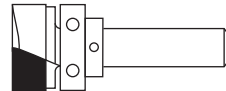

HW PLUNGE BITS WITH
UPPER BALL BEARING GUIDE Z=2
Page 2.10

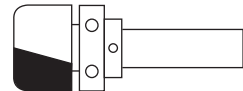

HW BOWL AND TRAY BITS WITH
UPPER BALL BEARING GUIDE Z=2
Page 2.10

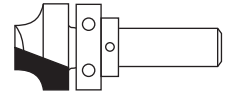

HW BEADING BITS WITH
UPPER BALL BEARING GUIDE Z=2
Page 2.10

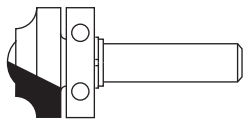

HW CLASSICAL PLUNGE BITS WITH
UPPER BALL BEARING GUIDE Z=2
Page 2.10

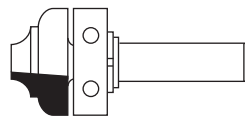

HW CLASSICAL PLUNGE BITS WITH
UPPER BALL BEARING GUIDE Z=2
Page 2.11

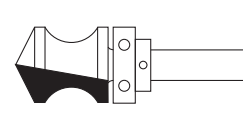

HW HAND GRIP PLUNGE BITS WITH
UPPER BALL BEARING GUIDE Z=2
Page 2.11



HW WINDOW SILL EDGE BITS Z=2
Page 2.11



HW RAISED PANEL BITS Z=2
Page 2.11



HW DOUBLE RADIUS BITS Z=2
Page 2.11



HW COVE BITS Z=2
Page 2.11



HW FLAT SUNK BEAD BITS Z=2
Page 2.12



HW SUNK BEAD BITS Z=2
Page 2.12

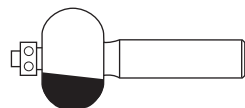

HW SUNK BEAD BITS Z=2
Page 2.12



HW FLAT ROUNDING-OVER BITS Z=2
Page 2.12

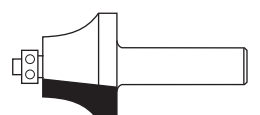

HW SUNK BEAD BITS Z=2
Page 2.12



HW FLUSH TRIM BITS WITH
BALL BEARING GUIDE Z=2
Page 2.12



HW COVE BITS WITH
BALL BEARING GUIDE
Page 2.13



HW ROMAN OGEE BITS WITH
BALL BEARING GUIDE Z=2
Page 2.13

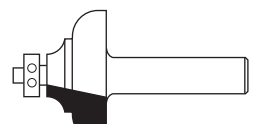

HW CLASSICAL OGEE BITS WITH
BALL BEARING GUIDE Z=2
Page 2.13



HW RABBETING BITS WITH BALL BEARING GUIDE Z=2
Page 2.13

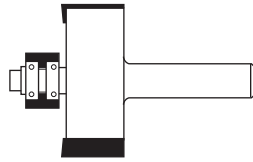

HW RABBETING BITS WITH BALL BEARING GUIDE Z=2
Page 2.14

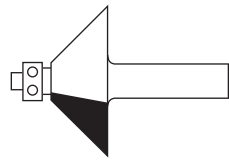

HW BEVEL TRIM BITS WITH BALL BEARING GUIDE Z=2
Page 2.14

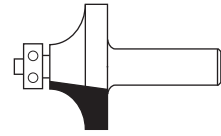

HW CORNER ROUNDING BITS WITH BALL BEARING GUIDE Z=2
Page 2.14

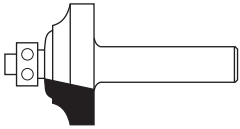

HW CLASSICAL BITS WITH BALL BEARING GUIDE Z=2
Page 2.14

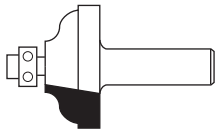

HW OGEE BITS WITH BALL BEARING GUIDE Z=2
Page 2.15

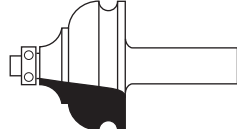

HW MOULDING BITS WITH BALL BEARING GUIDE Z=2
Page 2.15

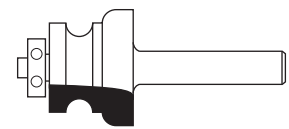

HW MOULDING BITS WITH BALL BEARING GUIDE Z=2
Page 2.15

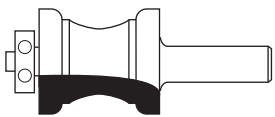

HW MOULDING BITS WITH BALL BEARING GUIDE Z=2
Page 2.15



HW DRAWING LINE BITS WITH BALL BEARING GUIDE Z=2
Page 2.15



HW DRAWING LINE BITS WITH BALL BEARING GUIDE Z=2
Page 2.15



HW DRAWING LINE BITS WITH BALL BEARING GUIDE Z=2
Page 2.16



HW ARCHITECTURAL MOULDING LINE BITS WITH BALL BEARING GUIDE Z=2
Page 2.16



HW ARCHITECTURAL MOULDING LINE BITS WITH BALL BEARING GUIDE Z=2
Page 2.16

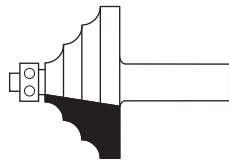

HW MULTI RADIUS BITS Z=2
Page 2.16

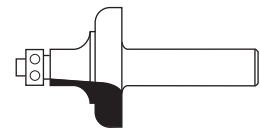

HW MULTIPLE PROFILE BITS Z=2
Page 2.16

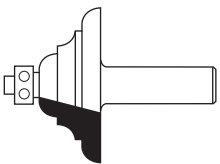

HW MULTIPLE PROFILE BITS Z=2
Page 2.17

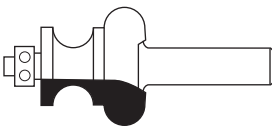

HW MULTIPLE PROFILE BITS Z=2
Page 2.17



HW CLASSICAL MULTI-FORM BITS WITH BALL BEARING GUIDE Z=2
Page 2.17

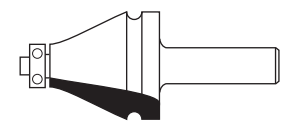

HW HANDRAIL BITS WITH BALL BEARING GUIDE Z=2
Page 2.17

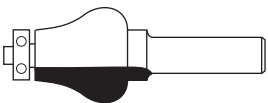

HW HANDRAIL BITS WITH BALL BEARING GUIDE Z=2
Page 2.18



HW EDGE BEADING BITS Z=2
Page 2.18

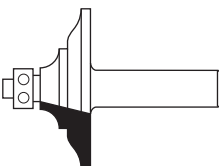

HW HANDRAIL AND TABLE EDGE BITS Z=2
Page 2.18

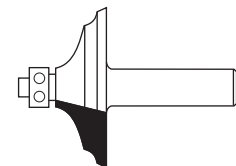

HW HANDRAIL AND TABLE EDGE BITS Z=2
Page 2.18

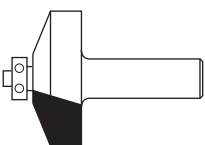

HW RAISED PANEL BITS WITH BALL BEARING GUIDE Z=2
Page 2.18

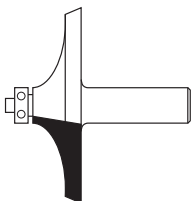

HW HANDRAIL-TABLE EDGE BITS WITH BALL BEARING GUIDE Z=2
Page 2.18

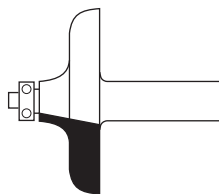

HW HANDRAIL-TABLE EDGE BITS WITH BALL BEARING GUIDE Z=2
Page 2.19

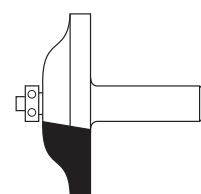

HW RAISED PANEL BITS WITH BALL BEARING GUIDE Z=2
Page 2.19

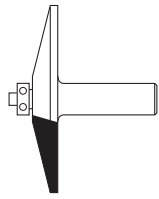

HW RAISED PANEL BITS WITH BALL BEARING GUIDE Z=2
Page 2.19

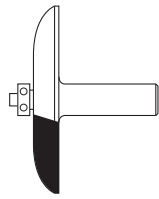

HW RAISED PANEL BITS WITH BALL BEARING GUIDE Z=2
Page 2.19

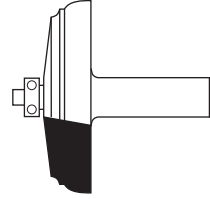

HW RAISED PANEL BITS WITH BALL BEARING GUIDE Z=2
Page 2.19

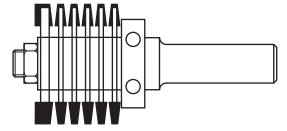

HW FINGER JOINT ASSEMBLY WITH BALL BEARING GUIDE Z=2
Page 2.20

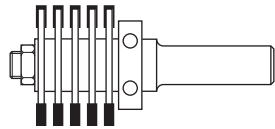

HW FINGER JOINT ASSEMBLY WITH BALL BEARING GUIDE Z=3
Page 2.20

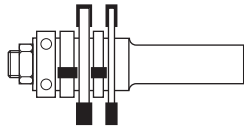

HW SLOT CUTTER SET WITH BALL BEARING GUIDE Z=2
Page 2.21

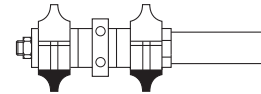

HW DOUBLE CORNER ROUND ASSEMBLY WITH BALL BEARING GUIDE Z=3
Page 2.21

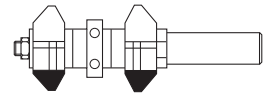

HW DOUBLE CHAMFER ASSEMBLY WITH BALL BEARING GUIDE Z=3
Page 2.22

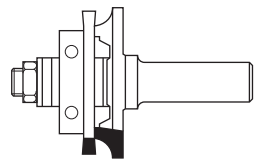

HW BEAD PANELING ASSEMBLY WITH BALL BEARING GUIDE Z=2
Page 2.22

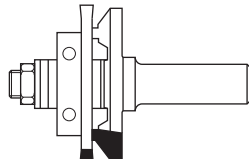

HW V PANELING ASSEMBLY WITH BALL BEARING GUIDE Z=2
Page 2.23

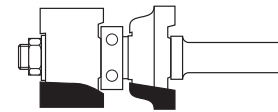

HW OGEE WINDOW SASH ASSEMBLY WITH BALL BEARING GUIDE Z=2
Page 2.23

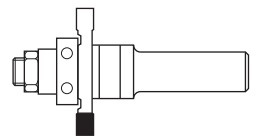

HW TONGUE AND GROOVE ASSEMBLY WITH BALL BEARING GUIDE Z=2
Page 2.24

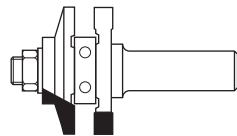

HW STILE AND RAIL ASSEMBLY WITH BALL BEARING GUIDE Z=2
Page 2.24

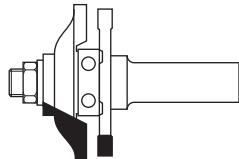

HW STILE AND RAIL ASSEMBLY WITH BALL BEARING GUIDE Z=2
Page 2.25

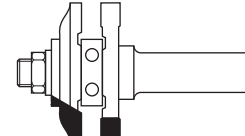

HW STILE AND RAIL ASSEMBLY WITH BALL BEARING GUIDE Z=2
Page 2.25

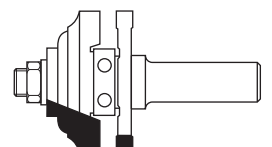

HW STILE AND RAIL ASSEMBLY WITH BALL BEARING GUIDE Z=2
Page 2.26

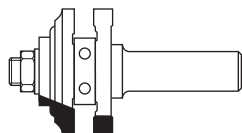

HW STILE AND RAIL ASSEMBLY WITH BALL BEARING GUIDE Z=2
Page 2.26



HW BEADING BITS FOR RADIUS WINDOW Z=2
Page 2.27



2 PIECE SET FOR CABINET DOORS MAKER "TYPE 1"
Page 2.28



2 PIECE SET FOR CABINET DOORS MAKER "TYPE 2"
Page 2.28



2 PIECE SET FOR CABINET DOORS MAKER "TYPE 3"
Page 2.29



3 PIECE SET FOR CABINET DOORS MAKER AND JOINTS "TYPE 1"
Page 2.29



3 PIECE SET FOR CABINET DOORS MAKER AND JOINTS "TYPE 2"
Page 2.30



3 PIECE SET FOR CABINET DOORS MAKER AND JOINTS "TYPE 3"
Page 2.30



DISPLAY UNITS
Page 2.31

HW STRAIGHT BITS S=10 Z=2+1

ART. D101

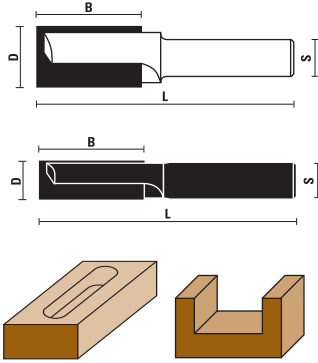

- Straight cut Z=2+1, plunging
- To be used also for working plastic materials, acrylic, polypropylene, HDPE, acetates and polycarbonates
- Also for C.N.C. machines

| S Ø 10 | D | B | L |
|--------------|----|----|----|
| D101.040.R ▲ | 4 | 13 | 49 |
| D101.050.R ▲ | 5 | 15 | 49 |
| D101.060.R ▲ | 6 | 16 | 53 |
| D101.070.R ▲ | 7 | 20 | 55 |
| D101.080.R ▲ | 8 | 23 | 60 |
| D101.090.R ▲ | 9 | 23 | 60 |
| D101.100.R ▲ | 10 | 23 | 70 |
| D101.120.R | 12 | 23 | 70 |
| D101.140.R | 14 | 23 | 70 |
| D101.150.R | 15 | 23 | 70 |
| D101.160.R | 16 | 23 | 70 |
| D101.180.R | 18 | 23 | 70 |
| D101.200.R | 20 | 23 | 70 |
| D101.220.R | 22 | 23 | 70 |
| D101.240.R | 24 | 23 | 70 |

▲ Solid carbide

HW STRAIGHT BITS S=10 LONG TYPE Z=2+1

ART. D102

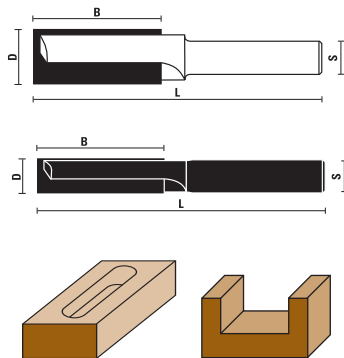

- Straight cut Z=2+1, plunging
- To be used also for working plastic materials, acrylic, polypropylene, HDPE, acetates and polycarbonates
- Also for C.N.C. machines

| S Ø 10 | D | B | L |
|--------------|----|----|----|
| D102.100.R ▲ | 10 | 40 | 87 |
| D102.120.R | 12 | 40 | 87 |
| D102.140.R | 14 | 40 | 87 |
| D102.160.R | 16 | 45 | 87 |
| D102.180.R | 18 | 45 | 87 |
| D102.200.R | 20 | 45 | 87 |

▲ Solid carbide

HW STRAIGHT BITS S=12 Z=2+1

ART. D103

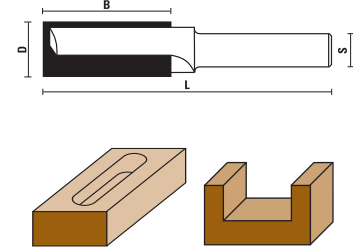

- Straight cut Z=2+1, plunging
- To be used also for working plastic materials, acrylic, polypropylene, HDPE, acetates and polycarbonates
- Also for C.N.C. machines

| S Ø 12 | D | B | L |
|------------|----|----|-----|
| D103.100.R | 10 | 35 | 90 |
| D103.120.R | 12 | 35 | 90 |
| D103.121.R | 12 | 45 | 90 |
| D103.140.R | 14 | 35 | 90 |
| D103.141.R | 14 | 50 | 100 |
| D103.160.R | 16 | 35 | 90 |
| D103.161.R | 16 | 50 | 100 |
| D103.180.R | 18 | 35 | 90 |
| D103.181.R | 18 | 50 | 100 |
| D103.200.R | 20 | 35 | 90 |
| D103.201.R | 20 | 50 | 100 |
| D103.220.R | 22 | 35 | 90 |
| D103.240.R | 24 | 35 | 90 |

HW STRAIGHT BITS Z=2

ART. E101 - G101

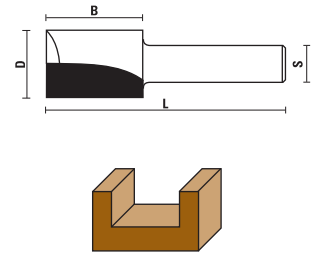

| S Ø 12 | S Ø 12,7 (1/2") | D | B | L |
|------------|-----------------|------|----|----|
| E101.040.R | | 4 | 11 | 63 |
| E101.050.R | | 5 | 11 | 60 |
| E101.060.R | G101.060.R | 6 | 19 | 63 |
| | G101.064.R | 6,4 | 19 | 63 |
| E101.070.R | | 7 | 19 | 63 |
| E101.080.R | G101.080.R | 8 | 19 | 63 |
| | G101.095.R | 9,5 | 25 | 70 |
| E101.100.R | G101.100.R | 10 | 25 | 70 |
| E101.120.R | | 12 | 25 | 70 |
| | G101.127.R | 12,7 | 25 | 66 |
| E101.140.R | | 14 | 32 | 73 |
| | G101.143.R | 14,3 | 32 | 73 |
| E101.150.R | | 15 | 25 | 66 |
| E101.160.R | G101.160.R | 16 | 32 | 73 |
| E101.170.R | | 17 | 32 | 73 |
| E101.180.R | | 18 | 32 | 73 |
| E101.190.R | | 19 | 32 | 73 |
| E101.200.R | | 20 | 32 | 73 |
| E101.220.R | | 22 | 32 | 73 |
| E101.250.R | | 25 | 32 | 73 |
| | G101.254.R | 25,4 | 32 | 73 |
| E101.300.R | | 30 | 32 | 73 |
| E101.350.R | | 35 | 32 | 73 |
| E101.400.R | | 40 | 32 | 73 |



HW STRAIGHT BITS Z=2 LONG TYPE

ART. E102 - G102 / E103 - G103

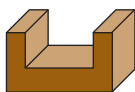
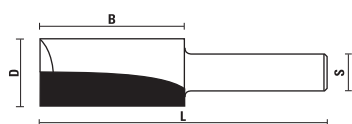

| S Ø 12 | S Ø 12,7 (1/2") | D | B | L |
|------------|-----------------|------|----|-----|
| E102.080.R | | 8 | 25 | 70 |
| | G102.095.R | 9,5 | 32 | 76 |
| E102.100.R | G102.100.R | 10 | 32 | 76 |
| E102.120.R | G102.120.R | 12 | 38 | 80 |
| | G102.127.R | 12,7 | 38 | 80 |
| E102.160.R | G102.160.R | 16 | 38 | 80 |
| E102.190.R | G102.190.R | 19 | 38 | 80 |
| <hr/> | | | | |
| E103.120.R | G103.120.R | 12 | 50 | 108 |
| | G103.127.R | 12,7 | 50 | 108 |
| E103.180.R | | 18 | 50 | 92 |
| E103.200.R | | 20 | 50 | 92 |
| E103.220.R | | 22 | 50 | 92 |

HW STAGGER BITS Z=2

ART. E104 - G104

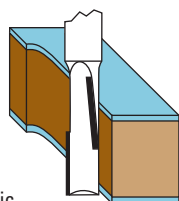
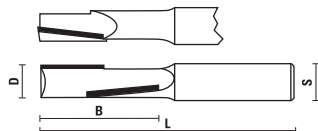

- Excellent for working laminated, panel, melaminic, veneered and plywood
- Good finishing top/bottom

| S Ø 12 | S Ø 12,7 (1/2") | D | B | L |
|------------|-----------------|------|----|-----|
| E104.127.R | G104.127.R | 12,7 | 38 | 79 |
| E104.128.R | G104.128.R | 12,7 | 54 | 108 |

HW PANEL PILOT BITS Z=1+1

ART. E105 - G105

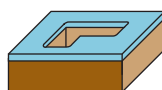
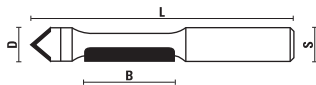

| S Ø 12 | S Ø 12,7 (1/2") | D | B | L |
|------------|-----------------|------|----|----|
| E105.127.R | G105.127.R | 12,7 | 30 | 90 |

HW PLUNGE TYPE OGEE BITS Z=2

ART. E106 - G106

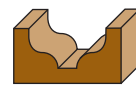
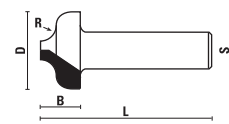

| S Ø 12 | S Ø 12,7 (1/2") | D | R | B | L |
|------------|-----------------|------|-----|-----|----|
| E106.190.R | G106.190.R | 19 | 3,5 | 13 | 68 |
| E106.254.R | G106.254.R | 25,4 | 3,2 | 9,5 | 50 |
| E106.350.R | G106.350.R | 35 | 3,2 | 9,5 | 59 |

HW PLUNGE TYPE OGEE BITS Z=2

ART. E107 - G107

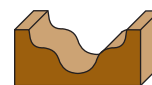
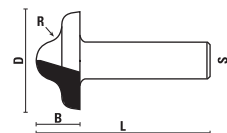

| S Ø 12 | S Ø 12,7 (1/2") | D | R | B | L |
|------------|-----------------|----|---|----|----|
| E107.270.R | G107.270.R | 27 | 6 | 12 | 57 |

HW DOVETAIL BITS Z=2

ART. E108 - G108

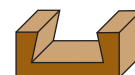
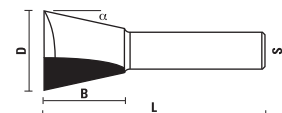

| S Ø 12 | S Ø 12,7 (1/2") | D | α | B | L |
|------------|-----------------|------|-----|------|----|
| E108.161.R | G108.161.R | 16 | 7° | 22 | 65 |
| E108.190.R | G108.190.R | 19 | 14° | 19 | 65 |
| E108.191.R | G108.191.R | 19 | 7° | 22 | 65 |
| E108.220.R | G108.220.R | 22 | 14° | 22 | 67 |
| E108.221.R | G108.221.R | 22 | 7° | 22 | 60 |
| E108.254.R | G108.254.R | 25,4 | 14° | 25,4 | 70 |

HW 14° BUTTERFLY SPLINE BITS Z=2

ART. E109 - G109

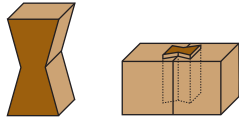
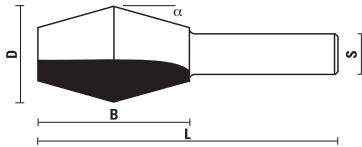

| S Ø 12 | S Ø 12,7 (1/2") | D | α | B | L |
|------------|-----------------|----|-----|----|----|
| E109.280.R | G109.280.R | 28 | 14° | 46 | 84 |

HW V-GROOVE BITS Z=2

ART. E110 - G110

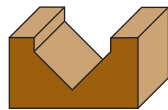
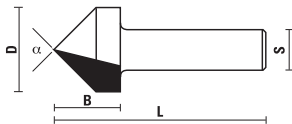
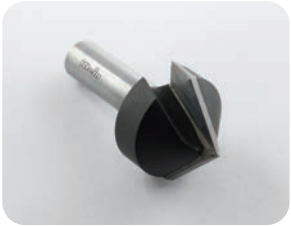

| S Ø 12 | S Ø 12,7 (1/2") | D | α | B | L |
|------------|-----------------|------|-----|----|----|
| E110.127.R | G110.127.R | 12,7 | 90° | 13 | 54 |
| E110.160.R | G110.160.R | 16 | 90° | 13 | 51 |
| E110.190.R | G110.190.R | 19 | 90° | 16 | 54 |
| E110.254.R | G110.254.R | 25,4 | 90° | 19 | 57 |
| E110.320.R | G110.320.R | 32 | 90° | 25 | 64 |
| E110.381.R | G110.381.R | 38,1 | 90° | 32 | 70 |
| E110.501.R | G110.501.R | 51 | 90° | 44 | 83 |

HW CORE BOX BITS Z=2

ART. E111 - G111

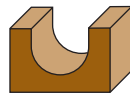
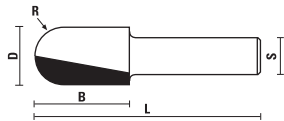

| S Ø 12 | S Ø 12,7 (1/2") | D | R | B | L |
|------------|-----------------|------|------|----|----|
| E111.127.R | G111.127.R | 12,7 | 6,4 | 32 | 73 |
| E111.160.R | G111.160.R | 16 | 8 | 32 | 70 |
| E111.190.R | G111.190.R | 19 | 9,5 | 32 | 70 |
| E111.220.R | G111.220.R | 22 | 11 | 32 | 70 |
| E111.254.R | G111.254.R | 25,4 | 12,7 | 32 | 70 |
| E111.317.R | G111.317.R | 32 | 16 | 32 | 70 |
| E111.380.R | G111.380.R | 38 | 19 | 32 | 70 |
| E111.500.R | G111.500.R | 50 | 25 | 32 | 70 |

HW BALL AND PLUNGE BITS Z=2

ART. E112 - G112

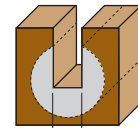
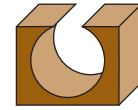
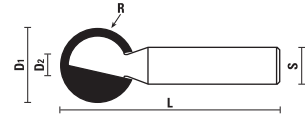

min 13



These tools can produce grooves for sliding panels or electrical wires, after a first groove which allows the tool shank moving

| S Ø 12 | S Ø 12,7 (1/2") | D1 | D2 | R | L |
|-------------|-----------------|------|------|------|----|
| E112.127.R | G112.127.R | 12,7 | 6,5 | 6,4 | 57 |
| E112.160.R | G112.160.R | 16 | 7,5 | 8 | 60 |
| E112.190.R | G112.190.R | 19 | 8,5 | 9,5 | 64 |
| E112.254.R | G112.254.R | 25,4 | 9 | 12,7 | 70 |
| E112.286.R* | | 28,6 | 10,3 | 14,3 | 70 |
| E112.320.R | G112.320.R | 32 | 12,7 | 16 | 73 |

* Selling out

HW PLUNGING ROUND-OVER BITS Z=2

ART. E113 - G113

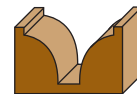
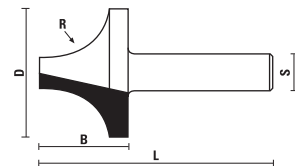

| S Ø 12 | S Ø 12,7 (1/2") | D | R | B | L |
|------------|-----------------|------|------|------|------|
| E113.160.R | G113.160.R | 16 | 5 | 11 | 49 |
| E113.190.R | G113.190.R | 19 | 6,4 | 13 | 51 |
| E113.220.R | G113.220.R | 22 | 8 | 14 | 52 |
| E113.254.R | G113.254.R | 25,4 | 9,5 | 16 | 54 |
| E113.349.R | G113.349.R | 34,9 | 12,7 | 25,4 | 63,5 |
| E113.445.R | G113.445.R | 44,5 | 16 | 31,8 | 70 |
| E113.510.R | G113.510.R | 51 | 19 | 36 | 75 |

HW T-SLOT ROUTER BITS Z=2

ART. E114 - G114

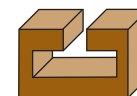
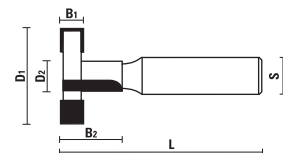

| S Ø 12 | S Ø 12,7 (1/2") | D1 | D2 | B1 | B2 | L |
|------------|-----------------|----|-----|-----|----|----|
| E114.280.R | G114.280.R | 28 | 9,5 | 8 | 21 | 65 |
| E114.350.R | G114.350.R | 35 | 13 | 9,5 | 22 | 65 |

HW BULL NOSE RADIUS BITS Z=2

ART. E115 - G115

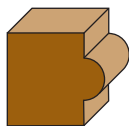
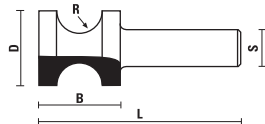

| S Ø 12 | S Ø 12,7 (1/2") | D | R | B | L |
|------------|-----------------------------|------|------|----|----|
| E115.220.R | G115.220.R | 22 | 5 | 19 | 57 |
| E115.260.R | G115.260.R | 26 | 6,8 | 25 | 63 |
| E115.280.R | G115.280.R | 28 | 8 | 25 | 64 |
| E115.333.R | G115.333.R | 33,3 | 9,5 | 35 | 73 |
| E115.429.R | G115.429.R | 42,9 | 12,7 | 40 | 78 |
| E115.510.R | G115.510.R | 51 | 16 | 50 | 88 |
| E115.600.R | G115.600.R - max RPM 18.000 | 60 | 19 | 50 | 88 |

HW DRAWER LOCK BITS Z=2

ART. E119 - G119

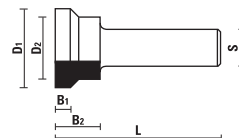

| S Ø 12 | S Ø 12,7 (1/2") | D1 | D2 | B1 | B2 | L |
|------------|-----------------|------|------|----|----|----|
| E119.254.R | G119.254.R | 25,4 | 18,5 | 4 | 13 | 49 |

HW FINGER GRIP BITS Z=2

ART. E116 - G116

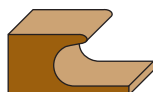
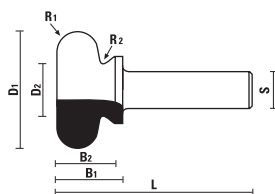

| S Ø 12 | S Ø 12,7 (1/2") | D1 | D2 | R1 | R2 | B1 | B2 | L |
|------------|-----------------|------|----|-----|-----|----|----|----|
| E116.190.R | G116.190.R | 19 | 10 | 4,8 | 2,5 | 19 | 14 | 57 |
| E116.381.R | G116.381.R | 38,1 | 17 | 6 | 2 | 21 | 18 | 59 |
| E116.445.R | G116.445.R | 44,5 | 17 | 8 | 2 | 25 | 22 | 63 |

HW 45° LOCK MITER BITS Z=2

ART. E120 - G120

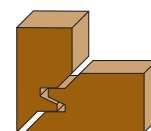
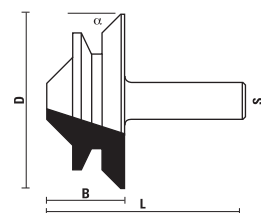
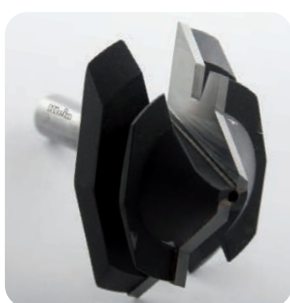

| S Ø 12 | S Ø 12,7 (1/2") | D | α | B | L |
|------------|-----------------------------|------|-----|------|----|
| E120.445.R | G120.445.R | 44,5 | 45° | 20 | 58 |
| E120.680.R | G120.680.R - max RPM 18.000 | 68 | 45° | 29,5 | 68 |

HW FINGER GRIP BITS Z=2

ART. E118 - G118

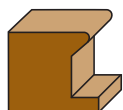
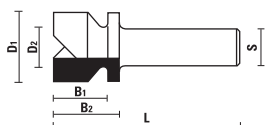

| S Ø 12 | S Ø 12,7 (1/2") | D1 | D2 | B1 | B2 | L |
|------------|-----------------|----|----|----|----|----|
| E118.220.R | G118.220.R | 22 | 13 | 17 | 21 | 59 |

HW GLUE JOINT BITS Z=2

ART. E121 - G121

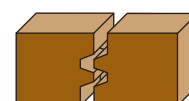
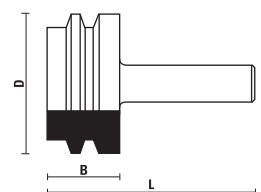

| S Ø 12 | S Ø 12,7 (1/2") | D | B | L |
|------------|-----------------|----|----|----|
| E121.470.R | G121.470.R | 47 | 28 | 66 |

HW WEDGE TONGUE AND GROOVE BITS Z=2

ART. E122 - G122 / E123 - G123

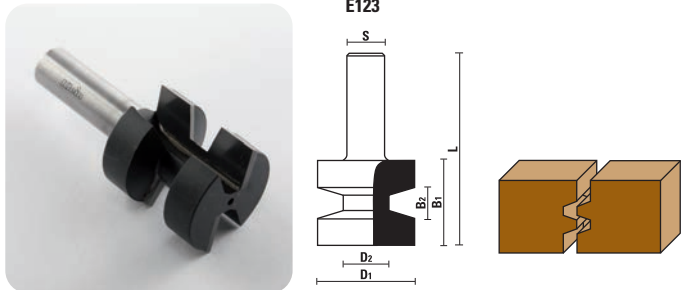
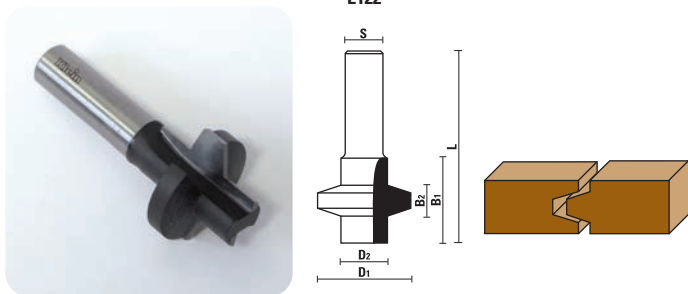

| S Ø 12 | S Ø 12,7 (1/2") | D1 | D2 | α | B1 | B2 | L |
|------------|-----------------|----|----|-----|----|----|----|
| E122.320.R | G122.320.R | 32 | 14 | 15° | 32 | 11 | 70 |
| E123.320.R | G123.320.R | 32 | 14 | 15° | 32 | 11 | 70 |

HW PROFILE BITS Z=2

ART. E124 - G124

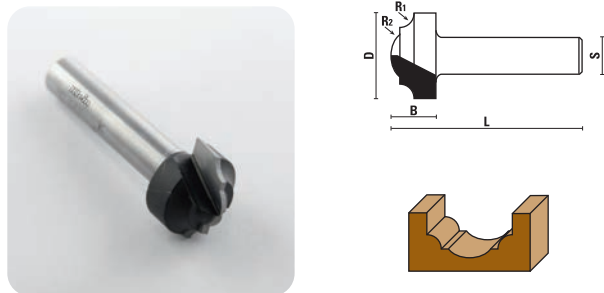

| S Ø 12 | S Ø 12,7 (1/2") | D | R1 | R2 | B | L |
|------------|-----------------|------|-----|-----|------|----|
| E124.190.R | G124.190.R | 19 | 3,6 | 4 | 13 | 70 |
| E124.254.R | G124.254.R | 25,4 | 5 | 6,4 | 17,5 | 73 |

HW CROWN MOULDING BITS Z=2

ART. E125 - G125

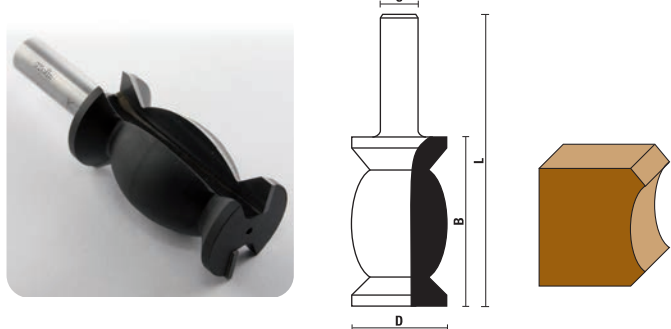

| S Ø 12 | S Ø 12,7 (1/2") | D | B | L |
|-------------|-----------------|----|----|----|
| E125.320.R* | G125.320.R* | 32 | 58 | 96 |

* Selling out

HW CROWN MOULDING BITS Z=2

ART. E126

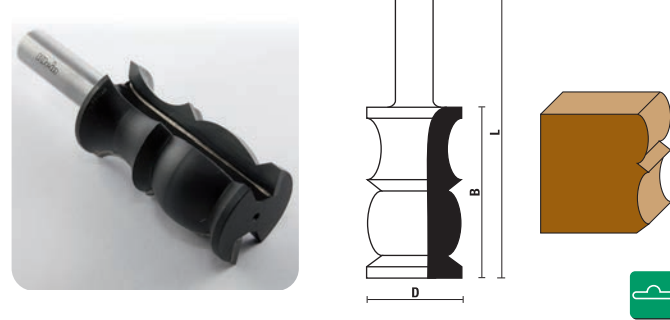

| S Ø 12 | D | B | L |
|-------------|----|----|----|
| E126.320.R* | 32 | 58 | 96 |

* Selling out

HW CROWN MOULDING BITS Z=2

ART. E127 - G127

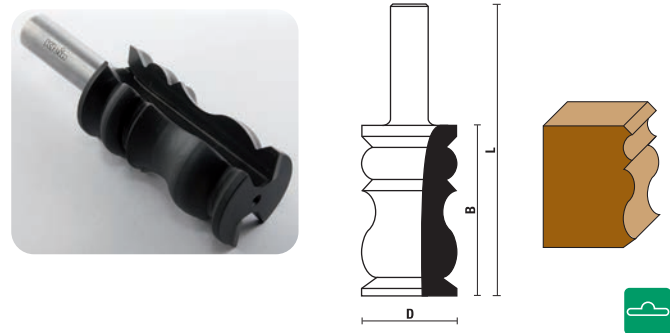

| S Ø 12 | S Ø 12,7 (1/2") | D | B | L |
|------------|-----------------|----|----|----|
| E127.320.R | G127.320.R | 32 | 58 | 96 |

HW PROFILE BITS Z=2

ART. E128 - G128

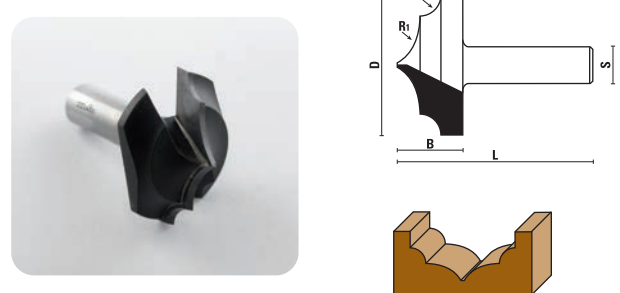

For producing ornaments

| S Ø 12 | S Ø 12,7 (1/2") | D | R1 | R2 | B | L |
|------------|-----------------|----|-----|----|----|----|
| E128.410.R | G128.410.R | 41 | 6,4 | 15 | 18 | 56 |

HW PROFILE BITS Z=2

ART. E129 - G129

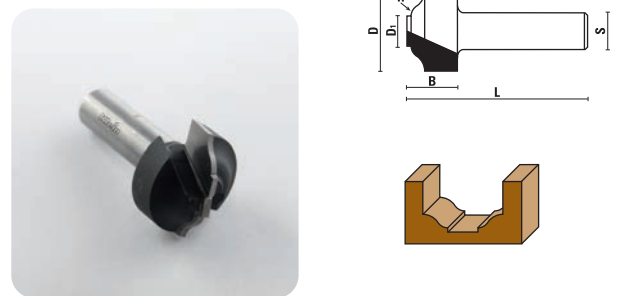

| S Ø 12 | S Ø 12,7 (1/2") | D | D1 | R | B | L |
|------------|-----------------|------|-----|-----|----|----|
| E129.254.R | G129.254.R | 25,4 | 9,5 | 4,8 | 15 | 53 |
| E129.300.R | G129.300.R | 30 | 12 | 6 | 15 | 53 |

HW FLUSH TRIM BITS WITH UPPER BALL BEARING GUIDE Z=2

ART. E130 - G130

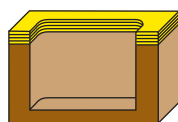
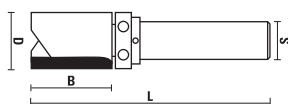

| S Ø 12 | S Ø 12,7 (1/2") | D | B | L |
|------------|-----------------|----|------|----|
| E130.190.R | G130.190.R | 19 | 25,4 | 77 |
| E130.191.R | G130.191.R | 19 | 51 | 92 |



Z050.012.N



Z058.002.N



Z051.005.N

| S Ø 12 | S Ø 12,7 (1/2") | D | B | L |
|------------|-----------------|------|----|----|
| E130.254.R | G130.254.R | 25,4 | 45 | 95 |



Z050.009.N



Z058.002.N



Z051.005.N

HW PLUNGE BITS WITH UPPER BALL BEARING GUIDE Z=2

ART. E131 - G131

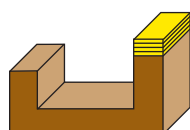
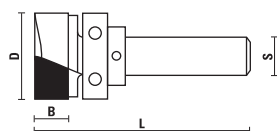

| S Ø 12 | S Ø 12,7 (1/2") | D | B | L |
|------------|-----------------|----|----|----|
| E131.190.R | G131.190.R | 19 | 11 | 64 |



Z050.012.N



Z058.002.N



Z051.005.N

| S Ø 12 | S Ø 12,7 (1/2") | D | B | L |
|------------|-----------------|------|----|----|
| E131.254.R | G131.254.R | 25,4 | 11 | 64 |



Z050.009.N



Z058.002.N



Z051.005.N

| S Ø 12 | S Ø 12,7 (1/2") | D | B | L |
|------------|-----------------|----|----|----|
| E131.380.R | G131.380.R | 38 | 16 | 69 |



Z050.013.N



Z058.003.N



Z051.005.N

HW BOWL AND TRAY BITS WITH UPPER BALL BEARING GUIDE Z=2

ART. E132 - G132

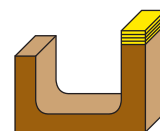
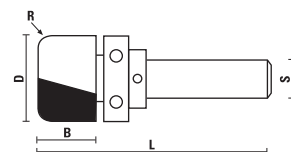

| S Ø 12 | S Ø 12,7 (1/2") | D | R | B | L |
|------------|-----------------|----|-----|----|----|
| E132.190.R | G132.190.R | 19 | 6,4 | 16 | 67 |



Z050.012.N



Z058.002.N



Z051.005.N

| S Ø 12 | S Ø 12,7 (1/2") | D | R | B | L |
|------------|-----------------|------|-----|----|----|
| E132.286.R | G132.286.R | 28,6 | 6,4 | 16 | 67 |



Z050.015.N



Z058.003.N



Z051.005.N

HW BEADING BITS WITH UPPER BALL BEARING GUIDE Z=2

ART. E133

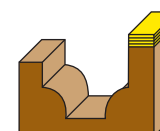
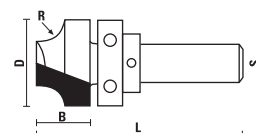

| S Ø 12 | D | R | B | L |
|-------------|------|---|----|----|
| E133.286.R* | 28,6 | 8 | 15 | 58 |

* Selling out



Z050.015.N



Z058.003.N



Z051.005.N

HW CLASSICAL PLUNGE BITS WITH UPPER BALL BEARING GUIDE Z=2

ART. E134 - G134

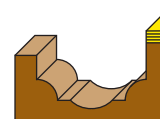
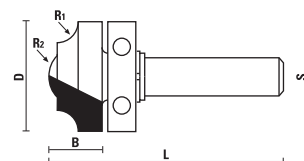

For producing ornaments

| S Ø 12 | S Ø 12,7 (1/2") | D | R1 | R2 | B | L |
|------------|-----------------|----|-----|----|----|----|
| E134.350.R | G134.350.R | 35 | 6,4 | 10 | 15 | 68 |



Z050.014.N



DIN 471-15

HW CLASSICAL PLUNGE BITS WITH UPPER BALL BEARING GUIDE Z=2

ART. E135 - G135

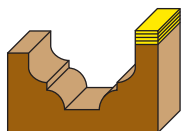
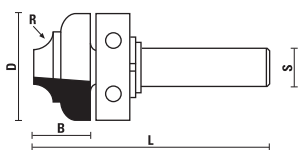

| S Ø 12 | S Ø 12,7 (1/2") | D | R | B | L |
|------------|-----------------|----|---|----|----|
| E135.350.R | G135.350.R | 35 | 5 | 14 | 67 |



Z050.014.N



DIN 471-15

HW HAND GRIP PLUNGE BITS WITH UPPER BALL BEARING GUIDE Z=2

ART. E136 - G136

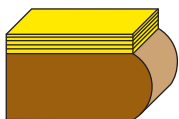
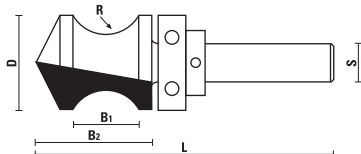

| S Ø 12 | S Ø 12,7 (1/2") | D | R | B1 | B2 | L |
|------------|-----------------|------|----|----|----|----|
| E136.286.R | G136.286.R | 28,6 | 13 | 22 | 40 | 92 |



Z050.015.N



Z058.003.N



Z051.005.N

HW WINDOW SILL EDGE BITS Z=2

ART. E137 - G137

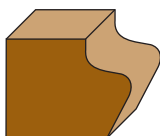
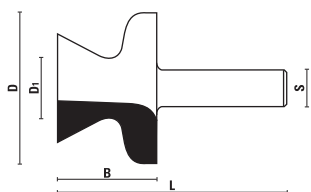

| S Ø 12 | S Ø 12,7 (1/2") | D | D1 | B | L |
|------------|-----------------|----|----|----|----|
| E137.510.R | G137.510.R | 51 | 19 | 32 | 70 |

HW RAISED PANEL BITS Z=2

ART. E138 - G138

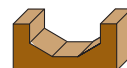
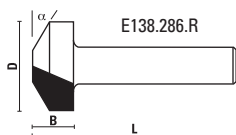
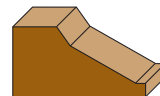
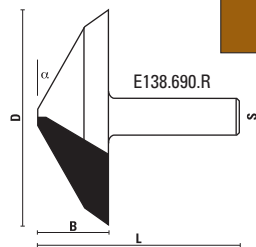

| S Ø 12 | S Ø 12,7 (1/2") | D | α | B | L |
|------------|-----------------------------|------|-----|----|----|
| E138.286.R | G138.286.R | 28,6 | 30° | 13 | 70 |
| E138.690.R | G138.690.R - max RPM 18.000 | 69 | 25° | 19 | 57 |

HW DOUBLE RADIUS BITS Z=2

ART. E139 - G139

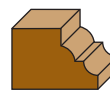
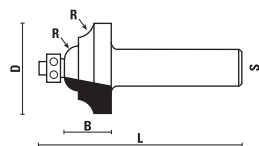

| S Ø 12 | S Ø 12,7 (1/2") | D | R | B | L |
|------------|-----------------|------|-----|----|----|
| E139.254.R | G139.254.R | 25,4 | 4 | 16 | 63 |
| E139.350.R | G139.350.R | 35 | 6,4 | 20 | 67 |



Z050.001.N



Z053.001.N



Z054.001.N



Z051.001.R

HW COVE BITS Z=2

ART. E140 - G140

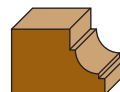
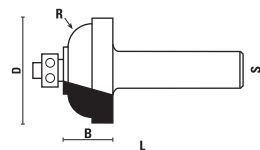

| S Ø 12 | S Ø 12,7 (1/2") | D | R | B | L |
|-------------|-----------------|------|-----|----|----|
| E140.286.R | G140.286.R | 28,6 | 4,8 | 13 | 61 |
| E140.350.R* | | 35 | 8 | 16 | 64 |

* Selling out



Z050.003.N



Z053.003.N



Z054.002.N



Z051.002.R

HW FLAT SUNK BEAD BITS Z=2

ART. E141 - G141

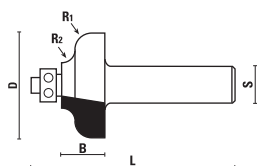

| S Ø 12 | S Ø 12,7 (1/2") | D | R1 | R2 | B | L |
|------------|-----------------|----|----|----|------|----|
| E141.350.R | G141.350.R | 35 | 6 | 5 | 17,5 | 65 |



Z050.002.N



Z053.002.N



Z054.002.N



Z051.002.R

HW SUNK BEAD BITS Z=2

ART. E142 - G142

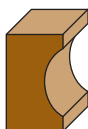
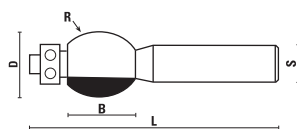

| S Ø 12 | S Ø 12,7 (1/2") | D | R | B | L |
|------------|-----------------|------|----|----|----|
| E142.190.R | G142.190.R | 19 | 8 | 13 | 70 |
| E142.220.R | G142.220.R | 22 | 12 | 19 | 78 |
| E142.254.R | G142.254.R | 25,4 | 32 | 38 | 98 |



Z050.003.N



Z053.003.N



Z054.002.N



Z051.002.R

HW SUNK BEAD BITS Z=2

ART. E143 - G143

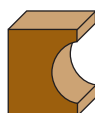
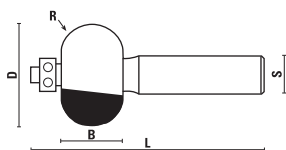

| S Ø 12 | S Ø 12,7 (1/2") | D | R | B | L |
|------------|-----------------|----|----|----|----|
| E143.330.R | G143.330.R | 33 | 10 | 20 | 75 |



Z050.003.N



Z053.003.N



Z054.002.N



Z051.002.R

HW FLAT ROUNDING-OVER BITS Z=2

ART. E144 - G144

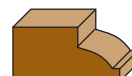
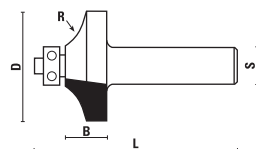

| S Ø 12 | S Ø 12,7 (1/2") | D | R | B | L |
|------------|-----------------|----|----|----|----|
| E144.300.R | G144.300.R | 30 | 12 | 10 | 57 |



Z050.003.N



Z053.003.N



Z054.002.N



Z051.002.R

HW SUNK BEAD BITS Z=2

ART. E145 - G145

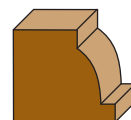
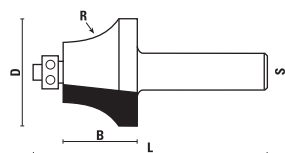

| S Ø 12 | S Ø 12,7 (1/2") | D | R | B | L |
|------------|-----------------|----|----|----|----|
| E145.270.R | G145.270.R | 27 | 17 | 17 | 67 |



Z050.003.N



Z053.003.N



Z054.002.N



Z051.002.R

HW FLUSH TRIM BITS WITH BALL BEARING GUIDE Z=2

ART. E146 - G146

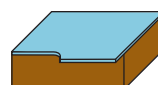
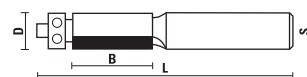

| S Ø 12 | S Ø 12,7 (1/2") | D | B | L |
|------------|-----------------|------|----|-----|
| E146.126.R | G146.126.R | 12,7 | 13 | 71 |
| E146.127.R | G146.127.R | 12,7 | 25 | 84 |
| E146.128.R | G146.128.R | 12,7 | 38 | 98 |
| E146.129.R | G146.129.R | 12,7 | 51 | 106 |



Z050.003.N



Z053.003.N



Z054.002.N



Z051.002.R

| S Ø 12 | S Ø 12,7 (1/2") | D | B | L |
|------------|------------------------|----|----|-----|
| E146.190.R | G146.190.R | 19 | 25 | 82 |
| E146.191.R | G146.191.R shear angle | 19 | 38 | 98 |
| E146.192.R | G146.192.R shear angle | 19 | 51 | 108 |



Z050.005.N



Z053.002.N



Z054.002.N



Z051.004.R

HW COVE BITS WITH BALL BEARING GUIDE

ART. E147 - G147

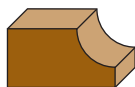
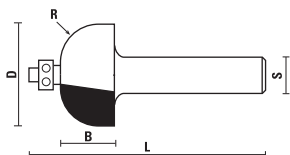

| S Ø 12 | S Ø 12,7 (1/2") | D | R | B | L | Z |
|------------|-----------------|------|------|----|----|---|
| E147.222.R | G147.222.R | 22,2 | 6,4 | 14 | 60 | 2 |
| E147.254.R | G147.254.R | 25,4 | 8 | 14 | 60 | 2 |
| E147.286.R | G147.286.R | 28,6 | 9,5 | 14 | 62 | 2 |
| E147.350.R | G147.350.R | 35 | 12,7 | 17 | 64 | 2 |
| E147.410.R | G147.410.R | 41 | 16 | 18 | 65 | 2 |



Z050.001.N



Z053.001.N



Z054.001.N



Z051.001.R

| S Ø 12 | S Ø 12,7 (1/2") | D | R | B | L | Z |
|------------|-----------------|----|----|----|----|---|
| E147.570.R | G147.570.R | 57 | 22 | 32 | 81 | 2 |



Z050.003.N



Z053.003.N



Z054.002.N



Z051.002.R

HW ROMAN OGEE BITS WITH BALL BEARING GUIDE Z=2

ART. E148 - G148

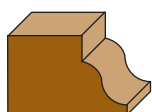
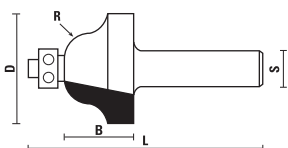

| S Ø 12 | S Ø 12,7 (1/2") | D | R | B | L |
|------------|-----------------|------|-----|----|----|
| E148.254.R | G148.254.R | 25,4 | 4 | 16 | 63 |
| E148.350.R | G148.350.R | 35 | 6,4 | 20 | 67 |



Z050.001.N



Z053.001.N



Z054.001.N



Z051.001.R

HW CLASSICAL OGEE BITS WITH BALL BEARING GUIDE Z=2

ART. E149 - G149

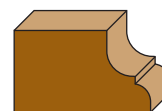
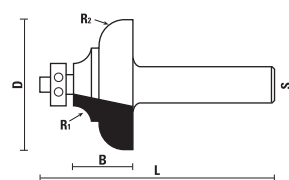

| S Ø 12 | S Ø 12,7 (1/2") | D | R1 | R2 | B | L |
|-------------|-----------------|------|-----|-----|----|----|
| E149.286.R | G149.286.R | 28,6 | 4 | 4 | 13 | 60 |
| E149.350.R | G149.350.R | 35 | 6 | 4,8 | 18 | 64 |
| E149.380.R* | | 38 | 4,7 | 8 | 16 | 65 |
| E149.510.R | G149.510.R | 51 | 9,5 | 9,5 | 23 | 72 |

* Selling out



Z050.003.N



Z053.003.N



Z054.002.N



Z051.002.R

HW RABBETING BITS WITH BALL BEARING GUIDE Z=2

ART. E150 - G150

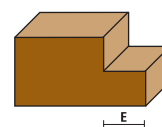
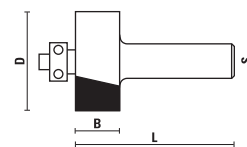

| S Ø 12 | S Ø 12,7 (1/2") | D | B | E | L |
|------------|-----------------|----|----|-----|----|
| E150.320.R | G150.320.R | 32 | 13 | 9,5 | 60 |
| E150.350.R | G150.350.R | 35 | 13 | 11 | 60 |

| | | | | | |
|------------|------------|----|----|---------------|----|
| E150.850.R | G150.850.R | 35 | 13 | 8-9,5-11-12,7 | 60 |
|------------|------------|----|----|---------------|----|



Z050.002.N
Z050.003.N
Z050.004.N
Z050.023.N



Z053.002.N
Z053.003.N
Z053.004.N



Z051.002.R

Art. E150.850.R/G150.850.R

Supplied with ball bearing set for different thickness rebates

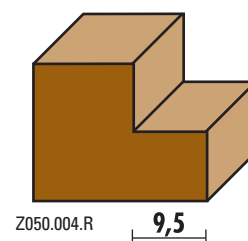
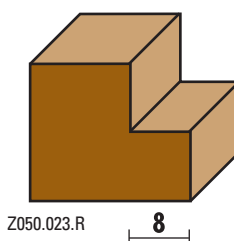

Scale 1:1

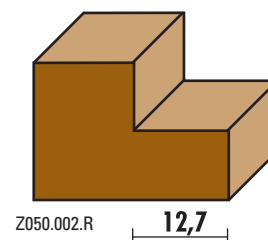
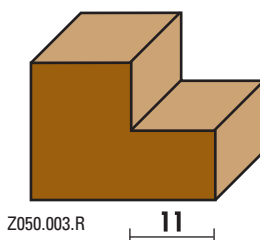

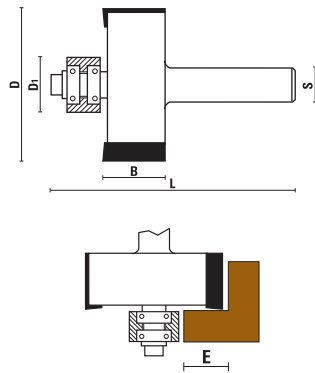

HW RABBETING BITS WITH BALL BEARING GUIDE Z=2

ART. E150 - G150



- Changing guide rings several thickness rebates 1,6 up to 18,25 mm can be obtained
 - This item is sold complete with a guide collar D=19 mm (our item Z050.903.N) to obtain rabbet width of E=16 mm.



| S Ø 12 | S Ø 12,7 (1/2") | D | D1 | B | E | L |
|---|---|----|----|---|----|----|
| E150.510.R | G150.510.R | 51 | 19 | 22,5 | 16 | 78 |
|  |  | | |  | | |
| Z050.007.N | Z057.010.N | | | Z051.008.R | | |





| Spare rings | D1 | E |
|-------------|------|-------|
| Z050.901.N | 14,3 | 18,25 |
| Z050.902.N | 16 | 17,5 |
| Z050.903.N | 19 | 16 |
| Z050.904.N | 20,6 | 15,2 |
| Z050.905.N | 22,2 | 14,3 |
| Z050.906.N | 25,4 | 12,7 |
| Z050.907.N | 27 | 12 |
| Z050.908.N | 28,6 | 11,1 |
| Z050.909.N | 31,8 | 9,5 |
| Z050.910.N | 32,5 | 9,25 |
| Z050.911.N | 35 | 8 |
| Z050.912.N | 38 | 6,4 |
| Z050.913.N | 39 | 6 |
| Z050.914.N | 41,3 | 4,8 |
| Z050.915.N | 44,4 | 3,2 |
| Z050.916.N | 47,6 | 1,6 |

Z050.999.N 16 rings set

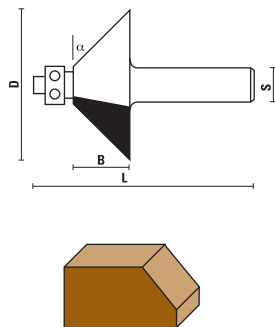
HW BEVEL TRIM BITS WITH BALL BEARING GUIDE Z=2

ART. E151 - G151



| S Ø 12 | S Ø 12,7 (1/2") | D | α | B | L |
|---|---|---|-----|---|----|
| E151.351.R | G151.351.R | 35 | 60° | 20,6 | 60 |
| E151.508.R | G151.508.R | 50,8 | 45° | 19 | 68 |
| E151.635.R | G151.635.R | 60,5 | 45° | 25 | 74 |
|  |  |  | |  | |
| Z050.003.N | Z053.003.N | Z054.002.N | | Z051.002.R | |

HW CORNER ROUNDING BITS WITH BALL BEARING GUIDE Z=2

ART. E152 - G152

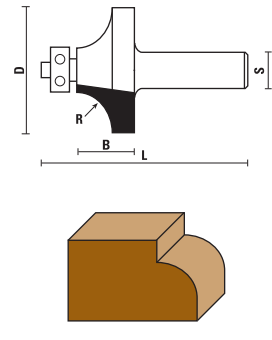

| S Ø 12 | S Ø 12,7 (1/2") | D | R | B | L |
|------------|-----------------------------|------|------|------|----|
| E152.191.R | G152.191.R | 19,1 | 3,2 | 9,5 | 59 |
| E152.207.R | G152.207.R | 20,7 | 4 | 10 | 59 |
| E152.220.R | G152.220.R | 22 | 5 | 13 | 62 |
| E152.254.R | G152.254.R | 25,4 | 6,4 | 13 | 62 |
| E152.286.R | G152.286.R | 28,6 | 8 | 14 | 62 |
| E152.318.R | G152.318.R | 31,8 | 9,5 | 16 | 65 |
| E152.327.R | | 32,7 | 10 | 16 | 65 |
| E152.367.R | | 36,7 | 12 | 20 | 67 |
| E152.380.R | G152.380.R | 38 | 12,7 | 19 | 67 |
| E152.410.R | G152.410.R* | 41 | 14 | 20 | 70 |
| E152.427.R | G152.427.R | 42,7 | 15 | 22 | 70 |
| E152.445.R | G152.445.R | 44,5 | 16 | 22,2 | 71 |
| E152.487.R | | 48,7 | 18 | 26 | 72 |
| E152.508.R | G152.508.R | 50,8 | 19 | 25,4 | 73 |
| E152.527.R | | 52,7 | 20 | 27 | 73 |
| E152.570.R | G152.570.R | 57 | 22 | 29 | 78 |
| E152.635.R | G152.635.R | 63,5 | 25 | 32 | 81 |
| E152.700.R | G152.700.R - max RPM 18.000 | 70 | 28 | 35 | 84 |
| E152.726.R | | 72,6 | 30 | 36 | 85 |
| E152.760.R | G152.760.R - max RPM 18.000 | 76 | 32 | 38 | 87 |
| E152.825.R | | 82,5 | 35 | 41 | 90 |
| E152.890.R | G152.890.R - max RPM 16.000 | 89 | 38 | 45 | 94 |

* Selling out





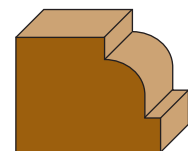

Changing the ball bearing art. Z050.003.N with art. Z050.002.N the profile shown can be obtained

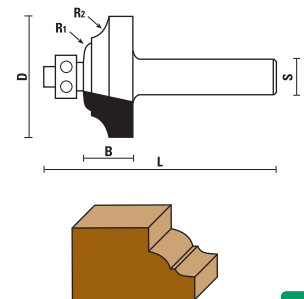

HW CLASSICAL BITS WITH BALL BEARING GUIDE Z=2

ART. E153



| S Ø 12 | D | R1 | R2 | B | L |
|--|---|---|---|------|------|
| E153.381.R | 38,1 | 5,5 | 6 | 15,9 | 63,5 |
|  |  |  |  | | |
| Z050.003.N | Z053.003.N | Z054.002.N | Z051.002.R | | |

HW OGEE BITS WITH BALL BEARING GUIDE Z=2

ART. E154 - G154

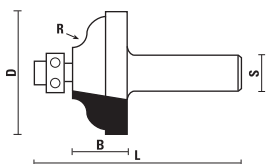

| S Ø 12 | S Ø 12,7 (1/2") | D | R | B | L |
|-------------|-----------------|------|-----|----|----|
| E154.350.R* | | 35 | 4 | 13 | 61 |
| E154.413.R | G154.413.R | 41,3 | 6,4 | 19 | 67 |
| E154.570.R* | | 57 | 9,5 | 25 | 75 |

* Selling out



Z050.002.N



Z053.002.N



Z054.002.N



Z051.002.R

HW MOULDING BITS WITH BALL BEARING GUIDE Z=2

ART. E156 - G156

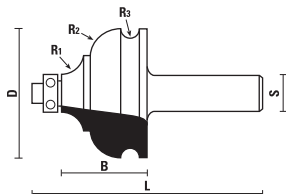

| S Ø 12 | S Ø 12,7 (1/2") | D | R1 | R2 | R3 | B | L |
|------------|-----------------|------|-----|-----|-----|------|------|
| E156.413.R | G156.413.R | 41,3 | 6,4 | 9,5 | 3,2 | 28,5 | 75,5 |



Z050.003.N



Z053.003.N



Z054.002.N



Z051.002.R

HW MOULDING BITS WITH BALL BEARING GUIDE Z=2

ART. E157 - G157

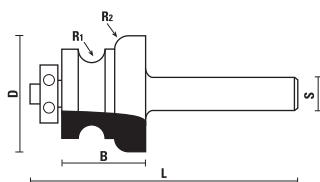

| S Ø 12 | S Ø 12,7 (1/2") | D | R1 | R2 | B | L |
|------------|-----------------|----|-----|----|----|----|
| E157.400.R | G157.400.R | 40 | 5,5 | 6 | 30 | 78 |



Z050.004.N



Z053.004.N



Z054.002.N



Z051.002.R

HW MOULDING BITS WITH BALL BEARING GUIDE Z=2

ART. E158 - G158

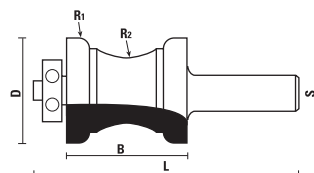

| S Ø 12 | S Ø 12,7 (1/2") | D | R1 | R2 | B | L |
|------------|-----------------|----|----|----|----|----|
| E158.350.R | G158.350.R | 35 | 5 | 13 | 40 | 88 |



Z050.004.N



Z053.004.N



Z054.002.N



Z051.002.R

HW DRAWING LINE BITS WITH BALL BEARING GUIDE Z=2

ART. E159

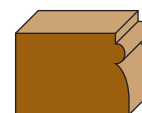
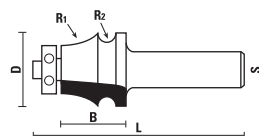

| S Ø 12 | D | R1 | R2 | B | L |
|-------------|------|----|-----|----|----|
| E159.254.R* | 25,4 | 19 | 3,2 | 22 | 70 |

* Selling out



Z050.004.N



Z053.004.N



Z054.002.N



Z051.002.R

HW DRAWING LINE BITS WITH BALL BEARING GUIDE Z=2

ART. E160

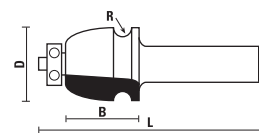

| S Ø 12 | D | R | B | L |
|-------------|----|-----|----|----|
| E160.260.R* | 26 | 3,5 | 25 | 74 |

* Selling out



Z050.003.N



Z053.003.N



Z054.002.N



Z051.002.R

HW DRAWING LINE BITS WITH BALL BEARING GUIDE Z=2

ART. E161 - G161

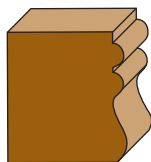
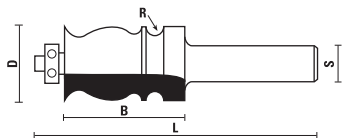

| S Ø 12 | S Ø 12,7 (1/2") | D | R | B | L |
|------------|-----------------|------------|------------|----|----|
| E161.254.R | G161.254.R | 25,4 | 3,5 | 45 | 94 |
| | | | | | |
| Z050.003.N | Z053.003.N | Z054.002.N | Z051.002.R | | |

HW ARCHITECTURAL MOULDING LINE BITS WITH BALL BEARING GUIDE Z=2

ART. E162 - G162

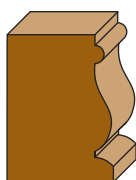
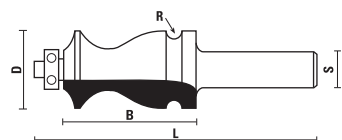

| S Ø 12 | S Ø 12,7 (1/2") | D | R | B | L |
|------------|-----------------|------------|------------|----|----|
| E162.270.R | G162.270.R | 27 | 3 | 45 | 94 |
| | | | | | |
| Z050.003.N | Z053.003.N | Z054.002.N | Z051.002.R | | |

HW ARCHITECTURAL MOULDING LINE BITS WITH BALL BEARING GUIDE Z=2

ART. E163 - G163

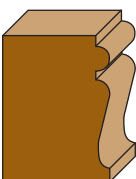
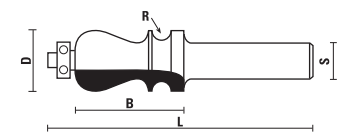

| S Ø 12 | S Ø 12,7 (1/2") | D | R | B | L |
|------------|-----------------|------------|------------|----|----|
| E163.220.R | G163.220.R | 22 | 4 | 38 | 87 |
| | | | | | |
| Z050.003.N | Z053.003.N | Z054.002.N | Z051.002.R | | |

HW MULTI RADIUS BITS Z=2

ART. E165 - G165

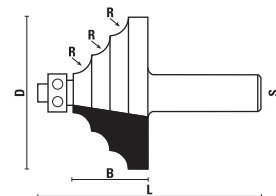

| S Ø 12 | S Ø 12,7 (1/2") | D | R | B | L |
|------------|-----------------|------------|------------|----|----|
| E165.470.R | G165.470.R | 47 | 6 | 24 | 73 |
| | | | | | |
| Z050.003.N | Z053.003.N | Z054.002.N | Z051.002.R | | |

HW MULTIPLE PROFILE BITS Z=2

ART. E166 - G166

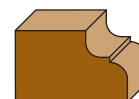
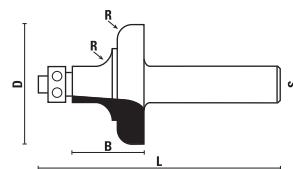

| S Ø 12 | S Ø 12,7 (1/2") | D | R | B | L |
|------------|-----------------|------------|------------|----|----|
| E166.510.R | G166.510.R | 51 | 8,5 | 31 | 80 |
| | | | | | |
| Z050.003.N | Z053.003.N | Z054.002.N | Z051.002.R | | |

HW MULTIPLE PROFILE BITS Z=2

ART. E167 - G167

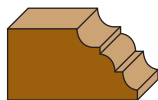
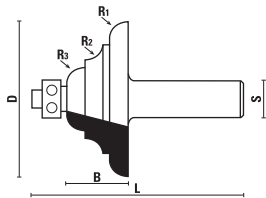

| S Ø 12 | S Ø 12,7 (1/2") | D | R1 | R2 | R3 | B | L |
|------------|-----------------|----|-----|-----|-----|----|----|
| E167.590.R | G167.590.R | 59 | 6,5 | 6,5 | 7,5 | 22 | 70 |



Z050.003.N



Z053.003.N



Z054.002.N



Z051.002.R

HW MULTIPLE PROFILE BITS Z=2

ART. E168 - G168

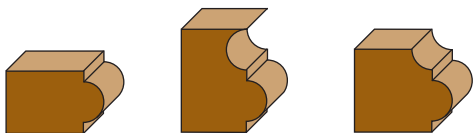
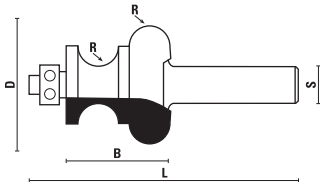

| S Ø 12 | S Ø 12,7 (1/2") | D | R | B | L |
|------------|-----------------|----|-----|----|----|
| E168.510.R | G168.510.R | 51 | 6,4 | 32 | 80 |



Z050.004.N



Z053.004.N



Z054.002.N



Z051.002.R

HW CLASSICAL MULTI-FORM BITS WITH BALL BEARING GUIDE Z=2

ART. E169 - G169

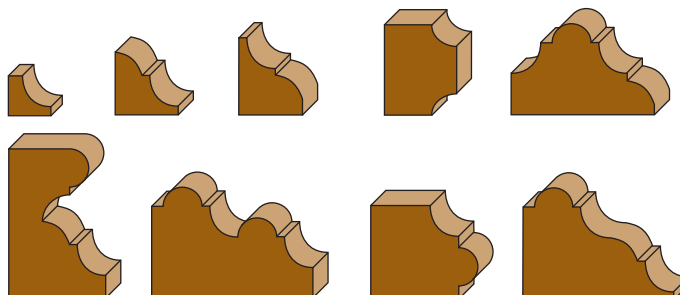
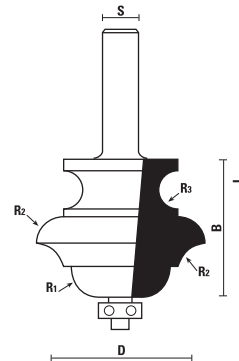

| S Ø 12 | S Ø 12,7 (1/2") | D | R1 | R2 | R3 | B | L |
|------------|------------------------------|----|----|-----|-----|----|----|
| E169.540.R | G169.540.R max RPM 18.000 | 54 | 9 | 8,5 | 6,4 | 47 | 96 |



Z050.003.N



Z053.003.N



Z054.002.N



Z051.002.R

HW HANDRAIL BITS WITH BALL BEARING GUIDE Z=2

ART. E170 - G170

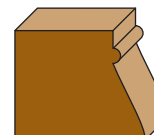
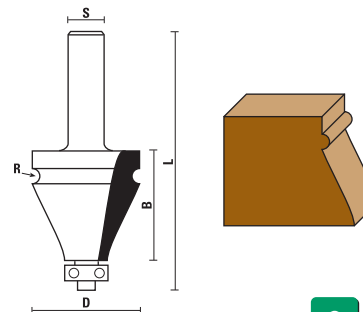

| S Ø 12 | S Ø 12,7 (1/2") | D | R | B | L |
|------------|-----------------|----|-----|----|----|
| E170.350.R | G170.350.R | 35 | 3,2 | 37 | 86 |



Z050.003.N



Z053.003.N



Z054.002.N



Z051.002.R

SAMPLE OF HANDRAIL PATTERNS

E170

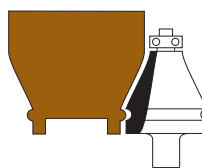

E171

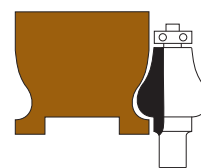

E176

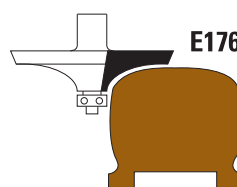

E177

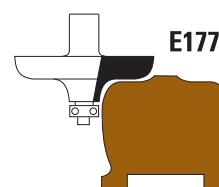

CONTACT US

(+39) 0721 28950

info@sistemiklein.com

HW HANDRAIL BITS WITH BALL BEARING GUIDE Z=2

ART. E171 - G171

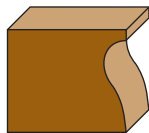
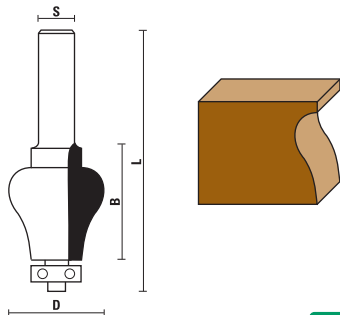

| S Ø 12 | S Ø 12,7 (1/2") | D | R | B |
|------------|-----------------|----|----|----|
| E171.320.R | G171.320.R | 32 | 38 | 87 |



Z050.003.N



Z053.003.N



Z054.002.N



Z051.002.R

HW EDGE BEADING BITS Z=2

ART. E172 - G172

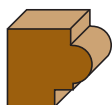
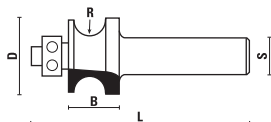

| S Ø 12 | S Ø 12,7 (1/2") | D | R | B | L |
|------------|-----------------|----|-----|----|----|
| E172.220.R | G172.220.R | 22 | 3,2 | 14 | 63 |
| E172.280.R | G172.280.R | 28 | 4,8 | 16 | 66 |
| E172.320.R | G172.320.R | 32 | 6,4 | 19 | 67 |
| E172.380.R | G172.380.R | 38 | 9,5 | 25 | 74 |



Z050.004.N



Z053.004.N



Z054.002.N



Z051.002.R

HW HANDRAIL AND TABLE EDGE BITS Z=2

ART. E173 - G173

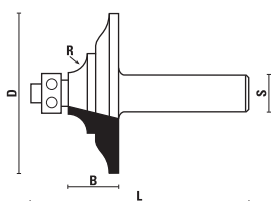

| S Ø 12 | S Ø 12,7 (1/2") | D | R | B | L |
|------------|-----------------------------|----|-----|----|----|
| E173.640.R | G173.640.R - max RPM 18.000 | 64 | 6,5 | 20 | 69 |



Z050.003.N



Z053.003.N



Z054.002.N



Z051.002.R

HW HANDRAIL AND TABLE EDGE BITS Z=2

ART. E174 - E174

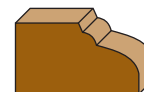
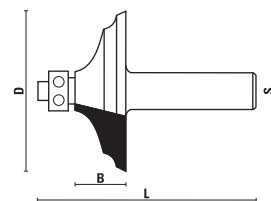
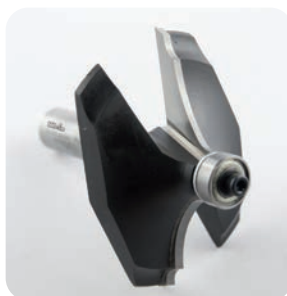

| S Ø 12 | S Ø 6,4 (1/4") | D | B | L |
|------------|-----------------------------|----|----|----|
| E174.660.R | G174.660.R - max RPM 18.000 | 66 | 20 | 69 |



Z050.003.N



Z053.003.N



Z054.002.N



Z051.002.R

HW RAISED PANEL BITS WITH BALL BEARING GUIDE Z=2

ART. E175 - E175

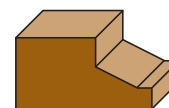
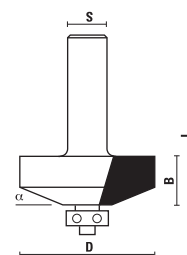

| S Ø 12 | S Ø 12,7 (1/2") | D | α | B | L |
|------------|-----------------|----|-----|----|----|
| E175.420.R | G175.420.R | 42 | 25° | 13 | 62 |



Z050.003.N



Z053.003.N



Z054.002.N



Z051.002.R

HW HANDRAIL-TABLE EDGE BITS WITH BALL BEARING GUIDE Z=2

ART. E176 - G176

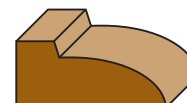
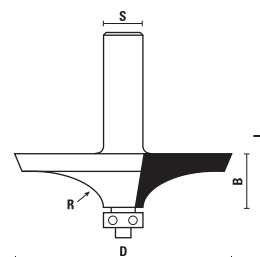

| S Ø 12 | S Ø 6,4 (1/4") | D | R | B | L |
|------------|-----------------------------|----|----|----|----|
| E176.690.R | G176.690.R - max RPM 18.000 | 69 | 43 | 16 | 64 |



Z050.003.N



Z053.003.N



Z054.002.N



Z051.002.R

HW HANDRAIL-TABLE EDGE BITS WITH BALL BEARING GUIDE Z=2

ART. E177 - G177

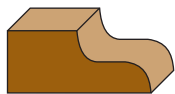
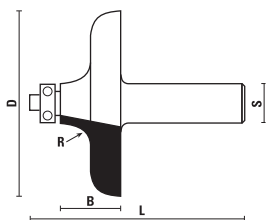

| S Ø 12 | S Ø 12,7 (1/2") | D | R | B | L |
|------------|-----------------------------|------------|------------|----|----|
| E177.640.R | G177.640.R - max RPM 18.000 | 64 | 9,5 | 20 | 69 |
| | | | | | |
| Z050.003.N | Z053.003.N | Z054.002.N | Z051.002.R | | |

HW RAISED PANEL BITS WITH BALL BEARING GUIDE Z=2

ART. E178 - G178

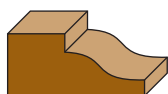
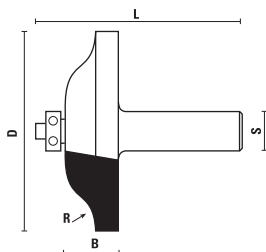

| S Ø 12 | S Ø 12,7 (1/2") | D | R | B | L |
|------------|-----------------------------|------------|------------|----|----|
| E178.670.R | G178.670.R - max RPM 18.000 | 67 | 19 | 17 | 65 |
| E178.860.R | G178.860.R - max RPM 16.000 | 86 | 22 | 16 | 65 |
| | | | | | |
| Z050.003.N | Z053.003.N | Z054.002.N | Z051.002.R | | |

HW RAISED PANEL BITS WITH BALL BEARING GUIDE Z=2

ART. E178 - G178

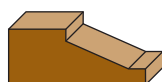
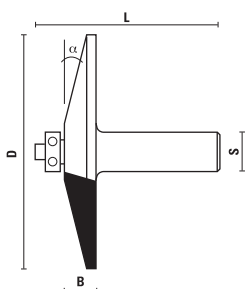

| S Ø 12 | S Ø 12,7 (1/2") | D | α | B | L |
|------------|-----------------------------|------------|------------|----|----|
| E178.861.R | G178.861.R - max RPM 16.000 | 86 | 15° | 13 | 61 |
| | | | | | |
| Z050.003.N | Z053.003.N | Z054.002.N | Z051.002.R | | |

HW RAISED PANEL BITS WITH BALL BEARING GUIDE Z=2

ART. E178 - G178

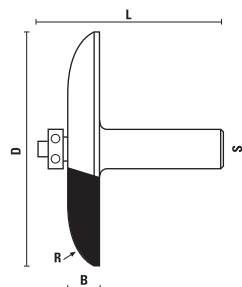

| S Ø 12 | S Ø 12,7 (1/2") | D | R | B | L |
|------------|-----------------------------|------------|------------|----|----|
| E178.862.R | G178.862.R - max RPM 16.000 | 86 | 40 | 13 | 61 |
| | | | | | |
| Z050.003.N | Z053.003.N | Z054.002.N | Z051.002.R | | |

HW RAISED PANEL BITS WITH BALL BEARING GUIDE Z=2

ART. E179 - G179

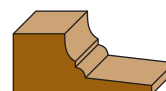
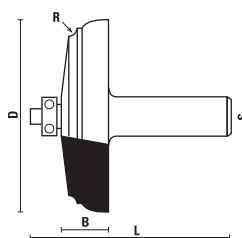

| S Ø 12 | S Ø 12,7 (1/2") | D | R | B | L |
|------------|-----------------------------|------------|------------|----|----|
| E179.640.R | G179.640.R - max RPM 18.000 | 64 | 3 | 13 | 62 |
| | | | | | |
| Z050.003.N | Z053.003.N | Z054.002.N | Z051.002.R | | |

HW FINGER JOINT ASSEMBLY WITH BALL BEARING GUIDE Z=2

ART. E180 - G180

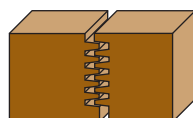
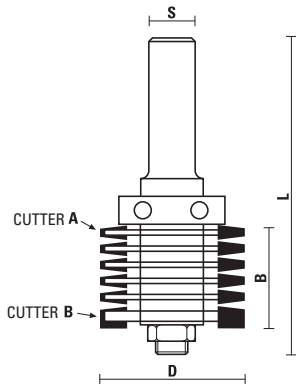

Working height 11 to 36 mm



| S Ø 12 | S Ø 12,7 (1/2") | D | B | L | Z |
|------------|-----------------|------|----|----|---|
| E180.397.R | G180.397.R | 39,7 | 36 | 96 | 2 |

SPARE PARTS

Arbor

| S Ø 12 | S Ø 12,7 (1/2") |
|------------|-----------------|
| E117.120.R | G117.120.R |

Finger cutter "A" (5 pcs.) Ø 39,2 x 1,85 d=8 Z=2
C180.500.R

Straight cutter "B" (1 pcs.) Ø 39,7 x 5,5 d=8 Z=2
C180.501.R



Z050.010.N



Z057.001.N - 6 pcs.



Z057.002.N - 2 pcs.
Z057.003.N - 1 pcs.
Z057.004.N - 10 pcs.

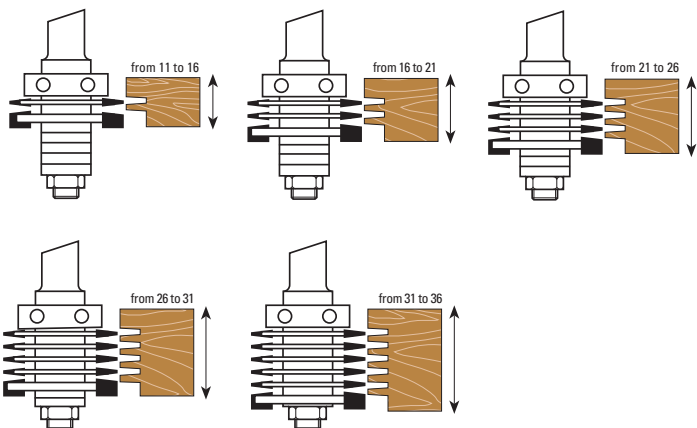

HW FINGER JOINT ASSEMBLY WITH BALL BEARING GUIDE Z=3

ART. E181 - G181

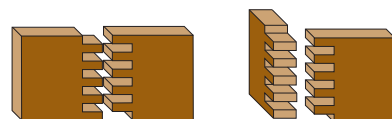
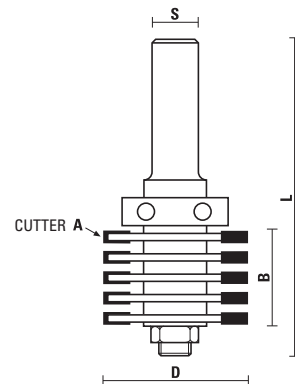

- Working height 22 to 45 mm
- Supplied with nr. 3 ball bearings for producing nr. 3 different cutting depths (E=9,8 - E=9,3 - E=6,8)



| S Ø 12 | S Ø 12,7 (1/2") | D | B | L | Z | E |
|------------|-----------------|------|----|----|---|-----|
| E181.476.R | G181.476.R | 47,6 | 36 | 96 | 3 | 9,8 |

SPARE PARTS

Arbor

| S Ø 12 | S Ø 12,7 (1/2") |
|------------|-----------------|
| E117.120.R | G117.120.R |

Finger cutter "A" (5 pcs.) Ø 47,6 x 4 d=8 Z=3
C118.340.R



Z050.107.N - 1 pcs.
Z050.108.N - 1 pcs.
Z050.109.N - 1 pcs.



Z057.009.N - 4 pcs.



Z057.004.N - 4 pcs.
Z057.008.N - 8 pcs.

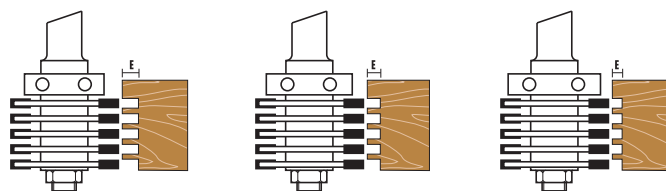

Z050.107.N
Ball bearing Ø28
E=9,8

Z050.108.N
Ball bearing Ø29
E=9,3

Z050.109.N
Ball bearing Ø34
E=6,8

HW SLOT CUTTER SET WITH BALL BEARING GUIDE Z=2

ART. E182 - G182

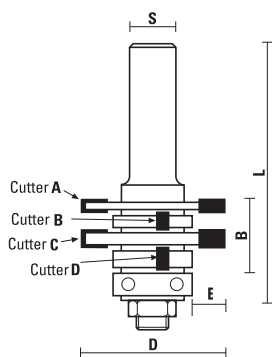

- For groovings 3,2 mm up to 18 mm
 - Some possible combinations to obtain different measures of grooves
 - Adding or removing the spacers included in the kit, can be obtained more measures (see drawing)



| S Ø 12 | S Ø 12,7 (1/2") | D | B | L | Z | E |
|------------|-----------------|------|--------|----|---|------|
| E182.476.R | G182.476.R | 47,6 | 3,2÷18 | 76 | 2 | 12,8 |

SPARE PARTS

Arbor

| S Ø 12 | S Ø 12,7 (1/2") |
|------------|-----------------|
| E117.123.R | G117.123.R |

Cutter (4 pcs.)

| | | | |
|------------------|--------------|-----|-----|
| "A" - C118.232.R | Ø 47,6 x 3,2 | d=8 | Z=2 |
| "B" - C118.240.R | Ø 47,6 x 4 | d=8 | Z=2 |
| "C" - C118.248.R | Ø 47,6 x 4,8 | d=8 | Z=2 |
| "D" - C118.264.R | Ø 47,6 x 6,4 | d=8 | Z=2 |



Z050.008.N - 1 pcs.



Z057.006.N - 3 pcs.
Z057.002.N - 5 pcs.



Z057.003.N - 5 pcs.
Z057.004.N - 10 pcs.

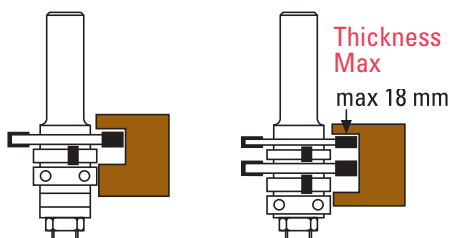
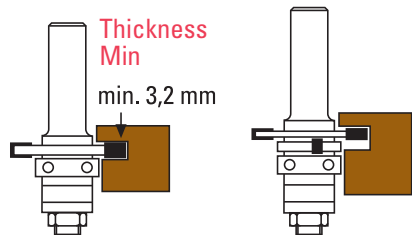

HW DOUBLE CORNER ROUND ASSEMBLY WITH BALL BEARING GUIDE Z=3

ART. E186 - G186 - C186

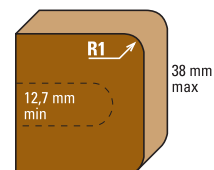
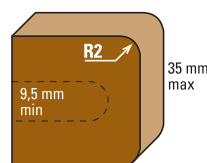
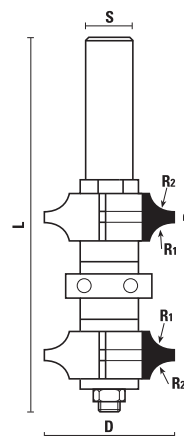

- R2 = 4,8 mm (working height 9,5 to 35 mm)
 - R1 = 6,4 mm (working height 12,7 to 38 mm)



| S Ø 12 | S Ø 12,7 (1/2") | S Ø 8 | D | R1 | R2 | B | L |
|------------|-----------------|------------|----|-----|-----|----|-----|
| E186.350.R | G186.350.R | C186.350.R | 35 | 6,4 | 4,8 | 14 | 108 |

SPARE PARTS

Arbor

| S Ø 12 | S Ø 12,7 (1/2") | S Ø 8 |
|------------|-----------------|------------|
| E117.121.R | G117.121.R | C117.081.R |

Top cutter Ø 35/Ø 8 Z=3 R1=6,4 R2=4,8
 C186.500.R

Bottom cutter Ø 35/Ø 8 Z=3 R1=6,4 R2=4,8
 C186.501.R



Z050.008.N - 1 pcs.



Z057.002.N - 2 pcs.
Z057.005.N - 2 pcs.
Z057.006.N - 2 pcs.



Z057.003.N - 1 pcs.
Z057.004.N - 4 pcs.

HW DOUBLE CHAMFER ASSEMBLY WITH BALL BEARING GUIDE Z=3

ART. E187 - G187 - C187

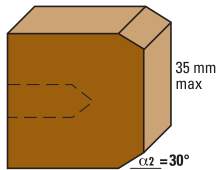
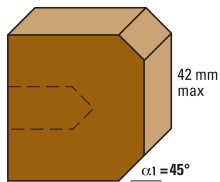
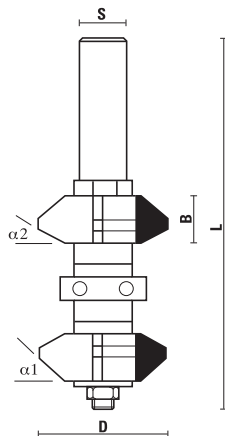

- $\alpha 1 = 45^\circ$ (Working height 0 to 42 mm)
- $\alpha 2 = 30^\circ$ (Working height 0 to 35 mm)



| S Ø 12 | S Ø 12,7 (1/2") | S Ø 8 | D | B | $\alpha 1$ | $\alpha 2$ | L |
|------------|-----------------|------------|----|----|------------|------------|-----|
| E187.350.R | G187.350.R | C187.350.R | 35 | 14 | 45° | 30° | 108 |

SPARE PARTS

Arbor

| S Ø 12 | S Ø 12,7 (1/2") | S Ø 8 |
|------------|-----------------|------------|
| E117.121.R | G117.121.R | C117.081.R |

| Top cutter | Ø 35/Ø 8 | Z=3 | $\alpha 1=45^\circ$ | $\alpha 2=30^\circ$ |
|------------|----------|-----|---------------------|---------------------|
| C187.500.R | | | | |

| Bottom cutter | Ø 35/Ø 8 | Z=3 | $\alpha 1=45^\circ$ | $\alpha 2=30^\circ$ |
|---------------|----------|-----|---------------------|---------------------|
| C187.501.R | | | | |



Z050.008.N - 1 pcs.



Z057.002.N - 3 pcs.
Z057.005.N - 2 pcs.
Z057.006.N - 2 pcs.



Z057.003.N - 1 pcs.
Z057.004.N - 4 pcs.

HW BEAD PANELING ASSEMBLY WITH BALL BEARING GUIDE Z=2

ART. E188 - G188 - C188

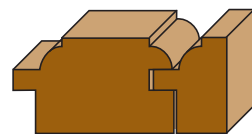
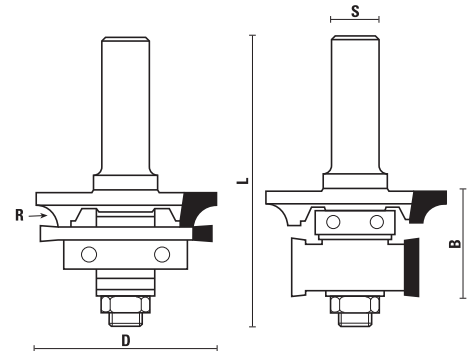

| S Ø 12 | S Ø 12,7 (1/2") | S Ø 8 | D | R | B | L |
|------------|-----------------|------------|----|---|----|----|
| E188.490.R | G188.490.R | C188.490.R | 49 | 6 | 30 | 80 |

SPARE PARTS

Arbor

| S Ø 12 | S Ø 12,7 (1/2") | S Ø 8 |
|------------|-----------------|------------|
| E117.122.R | G117.122.R | C117.082.R |

| Profile cutter | Ø 49 x 9 | d=8 | Z=2 |
|----------------|----------|-----|-----|
| C188.500.R | | | |

| Grooving cutter | Ø 46 x 4 | d=8 | Z=2 |
|-----------------|----------|-----|-----|
| C188.501.R | | | |

| Rabbeting cutter | Ø 33,5 x 17,5 | d=8 | Z=2 |
|------------------|---------------|-----|-----|
| C188.502.R | | | |



Z050.008.N - 1 pcs.
Z050.016.N - 1 pcs.



Z057.002.N - 2 pcs.
Z057.005.N - 3 pcs.



Z057.003.N - 1 pcs.
Z057.007.N - 1 pcs.
Z057.004.N - 3 pcs.
Z057.008.N - 1 pcs.

HW V PANELING ASSEMBLY WITH BALL BEARING GUIDE Z=2

ART. E189 - G189 - C189

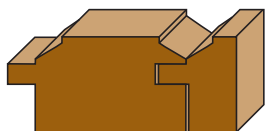
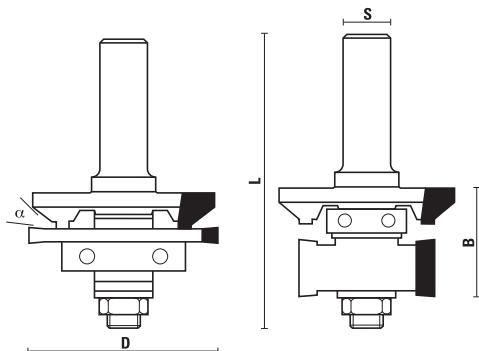

| S Ø 12 | S Ø 12,7 (1/2") | S Ø 8 | D | α | B | L |
|------------|-----------------|------------|------|-----|----|----|
| E189.425.R | G189.425.R | C189.425.R | 42,5 | 45° | 30 | 80 |

SPARE PARTS

Arbor

| S Ø 12 | S Ø 12,7 (1/2") | S Ø 8 |
|------------|-----------------|------------|
| E117.122.R | G117.122.R | C117.082.R |

| Profile cutter 45° | Ø 42,5 x 9 | d=8 | Z=2 |
|--------------------|------------|-----|-----|
| C189.500.R | | | |

| Grooving cutter | Ø 46 x 4 | d=8 | Z=2 |
|-----------------|----------|-----|-----|
| C188.501.R | | | |

| Rabbeting cutter | Ø 33,5 x 17,5 | d=8 | Z=2 |
|------------------|---------------|-----|-----|
| C188.502.R | | | |

 Z050.008.N - 1 pcs.
Z050.016.N - 1 pcs.

 Z057.002.N - 2 pcs.
Z057.005.N - 3 pcs.

 Z057.003.N - 1 pcs.
Z057.007.N - 1 pcs.
Z057.004.N - 3 pcs.
Z057.008.N - 1 pcs.

HW OGEE WINDOW SASH ASSEMBLY WITH BALL BEARING GUIDE Z=2

ART. E191 - G191 - C191

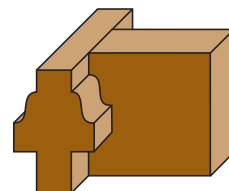
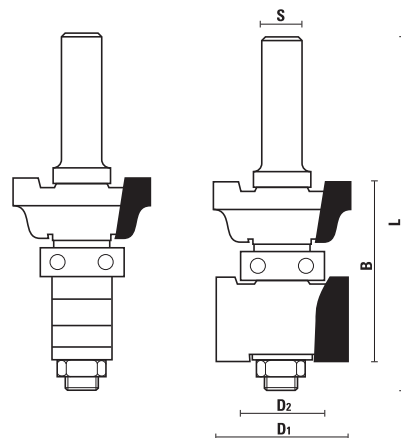

| S Ø 12 | S Ø 12,7 (1/2") | S Ø 8 | D1 | D2 | B | L |
|------------|-----------------|------------|----|----|----|----|
| E191.350.R | G191.350.R | C191.350.R | 35 | 22 | 47 | 96 |

SPARE PARTS

Arbor

| S Ø 12 | S Ø 12,7 (1/2") | S Ø 8 |
|------------|-----------------|------------|
| E117.120.R | G117.120.R | C117.080.R |

| Profile cutter | Ø 35 x 17 | d=8 | Z=2 |
|----------------|-----------|-----|-----|
| C191.500.R | | | |

| Rabbeting cutter | Ø 35 x 22 | d=8 | Z=2 |
|------------------|-----------|-----|-----|
| C191.501.R | | | |

 Z050.008.N - 1 pcs.

 Z057.005.N - 1 pcs.
Z057.006.N - 3 pcs.

 Z057.003.N - 1 pcs.
Z057.004.N - 3 pcs.
Z057.008.N - 1 pcs.

visit our website

www.sistemiklein.com



HW TONGUE AND GROOVE ASSEMBLY WITH BALL BEARING GUIDE Z=2

ART. E193 - G193 - C193

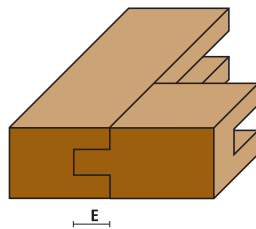
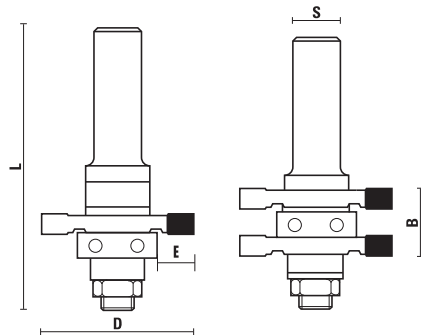

| S Ø 12 | S Ø 12,7 (1/2") | S Ø 8 | D | B | L | E |
|------------|-----------------|------------|----|----|----|-----|
| E193.410.R | G193.410.R | | 41 | 19 | 76 | 9,5 |
| | | C193.410.R | 41 | 19 | 70 | 9,5 |

SPARE PARTS

Arbor

| S Ø 12 | S Ø 12,7 (1/2") | S Ø 8 |
|------------|-----------------|------------|
| E117.123.R | G117.123.R | C117.079.R |

Grooving cutter (2 pcs.) Ø 41 x 6,4 d=8 Z=2
C193.500.R



Z050.008.N - 1 pcs.



Z057.002.N - 1 pcs.
Z057.006.N - 2 pcs.



Z057.004.N - 4 pcs.
Z057.008.N - 2 pcs.

HW STILE AND RAIL ASSEMBLY WITH BALL BEARING GUIDE Z=2

ART. E194 - G194 - C194

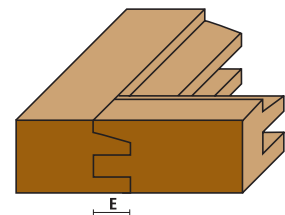
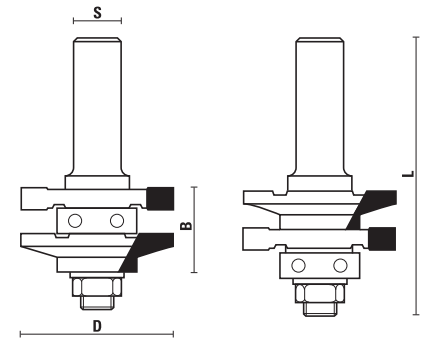

| S Ø 12 | S Ø 12,7 (1/2") | S Ø 8 | D | B | L | E |
|------------|-----------------|------------|----|----|----|-----|
| E194.410.R | G194.410.R | | 41 | 22 | 76 | 9,5 |
| | | C194.410.R | 41 | 22 | 70 | 9,5 |

SPARE PARTS

Arbor

| S Ø 12 | S Ø 12,7 (1/2") | S Ø 8 |
|------------|-----------------|------------|
| E117.123.R | G117.123.R | C117.079.R |

Profile cutter Ø 41 x 11 d=8 Z=2
C194.500.R

Grooving cutter Ø 41 x 6,4 d=8 Z=2
C193.500.R



Z050.008.N - 1 pcs.



Z057.004.N - 3 pcs.
Z057.008.N - 1 pcs.

HW STILE AND RAIL ASSEMBLY WITH BALL BEARING GUIDE Z=2

ART. E195 - G195 - C195

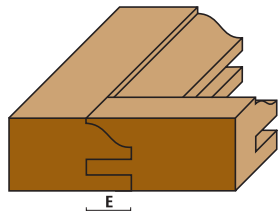
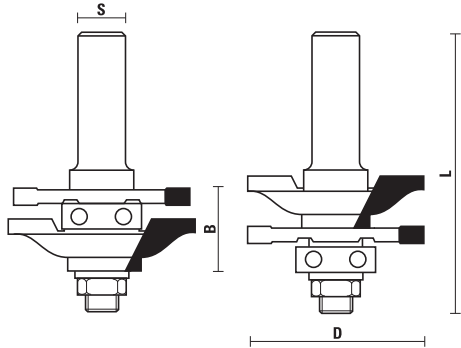

| S Ø 12 | S Ø 12,7 (1/2") | S Ø 8 | D | B | L | E |
|------------|-----------------|------------|----|----|----|----|
| E195.460.R | G195.460.R | | 46 | 22 | 76 | 12 |
| | | C195.460.R | 46 | 22 | 70 | 12 |

SPARE PARTS

| Arbor | | |
|------------|-----------------|------------|
| S Ø 12 | S Ø 12,7 (1/2") | S Ø 8 |
| E117.123.R | G117.123.R | C117.079.R |

| Profile cutter | Ø 46 x 15 | d=8 | Z=2 |
|----------------|-----------|-----|-----|
| C195.500.R | | | |

| Grooving cutter | Ø 46 x 4 | d=8 | Z=2 |
|-----------------|----------|-----|-----|
| C188.501.R | | | |



Z050.008.N - 1 pcs.



Z057.004.N - 3 pcs.
Z057.008.N - 1 pcs.

HW STILE AND RAIL ASSEMBLY WITH BALL BEARING GUIDE Z=2

ART. E196 - G196 - C196

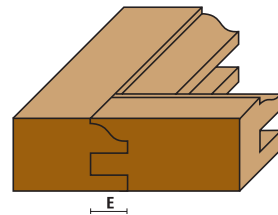
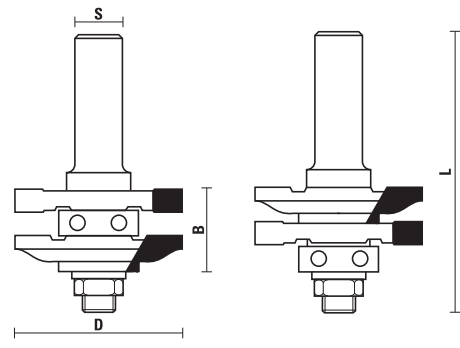

| S Ø 12 | S Ø 12,7 (1/2") | S Ø 8 | D | B | L | E |
|------------|-----------------|------------|----|----|----|-----|
| E196.410.R | G196.410.R | | 41 | 22 | 76 | 9,5 |
| | | C196.410.R | 41 | 22 | 70 | 9,5 |

SPARE PARTS

| Arbor | | |
|------------|-----------------|------------|
| S Ø 12 | S Ø 12,7 (1/2") | S Ø 8 |
| E117.123.R | G117.123.R | C117.079.R |

| Profile cutter | Ø 41 x 11 | d=8 | Z=2 |
|----------------|-----------|-----|-----|
| C196.500.R | | | |

| Grooving cutter | Ø 41 x 6,4 | d=8 | Z=2 |
|-----------------|------------|-----|-----|
| C193.500.R | | | |



Z050.008.N - 1 pcs.



Z057.004.N - 2 pcs.
Z057.008.N - 2 pcs.

HW STILE AND RAIL ASSEMBLY WITH BALL BEARING GUIDE Z=2

ART. E197 - G197 - C197

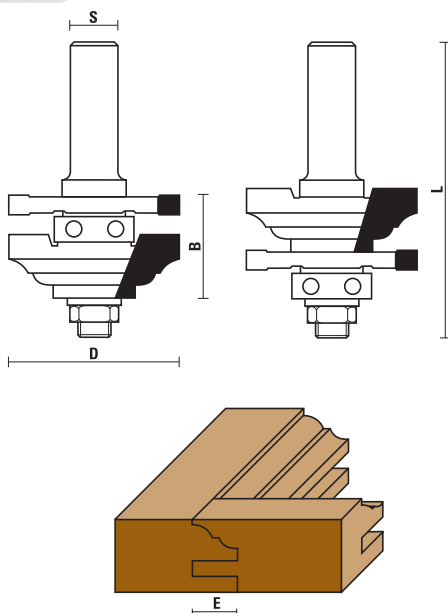

| S Ø 12 | S Ø 12,7 (1/2") | S Ø 8 | D | B | L | E |
|------------|-----------------|------------|----|----|----|----|
| E197.460.R | G197.460.R | | 46 | 22 | 76 | 12 |
| | | C197.460.R | 46 | 22 | 70 | 12 |

SPARE PARTS

Arbor

| S Ø 12 | S Ø 12,7 (1/2") | S Ø 8 |
|------------|-----------------|------------|
| E117.123.R | G117.123.R | C117.079.R |

Profile cutter

C197.500.R

Ø 46 x 15 d=8 Z=2

Grooving cutter

C188.501.R

Ø 46 x 4 d=8 Z=2



Z050.008.N - 1 pcs.



Z057.004.N - 2 pcs.
Z057.008.N - 2 pcs.

HW STILE AND RAIL ASSEMBLY WITH BALL BEARING GUIDE Z=2

ART. E198 - G198 - C198

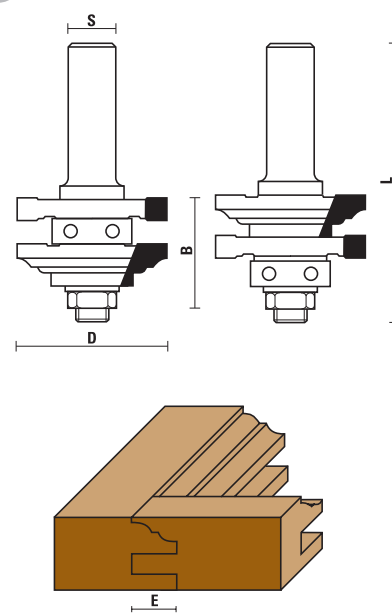

| S Ø 12 | S Ø 12,7 (1/2") | S Ø 8 | D | B | L | E |
|------------|-----------------|------------|----|----|----|-----|
| E198.410.R | G198.410.R | | 41 | 22 | 76 | 9,5 |
| | | C198.410.R | 41 | 22 | 70 | 9,5 |

SPARE PARTS

Arbor

| S Ø 12 | S Ø 12,7 (1/2") | S Ø 8 |
|------------|-----------------|------------|
| E117.123.R | G117.123.R | C117.079.R |

Profile cutter

C198.500.R

Ø 41 x 11 d=8 Z=2

Grooving cutter

C193.500.R

Ø 41 x 6,4 d=8 Z=2



Z050.008.N - 1 pcs.



Z057.004.N - 2 pcs.
Z057.008.N - 2 pcs.

HW BEADING BITS FOR RADIUS WINDOW Z=2

ART. E199 - C199

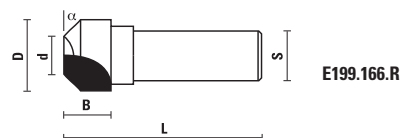
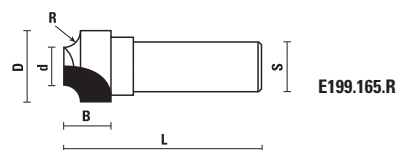
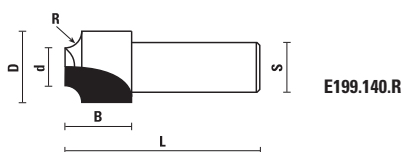
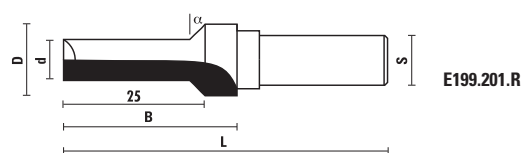
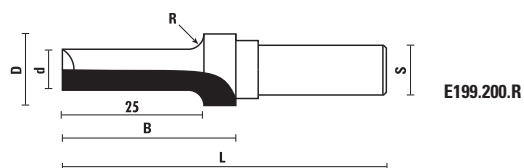
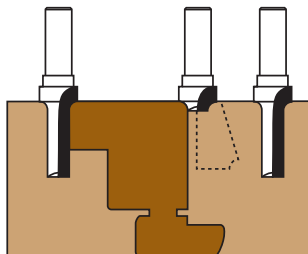

- To use on "ARKADE + ZINKEL" or on similar equipment
 - Bits for glass-fixing lath see item Art. T141.061.R (HW) page 7.38
 and Art. U211.061.R (HS) page 8.08



| S Ø 12 | S Ø 8 | D | d | R | α | B | L |
|------------|------------|------|-----|---|-----|----|----|
| E199.140.R | C199.140.R | 14 | 6 | 3 | 16 | 46 | |
| E199.165.R | C199.165.R | 16,5 | 8,5 | 3 | 11 | 46 | |
| E199.166.R | C199.166.R | 16,5 | 8,5 | | 45° | 11 | 46 |
| E199.200.R | C199.200.R | 20 | 12 | 3 | 33 | 68 | |
| E199.201.R | C199.201.R | 20 | 12 | | 45° | 33 | 68 |

The device for any single and double radius or elliptical frames

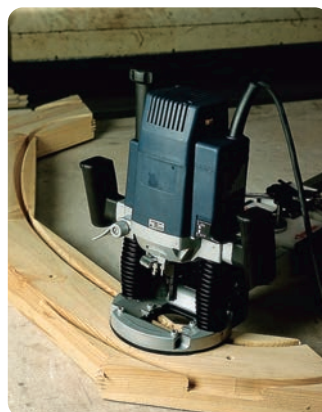
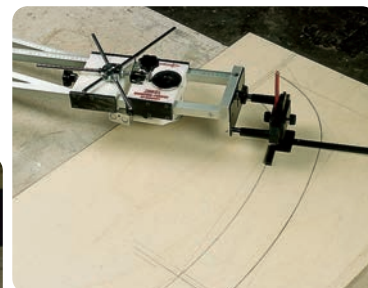
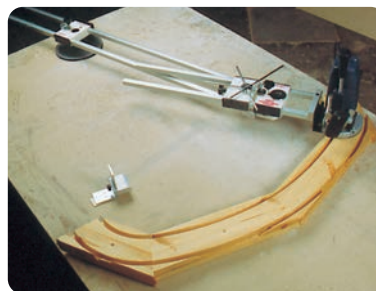

See section 16 page 16.03

2 PIECE SET FOR CABINET DOORS MAKER "TYPE 1"

ART. X021

- Set including stile and rail bit, raised panel bit.
- Practical plastic case.

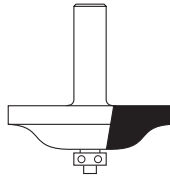

E178.860.R

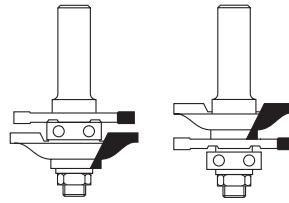

E195.460.R

Item

| | |
|-----------------------|------------------------------|
| X021.012.R (S Ø 12) | X021.127.R (S Ø 12,7 (1/2")) |
| 2-pcs router bit set: | 2-pcs router bit set: |
| E178.860.R | G178.860.R |
| E195.460.R | G195.460.R |

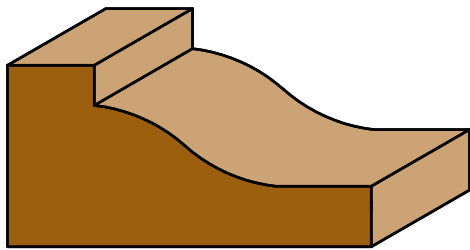

E178.860.R

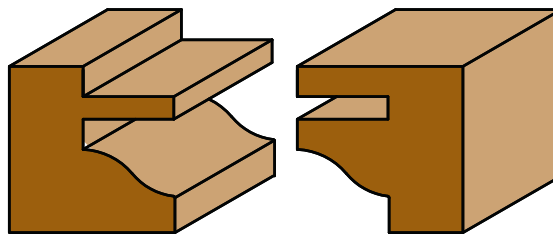

E195.460.R

Scale 1:1

2 PIECE SET FOR CABINET DOORS MAKER "TYPE 2"

ART. X022

- Set including stile and rail bit, raised panel bit.
- Practical plastic case.

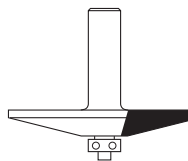

E178.861.R

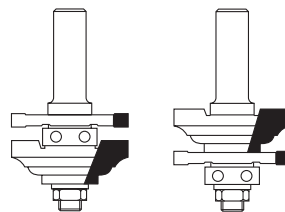

E197.460.R

Item

| | |
|-----------------------|------------------------------|
| X022.012.R (S Ø 12) | X022.127.R (S Ø 12,7 (1/2")) |
| 2-pcs router bit set: | 2-pcs router bit set: |
| E178.861.R | G178.861.R |
| E197.460.R | G197.460.R |

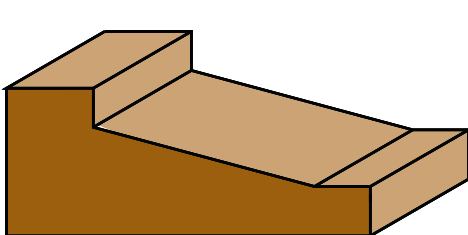

E178.861.R

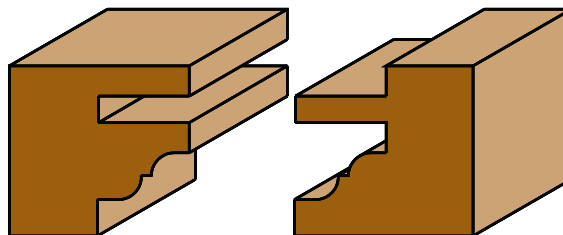

E197.460.R

Scale 1:1

2 PIECE SET FOR CABINET DOORS MAKER "TYPE 3"

ART. X023

- Set including stile and rail bit, raised panel bit.
- Practical plastic case.

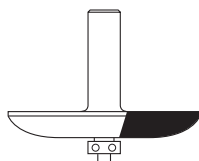

E178.862.R

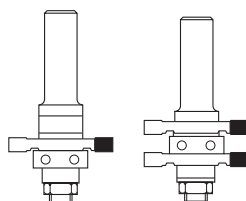

E193.410.R

| Item | |
|-----------------------|------------------------------|
| X023.012.R (S Ø 12) | X023.127.R (S Ø 12,7 (1/2")) |
| 2-pcs router bit set: | 2-pcs router bit set: |
| E178.862.R | G178.862.R |
| E193.410.R | G193.410.R |

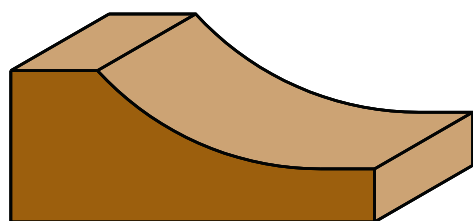

E178.862.R

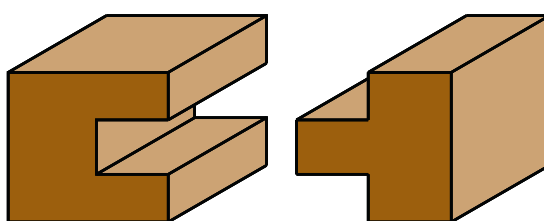

E193.410.R

Scale 1:1

3 PIECE SET FOR CABINET DOORS MAKER AND JOINTS "TYPE 1"

ART. X024

- Set including stile and rail bit, raised panel bit and slot cutter.
- Practical plastic case.

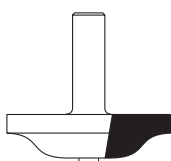

E178.860.R

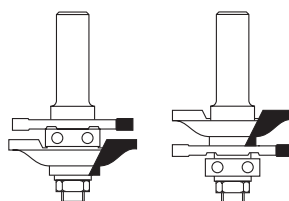

E195.460.R



E182.476.R

| Item | |
|-----------------------|------------------------------|
| X024.012.R (S Ø 12) | X024.127.R (S Ø 12,7 (1/2")) |
| 3-pcs router bit set: | 3-pcs router bit set: |
| E178.860.R | G178.860.R |
| E195.460.R | G195.460.R |
| E182.476.R | G182.476.R |

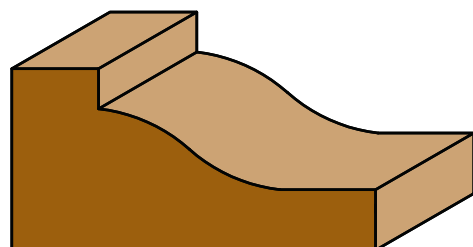

E178.860.R

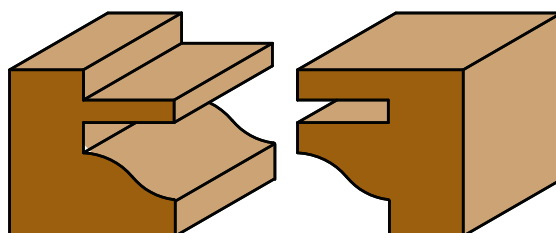

E195.460.R

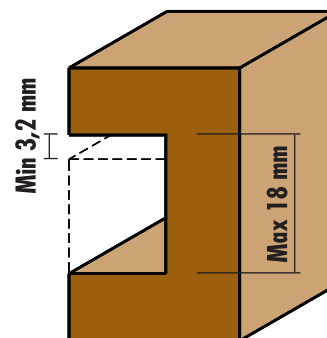

E182.476.R

Scale 1:1

3 PIECE SET FOR CABINET DOORS MAKER AND JOINTS "TYPE 2"

ART. X025

- Set including stile and rail bit, raised panel bit and slot cutter.

- Practical plastic case.

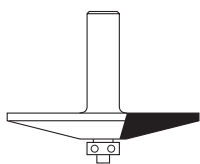

E178.861.R

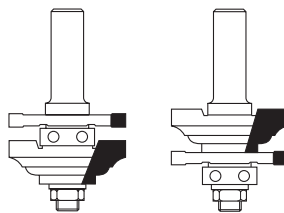

E197.460.R



E182.476.R

Item

| | |
|-----------------------|------------------------------|
| X025.012.R (S Ø 12) | X025.127.R (S Ø 12,7 (1/2")) |
| 3-pcs router bit set: | 3-pcs router bit set: |
| E178.861.R | G178.861.R |
| E197.460.R | G197.460.R |
| E182.476.R | G182.476.R |

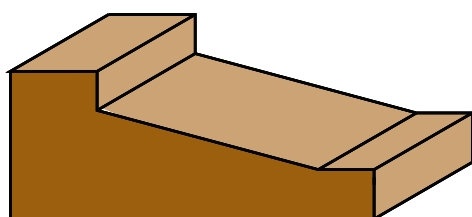

E178.861.R

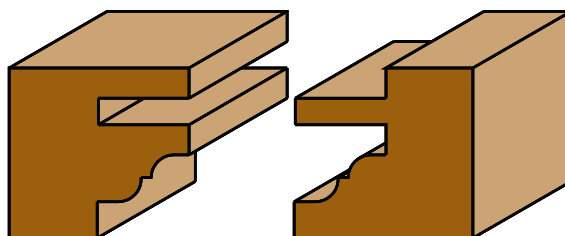

E197.460.R

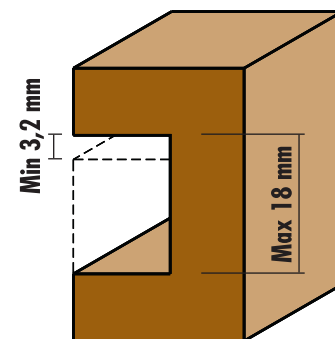

E182.476.R

Scale 1:1

3 PIECE SET FOR CABINET DOORS MAKER AND JOINTS "TYPE 3"

ART. X026

- Set including stile and rail bit, raised panel bit and slot cutter.

- Practical plastic case.

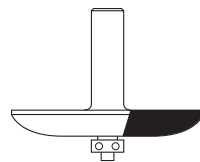

E178.862.R

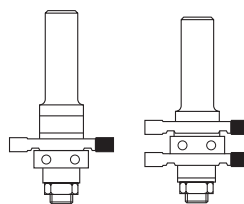

E193.410.R



E182.476.R

Item

| | |
|-----------------------|------------------------------|
| X026.012.R (S Ø 12) | X026.127.R (S Ø 12,7 (1/2")) |
| 3-pcs router bit set: | 3-pcs router bit set: |
| E178.862.R | G178.862.R |
| E193.410.R | G193.410.R |
| E182.476.R | G182.476.R |

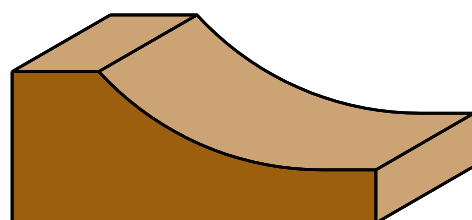

E178.862.R

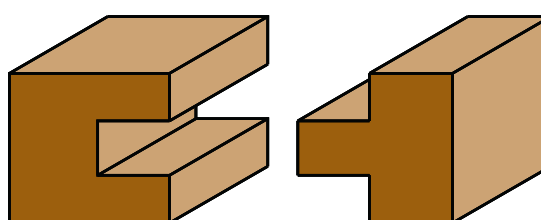

E193.410.R

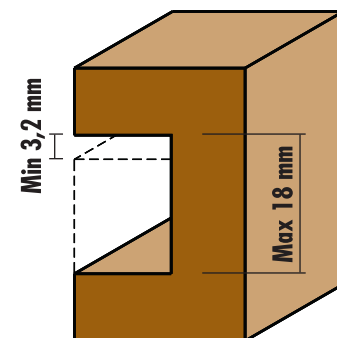

E182.476.R

Scale 1:1

DISPLAY UNITS

BASE
1 modular panel

Little display unit, suitable for those who mean to start with a sufficient choice for a small number of customers.
Dimensions (cm): 110 (L) x 90 (H) x 30 (P)

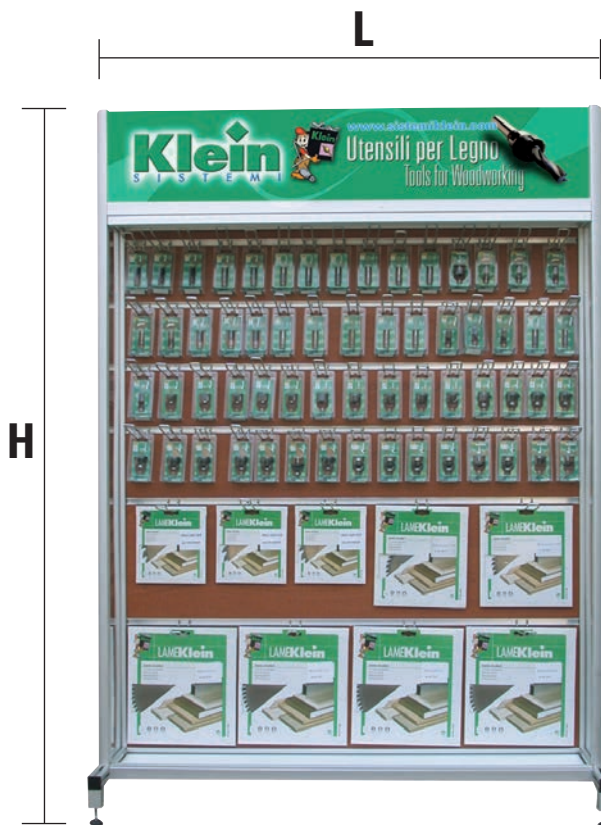

STANDARD
2 modular panels

Consisting of two "Basic model" displays, can be composed according to the customer's requirements. It is suitable for anyone who wants to have a good choice of items in view to improve his offer.
Dimensions (cm): 110 (L) x 145 (H) x 36 (P)

PROFESSIONAL
3 modular panels

Large display, consisting of three "Basic model" units allows you to show a wide choice of items. By the combination of two or more displays, you can equip a wall and meet all professional woodworkers' requirements.
Dimensions (cm): 110 (L) x 200 (H) x 36 (P)

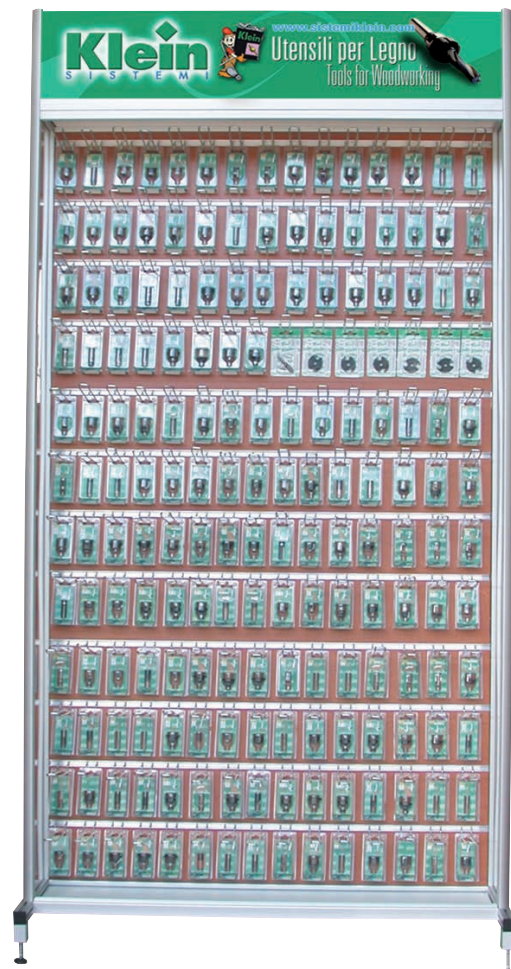

Router bits for wood, chipboards and solid surface materials



3

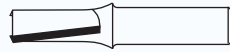

HW ROUTER BITS WITH NEGATIVE AXIAL ANGLE Z=2
Page 3.05



HW STRAIGHT PLUNGE BITS Z=1
Page 3.05



HW STRAIGHT PLUNGE BITS WITH BALL BEARING GUIDE Z=2
Page 3.05



HW FACE-INLAY BITS WITH BALL BEARING GUIDE Z=2
Page 3.05



HW FLUSH TRIM BITS WITH BALL BEARING GUIDE Z=2
Page 3.06



HW FLUSH TRIM BITS WITH UPPER BALL BEARING GUIDE Z=2
Page 3.06



HW TOPMOUNT ROUTER BITS Z=2
Page 3.06



HW BEVEL HOLE ROUTER BITS Z=3
Page 3.06



HW BEVEL UNDERMOUNT BITS WITH BALL BEARING GUIDE Z=2
Page 3.06

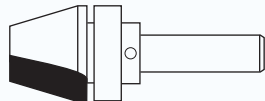

HW TOPMOUNT COUNTERTOP BITS WITH UPPER BALL BEARING GUIDE Z=2
Page 3.06

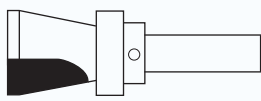

HW TOPMOUNT COUNTERTOP BITS WITH UPPER BALL BEARING GUIDE Z=2
Page 3.07



HW ROUNDOVER BITS WITH BALL BEARING GUIDE Z=2
Page 3.07

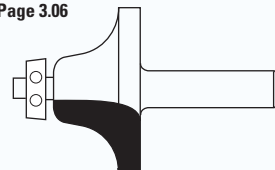

HW OGEE BITS WITH BALL BEARING GUIDE Z=2
Page 3.07



HW COUNTER-TOP BITS WITH BALL BEARING GUIDE Z=2
Page 3.07

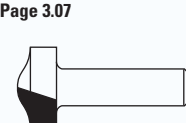

HW CORNER TOP BITS Z=2
Page 3.07

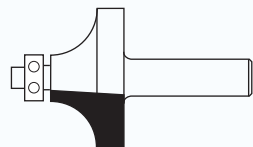

HW CORNER ROUNDING BITS WITH BALL BEARING GUIDE Z=2
Page 3.08

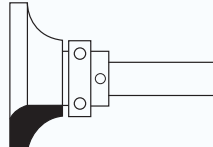

HW ROUNDING-UNDER BITS WITH UPPER BALL BEARING GUIDE Z=2
Page 3.08

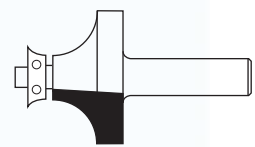

HW CORNER-ROUNDING BITS WITH BALL BEARING GUIDE Z=2
Page 3.08



HW EDGE FACE COVE BITS WITH BALL BEARING GUIDE Z=2
Page 3.08



HW UPSTAND BITS Z=2
Page 3.08

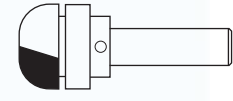

HW COVE BITS WITH UPPER BALL BEARING GUIDE Z=2
Page 3.09



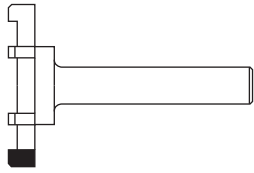

HW BOWL AND COUNTERTOP TRIM BITS Z=2
Page 3.09



HW PROFILE BITS Z=2
Page 3.09

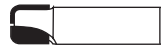

HW PROFILE BITS Z=2
Page 3.09

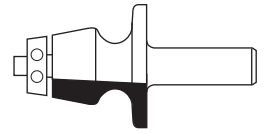

HW UNDERMOUNT PROFILE BOWL BITS WITH BALL BEARING GUIDE Z=2
Page 3.09

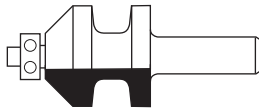

HW BEVEL HOB BITS WITH BALL BEARING GUIDE Z=2
Page 3.09

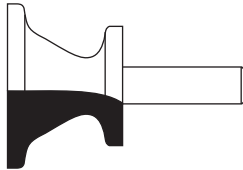

HW BEADING BITS Z=2
Page 3.10



HW TRIPLE BEADING BITS WITH BALL BEARING GUIDE Z=2
Page 3.10

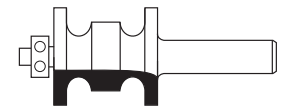

HW DOUBLE BEADING BITS WITH BALL BEARING GUIDE Z=2
Page 3.10

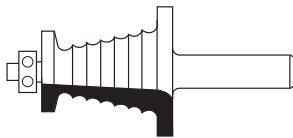

HW MULTI BEADING BITS WITH BALL BEARING GUIDE Z=2
Page 3.10

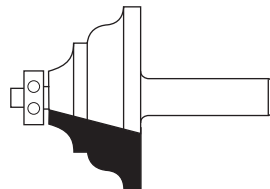

HW EDGE MOULDING BITS WITH BALL BEARING GUIDE Z=2
Page 3.10

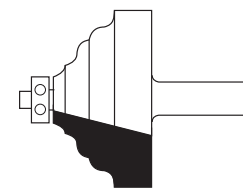

HW EDGE MOULDING BITS WITH BALL BEARING GUIDE Z=2
Page 3.11

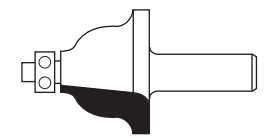

HW WAVY EDGE BITS WITH BALL BEARING GUIDE Z=2
Page 3.11

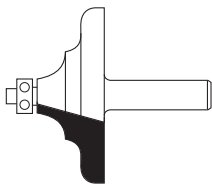

HW EDGE MOULDING BITS WITH BALL BEARING GUIDE Z=2
Page 3.11

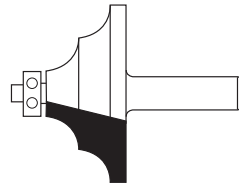

HW EDGE MOULDING BITS WITH BALL BEARING GUIDE Z=2
Page 3.11

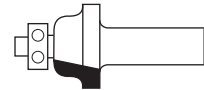

HW ROMAN OGEE BITS WITH BALL BEARING GUIDE Z=2
Page 3.11

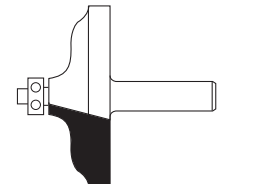

HW EDGE MOULDING BITS WITH BALL BEARING GUIDE Z=2
Page 3.12

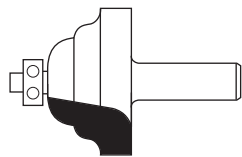

HW EDGE MOULDING BITS WITH BALL BEARING GUIDE Z=2
Page 3.12

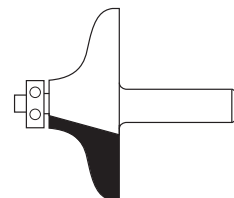

HW EDGE MOULDING BITS WITH BALL BEARING GUIDE Z=2
Page 3.12

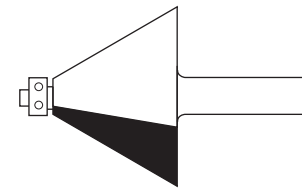

HW BEVEL BITS WITH BALL BEARING GUIDE Z=2
Page 3.12

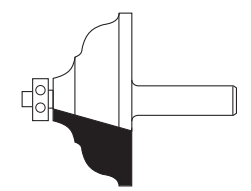

HW EDGE MOULDING BITS WITH BALL BEARING GUIDE Z=2
Page 3.12

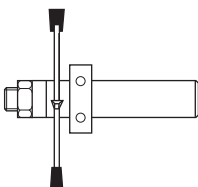

HW ROUTER BITS FOR SINK REPAIRING
Page 3.13

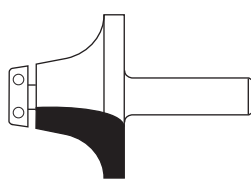

HW ROUNDING OVER UNDERMOUNT BOWL BITS WITH BALL BEARING GUIDE Z=2
Page 3.13



HW ROUNDING OVER UNDERMOUNT BOWL BITS WITH BALL BEARING GUIDE Z=2
Page 3.13



INSERT FLUSH TRIM BITS Z=2
Page 3.13



INSERT FLUSH TRIM BITS Z=2
Page 3.13



HW/HS STRAIGHT PLUNGE CUTTING BITS FOR "ELU" Z=2
Page 3.14



HW STRAIGHT PLUNGE CUTTING BITS FOR "ELU" Z=2
Page 3.14



HW STRAIGHT PLUNGE CUTTING BITS FOR "SCHEER" Z=2
Page 3.14



HW STRAIGHT PLUNGE CUTTING BITS
FOR "SCHEER" Z=2
Page 3.14

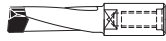

HW DRILL BITS FOR "FESTOOL"
MACHINES Z=2
Page 3.15

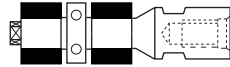

HW FLUSH TRIMMING BITS
WITH BALL BEARING GUIDE Z=2
Page 3.15

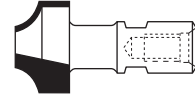

HW RADIUS BITS Z=2
Page 3.15

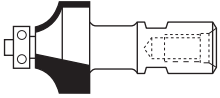

HW RADIUS BITS WITH
BALL BEARING GUIDE Z=2
Page 3.15



HW RADIUS BITS Z=2
Page 3.16



HW RADIUS BITS Z=2
Page 3.16

ROUTER BITS FOR WORKING ON SOLID SURFACE MATERIALS

The series of tools on page 3.05 to page 3.13 have been specifically designed for working Solid Surface materials (**CORIAN®**). The type of raw material, cutting angles and components used in manufacturing the router bits shown here have been carefully selected to get the best finishing. Special router bits can be manufactured on request.



HW ROUTER BITS WITH NEGATIVE AXIAL ANGLE Z=2

ART. E300 - G300

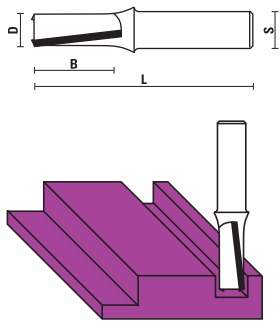

| S Ø 12 | S Ø 12,7 (1/2") | D | B | L |
|------------|-----------------|------|----|-------|
| E300.095.R | G300.095.R | 9,5 | 50 | 70 |
| E300.127.R | G300.127.R | 12,7 | 32 | 73 |
| E300.128.R | G300.128.R | 12,7 | 38 | 79 |
| E300.129.R | G300.129.R | 12,7 | 50 | 107,5 |

HW STRAIGHT PLUNGE BITS Z=1

ART. E301 - G301

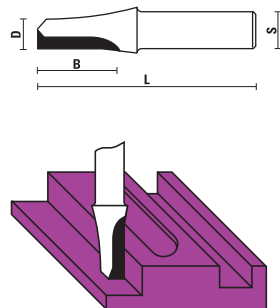

| S Ø 12 | S Ø 12,7 (1/2") | D | B | L |
|------------|-----------------|-----|----|----|
| E301.095.R | G301.095.R | 9,5 | 25 | 70 |

HW STRAIGHT PLUNGE BITS WITH BALL BEARING GUIDE Z=2

ART. E302 - G302

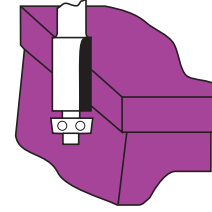
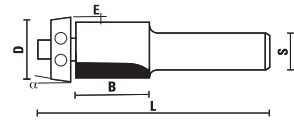

5° ball bearing with Delrin® ring

| S Ø 12 | S Ø 12,7 (1/2") | D | B | α | E | L |
|------------|-----------------|----|----|----|-----|------|
| E302.190.R | G302.190.R | 19 | 25 | 5° | 1,6 | 82,5 |



| S Ø 12 | S Ø 12,7 (1/2") | D | B | L | α |
|------------|-----------------|----|------|----|----|
| E302.191.R | G302.191.R | 19 | 25,4 | 80 | 0° |



HW FACE-INLAY BITS WITH BALL BEARING GUIDE Z=2

ART. E305 - GE306 - E307

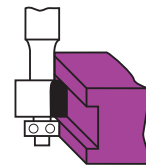
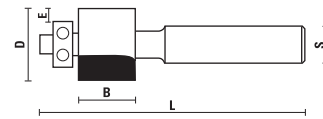

| S Ø 12 | D | B | L | E | |
|------------|-------------|----|------|----|-----|
| E305.064.R | Selling out | 22 | 6,4 | 76 | 4,8 |
| E305.095.R | Selling out | 22 | 9,5 | 78 | 4,8 |
| E305.127.R | | 22 | 12,7 | 82 | 4,8 |
| E305.190.R | Selling out | 22 | 19 | 88 | 4,8 |



| S Ø 12 | D | B | L | E | |
|------------|---|----|------|----|-----|
| E306.064.R | | 22 | 6,4 | 76 | 3,2 |
| E306.095.R | | 22 | 9,5 | 78 | 3,2 |
| E306.127.R | | 22 | 12,7 | 82 | 3,2 |
| E306.190.R | | 22 | 19 | 88 | 3,2 |



| S Ø 12 | D | B | L | E | |
|------------|---|----|------|----|-----|
| E307.095.R | | 22 | 9,5 | 79 | 1,6 |
| E307.127.R | | 22 | 12,7 | 82 | 1,6 |
| E307.190.R | | 22 | 19 | 82 | 1,6 |



HW FLUSH TRIM BITS WITH BALL BEARING GUIDE Z=2

ART. E310 - G310

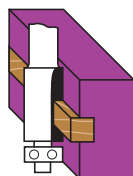
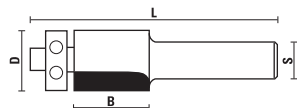

| S Ø 12 | S Ø 12,7 (1/2") | D | B | L |
|------------|-----------------|----|----|----|
| E310.190.R | G310.190.R | 19 | 25 | 82 |



Z050.101.N



Z053.002.N



Z051.004.R

HW FLUSH TRIM BITS WITH UPPER BALL BEARING GUIDE Z=2

ART. E312 - G312

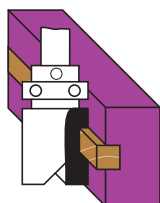
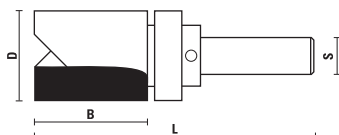

| S Ø 12 | S Ø 12,7 (1/2") | D | B | L |
|------------|-----------------|------|----|----|
| E312.286.R | G312.286.R | 28,6 | 38 | 92 |



Z050.015.N



Z058.003.N



Z051.005.R

HW TOPMOUNT ROUTER BITS Z=2

ART. E315

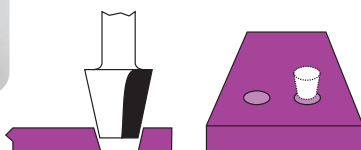
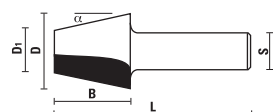

| S Ø 12 | D | D ₁ | B | L | α |
|------------|----|----------------|----|------|-----|
| E315.240.R | 23 | 12,3 | 25 | 63,1 | 15° |
| E315.340.R | 34 | 23,3 | 25 | 63,1 | 15° |
| E315.450.R | 45 | 34,3 | 25 | 63,1 | 15° |

HW BEVEL HOLE ROUTER BITS Z=3

ART. E315

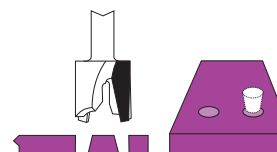
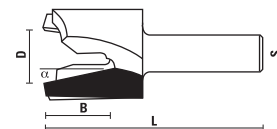

| S Ø 12 | D | B | L | α |
|------------|----|----|----|-----|
| E315.730.R | 23 | 20 | 72 | 15° |
| E315.840.R | 34 | 20 | 72 | 15° |
| E315.950.R | 45 | 20 | 72 | 15° |

HW BEVEL UNDERMOUNT BITS WITH BALL BEARING GUIDE Z=2

ART. E316 - G316

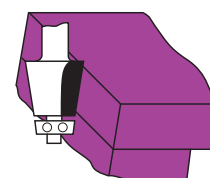
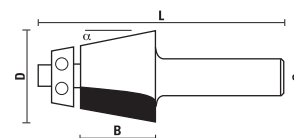

12° ball bearing with Delrin® ring

| S Ø 12 | S Ø 12,7 (1/2") | D | B | L | α |
|------------|-----------------|----|----|----|-----|
| E316.320.R | G316.320.R | 32 | 25 | 81 | 12° |



Z050.102.N



Z053.002.N



Z051.004.R

| S Ø 12 | S Ø 12,7 (1/2") | D | B | L | α |
|------------|-----------------|----|----|----|-----|
| E316.390.R | G316.390.R | 39 | 32 | 78 | 12° |



Z050.106.N



Z053.002.N



Z051.007.R

HW TOPMOUNT COUNTERTOP BITS WITH UPPER BALL BEARING GUIDE Z=2

ART. E317 - G317

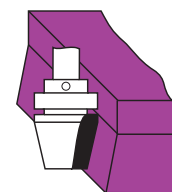
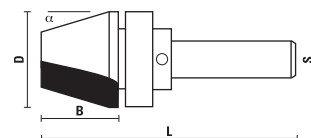

| S Ø 12 | S Ø 12,7 (1/2") | D | B | L | α |
|------------|-----------------|------|----|----|-----|
| E317.286.R | G317.286.R | 28,6 | 25 | 78 | 12° |



Z050.015.N



Z058.003.N



Z051.005.R

HW TOPMOUNT COUNTERTOP BITS WITH UPPER BALL BEARING GUIDE Z=2

ART. E321

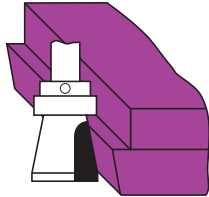
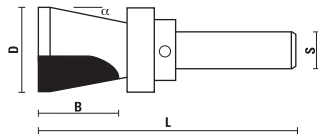

| S Ø 12 | D | B | L | α |
|------------|------|----|----|-----|
| E321.286.R | 28,6 | 26 | 79 | 12° |



Z050.015.N



Z058.003.N



Z051.005.R

HW ROUNDROVER BITS WITH BALL BEARING GUIDE Z=2

ART. E325 - G325

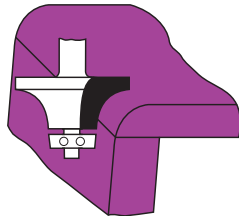
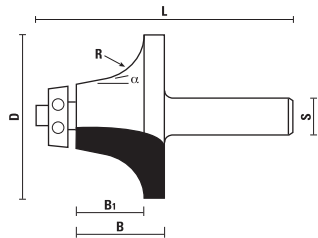

18° ball bearing with Delrin® ring

| S Ø 12 | S Ø 12,7 (1/2") | D | B | B1 | L | R | α |
|------------|-----------------|----|----|----|----|------|-----|
| E325.540.R | G325.540.R | 54 | 25 | 19 | 79 | 12,7 | 18° |
| E325.570.R | G325.570.R | 57 | 32 | 25 | 83 | 14 | 18° |



Z050.102.N



Z053.002.N



Z051.004.R

HW OGEE BITS WITH BALL BEARING GUIDE Z=2

ART. E326 - G326

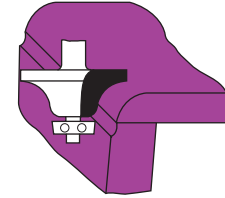
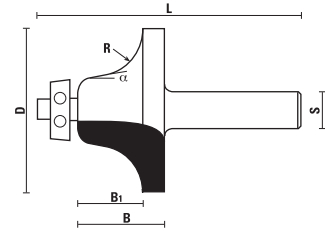

15° ball bearing with Delrin® ring

| S Ø 12 | S Ø 12,7 (1/2") | D | B | B1 | L | R | α |
|------------|-----------------|----|----|----|----|------|-----|
| E326.550.R | G326.550.R | 55 | 25 | 19 | 75 | 12,7 | 15° |
| E326.610.R | | 61 | 32 | 25 | 86 | 14 | 15° |



Z050.102.N



Z053.002.N



Z051.004.R

HW COUNTER-TOP BITS WITH BALL BEARING GUIDE Z=2

ART. E330 - G330

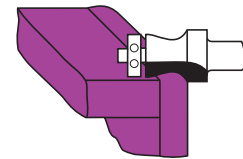
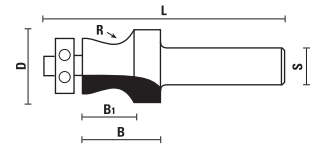

For anti-drip profile on washbasin

| S Ø 12 | S Ø 12,7 (1/2") | D | B | B1 | L | R |
|------------|-----------------|----|----|----|----|---|
| E330.220.R | G330.220.R | 25 | 22 | 16 | 79 | 8 |
| E330.290.R | G330.290.R | 25 | 29 | 24 | 85 | 8 |



Z050.101.N



Z053.002.N



Z051.004.R

HW CORNER TOP BITS Z=2

ART. E333 - G333

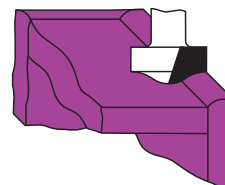
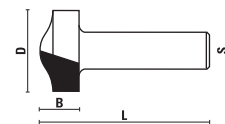

| S Ø 12 | S Ø 12,7 (1/2") | D | B | L |
|------------|-----------------|------|----|----|
| E333.254.R | G333.254.R | 25,4 | 13 | 54 |

HW CORNER ROUNDING BITS WITH BALL BEARING GUIDE Z=2

ART. E334 - G334

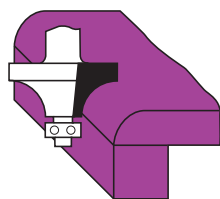
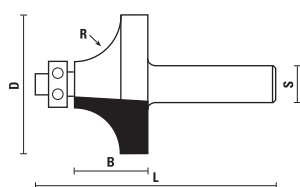
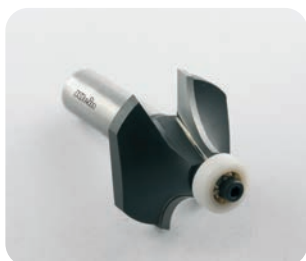

| S Ø 12 | S Ø 12,7 (1/2") | D | B | L | R |
|------------|-----------------|------|------|----|------|
| E334.254.R | G334.254.R | 25,4 | 13 | 62 | 6,4 |
| E334.286.R | G334.286.R | 28,6 | 13,5 | 61 | 8 |
| E334.380.R | G334.380.R | 38 | 19 | 65 | 12,7 |
| E334.510.R | G334.510.R | 51 | 25 | 72 | 19 |



Z050.100.N



Z053.002.N



Z051.002.R

HW ROUNDING-UNDER BITS WITH UPPER BALL BEARING GUIDE Z=2

ART. E335 - G335

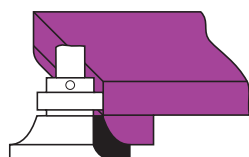
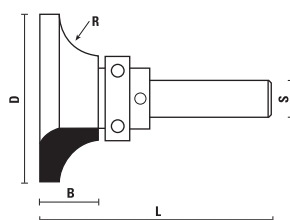

For bottom rounding

| S Ø 12 | S Ø 12,7 (1/2") | D | B | L | R |
|-------------|-----------------|----|----|----|------|
| E335.540.R | G335.540.R | 54 | 20 | 73 | 12,7 |
| E335.670.R* | G335.670.R | 67 | 25 | 77 | 19 |

*Selling out



Z050.104.N



Z058.003.N



Z051.005.R

HW CORNER-ROUNDING BITS WITH BALL BEARING GUIDE Z=2

ART. E336 - G336

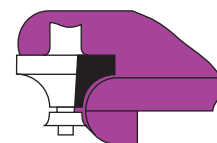
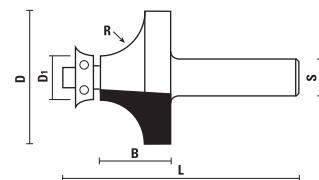
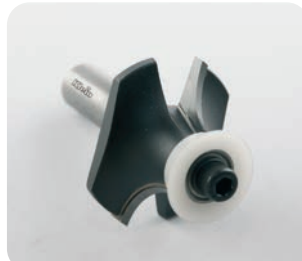

R=12,7 ball bearing

| S Ø 12 | S Ø 12,7 (1/2") | D | D1 | R | B | L |
|------------|-----------------|----|----|----|----|----|
| E336.410.R | G336.410.R | 41 | 16 | 13 | 19 | 68 |



Z050.105.N



Z053.002.N



Z051.004.R

| S Ø 12 | S Ø 12,7 (1/2") | D | D1 | R | B | L |
|------------|-----------------|----|----|----|----|----|
| E336.540.R | G336.540.R | 54 | 16 | 19 | 25 | 74 |



Z050.113.N



Z053.002.N



Z051.004.R

HW EDGE FACE COVE BITS WITH BALL BEARING GUIDE Z=2

ART. E338

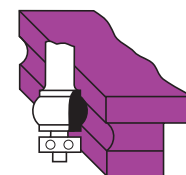
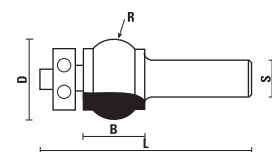

| S Ø 12 | D | B | L | R | |
|------------|-------------|------|----|----|-----|
| E338.255.R | Selling out | 25,5 | 16 | 67 | 7,9 |



Z050.101.N



Z053.002.N



Z051.004.R

HW UPSTAND BITS Z=2

ART. E340 - G340

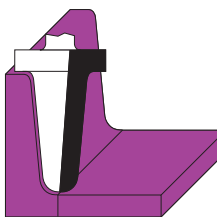
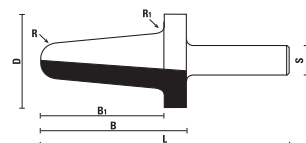

| S Ø 12 | S Ø 12,7 (1/2") | D | B | B1 | R | R1 | L |
|-------------|-----------------|----|----|----|---|----|----|
| E340.390.R* | | 39 | 40 | 30 | 6 | 3 | 78 |
| E340.391.R | G340.391.R | 39 | 55 | 45 | 6 | 3 | 93 |

*Selling out

HW COVE BITS WITH UPPER BALL BEARING GUIDE Z=2

ART. E342 - G342

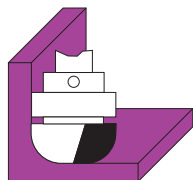
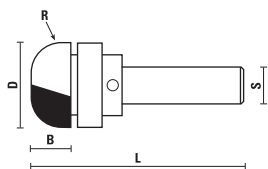

| S Ø 12 | S Ø 12,7 (1/2") | D | B | R | L |
|------------|-----------------|------|----|----|----|
| E342.286.R | G342.286.R | 28,6 | 13 | 10 | 73 |



Z050.104.N



Z058.003.N



Z051.005.R

HW BOWL AND COUNTERTOP TRIM BITS Z=2

ART. E350 - G350

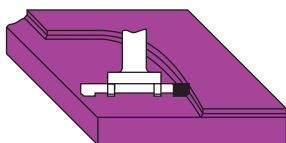
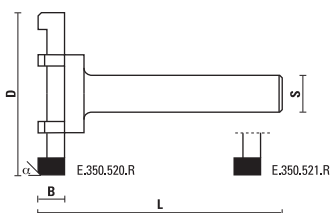

| S Ø 12 | S Ø 12,7 (1/2") | D | B | L | Z | α |
|------------|-----------------|----|-----|----|---|---------|
| E350.520.R | G350.520.R | 52 | 6,5 | 83 | 6 | 0,5x45° |
| E350.521.R | G350.521.R | 52 | 6,5 | 83 | 6 | 0° |

HW PROFILE BITS Z=2

ART. E360

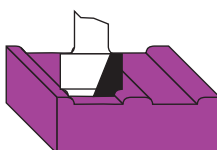
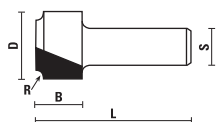

| S Ø 12 | D | B | R | L |
|------------|------|----|---|----|
| E360.246.R | 24,6 | 16 | 2 | 60 |

HW PROFILE BITS Z=2

ART. E361

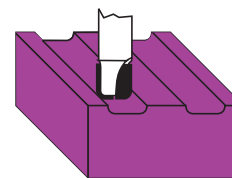
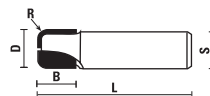

| S Ø 12 | D | B | R | L |
|------------|------|----|-----|----|
| E361.127.R | 12,7 | 13 | 3,2 | 51 |
| E361.160.R | 16 | 13 | 3,2 | 51 |
| E361.190.R | 19 | 13 | 3,2 | 51 |
| E361.254.R | 25,4 | 13 | 3,2 | 51 |

HW UNDERMOUNT PROFILE BOWL BITS WITH BALL BEARING GUIDE Z=2

ART. E362

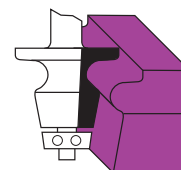
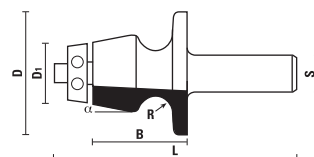

10° ball bearing with Delrin® ring

| S Ø 12 | D | D1 | B | R | L | α | |
|------------|-------------|----|----|----|-----|----|-----|
| E362.420.R | Selling out | 42 | 22 | 33 | 6,4 | 84 | 10° |



Z050.102.N



Z053.002.N



Z051.004.R

HW BEVEL HOB BITS WITH BALL BEARING GUIDE Z=2

ART. E363

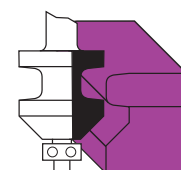
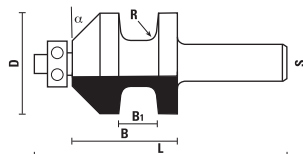

| S Ø 12 | D | B | B1 | R | L | α | |
|------------|-------------|----|------|-------|-----|----|-----|
| E363.350.R | Selling out | 35 | 36,5 | 12-13 | 3,2 | 89 | 45° |



Z050.011.N



Z054.003.N



Z051.004.R

HW BEADING BITS Z=2

ART. E364

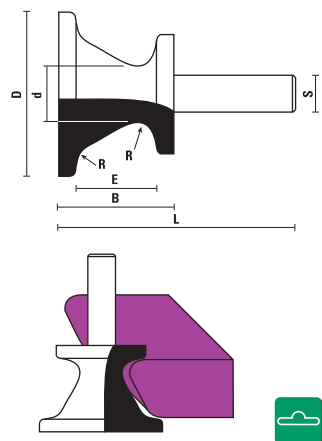



| S Ø 12 | D | d | B | E | R | L |
|------------------------|----|----|----|-------|-----|-----|
| E364.370.R Selling out | 37 | 16 | 25 | 12-13 | 4,8 | 84 |
| E364.540.R Selling out | 54 | 19 | 37 | 24-26 | 6,4 | 96 |
| E364.710.R Selling out | 71 | 22 | 50 | 36-39 | 9,5 | 109 |

HW TRIPLE BEADING BITS WITH BALL BEARING GUIDE Z=2

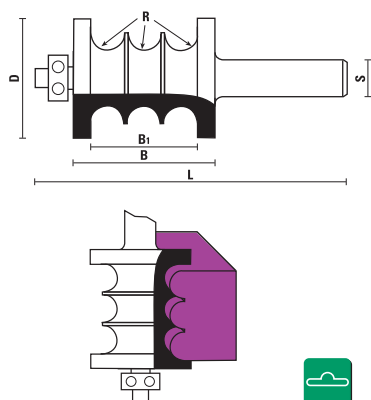
ART. E365



| S Ø 12 | D | B | B1 | R | L |
|------------------------|----|----|----|---|-----|
| E365.410.R Selling out | 41 | 51 | 39 | 6 | 101 |



 Z050.011.N
  Z053.002.N
  Z051.004.R

HW DOUBLE BEADING BITS WITH BALL BEARING GUIDE Z=2

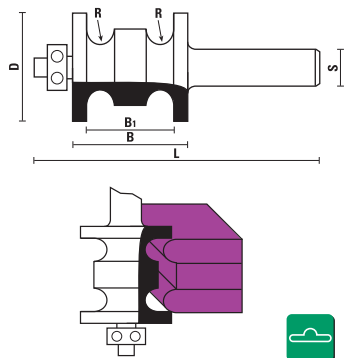
ART. E366



| S Ø 12 | D | B | B1 | R | L |
|------------------------|----|----|----|---|----|
| E366.380.R Selling out | 38 | 51 | 38 | 6 | 79 |



 Z050.011.N
  Z054.003.N
  Z051.004.R

HW MULTI BEADING BITS WITH BALL BEARING GUIDE Z=2

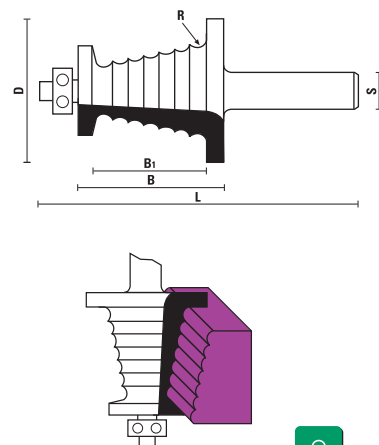
ART. E367



| S Ø 12 | D | B | B1 | R | L |
|------------------------|----|----|----|---|----|
| E367.510.R Selling out | 51 | 51 | 38 | 3 | 99 |



 Z050.011.N
  Z053.002.N
  Z051.002.R

HW EDGE Moulding BITS WITH BALL BEARING GUIDE Z=2

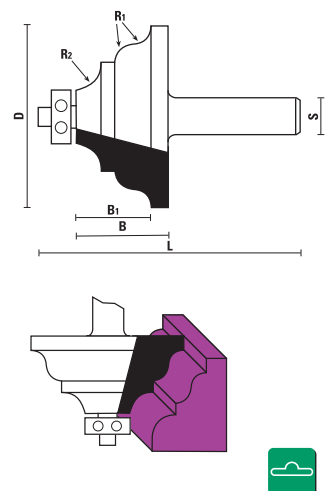
ART. E368



| S Ø 12 | D | B | B1 | R1 | R2 | L |
|------------------------|------|----|----|-----|-----|----|
| E368.635.R Selling out | 63,5 | 32 | 27 | 6,4 | 9,5 | 81 |

 Z050.011.N
  Z053.002.N
  Z051.004.R

HW EDGE MOULDING BITS WITH BALL BEARING GUIDE Z=2

ART. E370

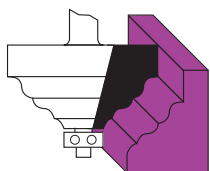
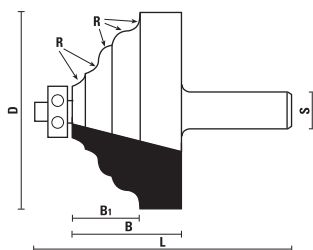

| S Ø 12 | D | B | B1 | R | L |
|------------------------|----|----|----|-----|----|
| E370.700.R Selling out | 70 | 40 | 33 | 4,8 | 87 |



Z050.101.N



Z053.002.N



Z051.004.R

HW WAVY EDGE BITS WITH BALL BEARING GUIDE Z=2

ART. E371

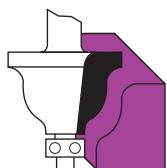
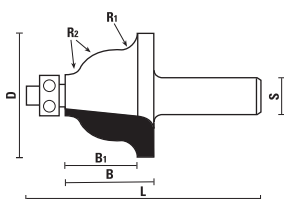

| S Ø 12 | D | B | B1 | R1 | R2 | L |
|------------------------|----|----|----|----|----|------|
| E371.440.R Selling out | 44 | 32 | 25 | 6 | 13 | 82,5 |



Z050.100.N



Z053.002.N



Z051.002.R

HW EDGE MOULDING BITS WITH BALL BEARING GUIDE Z=2

ART. E373

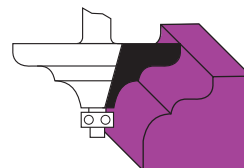
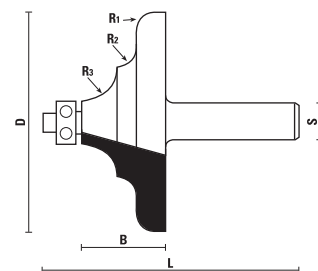

| S Ø 12 | D | R1 | R2 | R3 | B | L |
|------------------------|----|-----|----|------|----|----|
| E373.760.R Selling out | 76 | 6,4 | 6 | 12,7 | 30 | 78 |



Z050.100.N



Z053.002.N



Z051.002.R

HW EDGE MOULDING BITS WITH BALL BEARING GUIDE Z=2

ART. E374

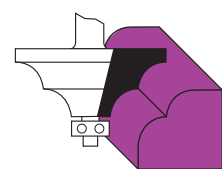
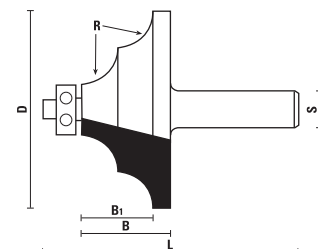

| S Ø 12 | D | B | B1 | R | L |
|------------------------|----|----|----|------|------|
| E374.700.R Selling out | 70 | 32 | 25 | 12,7 | 82,5 |



Z050.101.N



Z053.002.N



Z051.004.R

HW ROMAN OGEE BITS WITH BALL BEARING GUIDE Z=2

ART. E375

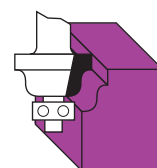
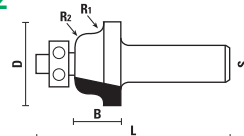

| S Ø 12 | D | B | R1 | R2 | L |
|------------|------|----|-----|----|------|
| E375.286.R | 28,6 | 16 | 3,2 | 4 | 63,5 |



Z050.100.N



Z053.002.N



Z051.002.R

HW EDGE MOULDING BITS WITH BALL BEARING GUIDE Z=2

ART. E376

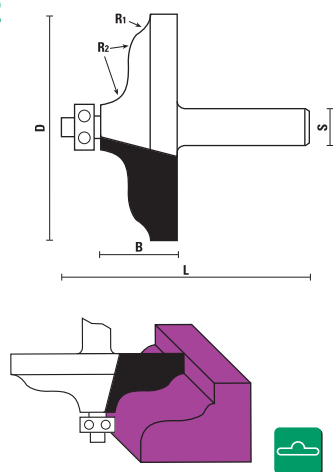

| S Ø 12 | D | B | R1 | R2 | L |
|------------------------|----|----|-----|----|------|
| E376.790.R Selling out | 79 | 28 | 5,2 | 9 | 74,5 |



HW EDGE MOULDING BITS WITH BALL BEARING GUIDE Z=2

ART. E377

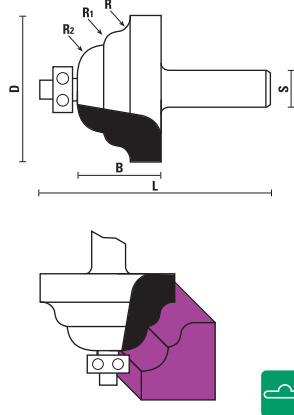

| S Ø 12 | D | R | R1 | R2 | B | L |
|------------------------|----|-----|-----|-----|----|------|
| E377.510.R Selling out | 51 | 4,4 | 4,4 | 9,5 | 28 | 82,5 |



HW EDGE MOULDING BITS WITH BALL BEARING GUIDE Z=2

ART. E378

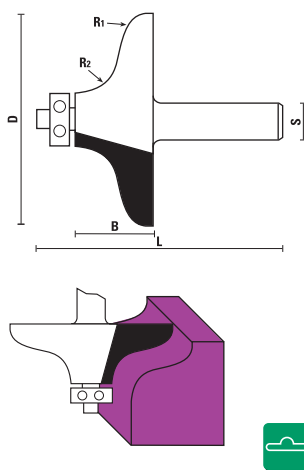

| S Ø 12 | D | B | R1 | R2 | L |
|------------------------|----|----|----|------|----|
| E378.760.R Selling out | 76 | 28 | 8 | 12,7 | 79 |



HW BEVEL BITS WITH BALL BEARING GUIDE Z=2

ART. E380 - G380

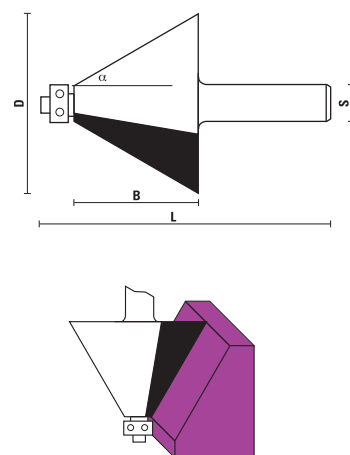
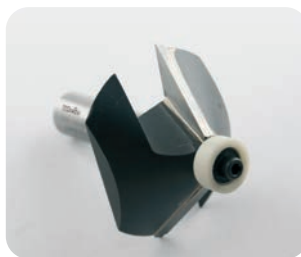

| S Ø 12 | S Ø 12,7 (1/2") | D | B | L | α |
|------------|-----------------|----|----|----|-----|
| E380.510.R | G380.510.R | 51 | 19 | 67 | 45° |
| E380.640.R | G380.640.R | 64 | 44 | 93 | 30° |



HW EDGE MOULDING BITS WITH BALL BEARING GUIDE Z=2

ART. E381

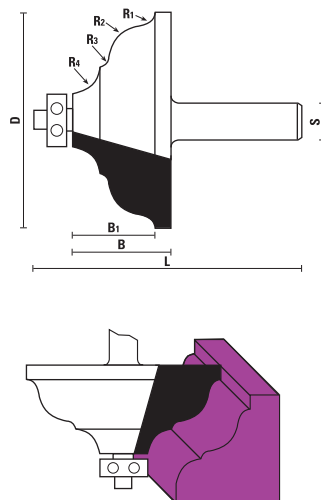

| S Ø 12 | D | B | B1 | R1 | R2 | R3 | R4 | L |
|------------------------|----|------|----|-----|------|-----|-----|----|
| E381.760.R Selling out | 76 | 34,9 | 29 | 4,8 | 12,7 | 3,2 | 9,5 | 84 |



HW CIRCULAR SAWBLADES

ART. MES

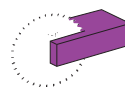

See also Art. MES section 12 page 12.34

HW ROUTER BITS FOR SINK REPAIRING

ART. E382 - G382

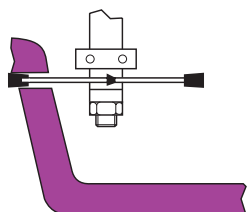
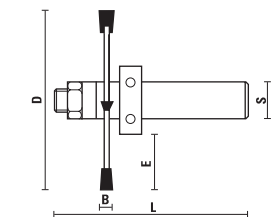

| S Ø 12 | S Ø 12,7 (1/2") | D | E | B | L | Z |
|------------|-----------------|----|------|---|----|---|
| E382.670.R | G382.670.R | 80 | 25,7 | 6 | 96 | 4 |

Spare parts

Spare arbor

E117.120.N

Spare cutter D = Ø 80/Ø 8 Z=4

C118.980.R



Z050.112.N

HW ROUNDING OVER UNDERMOUNT BOWL BITS WITH BALL BEARING GUIDE Z=2

ART. E383 - G383

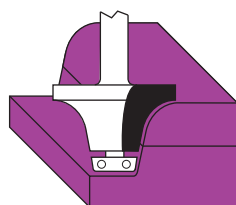
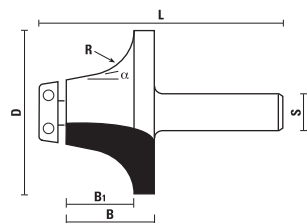
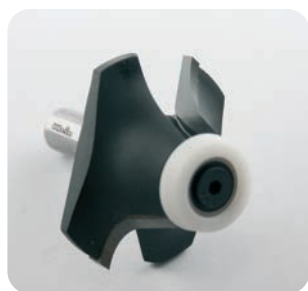

17° ball bearing with Delrin® ring

| S Ø 12 | S Ø 12,7 (1/2") | D | B | B1 | R | L | α |
|------------|-----------------|----|------|------|------|------|-----|
| E383.450.R | G383.450.R | 45 | 17,5 | 13,5 | 9,5 | 63,5 | 17° |
| E383.510.R | G383.510.R | 51 | 17,5 | 13,5 | 12,7 | 63,5 | 17° |
| E383.540.R | G383.540.R | 54 | 25 | 20 | 12,7 | 73 | 17° |
| E383.570.R | G383.570.R | 57 | 25 | 20 | 19 | 76 | 17° |



Z050.120.N

HW ROUNDING OVER UNDERMOUNT BOWL BITS WITH BALL BEARING GUIDE Z=2

ART. E384

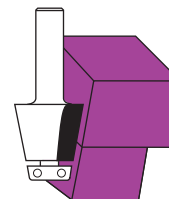
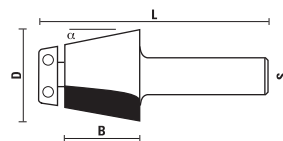

12° ball bearing with Delrin® ring

| S Ø 12 | D | B | L | α |
|------------|----|----|----|-----|
| E384.320.R | 32 | 25 | 76 | 12° |



Z050.102.N

INSERT FLUSH TRIM BITS Z=2

ART. W138

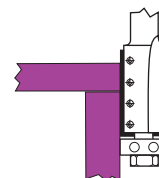
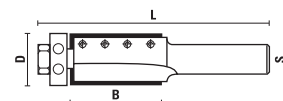

- HW knives with "Kawedur" coating
- For CORIAN®
- Ball bearing with Delrin® ring

| S Ø 12 | D | B | L |
|------------|----|----|----|
| W138.190.R | 19 | 30 | 82 |



Z050.111.N



Z055.230.N



Z051.101.N

INSERT FLUSH TRIM BITS Z=2

ART. W138

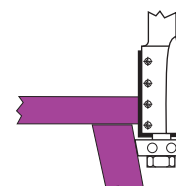
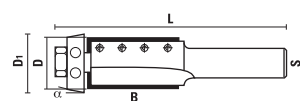

- HW knives with "Kawedur" coating
- For CORIAN®
- 11° ball bearing with Delrin® ring

| S Ø 12 | D | D1 | B | L | α |
|------------|----|----|----|----|-----|
| W138.220.R | 19 | 22 | 30 | 82 | 11° |



Z050.110.N



Z055.230.N



Z051.101.N

See also section 9 page 9.07 for more details

HW/HS STRAIGHT PLUNGE CUTTING BITS FOR "ELU" Z=2

ART. F101 - F202

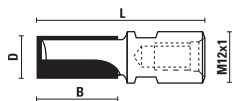

| S = M12x1 | D | B | L | Mat. |
|------------|----|----|----|------|
| F101.060.R | 6 | 18 | 60 | HW |
| F101.070.R | 7 | 20 | 60 | HW |
| F101.080.R | 8 | 25 | 60 | HW |
| F101.100.R | 10 | 25 | 60 | HW |
| F101.120.R | 12 | 25 | 60 | HW |
| F101.140.R | 14 | 25 | 60 | HW |
| F101.150.R | 15 | 25 | 60 | HW |
| F101.160.R | 16 | 25 | 60 | HW |
| F101.180.R | 18 | 25 | 60 | HW |
| F101.200.R | 20 | 25 | 60 | HW |
| F101.220.R | 22 | 25 | 60 | HW |
| F101.240.R | 24 | 25 | 60 | HW |
| F101.250.R | 25 | 25 | 60 | HW |
| F101.300.R | 30 | 25 | 60 | HW |

HW STRAIGHT PLUNGE CUTTING BITS FOR "ELU" Z=2

ART. F103 - F104 - F105



Long execution

| S = M12x1 | D | B | L |
|------------|----|----|----|
| F103.080.R | 8 | 35 | 67 |
| F103.100.R | 10 | 35 | 67 |
| F103.120.R | 12 | 35 | 67 |
| F103.140.R | 14 | 35 | 67 |
| F103.160.R | 16 | 35 | 67 |
| F103.180.R | 18 | 35 | 67 |
| F103.200.R | 20 | 35 | 67 |
| F103.220.R | 22 | 35 | 67 |
| F104.120.R | 12 | 45 | 77 |
| F104.150.R | 15 | 45 | 77 |
| F104.160.R | 16 | 45 | 77 |
| F104.161.R | 16 | 50 | 82 |
| F104.180.R | 18 | 45 | 77 |
| F104.200.R | 20 | 45 | 77 |
| F105.140.R | 14 | 60 | 92 |
| F105.160.R | 16 | 60 | 92 |
| F105.180.R | 18 | 60 | 92 |
| F105.200.R | 20 | 60 | 92 |
| F105.220.R | 22 | 60 | 92 |

HW STRAIGHT PLUNGE CUTTING BITS FOR "SCHEER" Z=2

ART. F152 - F153

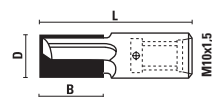

| S = M10x1,5 | D | B | L |
|-------------|----|----|----|
| F152.040.R | 4 | 10 | 55 |
| F152.050.R | 5 | 12 | 55 |
| F152.060.R | 6 | 14 | 55 |
| F152.080.R | 8 | 20 | 55 |
| F152.100.R | 10 | 22 | 55 |
| F152.120.R | 12 | 22 | 55 |
| F152.140.R | 14 | 25 | 55 |
| F152.150.R | 15 | 25 | 55 |
| F152.160.R | 16 | 25 | 55 |
| F152.180.R | 18 | 25 | 55 |
| F152.200.R | 20 | 25 | 55 |
| F152.220.R | 22 | 25 | 55 |
| F152.240.R | 24 | 25 | 55 |
| F152.250.R | 25 | 25 | 55 |
| F152.300.R | 30 | 25 | 55 |

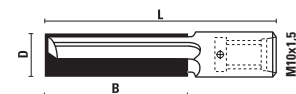

Long execution

| S = M10x1,5 | D | B | L |
|-------------|----|----|----|
| F153.060.R | 6 | 30 | 65 |
| F153.080.R | 8 | 35 | 70 |
| F153.100.R | 10 | 35 | 70 |
| F153.120.R | 12 | 35 | 70 |
| F153.140.R | 14 | 35 | 70 |
| F153.160.R | 16 | 45 | 75 |
| F153.180.R | 18 | 45 | 75 |
| F153.200.R | 20 | 45 | 75 |
| F153.220.R | 22 | 45 | 75 |

HW DRILL BITS FOR "FESTOOL" MACHINES Z=2

ART. F160

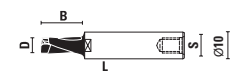

F160.040.R

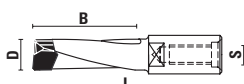

F160.050/100.R

- To be used on Festool® joining machines "Domino DF500"
- Suitable for creating dowel cross-cut for making "Domino®" joints for frames, drawers, cabinets and furniture



| S = M6x0,75 | D | B | L |
|------------------|----|----|----|
| F160.040.R ▲ NEW | 4 | 11 | 38 |
| F160.050.R | 5 | 20 | 49 |
| F160.060.R | 6 | 28 | 49 |
| F160.080.R | 8 | 28 | 49 |
| F160.100.R | 10 | 28 | 49 |

▲ Solid carbide

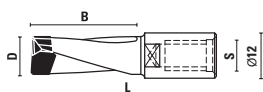

To be used on Festool® joining machines "Domino XL DF700"
Suitable for creating dowel cross-cut for making "Domino®" joints for kitchen cabinets, tables and door frames



| S = M8x1 | D | B | L |
|----------------|----|----|----|
| F161.080.R NEW | 8 | 50 | 90 |
| F161.100.R NEW | 10 | 70 | 90 |
| F161.120.R NEW | 12 | 70 | 90 |
| F161.140.R NEW | 14 | 70 | 90 |

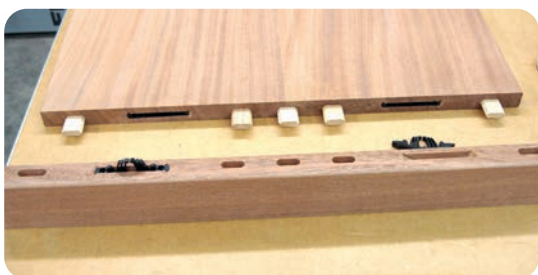

HW FLUSH TRIMMING BITS WITH BALL BEARING GUIDE Z=2

ART. F108

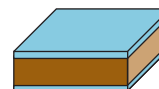
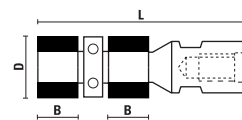

| S = M12x1 | D | B | L |
|------------|----|----|----|
| F108.190.R | 19 | 20 | 75 |



Z050.020.N

HW RADIUS BITS Z=2

ART. F110

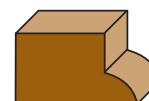
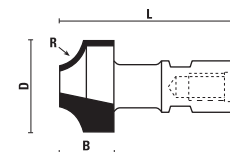

| S = M12x1 | D | R | B | L |
|------------------------|----|----|----|----|
| F110.320.R selling out | 32 | 10 | 15 | 60 |
| F110.370.R selling out | 37 | 12 | 18 | 60 |

HW RADIUS BITS WITH BALL BEARING GUIDE Z=2

ART. F111

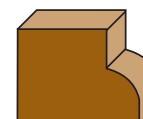
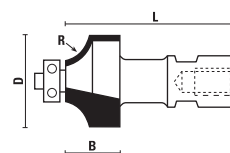

| S = M12x1 | D | R | B | L |
|------------|----|----|----|----|
| F111.290.R | 29 | 8 | 13 | 60 |
| F111.330.R | 33 | 10 | 15 | 60 |
| F111.370.R | 37 | 12 | 17 | 60 |
| F111.430.R | 43 | 15 | 20 | 60 |
| F111.530.R | 53 | 20 | 25 | 60 |

HW RADIUS BITS Z=2

ART. F112

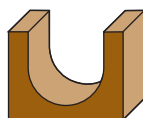
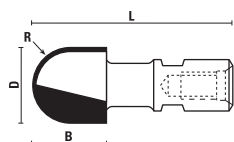

| S = M12x1 | D | R | B | L |
|------------|----|----|----|----|
| F112.160.R | 16 | 8 | 18 | 60 |
| F112.200.R | 20 | 10 | 18 | 60 |
| F112.240.R | 24 | 12 | 18 | 60 |
| F112.300.R | 30 | 15 | 18 | 60 |

HW RADIUS BITS Z=2

ART. F114

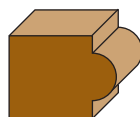
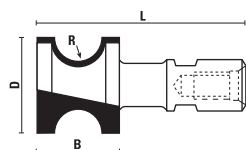

| S = M12x1 | D | R | B | L |
|------------|----|----|----|----|
| F114.450.R | 45 | 15 | 50 | 80 |

visit our website
www.sistemiklein.com



Router bits for handportable machines economy line



4



HW STRAIGHT BITS Z=2
Page 4.03



HW DOVETAIL BITS Z=2
Page 4.03

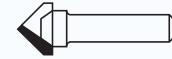

HW "V"-GROOVING BITS Z=2
Page 4.03

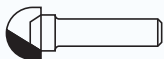

HW CORE BOX BITS Z=2
Page 4.03

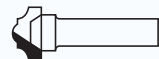

HW CLASSICAL BITS Z=2
Page 4.03



HW FLUSH TRIMMING BITS WITH BALL BEARING Z=2
Page 4.03

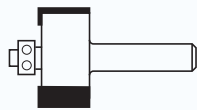

HW RABBETTING BITS WITH BALL BEARING Z=2
Page 4.03

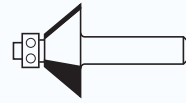

HW BEVEL TRIMMING BITS WITH BALL BEARING Z=2
Page 4.04

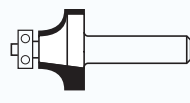

HW ROUNDING OVER BITS WITH BALL BEARING Z=2
Page 4.04

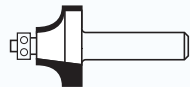

HW BEADING BITS WITH BALL BEARING Z=2
Page 4.04

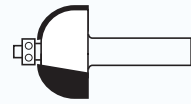

HW COVE BITS WITH BALL BEARING Z=2
Page 4.04

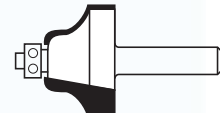

HW OGEE BITS WITH BALL BEARING Z=2
Page 4.04

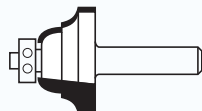

HW CLASSICAL BITS WITH BALL BEARING Z=2
Page 4.04



VHW FLUSH TRIMMER - Z=1
Page 4.05



VHW BEVEL TRIMMER - Z=1
Page 4.05



VHW COMBINATION FLUSH & BEVEL TRIMMER - Z=1
Page 4.05



VHW RIP & SLOTTING BITS - Z=1
Page 4.05



6 PIECE CLASSICAL HOBBY ROUTER BITS "STARTER SET"
Page 4.06



12 PIECE CLASSICAL HOBBY ROUTER BITS "ADVANCED SET"
Page 4.06



DISPLAY UNITS
Page 4.07



Klein[®]

HW STRAIGHT BITS Z=2

ART. HA101 - HB101 - HC101

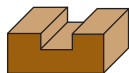
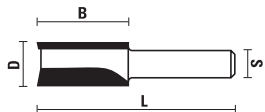

| S Ø 6 | S Ø 6,4 (1/4") | S Ø 8 | D | B | L |
|-------------|----------------|-------------|------|----|----|
| HA101.050.R | HB101.050.R | HC101.050.R | 5 | 12 | 48 |
| HA101.060.R | HB101.060.R | HC101.060.R | 6 | 20 | 48 |
| HA101.080.R | HB101.080.R | HC101.080.R | 8 | 20 | 48 |
| HA101.100.R | HB101.100.R | HC101.100.R | 10 | 20 | 48 |
| HA101.120.R | HB101.120.R | HC101.120.R | 12 | 20 | 48 |
| HA101.127.R | HB101.127.R | HC101.127.R | 12,7 | 20 | 48 |
| HA101.140.R | HB101.140.R | HC101.140.R | 14 | 20 | 48 |
| HA101.160.R | HB101.160.R | HC101.160.R | 16 | 20 | 48 |
| HA101.180.R | HB101.180.R | HC101.180.R | 18 | 20 | 48 |
| HA101.190.R | HB101.190.R | HC101.190.R | 19 | 20 | 48 |
| HA101.200.R | HB101.200.R | HC101.200.R | 20 | 20 | 48 |

HW DOVETAIL BITS Z=2

ART. HA108 - HB108 - HC108

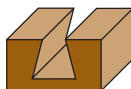
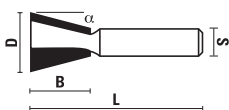

| S Ø 6 | S Ø 6,4 (1/4") | S Ø 8 | D | B | α | L |
|-------------|----------------|-------------|------|----|-----|----|
| HA108.127.R | HB108.127.R | HC108.127.R | 12,7 | 13 | 14° | 45 |

HW "V"-GROOVING BITS Z=2

ART. HA109 - HB109 - HC109
HA110 - HB110 - HC110

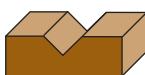
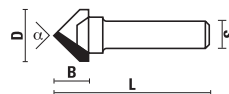

| S Ø 6 | S Ø 6,4 (1/4") | S Ø 8 | D | B | α | L |
|-------------|----------------|-------------|------|----|-----|----|
| HA109.127.R | HB109.127.R | HC109.127.R | 12,7 | 8 | 90° | 40 |
| HA110.095.R | HB110.095.R | HC110.095.R | 9,5 | 10 | 60° | 42 |

HW CORE BOX BITS Z=2

ART. HA111 - HB111 - HC111

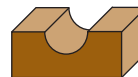
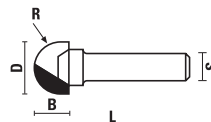

| S Ø 6 | S Ø 6,4 (1/4") | S Ø 8 | D | B | R | L |
|-------------|----------------|-------------|------|---|-----|----|
| HA111.064.R | HB111.064.R | HC111.064.R | 6,4 | 5 | 3,2 | 47 |
| HA111.127.R | HB111.127.R | HC111.127.R | 12,7 | 8 | 6,4 | 47 |

HW CLASSICAL BITS Z=2

ART. HA115 - HB115 - HC115

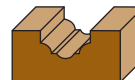
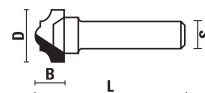

| S Ø 6 | S Ø 6,4 (1/4") | S Ø 8 | D | B | L |
|-------------|----------------|-------------|------|---|----|
| HA115.127.R | HB115.127.R | HC115.127.R | 12,7 | 8 | 40 |

HW FLUSH TRIMMING BITS WITH BALL BEARING Z=2

ART. HA119 - HB119 - HC119

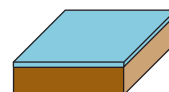
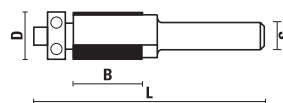

Ideal for working laminated panels

| S Ø 6 | S Ø 6,4 (1/4") | S Ø 8 | D | B | L |
|-------------|----------------|-------------|------|----|----|
| HA119.127.R | HB119.127.R | HC119.127.R | 12,7 | 13 | 54 |

HW RABBETING BITS WITH BALL BEARING Z=2

ART. HA121 - HB121 - HC121

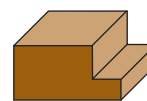
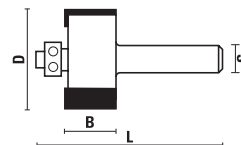

| S Ø 6 | S Ø 6,4 (1/4") | S Ø 8 | D | B | E | L |
|-------------|----------------|-------------|------|----|-----|----|
| HA121.286.R | HB121.286.R | HC121.286.R | 28,6 | 13 | 9,5 | 47 |

HW BEVEL TRIMMING BITS WITH BALL BEARING Z=2

ART. HA122 - HB122 - HC122

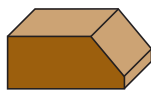
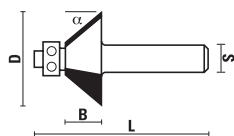

| S Ø 6 | S Ø 6,4 (1/4") | S Ø 8 | D | B | α | L |
|-------------|----------------|-------------|----|------|-----|----|
| HA122.160.R | HB122.160.R | HC122.160.R | 16 | 6,5 | 25° | 47 |
| HA122.320.R | HB122.320.R | HC122.320.R | 32 | 12,5 | 45° | 47 |

HW ROUNDING OVER BITS WITH BALL BEARING Z=2

ART. HA123 - HB123 - HC123

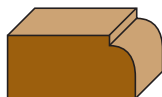
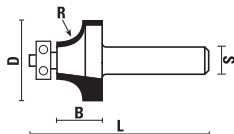

| S Ø 6 | S Ø 6,4 (1/4") | S Ø 8 | D | B | R | L |
|-------------|----------------|-------------|------|----|-----|----|
| HA123.158.R | HB123.158.R | HC123.158.R | 15,8 | 10 | 3,2 | 44 |
| HA123.220.R | HB123.220.R | HC123.220.R | 22 | 13 | 6,3 | 46 |
| HA123.250.R | HB123.250.R | HC123.250.R | 25 | 15 | 8 | 49 |
| HA123.286.R | HB123.286.R | HC123.286.R | 28,6 | 17 | 9,5 | 50 |

HW BEADING BITS WITH BALL BEARING Z=2

ART. HA124 - HB124 - HC124

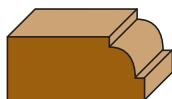
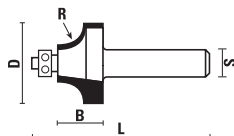

| S Ø 6 | S Ø 6,4 (1/4") | S Ø 8 | D | B | R | L |
|-------------|----------------|-------------|------|----|-----|----|
| HA124.158.R | HB124.158.R | HC124.158.R | 15,8 | 10 | 3,2 | 44 |
| HA124.220.R | HB124.220.R | HC124.220.R | 22 | 13 | 6,3 | 46 |
| HA124.250.R | HB124.250.R | HC124.250.R | 25 | 15 | 8 | 49 |
| HA124.286.R | HB124.286.R | HC124.286.R | 28,6 | 17 | 9,5 | 50 |

HW COVE BITS WITH BALL BEARING Z=2

ART. HA125 - HB125 - HC125

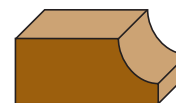
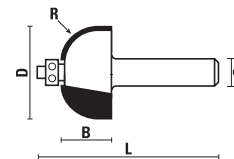

| S Ø 6 | S Ø 6,4 (1/4") | S Ø 8 | D | B | R | L |
|-------------|----------------|-------------|------|----|-----|----|
| HA125.220.R | HB125.220.R | HC125.220.R | 22 | 13 | 6,3 | 47 |
| HA125.286.R | HB125.286.R | HC125.286.R | 28,6 | 14 | 9,5 | 48 |

HW OGEE BITS WITH BALL BEARING Z=2

ART. HA127 - HB127 - HC127

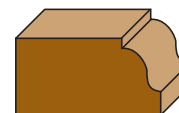
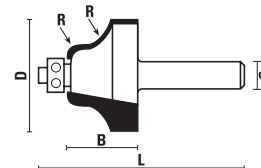

| S Ø 6 | S Ø 6,4 (1/4") | S Ø 8 | D | B | R | L |
|-------------|----------------|-------------|----|----|---|----|
| HA127.250.R | HB127.250.R | HC127.250.R | 25 | 16 | 4 | 50 |

HW CLASSICAL BITS WITH BALL BEARING Z=2

HA128 - HB128 - HC128

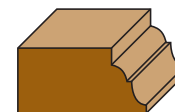
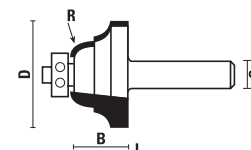

| S Ø 6 | S Ø 6,4 (1/4") | S Ø 8 | D | B | R | L |
|-------------|----------------|-------------|----|----|---|----|
| HA128.250.R | HB128.250.R | HC128.250.R | 25 | 16 | 4 | 50 |

VHW FLUSH TRIMMER - Z=1

ART. HB190

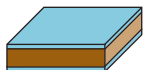

- Solid carbide
- Ideal for working laminated panels

| S Ø 6,4 (1/4") | D | B | L |
|-------------------------|------|-----|----|
| HB190.065.R - Top grind | 6,35 | 6,5 | 38 |
| HB190.096.R - Top grind | 6,35 | 9,6 | 38 |

VHW COMBINATION FLUSH & BEVEL TRIMMER - Z=1

ART. HB192

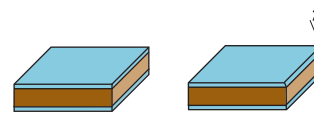

- Solid carbide
- Ideal for working laminated panels

| S Ø 6,4 (1/4") | D | B | α | L |
|----------------|-----|-----|----|----|
| HB192.064.R | 6,4 | 9,5 | 7° | 38 |

VHW BEVEL TRIMMER - Z=1

ART. HB191

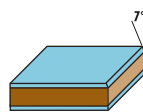
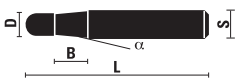

- Solid carbide
- Ideal for working laminated panels

| S Ø 6,4 (1/4") | D | B | α | L |
|-------------------------|---|-----|----|----|
| HB191.065.R - Top grind | 5 | 6,5 | 7° | 38 |

VHW RIP & SLOTTING BITS - Z=1

ART. HB193

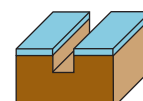

- Solid carbide
- Ideal for working laminated panels

| S Ø 6,4 (1/4") | D | B | L |
|----------------|-----|-----|----|
| HB193.064.R | 6,4 | 9,5 | 38 |

6 PIECE CLASSICAL HOBBY ROUTER BITS "STARTER SET"

ART. HX002



- Set including the 6 most popular hobby T.C.T. router bits in a robust and practical wooden box
- Ideal to have always on hand the right bit for straight cut, engraving and profiling

| HX002.006.R (S Ø 6) | HX002.008.R (S Ø 8) |
|-----------------------|-----------------------|
| 6-pcs router bit set: | 6-pcs router bit set: |
| HA101.060.R | HC101.060.R |
| HA101.120.R | HC101.120.R |
| HA109.127.R | HC109.127.R |
| HA123.286.R | HC123.286.R |
| HA124.220.R | HC124.220.R |
| HA127.250.R | HC127.250.R |

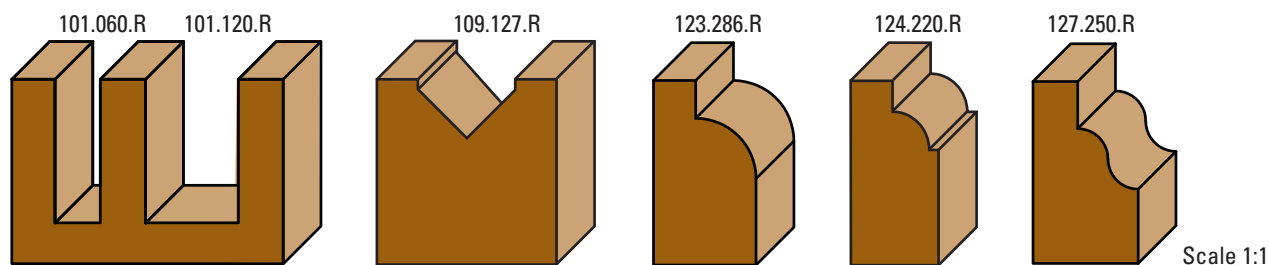

12 PIECE CLASSICAL HOBBY ROUTER BITS "ADVANCED SET"

ART. HX005



- Set including the 12 most popular hobby T.C.T. router bits in a robust and practical wooden box
- Ideal to have always on hand the right bit for straight cut, trimming, engraving, profiling and dovetail joints

| HX005.006.R (S Ø 6) | | HX005.008.R (S Ø 8) | |
|------------------------|-------------|------------------------|-------------|
| 12-pcs router bit set: | | 12-pcs router bit set: | |
| HA101.060.R | HA119.127.R | HC101.060.R | HC119.127.R |
| HA101.120.R | HA122.320.R | HC101.120.R | HC122.320.R |
| HA101.160.R | HA123.220.R | HC101.160.R | HC123.220.R |
| HA108.127.R | HA123.286.R | HC108.127.R | HC123.286.R |
| HA109.127.R | HA125.220.R | HC109.127.R | HC125.220.R |
| HA111.127.R | HA127.250.R | HC111.127.R | HC127.250.R |

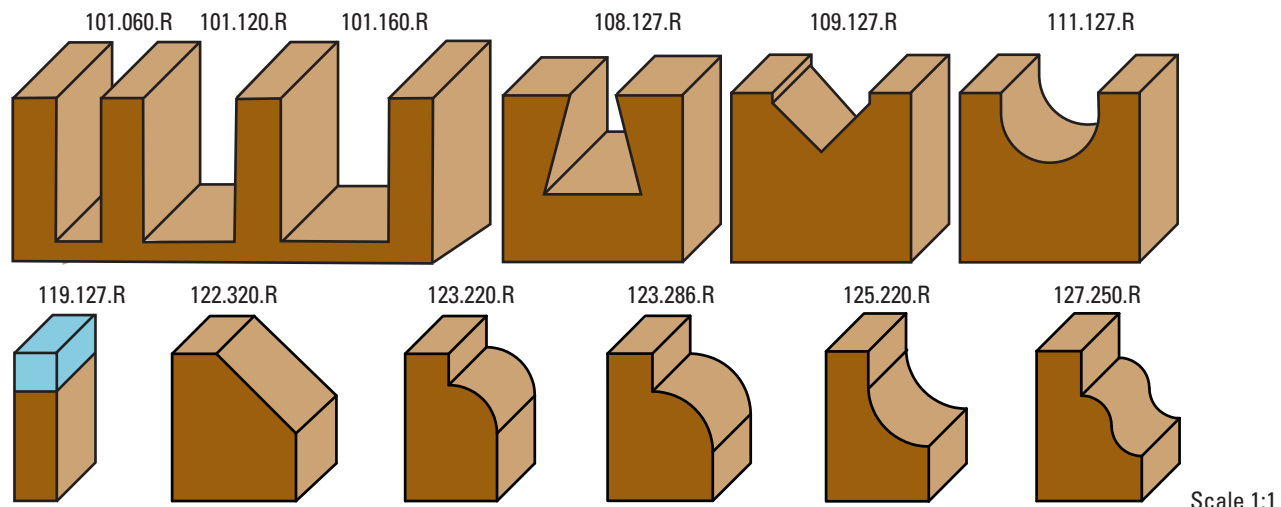

DISPLAY UNITS

BASE
1 modular panel

Little display unit, suitable for those who mean to start with a sufficient choice for a small number of customers.
Dimensions (cm): 110 (L) x 90 (H) x 30 (P)

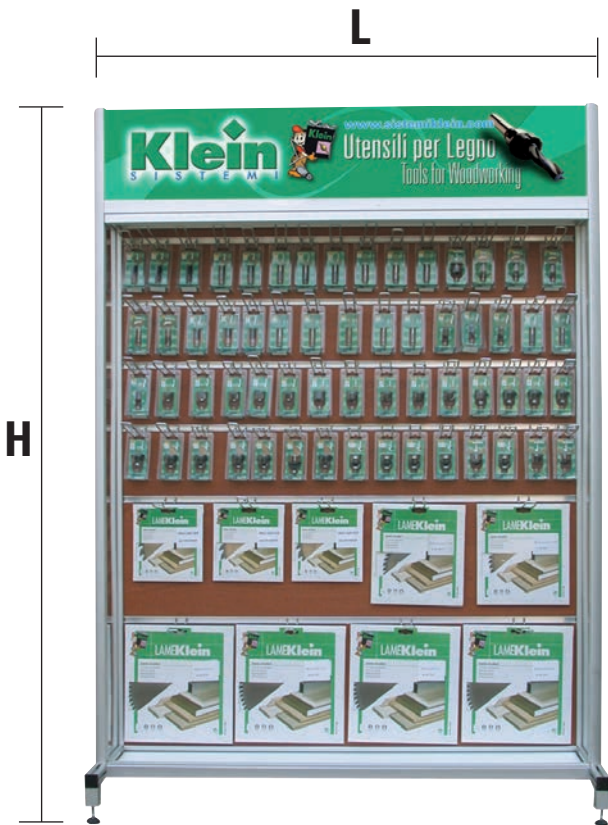

STANDARD
2 modular panels

Consisting of two "Basic model" displays, can be composed according to the customer's requirements. It is suitable for anyone who wants to have a good choice of items in view to improve his offer.
Dimensions (cm): 110 (L) x 145 (H) x 36 (P)

PROFESSIONAL
3 modular panels

Large display, consisting of three "Basic model" units allows you to show a wide choice of items. By the combination of two or more displays, you can equip a wall and meet all professional woodworkers' requirements.
Dimensions (cm): 110 (L) x 200 (H) x 36 (P)

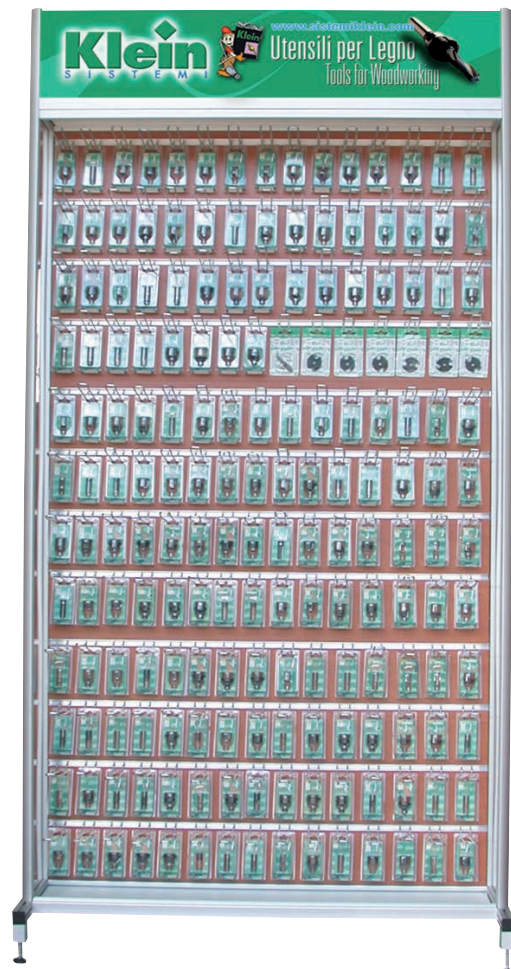

Dowel drills, boring bits for automatic boring machines



5

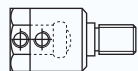

DRILL ADAPTORS
Page 5.04



QUICK CHANGE DRILL HOLDERS
Page 5.05, 5.06

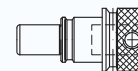

CHUCKS FOR MACHINES "BIESSE" WITH AUTOMATIC CHANGE
Page 5.06

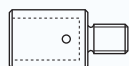

QUICK CHANGE CHUCKS
Page 5.06, 5.07



HW DOWEL DRILLS Z=2
Page 5.07



HW THROUGH HOLE DRILL BITS Z=2
Page 5.07



HW DOWEL DRILLS Z=2
Page 5.08



HW DOWEL DRILLS Z=2
Page 5.08



HW DOWEL DRILLS Z=2
Page 5.09



HW DOWEL DRILLS EXTRA FINE Z=2
Page 5.10



HW DOWEL DRILLS EXTRA TIME Z=2
Page 5.11



VHW DOWEL DRILLS EXTRA TIME Z=2
Page 5.11



VHW DOWEL DRILLS Z=2, KLEINDIA COATED
Pag. 5.12



VHW DOWEL DRILLS Z=2
Page 5.12



VHW DOWEL DRILLS Z=2
Pag. 5.12

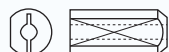

DRILL HOLDER-SLEEVES
Page 5.13



VHW TWIST DRILLS Z=2
Page 5.13

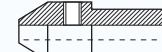

DRILL HOLDERS
Page 5.13



HW THROUGH HOLE DRILL BITS Z=2
Page 5.14



HW THROUGH HOLE DRILL BITS Z=2
Pag. 5.14



VHW THROUGH HOLE DRILL BITS Z=2
Page 5.15

Klein®





extra
bore

VHW THROUGH HOLE DRILL BITS Z=2,
KLEINDIA COATED
Pag. 5.15



HW COUNTERSINKS Z=2 - 90°
Page 5.16



VHW DOWEL DRILLS FOR BOTH RIGHT
HAND AND LEFT HAND ROTATION Z=1
Page 5.16



HW DOWEL DRILLS WITH
COUNTERSINK Z=2
Page 5.16

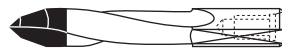

HW THROUGH HOLE DRILL BITS "E.T."
LINE Z=2
Page 5.17



VHW THROUGH HOLE DRILL BITS "E.T."
LINE Z=2
Page 5.17



extra
bore
VHW THROUGH HOLE DRILL BITS Z=2 "E.T."
LINE, KLEINDIA COATED
Pag. 5.17

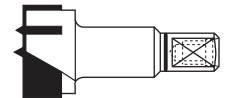

HW HINGE BORING BITS Z=2+2
Page 5.18

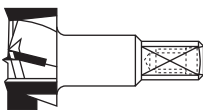

HW HINGE BORING BITS Z=3+3
Page 5.19

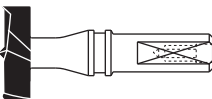

VHW HINGE BORING BITS Z=2+2
Page 5.19

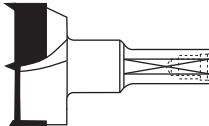

HW HINGE BORING BITS Z=2+2
Page 5.20

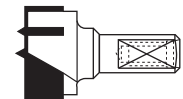

HW HINGE BORING BITS Z=2+2
Page 5.20



HW DOWEL DRILLS Z=2
Page 5.20

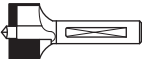

HW DRILLS FOR CABINEO® Z=2
Page 5.20

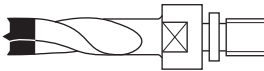

HW DOWEL DRILLS WITH THREADED
SHANK Z=2
Page 5.21



HW DOWEL DRILLS WITH
COUNTERSINK THREADED SHANK Z=2
Page 5.21



HW DOWEL DRILLS WITH THREADED
SHANK Z=2
Page 5.22



HW DOWEL DRILLS WITH COUNTERSINK
THREADED SHANK Z=2
Page 5.22

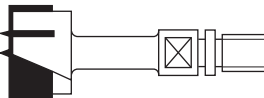

HW HINGE BORING BITS WITH THREADED
SHANK Z=2+2
Page 5.22

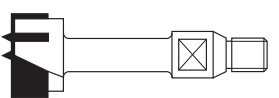

HW HINGE BORING BITS WITH
THREADED SHANK Z=2+2
Page 5.22

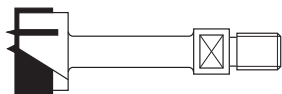

HW HINGE BORING BITS WITH
THREADED SHANK Z=2+2
Page 5.22



HW DOWEL DRILLS WITH THREADED
SHANK Z=2
Page 5.23



HW DOWEL DRILLS WITH THREADED
SHANK Z=2
Page 5.23



HW COUNTERBORE BITS
Page 5.23



MODULAR DRAWER UNIT
Page 5.24

DRILLING

The experience of **SISTEMI** is being always available to its customers in choosing the right tool for the desired processing. In this regard, a wide range of factors must be taken into consideration. Here is a summary list:

- 1) In addition to the traditional drilling bits with brazed carbide tips sometimes it is important to evaluate the use of **solid carbide drills** (Art. L116/L117/L118/L129/L134/L135) **that can ensure performance benefits**, longer life, higher number of resharpening times and higher resistance to breakage of tool body;
- 2) Choosing the drill bit according to the working material by properly setting RPM and feed speed as indicated in the following tables help to optimize the process;
- 3) To reduce the time of assembly and align the drills, **we recommend using our quick change drill chucks** (Art. L030 ÷ L060);
- 4) **Regular cleaning and maintenance** of the drills and adaptors **improve the performance and life of tools**, reducing the risk of breakage and increasing the quality of the worked pieces;
- 5) To improve the chips flow, the boring bits are coated with a **PTFE-based heat treatment** (Polytetrafluoroethylene) in black for Right Rotation and orange for Left Rotation.



How to choose the right Boring Bits

| Types of material Items | Softwood (Cider, Poplar, Pine, etc.) | Hardwood (Ash, Walnut, Beech, Oak, Teak, etc.) | Pressed Wood (Plywood, Blockboard) | Chipboard | Laminated Wood (Veneered, melamine coated panels, HPL, etc.) | MDF | Trespa® |
|---------------------------------------|---|---|---------------------------------------|-----------|---|-----|---------|
| L101/L102/L103/L104 - Pag. 5.07, 5.08 | XX | XX | XX | XX | X | XX | |
| L105/L106/L107/L108 - Pag. 5.08 | XX | XX | XX | XX | X | XX | |
| L109/L110 - Pag. 5.09 | XX | XX | XX | XX | X | XX | |
| L112/L113 - Pag. 5.10 | XX | XX | XXX | XXX | XXX | XXX | |
| L114/L115/L116/L117 - Pag. 5.11 | XX | XX | XXX | XXX | XXX | XXX | X |
| L118 - Pag. 5.12 | X | X | X | X | X | XX | XXX |
| L132/L133 - Pag. 5.17 | XXX | XXX | XXX | XXX | XXX | XXX | XX |
| L134/L135 - Pag. 5.17 | XXX | XXX | XXX | XXX | XXX | XXX | XX |
| L120 - Pag. 5.13 | XX | XX | XX | XX | XX | XX | X |
| L121/L122/L123/L124 - Pag. 5.07, 5.14 | XX | XX | XX | XX | X | XX | |
| L125/L126/L127 - Pag. 5.14 | XX | XX | XX | XX | X | XX | |
| L129 - Pag. 5.15 | XXX | XXX | XXX | XXX | XX | XXX | X |
| L140/L141/L142 - Pag. 5.18 | XX | XX | XXX | XXX | XX | XX | |
| L143/L144/L150/L151 - Pag. 5.18, 5.19 | XX | XX | XXX | XXX | X | XX | |
| L155 - Pag. 5.19 | XXX | XXX | XXX | XXX | XXX | XXX | XX |
| L160/L170 - Pag. 5.20 | XX | XX | XXX | XXX | XX | XX | |

X = Satisfactory - **XX** = Good - **XXX** = Excellent

Technical data and images are just an indication. **SISTEMI** srl reserves the right to modify the above information at any time and without notice.

DRILL ADAPTORS

ART. L001 - M10/11x4

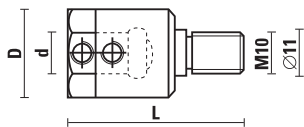

For: MORBIDELLI, BIESSE, WEEKE

| RH rotation | LH rotation | d | D | L |
|-------------|-------------|----|------|----|
| L001.080.R | L001.080.L | 8 | 15,5 | 41 |
| L001.100.R | L001.100.L | 10 | 19,5 | 41 |



Z051.301.R

DRILL ADAPTORS

ART. L004 - M8/9x3

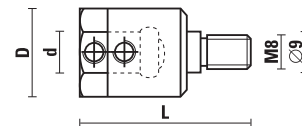

For: MORBIDELLI, NOTTMEYER

| RH rotation | LH rotation | d | D | L |
|-------------|-------------|----|------|----|
| L004.080.R | L004.080.L | 8 | 15,5 | 41 |
| L004.100.R | L004.100.L | 10 | 19,5 | 41 |
| L004.101.R | L004.101.L | 10 | 15 | 41 |



Z051.301.R

DRILL ADAPTORS

ART. L002 - M10/Taper 30°

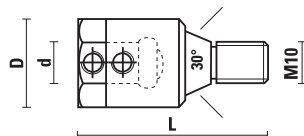

For: VITAP, BUSELLATO, SCHLEICHER

| RH rotation | LH rotation | d | D | L |
|-------------|-------------|----|------|----|
| L002.080.R | L002.080.L | 8 | 15,5 | 46 |
| L002.100.R | L002.100.L | 10 | 19,5 | 46 |



Z051.301.R

DRILL ADAPTORS

ART. L005 - M8

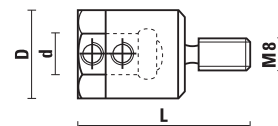

For: NOTTMEYER

| RH rotation | LH rotation | d | D | L |
|-------------|-------------|----|------|----|
| L005.080.R | L005.080.L | 8 | 15,5 | 40 |
| L005.100.R | L005.100.L | 10 | 19,5 | 40 |



Z051.301.R

DRILL ADAPTORS

ART. L003 - M10

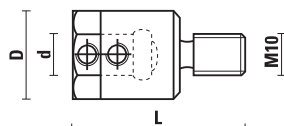

For: AYEN, HOLZMA, MAYER

| RH rotation | LH rotation | d | D | L |
|-------------|-------------|----|------|----|
| L003.080.R | L003.080.L | 8 | 15,5 | 40 |
| L003.100.R | L003.100.L | 10 | 19,5 | 40 |



Z051.301.R

DRILL ADAPTORS

ART. L006 - M8 - 20°48'

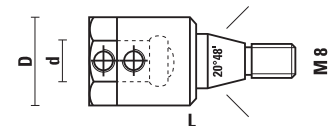

For: BILEK

| RH rotation | LH rotation | d | D | L |
|-------------|-------------|----|------|----|
| L006.080.R | L006.080.L | 8 | 15,5 | 51 |
| L006.100.R | L006.100.L | 10 | 19,5 | 51 |



Z051.301.R

QUICK CHANGE DRILL HOLDERS

ART. L030

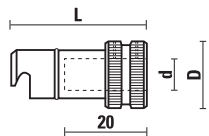

For: **BIESSE**

| RH rotation | LH rotation | d | D | L |
|-------------|---------------------|-----|----|----|
| L030.100.R | L030.100.L | 10 | 20 | 37 |
| L030.101.R | L030.101.L lowered | 10 | 20 | 30 |
| L030.102.R | L030.102.L threaded | M10 | 20 | 37 |



Z051.314.R

QUICK CHANGE DRILL HOLDERS

ART. L031

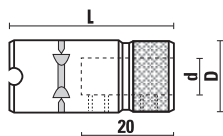

For: **MORBIDELLI**

| RH rotation | LH rotation | d | D | L |
|--------------------|---------------------|-----|----|----|
| L031.100.R | | 10 | 20 | 43 |
| L031.101.R lowered | | 10 | 16 | 43 |
| L031.102.R | L031.102.L threaded | M10 | 20 | 43 |



Z051.314.R
(L031.100.R)



Z051.313.R
(L031.101.R)

QUICK CHANGE DRILL HOLDERS

ART. L031

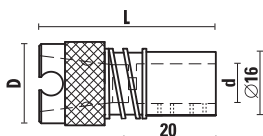

For: **MORBIDELLI** machines, with pull out spring

| Item | d | D | L |
|------------|----|----|----|
| L031.500.R | 10 | 20 | 44 |



Z051.301.R

ADAPTORS

ART. L031

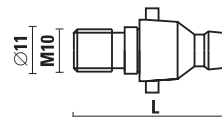

- Adaptor for quick change chucks
- For: **MORBIDELLI, SCM** with shank M10/11
- Use with: **Art. L031.100.R** and/or **Art. L031.500.R**

| RH rotation | LH rotation | L |
|-------------|-------------|----|
| L031.600.R | L031.600.L | 37 |

QUICK CHANGE DRILL HOLDERS

ART. L032

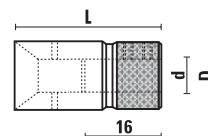

For: **MASTERWOOD, MAGGI, GRIGGIO**

| Item | d | D | L |
|------------|----|----|----|
| L032.100.R | 10 | 20 | 40 |

For: **MINIMAX**

| Item | d | D | L |
|------------|----|----|----|
| L032.200.R | 10 | 20 | 40 |



Z051.301.R

QUICK CHANGE DRILL HOLDERS

ART. L033

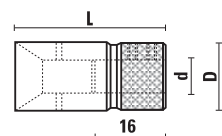

For: **VITAP**

| Item | d | D | L |
|------------|----|----|----|
| L033.100.R | 10 | 18 | 42 |



Z051.313.R

QUICK CHANGE DRILL HOLDERS

ART. L034

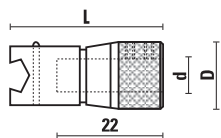

For: **BUSELLATO**

| Item | d | D | L |
|------------|----|----|------|
| L034.100.R | 10 | 19 | 34,5 |



Z051.313.R

QUICK CHANGE DRILL HOLDERS

ART. L035

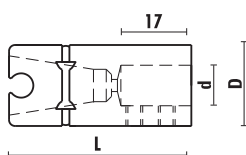

For: **DETEL**

| Item | d | D | L |
|------------|----|----|----|
| L035.100.R | 10 | 20 | 45 |



Z051.314.R

QUICK CHANGE DRILL HOLDER

ART. L036

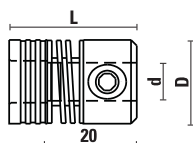

For: **GRASS**

| Item | d | D | L |
|------------|----|----|------|
| L036.100.R | 10 | 22 | 38,5 |



Z051.304.R

CHUCKS FOR MACHINES "BIESSE" WITH AUTOMATIC CHANGE

ART. L060

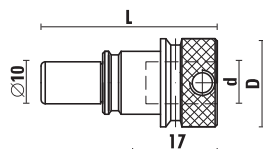

| Item | d | D | L |
|------------|----|----|----|
| L060.100.N | 10 | 21 | 42 |



Z051.314.R

QUICK CHANGE DRILL HOLDERS

ART. L040

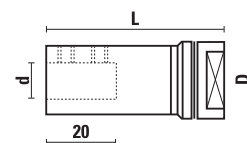

For: **WEEKE**

| Item | d | D | L |
|------------|----|----|----|
| L040.100.R | 10 | 20 | 46 |
| L040.101.R | 10 | 20 | 56 |
| L040.102.R | 10 | 20 | 66 |



Z051.314.R

QUICK CHANGE CHUCKS

ART. L050

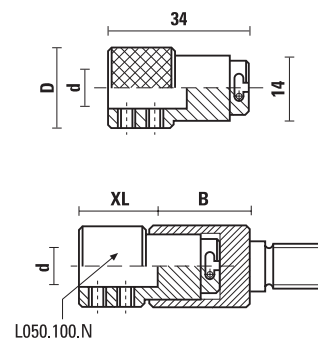

For art.: **L051 - L052 - L053 - L054**

| Item | d | D | XL |
|------------|----|----|------|
| L050.100.N | 10 | 18 | 17,5 |



Z051.301.R

QUICK CHANGE CHUCKS

ART. L051

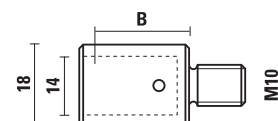

For: **AYEN, HOLZMA**

| RH rotation | LH rotation | B |
|-------------|-------------|------|
| L051.100.R | L051.100.L | 22,5 |

QUICK CHANGE CHUCKS

ART. L052

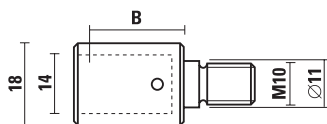

For: MORBIDELLI, BIESSE, WEEKE, BUSELLATO, TORWEGGE

| RH rotation | LH rotation | B |
|-------------|-------------|------|
| L052.100.R | L052.100.L | 22,5 |

QUICK CHANGE CHUCKS

ART. L053

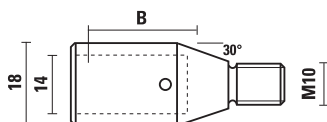

For: VITAP, ALBERTI

| RH rotation | LH rotation | B |
|-------------|-------------|------|
| L053.100.R | L053.100.L | 25,5 |

QUICK CHANGE CHUCKS

ART. L054

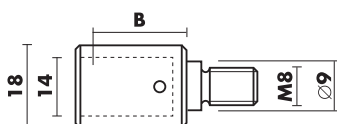

For: NOTTMEYER

| RH rotation | LH rotation | B |
|-------------|-------------|------|
| L054.100.R | L054.100.L | 25,5 |

HW DOWEL DRILLS Z=2

ART. L101 - L102

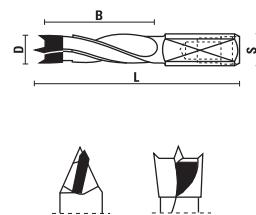

- 4-flutes
- Spurs ground with negative cutting angle for a good finish
- PTFE-Based coating for a better chip flow
- For natural wood, pressed wood, veneered, chipboard, laminated and MDF
- Can be used on **Mafell** drilling machines

| RH rotation | LH rotation | D | B | L | S |
|-------------|-------------|----|----|------|------|
| L101.050.R | L101.050.L | 5 | 30 | 55,5 | 8X20 |
| L101.060.R | L101.060.L | 6 | 30 | 55,5 | 8X20 |
| L101.070.R | L101.070.L | 7 | 30 | 55,5 | 8X20 |
| L101.080.R | L101.080.L | 8 | 30 | 55,5 | 8X20 |
| L101.090.R | L101.090.L | 9 | 30 | 55,5 | 8X20 |
| L101.100.R | L101.100.L | 10 | 30 | 55,5 | 8X20 |
| L101.120.R | L101.120.L | 12 | 30 | 55,5 | 8X20 |
| L102.050.R | L102.050.L | 5 | 40 | 67 | 8X20 |
| L102.060.R | L102.060.L | 6 | 40 | 67 | 8X20 |
| L102.070.R | L102.070.L | 7 | 40 | 67 | 8X20 |
| L102.080.R | L102.080.L | 8 | 40 | 67 | 8X20 |
| L102.090.R | L102.090.L | 9 | 40 | 67 | 8X20 |
| L102.100.R | L102.100.L | 10 | 40 | 67 | 8X20 |
| L102.120.R | L102.120.L | 12 | 40 | 67 | 8X20 |



Z051.302.R

HW THROUGH HOLES DRILL BITS Z=2

ART. L121 - L122

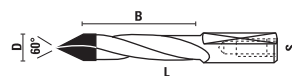

- 2-flutes
- PTFE-Based coating for a better chip flow
- For natural wood, pressed wood, veneered, chipboard, laminated and MDF

| RH rotation | LH rotation | D | B | L | S |
|-------------|-------------|---|----|------|------|
| L121.050.R | L121.050.L | 5 | 25 | 55,5 | 8X20 |
| L121.080.R | L121.080.L | 8 | 25 | 55,5 | 8X20 |
| L122.050.R | L122.050.L | 5 | 35 | 67 | 8X20 |
| L122.080.R | L122.080.L | 8 | 35 | 67 | 8X20 |



Z051.302.R

HW DOWEL DRILLS Z=2

ART. L103 - L104

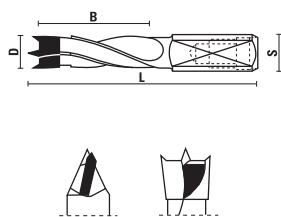

- 4-flutes (∅4 with 2 flutes)
- Spurs ground with negative cutting angle for a good finish
- PTFE-Based coating for a better chip flow
- For natural wood, pressed wood, veneered, chipboard, laminated and MDF

| Rotaz. DX | Rotaz. SX | D | B | L | S |
|------------|------------|------|----|------|-------|
| L103.040.R | L103.040.L | 4 | 30 | 57,5 | 10X20 |
| L103.050.R | L103.050.L | 5 | 30 | 57,5 | 10X20 |
| L103.055.R | L103.055.L | 5,5 | 30 | 57,5 | 10X20 |
| L103.060.R | L103.060.L | 6 | 30 | 57,5 | 10X20 |
| L103.064.R | L103.064.L | 6,4 | 30 | 57,5 | 10X20 |
| L103.070.R | L103.070.L | 7 | 30 | 57,5 | 10X20 |
| L103.075.R | L103.075.L | 7,5 | 30 | 57,5 | 10X20 |
| L103.080.R | L103.080.L | 8 | 30 | 57,5 | 10X20 |
| L103.085.R | L103.085.L | 8,5 | 30 | 57,5 | 10X20 |
| L103.090.R | L103.090.L | 9 | 30 | 57,5 | 10X20 |
| L103.095.R | L103.095.L | 9,5 | 30 | 57,5 | 10X20 |
| L103.100.R | L103.100.L | 10 | 30 | 57,5 | 10X20 |
| L103.105.R | L103.105.L | 10,5 | 30 | 57,5 | 10X20 |
| L103.110.R | L103.110.L | 11 | 30 | 57,5 | 10X20 |
| L103.120.R | L103.120.L | 12 | 30 | 57,5 | 10X20 |
| L103.127.R | L103.127.L | 12,7 | 30 | 57,5 | 10X20 |
| L103.130.R | L103.130.L | 13 | 30 | 57,5 | 10X20 |
| L103.140.R | L103.140.L | 14 | 30 | 57,5 | 10X20 |
| L103.150.R | L103.150.L | 15 | 30 | 57,5 | 10X20 |
| L103.160.R | L103.160.L | 16 | 30 | 57,5 | 10X20 |
| | | | | | |
| L104.040.R | L104.040.L | 4 | 43 | 70 | 10X20 |
| L104.045.R | L104.045.L | 4,5 | 43 | 70 | 10X20 |
| L104.050.R | L104.050.L | 5 | 43 | 70 | 10X20 |
| L104.055.R | L104.055.L | 5,5 | 43 | 70 | 10X20 |
| L104.060.R | L104.060.L | 6 | 43 | 70 | 10X20 |
| L104.064.R | L104.064.L | 6,4 | 43 | 70 | 10X20 |
| L104.070.R | L104.070.L | 7 | 43 | 70 | 10X20 |
| L104.075.R | L104.075.L | 7,5 | 43 | 70 | 10X20 |
| L104.080.R | L104.080.L | 8 | 43 | 70 | 10X20 |
| L104.082.R | L104.082.L | 8,2 | 43 | 70 | 10X20 |
| L104.085.R | L104.085.L | 8,5 | 43 | 70 | 10X20 |
| L104.090.R | L104.090.L | 9 | 43 | 70 | 10X20 |
| L104.095.R | L104.095.L | 9,5 | 43 | 70 | 10X20 |
| L104.100.R | L104.100.L | 10 | 43 | 70 | 10X20 |
| L104.105.R | L104.105.L | 10,5 | 43 | 70 | 10X20 |
| L104.110.R | L104.110.L | 11 | 43 | 70 | 10X20 |
| L104.120.R | L104.120.L | 12 | 43 | 70 | 10X20 |
| L104.127.R | L104.127.L | 12,7 | 43 | 70 | 10X20 |
| L104.130.R | L104.130.L | 13 | 43 | 70 | 10X20 |
| L104.140.R | L104.140.L | 14 | 43 | 70 | 10X20 |
| L104.150.R | L104.150.L | 15 | 43 | 70 | 10X20 |



HW DOWEL DRILLS Z=2

ART. L105 - L106 - L107 - L108

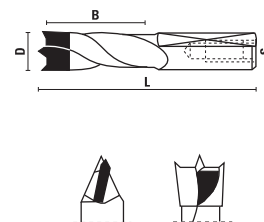

- 2-flutes
- Spurs ground with negative cutting angle for a good finish
- PTFE-Based coating for a better chip flow
- For natural wood, pressed wood, veneered, chipboard, laminated and MDF

| RH rotation | LH rotation | D | B | L | S |
|-------------|-------------|------|----|------|-------|
| L105.040.R | L105.040.L | 4 | 27 | 57,5 | 10x27 |
| L105.045.R | L105.045.L | 4,5 | 27 | 57,5 | 10x27 |
| L105.050.R | L105.050.L | 5 | 27 | 57,5 | 10x27 |
| L105.052.R | L105.052.L | 5,2 | 27 | 57,5 | 10x27 |
| L105.060.R | L105.060.L | 6 | 27 | 57,5 | 10x27 |
| L105.064.R | L105.064.L | 6,4 | 27 | 57,5 | 10x27 |
| L105.070.R | L105.070.L | 7 | 27 | 57,5 | 10x27 |
| L105.080.R | L105.080.L | 8 | 27 | 57,5 | 10x27 |
| L105.082.R | L105.082.L | 8,2 | 27 | 57,5 | 10x27 |
| L105.090.R | L105.090.L | 9 | 27 | 57,5 | 10x27 |
| L105.095.R | L105.095.L | 9,5 | 27 | 57,5 | 10x27 |
| L105.100.R | L105.100.L | 10 | 27 | 57,5 | 10x27 |
| L105.110.R | L105.110.L | 11 | 27 | 57,5 | 10x27 |
| L105.120.R | L105.120.L | 12 | 27 | 57,5 | 10x27 |
| L105.127.R | L105.127.L | 12,7 | 27 | 57,5 | 10x27 |
| L105.140.R | L105.140.L | 14 | 27 | 57,5 | 10x27 |
| L105.150.R | L105.150.L | 15 | 27 | 57,5 | 10x27 |
| | | | | | |
| L106.050.R | L106.050.L | 5 | 18 | 57,5 | 10x34 |
| L106.060.R | L106.060.L | 6 | 18 | 57,5 | 10x34 |
| L106.080.R | L106.080.L | 8 | 18 | 57,5 | 10x34 |
| L106.100.R | L106.100.L | 10 | 18 | 57,5 | 10x34 |
| | | | | | |
| L107.040.R | L107.040.L | 4 | 35 | 70 | 10x30 |
| L107.045.R | L107.045.L | 4,5 | 35 | 70 | 10x30 |
| L107.050.R | L107.050.L | 5 | 35 | 70 | 10x30 |
| L107.060.R | L107.060.L | 6 | 35 | 70 | 10x30 |
| L107.064.R | L107.064.L | 6,4 | 35 | 70 | 10x30 |
| L107.070.R | L107.070.L | 7 | 35 | 70 | 10x30 |
| L107.080.R | L107.080.L | 8 | 35 | 70 | 10x30 |
| L107.090.R | L107.090.L | 9 | 35 | 70 | 10x30 |
| L107.095.R | L107.095.L | 9,5 | 35 | 70 | 10x30 |
| L107.100.R | L107.100.L | 10 | 35 | 70 | 10x30 |
| L107.110.R | L107.110.L | 11 | 35 | 70 | 10x30 |
| L107.120.R | L107.120.L | 12 | 35 | 70 | 10x30 |
| L107.127.R | L107.127.L | 12,7 | 35 | 70 | 10x30 |
| L107.130.R | L107.130.L | 13 | 35 | 70 | 10x30 |
| L107.140.R | L107.140.L | 14 | 35 | 70 | 10x30 |
| L107.160.R | L107.160.L | 16 | 35 | 70 | 10x30 |
| | | | | | |
| L108.050.R | L108.050.L | 5 | 44 | 77 | 10X30 |
| L108.060.R | L108.060.L | 6 | 44 | 77 | 10X30 |
| L108.070.R | L108.070.L | 7 | 44 | 77 | 10X30 |
| L108.080.R | L108.080.L | 8 | 44 | 77 | 10X30 |
| L108.100.R | L108.100.L | 10 | 44 | 77 | 10X30 |
| L108.120.R | L108.120.L | 12 | 44 | 77 | 10X30 |



HW DOWEL DRILLS Z=2

ART. L109

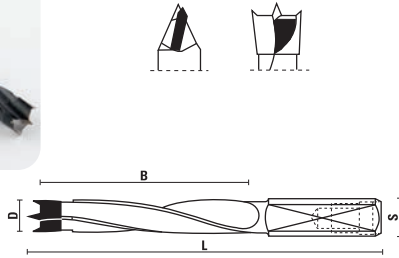

- 4-flutes
- Spurs ground with negative cutting angle for a good finish
- PTFE-Based coating for a better chip flow
- For natural wood, pressed wood, veneered, chipboard, laminated and MDF

| RH rotation | LH rotation | D | B | L | S |
|-------------|-------------|----|----|----|-------|
| L109.050.R | L109.050.L | 5 | 45 | 85 | 10X30 |
| L109.060.R | L109.060.L | 6 | 45 | 85 | 10X30 |
| L109.070.R | L109.070.L | 7 | 45 | 85 | 10X30 |
| L109.080.R | L109.080.L | 8 | 45 | 85 | 10X30 |
| L109.100.R | L109.100.L | 10 | 45 | 85 | 10X30 |
| L109.120.R | L109.120.L | 12 | 45 | 85 | 10X30 |



Z051.302.R

On request



Z051.505.R

HW DOWEL DRILLS Z=2

ART. L110

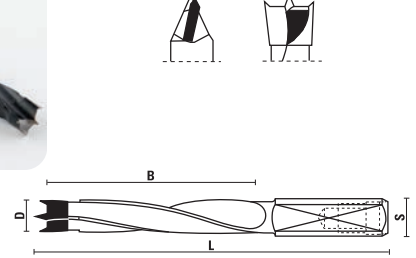

- 4-flutes
- Spurs ground with negative cutting angle for a good finish
- PTFE-Based coating for a better chip flow
- For natural wood, pressed wood, veneered, chipboard, laminated and MDF

| RH rotation | LH rotation | D | B | L | S |
|-------------|-------------|----|----|-----|-------|
| L110.050.R | L110.050.L | 5 | 65 | 105 | 10x30 |
| L110.060.R | L110.060.L | 6 | 65 | 105 | 10x30 |
| L110.070.R | L110.070.L | 7 | 65 | 105 | 10x30 |
| L110.080.R | L110.080.L | 8 | 65 | 105 | 10x30 |
| L110.100.R | L110.100.L | 10 | 65 | 105 | 10x30 |
| L110.120.R | L110.120.L | 12 | 65 | 105 | 10x30 |



Z051.302.R

On request



Z051.505.R

HW DOWEL DRILLS WITH 2 AND 4 FLUTES (from art. L101 to L110)

How to determine the feeding speed according to the machine (RPM):

- Referred to a standard common diameter

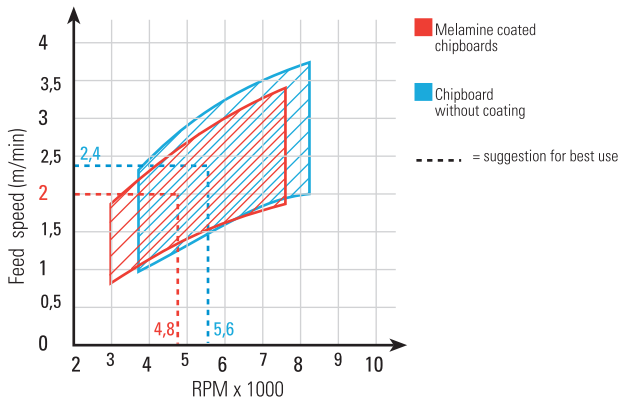

2 flutes version art. L105/L106/L107/L108

Recommended for panel machining due to less friction because of reduced tool body diameter. Countersink (art. L131) fixed on the tool shank

4 flutes version art. L101/L102/L103/L104/L109/L110

Countersink (art. L130) fixed on the tool flute

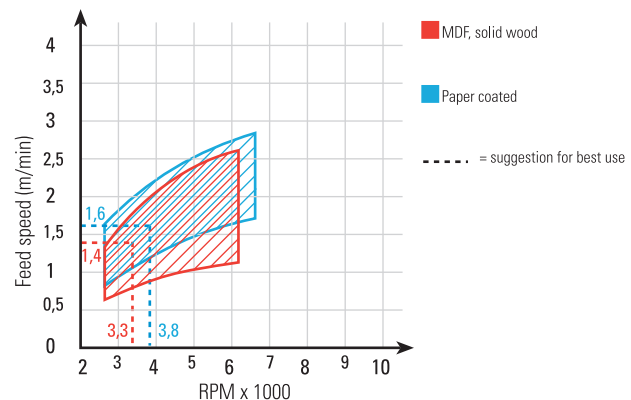

All drills (Art. L101÷L135) and hinge boring bits (Art. L140÷L142) are produced with tolerances according to instructions of Weeke Machines

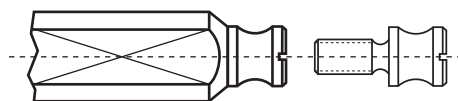

Screw Z051.505.R

HW DOWEL DRILLS EXTRA FINE Z=2

ART. L112 - L113

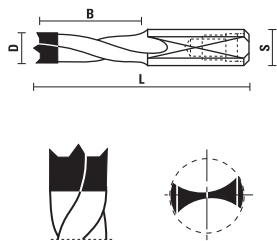

- **EXTRA FINE GRINDING TOOL**
- **2-flutes**
- **Rounded spurs and special HW for a better finish and longer lasting tool performance**
- PTFE-Based coating for a better chip flow
- For natural wood, pressed wood, veneered, chipboard, laminated and MDF

| RH rotation | LH rotation | D | B | L | S |
|-------------|-------------|-----|----|------|-------|
| L112.050.R | L112.050.L | 5 | 27 | 57,5 | 10X27 |
| L112.060.R | L112.060.L | 6 | 27 | 57,5 | 10X27 |
| L112.064.R | L112.064.L | 6,4 | 27 | 57,5 | 10X27 |
| L112.070.R | L112.070.L | 7 | 27 | 57,5 | 10X27 |
| L112.080.R | L112.080.L | 8 | 27 | 57,5 | 10X27 |
| L112.100.R | L112.100.L | 10 | 27 | 57,5 | 10X27 |
| L112.120.R | L112.120.L | 12 | 27 | 57,5 | 10x27 |
| | | | | | |
| L113.050.R | L113.050.L | 5 | 35 | 70 | 10x30 |
| L113.060.R | L113.060.L | 6 | 35 | 70 | 10x30 |
| L113.064.R | L113.064.L | 6,4 | 35 | 70 | 10x30 |
| L113.070.R | L113.070.L | 7 | 35 | 70 | 10x30 |
| L113.080.R | L113.080.L | 8 | 35 | 70 | 10x30 |
| L113.100.R | L113.100.L | 10 | 35 | 70 | 10x30 |
| L113.120.R | L113.120.L | 12 | 35 | 70 | 10x30 |



Z051.302.R

On request Z051.505.R

HW AND SOLID CARBIDE DOWEL DRILLS (art. L112 - L113)

How to determine the feeding speed according to the machine (RPM):

- Referred to a standard common diameter

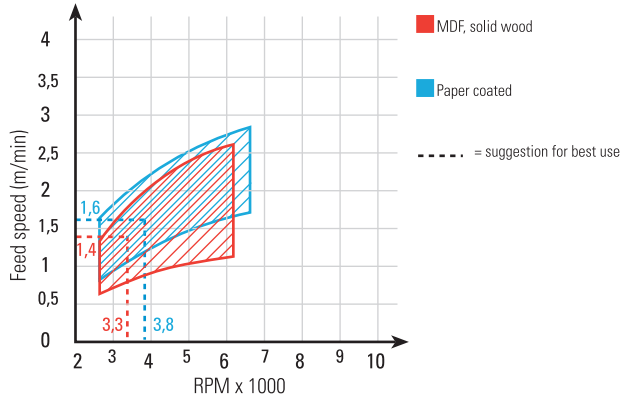
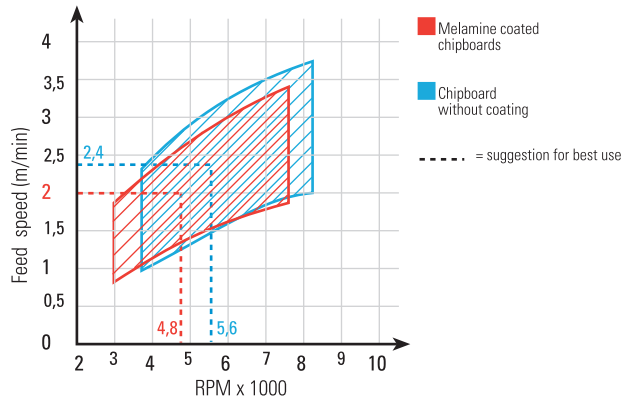

- High performance drills thanks to the special spur geometry;
- Suitable for working all materials with very good result;
- Suitable to work at higher feed speed and RPM.

SPURS GEOMETRY OF THE DOWEL DRILLS:

Negative spurs and center point

ART. L101 ÷ L110

STANDARD

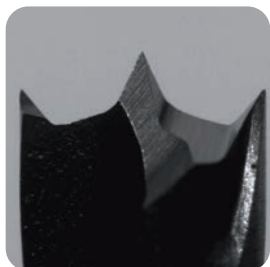

Front

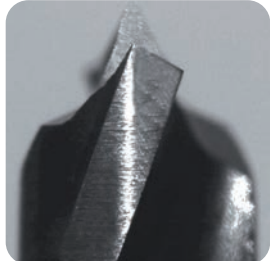

Side

- Good finish and tool life
- Lower price

Rounded spurs and center point

ART. L112 ÷ L113

EXTRA FINE

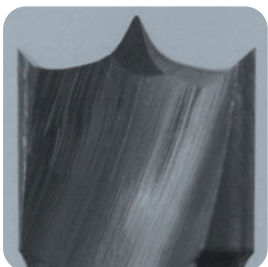

Front

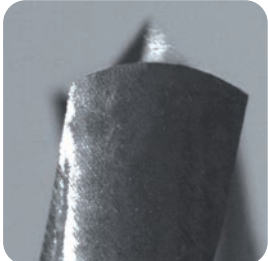

Side

- HW more resistant to wear
- Better finish
- Longer tool life

Rounded spurs and reinforced center point

ART. L114 ÷ L117

EXTRA TIME

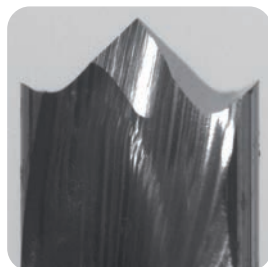

Front

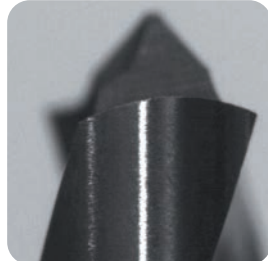

Side

- HW more resistant to wear
- Excellent finish
- Longer tool life
- Easier to sharpen
- Excellent performance in any working conditions
- Best price/quality ratio

Images taken with PRE SET LEADER Plus

HW DOWEL DRILLS EXTRA TIME Z=2

ART. L114 - L115

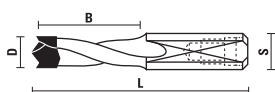

- **EXTRA TIME GRINDING TOOL**
- **2-flutes**
- **Rounded spurs and reinforced centre point**
- **Special HW**
- **Excellent finish and longer tool life**
- PTFE-Based coating for a better chip flow
- For natural wood, pressed wood, veneered, chipboard, laminated and MDF
- Suggested also for working trespa and melamine panels

| RH rotation | LH rotation | D | B | L | S |
|-------------|-------------|-----|----|------|-------|
| L114.050.R | L114.050.L | 5 | 27 | 57,5 | 10X27 |
| L114.060.R | L114.060.L | 6 | 27 | 57,5 | 10x27 |
| L114.064.R | L114.064.L | 6,4 | 27 | 57,5 | 10x27 |
| L114.070.R | L114.070.L | 7 | 27 | 57,5 | 10x27 |
| L114.080.R | L114.080.L | 8 | 27 | 57,5 | 10x27 |
| L114.100.R | L114.100.L | 10 | 27 | 57,5 | 10x27 |
| L114.120.R | L114.120.L | 12 | 27 | 57,5 | 10x27 |
| | | | | | |
| L115.050.R | L115.050.L | 5 | 35 | 70 | 10x30 |
| L115.060.R | L115.060.L | 6 | 35 | 70 | 10x30 |
| L115.064.R | L115.064.L | 6,4 | 35 | 70 | 10x30 |
| L115.070.R | L115.070.L | 7 | 35 | 70 | 10x30 |
| L115.080.R | L115.080.L | 8 | 35 | 70 | 10x30 |
| L115.100.R | L115.100.L | 10 | 35 | 70 | 10x30 |
| L115.120.R | L115.120.L | 12 | 35 | 70 | 10x30 |



Z051.302.R

On request



Z051.505.R

VHW DOWEL DRILLS EXTRA TIME Z=2

ART. L116 - L117

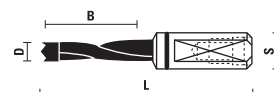

- **EXTRA TIME GRINDING TOOL**
- **Solid carbide spiral portion**
- **2-flutes**
- **Rounded spurs and reinforced centre point**
- **Special HW**
- **Excellent finish and longer tool life**
- For natural wood, pressed wood, veneered, chipboard, laminated and MDF
- Suggested also for working trespa and melamine panels

| RH rotation | LH rotation | D | B | L | S |
|-------------|-------------|-----|----|------|-------|
| L116.030.R | L116.030.L | 3 | 20 | 57,5 | 10X32 |
| L116.040.R | L116.040.L | 4 | 23 | 57,5 | 10X27 |
| L116.050.R | L116.050.L | 5 | 23 | 57,5 | 10X27 |
| L116.060.R | L116.060.L | 6 | 23 | 57,5 | 10X27 |
| L116.064.R | L116.064.L | 6,4 | 23 | 57,5 | 10X27 |
| L116.070.R | L116.070.L | 7 | 23 | 57,5 | 10X27 |
| L116.080.R | L116.080.L | 8 | 23 | 57,5 | 10X27 |
| | | | | | |
| L117.030.R | L117.030.L | 3 | 20 | 70 | 10x38 |
| L117.040.R | L117.040.L | 4 | 30 | 70 | 10x30 |
| L117.050.R | L117.050.L | 5 | 30 | 70 | 10x30 |
| L117.060.R | L117.060.L | 6 | 30 | 70 | 10x30 |
| L117.064.R | L117.064.L | 6,4 | 30 | 70 | 10x30 |
| L117.070.R | L117.070.L | 7 | 30 | 70 | 10x30 |
| L117.080.R | L117.080.L | 8 | 30 | 70 | 10x30 |



Z051.302.R



Z059.001.L



Z059.001.R

On request



Z051.505.R

HW AND SOLID CARBIDE DOWEL DRILLS (art. L114 - L115 - L116 - L117)

How to determine the feeding speed according to the machine (RPM):

- Referred to a standard common diameter

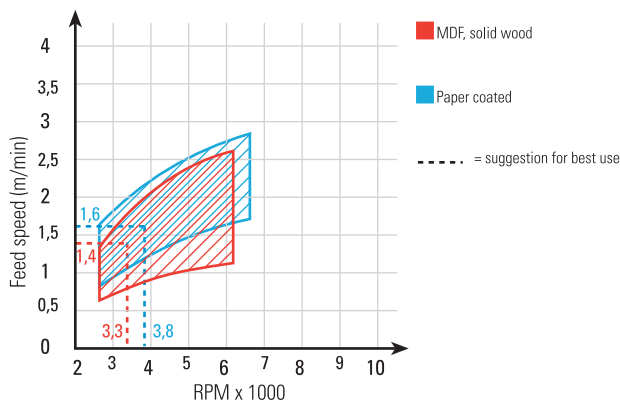
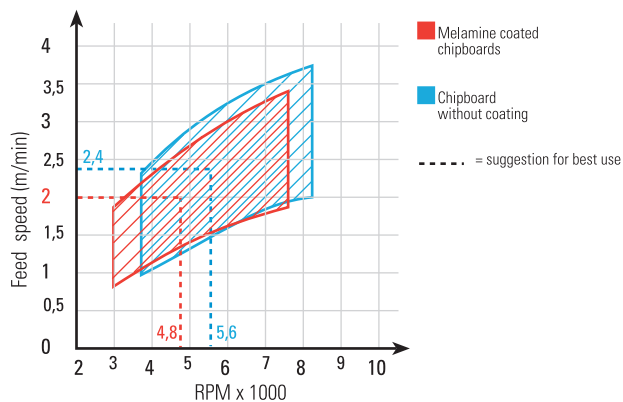

- Special spur geometry with reinforced centre point for excellent performance
- Recommended also for working problematic materials, like panels coated with paper
- Suitable to work at higher feed speed and RPM

VHW DOWEL DRILLS Z=2, KleinDIA COATED

ART. L116.KD - L117.KD

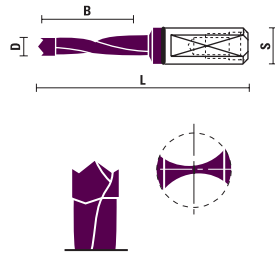

Xtra bore Tool life 4 times longer than uncoated tools

- **EXTRA TIME GRINDING TOOL** (rounded spurs and reinforced centering point)
- **Solid carbide spiral portion** (with 2-flutes)
- **Polished and coated cutting edge for improved chip evacuation and less friction**
- **Special HW** more resistant
- **Excellent finish and longer tool life for excellent performance**
- For natural wood, pressed wood, veneered, chipboard, laminated and MDF
- Suggested also for working **Trespa®** and melamine panels

| RH rotation | LH rotation | D | B | L | S |
|-------------------------|-------------------------|---|----|------|-------|
| L116.030.RKD NEW | L116.030.LKD NEW | 3 | 20 | 57,5 | 10X32 |
| L116.040.RKD NEW | L116.040.LKD NEW | 4 | 23 | 57,5 | 10X27 |
| L116.050.RKD NEW | L116.050.LKD NEW | 5 | 23 | 57,5 | 10X27 |
| L116.060.RKD NEW | L116.060.LKD NEW | 6 | 23 | 57,5 | 10X27 |
| L116.080.RKD NEW | L116.080.LKD NEW | 8 | 23 | 57,5 | 10X27 |

| | | | | | |
|-------------------------|-------------------------|---|----|----|-------|
| L117.030.RKD NEW | L117.030.LKD NEW | 3 | 20 | 70 | 10x38 |
| L117.040.RKD NEW | L117.040.LKD NEW | 4 | 30 | 70 | 10x30 |
| L117.050.RKD NEW | L117.050.LKD NEW | 5 | 30 | 70 | 10x30 |
| L117.060.RKD NEW | L117.060.LKD NEW | 6 | 30 | 70 | 10x30 |
| L117.080.RKD NEW | L117.080.LKD NEW | 8 | 30 | 70 | 10x30 |



THE NEW COATED BITS FOR LARGE SCALE INDUSTRY

Xtra bore

- **DLC DIAMOND ANTIFRICTION COATING**
- **LONGER TOOL LIFE**
- **EXCELLENT PERFORMANCE ON EVERY KIND OF MATERIAL**
- **GREATER PRODUCTIVITY**

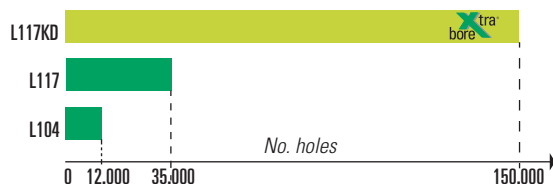

VHW DOWEL DRILLS Z=2

ART. L118



- **Solid carbide spiral portion**
- **2-flutes**
- For natural wood, pressed wood, veneered, chipboard, laminated and MDF
- Ideal for **Trespa**

| RH rotation | LH rotation | D | B | L | S |
|-------------|-------------|-----|----|----|-------|
| L118.040.R | L118.040.L | 4 | 32 | 70 | 10X30 |
| L118.050.R | L118.050.L | 5 | 32 | 70 | 10X30 |
| L118.060.R | L118.060.L | 6 | 32 | 70 | 10X30 |
| L118.064.R | L118.064.L | 6,4 | 32 | 70 | 10X30 |
| L118.070.R | L118.070.L | 7 | 32 | 70 | 10X30 |
| L118.080.R | L118.080.L | 8 | 32 | 70 | 10X30 |



VHW DOWEL DRILLS Z=2

ART. L119

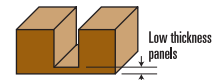
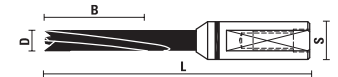

- **Solid carbide spiral portion**
- **2-flutes**
- **Flat center-point and two rounded spurs**
- For natural wood, pressed wood, veneered, chipboard, laminated and MDF
- **Best quality holes when working with low thickness panels** thanks to the flat center-point and two rounded spurs

| RH rotation | LH rotation | D | B | L | S |
|-----------------------|-----------------------|---|----|----|-------|
| L119.050.R NEW | L119.050.L NEW | 5 | 30 | 70 | 10x30 |
| L119.080.R NEW | L119.080.L NEW | 8 | 30 | 70 | 10x30 |



VHW TWIST DRILLS Z=2

ART. L120



- Solid carbide
- 2-flutes
- For natural wood, pressed wood, veneered, chipboard, laminated and MDF
- Ideal for Trespa
- To use with adaptor bushes Art. Z010/Z011

| RH rotation | LH rotation | D | B | L |
|-------------|-------------|-----|----|----|
| L120.020.R | L120.020.L | 2 | 18 | 49 |
| L120.025.R | L120.025.L | 2,5 | 22 | 55 |
| L120.030.R | L120.030.L | 3 | 22 | 55 |
| L120.032.R | L120.032.L | 3,2 | 22 | 55 |
| L120.035.R | L120.035.L | 3,5 | 25 | 55 |
| L120.040.R | L120.040.L | 4 | 25 | 55 |
| L120.045.R | L120.045.L | 4,5 | 28 | 58 |
| L120.050.R | L120.050.L | 5 | 28 | 58 |
| L120.060.R | L120.060.L | 6 | 28 | 58 |

VHW TWIST DRILLS (art. L120)

How to determine the feeding speed according to the machine (RPM):

- Referred to a standard common diameter

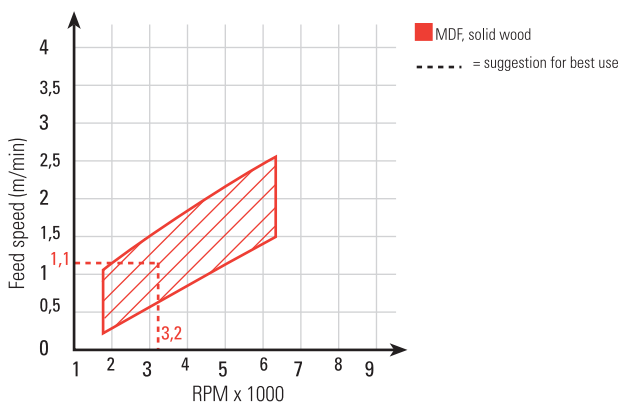
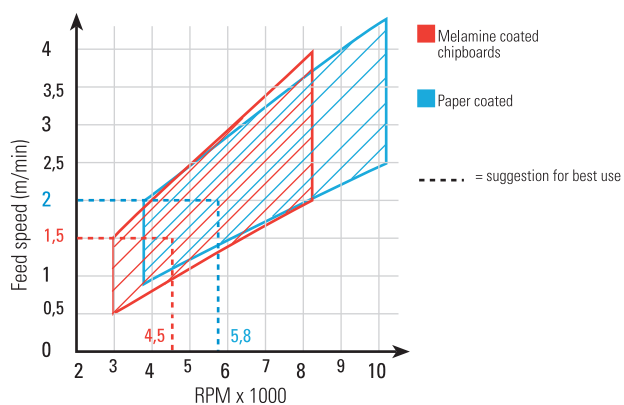

DRILL HOLDER-SLEEVES

ART. Z010

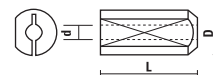

For Art. L120



| Item | d | D | L |
|------------|-----|----|----|
| Z010.020.N | 2 | 10 | 24 |
| Z010.025.N | 2,5 | 10 | 24 |
| Z010.030.N | 3 | 10 | 24 |
| Z010.032.N | 3,2 | 10 | 24 |
| Z010.035.N | 3,5 | 10 | 24 |
| Z010.040.N | 4 | 10 | 24 |
| Z010.045.N | 4,5 | 10 | 24 |
| Z010.050.N | 5 | 10 | 24 |
| Z010.060.N | 6 | 10 | 24 |

DRILL HOLDERS

ART. Z011

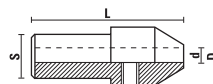

For Art. L120



| Item | d | D | L | S |
|------------|-----|----|----|-------|
| Z011.020.N | 2 | 15 | 35 | 10x19 |
| Z011.025.N | 2,5 | 15 | 35 | 10x19 |
| Z011.030.N | 3 | 15 | 35 | 10x19 |
| Z011.032.N | 3,2 | 15 | 35 | 10x19 |
| Z011.035.N | 3,5 | 15 | 35 | 10x19 |
| Z011.040.N | 4 | 15 | 35 | 10x19 |
| Z011.045.N | 4,5 | 15 | 35 | 10x19 |
| Z011.050.N | 5 | 15 | 35 | 10x19 |
| Z011.060.N | 6 | 15 | 35 | 10x19 |

HW THROUGH HOLE DRILL BITS Z=2

ART. L123 - L124 - L125

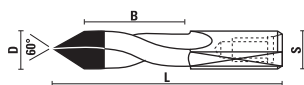

- 2-flutes
- PTFE-Based coating for a better chip flow
- For natural wood, pressed wood, veneered, chipboard, laminated and MDF

| RH rotation | LH rotation | D | B | L | S |
|-------------|-------------|-----|----|------|-------|
| L123.040.R | L123.040.L | 4 | 27 | 57,5 | 10X24 |
| L123.050.R | L123.050.L | 5 | 27 | 57,5 | 10X24 |
| L123.060.R | L123.060.L | 6 | 27 | 57,5 | 10X24 |
| L123.070.R | L123.070.L | 7 | 27 | 57,5 | 10X24 |
| L123.080.R | L123.080.L | 8 | 27 | 57,5 | 10X24 |
| L123.090.R | L123.090.L | 9 | 27 | 57,5 | 10X24 |
| L123.100.R | L123.100.L | 10 | 27 | 57,5 | 10X24 |
| | | | | | |
| L124.040.R | L124.040.L | 4 | 37 | 70 | 10X24 |
| L124.050.R | L124.050.L | 5 | 37 | 70 | 10X24 |
| L124.060.R | L124.060.L | 6 | 37 | 70 | 10X24 |
| L124.064.R | L124.064.L | 6,4 | 37 | 70 | 10X24 |
| L124.070.R | L124.070.L | 7 | 37 | 70 | 10X24 |
| L124.080.R | L124.080.L | 8 | 37 | 70 | 10X24 |
| L124.090.R | L124.090.L | 9 | 37 | 70 | 10X24 |
| L124.095.R | L124.095.L | 9,5 | 37 | 70 | 10X24 |
| L124.100.R | L124.100.L | 10 | 37 | 70 | 10X24 |
| L124.120.R | L124.120.L | 12 | 37 | 70 | 10X24 |
| | | | | | |
| L125.050.R | L125.050.L | 5 | 45 | 77 | 10X24 |
| L125.060.R | L125.060.L | 6 | 45 | 77 | 10X24 |
| L125.070.R | L125.070.L | 7 | 45 | 77 | 10X24 |
| L125.080.R | L125.080.L | 8 | 45 | 77 | 10X24 |
| L125.100.R | L125.100.L | 10 | 45 | 77 | 10X24 |



Z051.302.R



Z051.505.R

HW THROUGH HOLE DRILL BITS Z=2

ART. L126 - L127

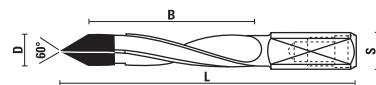

- 4-flutes
- PTFE-Based coating for a better chip flow
- For natural wood, pressed wood, veneered, chipboard, laminated and MDF

| RH rotation | LH rotation | D | B | L | S |
|-------------|-------------|-----|----|------|-------|
| L126.050.R | L126.050.L | 5 | 27 | 57,5 | 10X20 |
| L126.060.R | L126.060.L | 6 | 27 | 57,5 | 10X20 |
| L126.080.R | L126.080.L | 8 | 27 | 57,5 | 10X20 |
| | | | | | |
| L127.045.R | L127.045.L | 4,5 | 40 | 70 | 10X20 |
| L127.050.R | L127.050.L | 5 | 40 | 70 | 10X20 |
| L127.055.R | L127.055.L | 5,5 | 40 | 70 | 10X20 |
| L127.060.R | L127.060.L | 6 | 40 | 70 | 10X20 |
| L127.070.R | L127.070.L | 7 | 40 | 70 | 10X20 |
| L127.080.R | L127.080.L | 8 | 40 | 70 | 10X20 |
| L127.090.R | L127.090.L | 9 | 40 | 70 | 10X20 |
| L127.100.R | L127.100.L | 10 | 40 | 70 | 10X20 |
| L127.120.R | L127.120.L | 12 | 40 | 70 | 10X20 |



Z051.302.R



On request Z051.505.R

HW THROUGH HOLE DOWEL DRILLS WITH 2 AND 4 FLUTES (from art. L121 to L127)

How to determine the feeding speed according to the machine (RPM):

- Referred to a standard common diameter

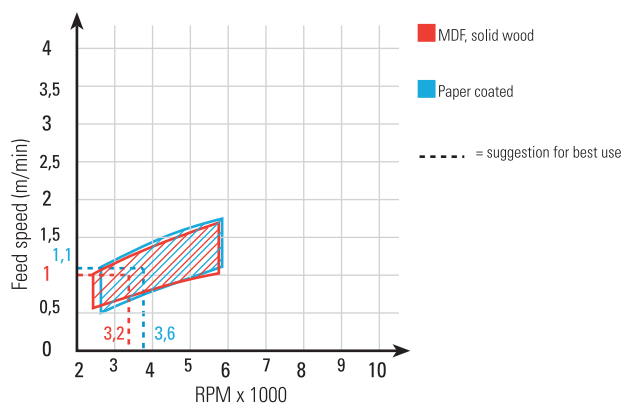
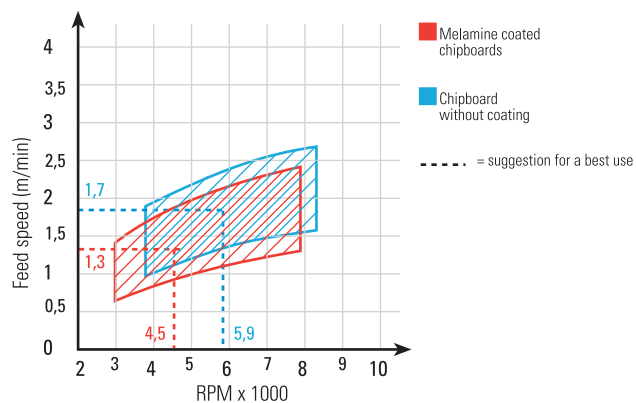

- Finish quality will be improved reducing the feed before the drill exit from the panel bottom side
- The solid carbide drills art. L129 allow the same results at higher feed speed and RPM

VHW THROUGH HOLE DRILL BITS Z=2

ART. L129

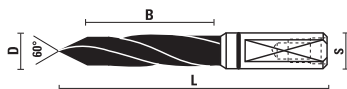

- Solid carbide spiral portion (with 2-flutes)
- For natural wood, pressed wood, veneered, chipboard, laminated and MDF
- Made with an exclusive carbide and a **mirror finish quality**. This process will reduce the friction and produce clean and smooth cuts with longer tool life and better performances.
- Best choice when working panels with special coating

| RH rotation | LH rotation | D | B | L | S |
|-----------------------|-----------------------|---|----|----|-------|
| L129.030.R NEW | L129.030.L NEW | 3 | 20 | 70 | 10x30 |
| L129.040.R NEW | L129.040.L NEW | 4 | 30 | 70 | 10x30 |
| L129.050.R | L129.050.L | 5 | 30 | 70 | 10x30 |
| L129.060.R | L129.060.L | 6 | 30 | 70 | 10x30 |
| L129.080.R | L129.080.L | 8 | 30 | 70 | 10x30 |



Z051.302.R



Z059.001.L



Z059.001.R

On request



Z051.505.R

VHW THROUGH HOLE DRILL BITS Z=2, Klein^{DIA} COATED

ART. L129.KD

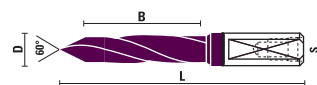

Tool life 4 times longer than uncoated tools

- Solid carbide spiral portion (with 2-flutes)
- Excellent finish and longer tool life
- Polished and coated cutting edge for improved chip evacuation and less friction
- For natural wood, pressed wood, veneered, chipboard, laminated and MDF
- Best choice when working panels with special coating

| RH rotation | LH rotation | D | B | L | S |
|-------------------------|-------------------------|---|----|----|-------|
| L129.050.RKD NEW | L129.050.LKD NEW | 5 | 30 | 70 | 10x30 |



Z051.302.R



Z059.001.L



Z059.001.R

On request



Z051.505.R

THE NEW COATED BITS FOR LARGE SCALE INDUSTRY



- DLC DIAMOND ANTIFRICTION COATING
- LONGER TOOL LIFE
- EXCELLENT PERFORMANCE ON EVERY KIND OF MATERIAL
- GREATER PRODUCTIVITY

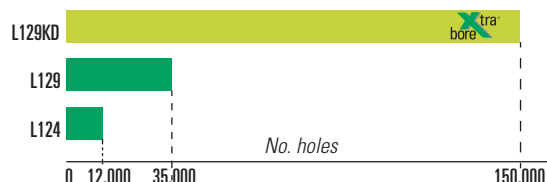

CONTACT US

(+39) 0721 28950

info@sistemiklein.com

HW COUNTERSINKS Z=2 - 90°

ART. L130

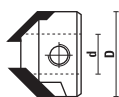

- For 4 Flutes drills:
Articles L103, L104, M101, M102, M103, M121, M122, M123,
N101, N111, N135, N136
- Adjustable on the cutting length

| RH rotation | LH rotation | d | D |
|-------------|-------------|---|------|
| L130.040.R | L130.040.L | 4 | 15,5 |
| L130.050.R | L130.050.L | 5 | 15,5 |



Z051.303.R

| | | | |
|------------|------------|-----|------|
| L130.060.R | L130.060.L | 6 | 15,5 |
| L130.064.R | L130.064.L | 6,4 | 15,5 |
| L130.070.R | L130.070.L | 7 | 18 |
| L130.080.R | L130.080.L | 8 | 18 |
| L130.090.R | L130.090.L | 9 | 18 |
| L130.100.R | L130.100.L | 10 | 20 |
| L130.120.R | L130.120.L | 12 | 22 |



Z051.300.R

HW COUNTERSINKS Z=2 - 90°

ART. L131



- For Articles L105, L106, L107, L108
- To be mounted on the shank \varnothing 10

| RH rotation | LH rotation | d | D |
|-------------|-------------|-------|----|
| L131.100.R | L131.100.L | 5/10 | 20 |
| L131.120.R | L131.120.L | 11/12 | 22 |



Z051.304.R

VHW DOWEL DRILLS FOR BOTH RIGHT HAND AND LEFT HAND ROTATION Z=1

ART. L136 - L137

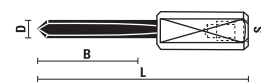

- Solid carbide spiral portion
- Straight cutting edges
- Can be used on either right and left rotation chucks
- Ideal for drilling highly **abrasive material**

| Item | D | B | L | S |
|------------|-----|----|------|-------|
| L136.020.N | 2 | 12 | 57,5 | 10x33 |
| L136.025.N | 2,5 | 15 | 57,5 | 10x33 |
| L136.030.N | 3 | 16 | 57,5 | 10x30 |
| L136.035.N | 3,5 | 18 | 57,5 | 10x30 |
| L136.040.N | 4 | 20 | 57,5 | 10x30 |
| L136.050.N | 5 | 25 | 57,5 | 10x25 |
| L136.060.N | 6 | 25 | 57,5 | 10x25 |
| L136.080.N | 8 | 25 | 57,5 | 10x25 |
| L137.020.N | 2 | 12 | 70 | 10x33 |
| L137.025.N | 2,5 | 12 | 70 | 10x33 |
| L137.030.N | 3 | 24 | 70 | 10x30 |
| L137.035.N | 3,5 | 30 | 70 | 10x30 |
| L137.040.N | 4 | 32 | 70 | 10x30 |
| L137.050.N | 5 | 35 | 70 | 10x25 |
| L137.060.N | 6 | 35 | 70 | 10x25 |
| L137.080.N | 8 | 35 | 70 | 10x25 |



Z051.302.R

On request Z051.505.R

HW DOWEL DRILLS WITH COUNTERSINK Z=2

ART. L138 - L139

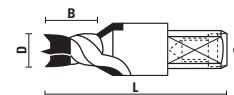

- Spurs ground with negative cutting angle for a good finish
- Cylindrical shank with flat/screw

| RH rotation | LH rotation | D | B | L | S |
|-------------|-------------|----|----|------|-------|
| L138.080.R | L138.080.L | 8 | 12 | 57,5 | 10x20 |
| L138.081.R | L138.081.L | 8 | 15 | 57,5 | 10x20 |
| L138.082.R | L138.082.L | 8 | 20 | 57,5 | 10x20 |
| L138.100.R | L138.100.L | 10 | 12 | 57,5 | 10x20 |
| L138.101.R | L138.101.L | 10 | 15 | 57,5 | 10x20 |
| L138.102.R | L138.102.L | 10 | 20 | 57,5 | 10x20 |
| L139.080.R | L139.080.L | 8 | 12 | 70 | 10x20 |
| L139.081.R | L139.081.L | 8 | 15 | 70 | 10x20 |
| L139.082.R | L139.082.L | 8 | 20 | 70 | 10x20 |
| L139.100.R | L139.100.L | 10 | 12 | 70 | 10x20 |
| L139.101.R | L139.101.L | 10 | 15 | 70 | 10x20 |
| L139.102.R | L139.102.L | 10 | 20 | 70 | 10x20 |



Z051.302.R

HW THROUGH HOLE DRILL BITS "E.T." LINE Z=2

ART. L132 - L133

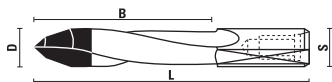

- **EXTRA TIME GRINDING TOOL**
- **High performance** with the special **double angle grinding geometry for smoother cuts**
- **PTFE-Based coating** for a better chip flow
- For **natural wood, pressed wood, veneered, chipboard, laminated and MDF**
- With height adjustment screw. On request it is possible to have the special screw for the Weeke Machines (Art. Z051.505.R)

| RH rotation | LH rotation | D | B | L | S |
|-------------|-------------|-----|----|----|-------|
| L132.050.R | L132.050.L | 5 | 30 | 58 | 10x24 |
| L132.060.R | L132.060.L | 6 | 30 | 58 | 10x24 |
| L132.080.R | L132.080.L | 8 | 30 | 58 | 10x24 |
| | | | | | |
| L133.040.R | L133.040.L | 4 | 36 | 70 | 10x24 |
| L133.050.R | L133.050.L | 5 | 36 | 70 | 10x24 |
| L133.060.R | L133.060.L | 6 | 36 | 70 | 10x24 |
| L133.064.R | L133.064.L | 6,4 | 36 | 70 | 10x24 |
| L133.070.R | L133.070.L | 7 | 36 | 70 | 10x24 |
| L133.080.R | L133.080.L | 8 | 36 | 70 | 10x24 |
| L133.100.R | L133.100.L | 10 | 36 | 70 | 10x24 |
| L133.120.R | L133.120.L | 12 | 36 | 70 | 10x24 |



Z051.302.R

On request



Z051.505.R

HW AND VH W THROUGH HOLE DOWEL DRILLS "E.T." EXTRA TIME (art. L132 - L133)

How to determine the feeding speed according to the machine (RPM):

- Referred to a standard common diameter

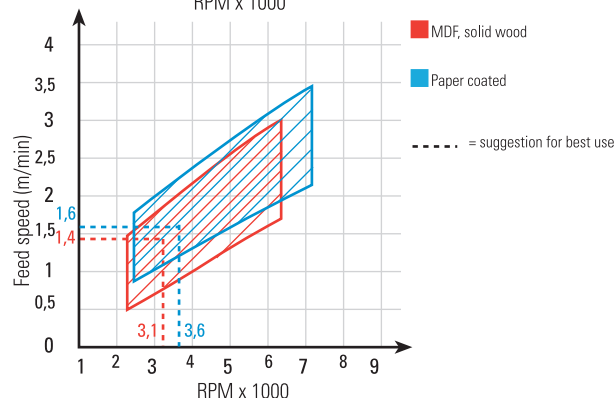
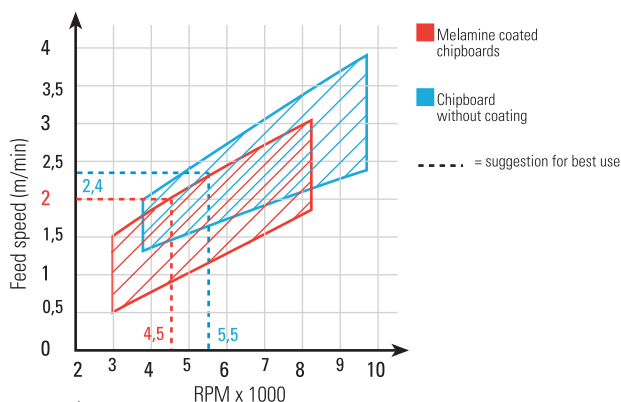

- Excellent finish result at high feed speed
- Use the solid carbide drills art. L134-L135 for the same result at higher feed speed and RPM

VHW THROUGH HOLE DRILL BITS "E.T." LINE Z=2

ART. L134 - L135

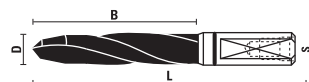

- **EXTRA TIME GRINDING TOOL**
- Made with an exclusive carbide and a mirror finish quality. This process will reduce the friction and produce clean and smooth cuts with longer tool life and better performances
- Solid carbide spiral portion
- **High performance** with the special **double angle grinding geometry for smoother cuts**
- For natural wood, pressed wood, veneered, chipboard, laminated and MDF
- With height adjustment screw. On request it is possible to have the special screw for the Weeke Machines (Art. Z051.505.R)

| RH rotation | LH rotation | D | B | L | S |
|-------------|-------------|-----|----|----|-------|
| L134.050.R | L134.050.L | 5 | 28 | 58 | 10x20 |
| L134.060.R | L134.060.L | 6 | 28 | 58 | 10x20 |
| L134.080.R | L134.080.L | 8 | 28 | 58 | 10x20 |
| | | | | | |
| L135.040.R | L135.040.L | 4 | 40 | 70 | 10x20 |
| L135.050.R | L135.050.L | 5 | 40 | 70 | 10x20 |
| L135.060.R | L135.060.L | 6 | 40 | 70 | 10x20 |
| L135.064.R | L135.064.L | 6,4 | 40 | 70 | 10x20 |
| L135.070.R | L135.070.L | 7 | 40 | 70 | 10x20 |
| L135.080.R | L135.080.L | 8 | 40 | 70 | 10x20 |



Z051.302.R



Z059.001.L



Z059.001.R

On request



Z051.505.R

VHW THROUGH HOLE DRILL BITS Z=2 "E.T." LINE, Klein^{DIA} COATED

ART. L134.KD - L135.KD

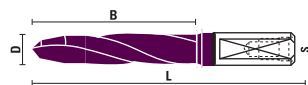

Xtra[®]
bore

Tool life 4 times longer than uncoated tools

- **EXTRA TIME** grinding tool (**high performance** thanks to the double angle geometry)
- **Solid carbide spiral portion** (with 2 flutes)
- **Polished and coated cutting edge for improved chip evacuation and less friction**
- **Excellent finish and longer tool life**
- **High performance** thanks to its double angle geometry
- **Special HW** more resistant
- For natural and pressed wood, veneered and laminated panels, chipboard and MDF

| RH rotation | LH rotation | D | B | L | S |
|-------------------------|-------------------------|---|----|----|-------|
| L134.050.RKD NEW | L134.050.LKD NEW | 5 | 28 | 58 | 10x20 |
| L134.080.RKD NEW | L134.080.LKD NEW | 8 | 28 | 58 | 10x20 |
| | | | | | |
| L135.040.RKD NEW | L135.040.LKD NEW | 4 | 40 | 70 | 10x20 |
| L135.050.RKD NEW | L135.050.LKD NEW | 5 | 40 | 70 | 10x20 |
| L135.060.RKD NEW | L135.060.LKD NEW | 6 | 40 | 70 | 10x20 |
| L135.080.RKD NEW | L135.080.LKD NEW | 8 | 40 | 70 | 10x20 |



Z051.302.R



Z059.001.L



Z059.001.R

On request



Z051.505.R

HW HINGE BORING BITS Z=2+2

ART. L140 - L141

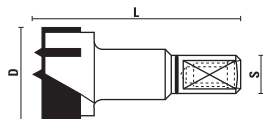

For natural and pressed woods, chipboards, veneered and laminate coated panels and MDF

| RH rotation | LH rotation | D | L | S |
|-------------|-------------|----|----|-------|
| L140.150.R | L140.150.L | 15 | 57 | 10X26 |
| L140.160.R | L140.160.L | 16 | 57 | 10X26 |
| L140.170.R | L140.170.L | 17 | 57 | 10X26 |
| L140.180.R | L140.180.L | 18 | 57 | 10X26 |
| L140.190.R | L140.190.L | 19 | 57 | 10X26 |
| L140.200.R | L140.200.L | 20 | 57 | 10X26 |
| L140.220.R | L140.220.L | 22 | 57 | 10X26 |
| L140.240.R | L140.240.L | 24 | 57 | 10X26 |
| L140.250.R | L140.250.L | 25 | 57 | 10X26 |
| L140.260.R | L140.260.L | 26 | 57 | 10X26 |
| L140.280.R | L140.280.L | 28 | 57 | 10X26 |
| L140.300.R | L140.300.L | 30 | 57 | 10X26 |
| L140.320.R | L140.320.L | 32 | 57 | 10X26 |
| L140.340.R | L140.340.L | 34 | 57 | 10X26 |
| L140.350.R | L140.350.L | 35 | 57 | 10X26 |
| L140.360.R | L140.360.L | 36 | 57 | 10X26 |
| L140.380.R | L140.380.L | 38 | 57 | 10X26 |
| L140.400.R | L140.400.L | 40 | 57 | 10X26 |

| | | | | |
|------------|------------|----|----|-------|
| L141.150.R | L141.150.L | 15 | 70 | 10X26 |
| L141.160.R | L141.160.L | 16 | 70 | 10X26 |
| L141.180.R | L141.180.L | 18 | 70 | 10X26 |
| L141.200.R | L141.200.L | 20 | 70 | 10X26 |
| L141.220.R | L141.220.L | 22 | 70 | 10X26 |
| L141.250.R | L141.250.L | 25 | 70 | 10X26 |
| L141.260.R | L141.260.L | 26 | 70 | 10X26 |
| L141.300.R | L141.300.L | 30 | 70 | 10X26 |
| L141.340.R | L141.340.L | 34 | 70 | 10X26 |
| L141.350.R | L141.350.L | 35 | 70 | 10X26 |
| L141.400.R | L141.400.L | 40 | 70 | 10X26 |



HW HINGE BORING BITS Z=2+2

ART. L142

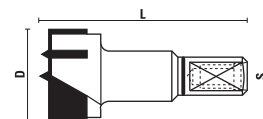

For natural and pressed woods, chipboards, veneered and laminate coated panels and MDF

| RH rotation | LH rotation | D | L | S |
|-------------|-------------|----|----|-------|
| L142.200.R | L142.200.L | 20 | 77 | 10X26 |
| L142.250.R | L142.250.L | 25 | 77 | 10X26 |
| L142.300.R | L142.300.L | 30 | 77 | 10X26 |
| L142.350.R | L142.350.L | 35 | 77 | 10X26 |



HW HINGE BORING BITS Z=2+2

ART. L150 - L151

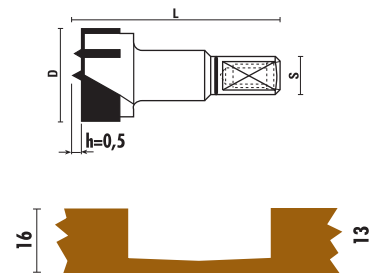

- Centerpoint H=0,5 mm for thin boards (16 mm)
- For natural and pressed woods, chipboards, veneered and laminate coated panels and MDF

| RH rotation | LH rotation | D | L | S |
|-------------|-------------|----|----|-------|
| L150.150.R | L150.150.L | 15 | 56 | 10X26 |
| L150.200.R | L150.200.L | 20 | 56 | 10X26 |
| L150.350.R | L150.350.L | 35 | 56 | 10X26 |

| | | | | |
|------------|------------|----|----|-------|
| L151.150.R | L151.150.L | 15 | 70 | 10X26 |
| L151.200.R | L151.200.L | 20 | 70 | 10X26 |
| L151.350.R | L151.350.L | 35 | 70 | 10X26 |



HW HINGE BORING BITS Z=2+2 (ART. L140-L141-L142-L150-L151)

How to determine the feeding speed according to the machine (RPM):

- Referred to a standard common diameter

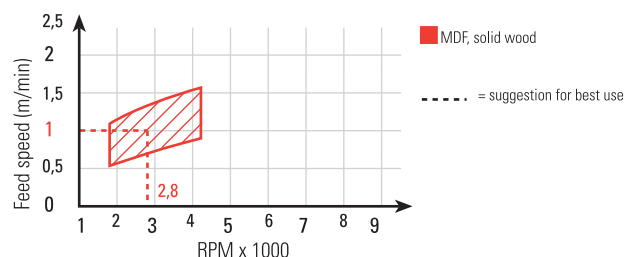
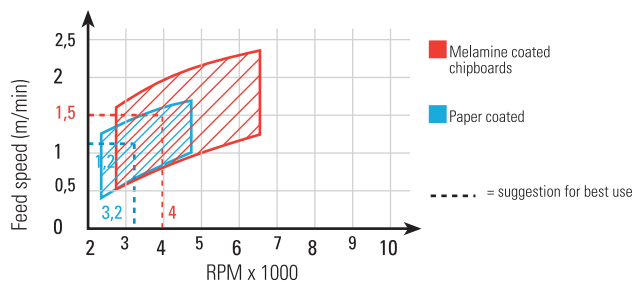

HW HINGE BORING BITS Z=3+3

ART. L143 - L144

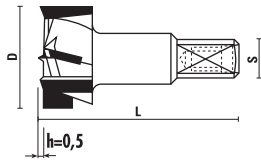

Centerpoint H=0,5 mm

| RH rotation | LH rotation | D | L | S |
|-------------|-------------|----|------|-------|
| L143.250.R | L143.250.L | 25 | 57,5 | 10x26 |
| L143.260.R | L143.260.L | 26 | 57,5 | 10x26 |
| L143.300.R | L143.300.L | 30 | 57,5 | 10x26 |
| L143.350.R | L143.350.L | 35 | 57,5 | 10x26 |
| L143.400.R | L143.400.L | 40 | 57,5 | 10x26 |



Z051.302.R



Without centerpoint

| RH rotation | LH rotation | D | L | S |
|-------------|-------------|----|------|-------|
| L144.250.R | L144.250.L | 25 | 57,5 | 10x26 |
| L144.260.R | L144.260.L | 26 | 57,5 | 10x26 |
| L144.300.R | L144.300.L | 30 | 57,5 | 10x26 |
| L144.350.R | L144.350.L | 35 | 57,5 | 10x26 |



Z051.302.R

HW HINGE BORING BITS Z=3+3 (art. L143-L144)

How to determine the feeding speed according to the machine (RPM):

- Referred to a standard common diameter

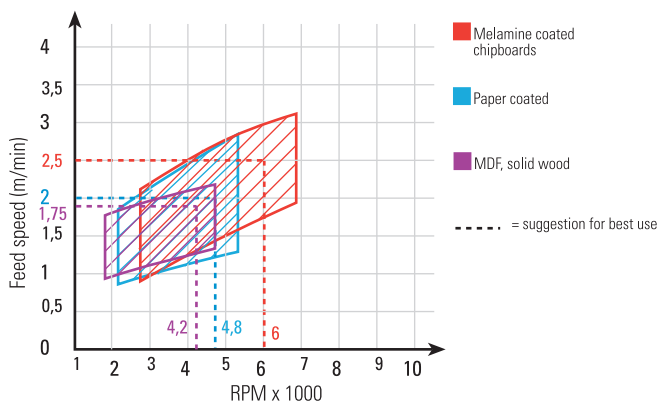

VHW HINGE BORING BITS Z=2+2

ART. L155 - L156

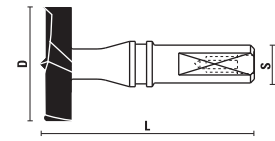

- Solid carbide
- Rounded spurs for an excellent finish
- Highest performance also in extreme conditions
- For high precision bores for hinges
- Ideal for hard and soft wood, chipboard, MDF, veneered and plastic coated boards

| RH rotation | LH rotation | D | L | S |
|-------------|-------------|----|----|-------|
| L155.150.R | L155.150.L | 15 | 57 | 10x26 |
| L155.200.R | L155.200.L | 20 | 57 | 10x26 |
| L155.250.R | L155.250.L | 25 | 57 | 10x26 |
| L155.300.R | L155.300.L | 30 | 57 | 10x26 |
| L155.350.R | L155.350.L | 35 | 57 | 10x26 |

| | | | | |
|------------|------------|----|----|-------|
| L156.150.R | L156.150.L | 15 | 70 | 10x26 |
| L156.200.R | L156.200.L | 20 | 70 | 10x26 |
| L156.250.R | L156.250.L | 25 | 70 | 10x26 |
| L156.300.R | L156.300.L | 30 | 70 | 10x26 |
| L156.350.R | L156.350.L | 35 | 70 | 10x26 |



Z051.302.R

VHW HINGE BORING BITS Z=2+2 (art. L155-L156)

How to determine the feeding speed according to the machine (RPM):

- Referred to a standard common diameter

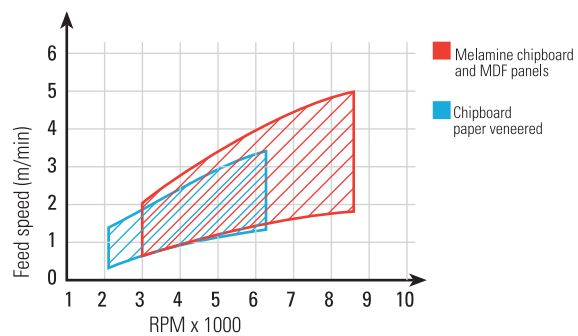

HW HINGE BORING BITS Z=2+2

ART. L160

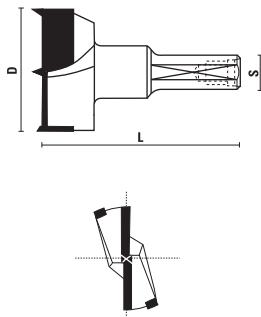

To be used on Trimatic 22-25-28

| RH rotation | LH rotation | D | L | S |
|-------------|-------------|----|----|-------|
| L160.300.R | L160.300.L | 30 | 57 | 10X26 |
| L160.340.R | L160.340.L | 34 | 57 | 10X26 |



Z051.302.R

HW HINGE BORING BITS Z=2+2

ART. L170

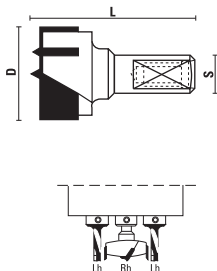

To be used on Trimatic Super

| RH rotation | LH rotation | D | L | S |
|-------------|-------------|----|------|-------|
| L170.200.R | L170.200.L | 20 | 38,5 | 10X22 |
| L170.260.R | | 26 | 38,5 | 10X22 |
| L170.350.R | L170.350.L | 35 | 38,5 | 10X22 |
| L170.400.R | | 40 | 38,5 | 10X22 |



Z051.302.R

HW DOWEL DRILLS Z=2

ART. L171

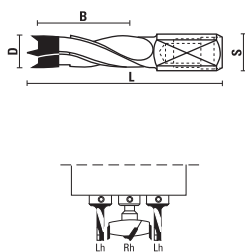

- To be used on Trimatic Super
- PTFE-Based coating for a better chip flow
- For natural and pressed woods, chipboards and laminate coated panels

| RH rotation | LH rotation | D | B | L | S |
|-------------|-------------|----|----|------|-------|
| L171.050.R | L171.050.L | 5 | 18 | 38,5 | 10X18 |
| L171.080.R | L171.080.L | 8 | 18 | 38,5 | 10X18 |
| L171.100.R | L171.100.L | 10 | 18 | 38,5 | 10X18 |



Z051.302.R

HW DRILLS FOR CABINEO® Z=2

ART. L174



L174.150.R



L174.150.L

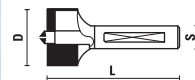

To be used on Trimatic 22,4 for Cabineo®

| RH rotation | LH rotation | D | L | S |
|-----------------------|-----------------------|----|----|---|
| L174.150.R NEW | L174.150.L NEW | 15 | 35 | 6 |

TRIMATIC 22,4 FOR "LAMELLO® CABINEO®"



trimatic®

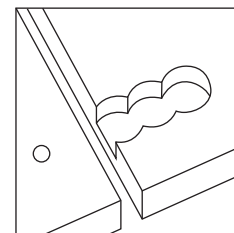

See catalogue section 16
at page 16.11

DRILLING JIG FOR MAKING HOLES FOR HINGE INSERTING

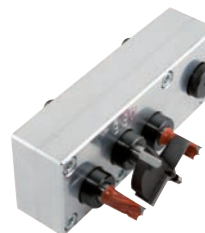
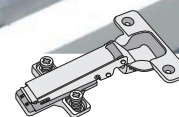

trimatic®

See catalogue section 16
at page 16.12

HW DOWEL DRILLS WITH THREADED SHANK Z=2

ART. M101 - M102 - M103

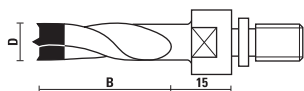

- 4-flutes
- M10/11x4 for: MORBIDELLI - BIESSE - WEEKE

| RH rotation | LH rotation | D | B |
|-------------|-------------|----|----|
| M101.050.R | M101.050.L | 5 | 30 |
| M101.060.R | M101.060.L | 6 | 30 |
| M101.080.R | M101.080.L | 8 | 30 |
| M101.100.R | M101.100.L | 10 | 30 |
| M101.120.R | M101.120.L | 12 | 30 |
| M101.140.R | M101.140.L | 14 | 30 |
| | | | |
| M102.050.R | M102.050.L | 5 | 40 |
| M102.060.R | M102.060.L | 6 | 40 |
| M102.080.R | M102.080.L | 8 | 40 |
| M102.100.R | M102.100.L | 10 | 40 |
| M102.120.R | M102.120.L | 12 | 40 |
| M102.140.R | M102.140.L | 14 | 40 |
| | | | |
| M103.050.R | M103.050.L | 5 | 50 |
| M103.060.R | M103.060.L | 6 | 50 |
| M103.080.R | M103.080.L | 8 | 50 |
| M103.100.R | M103.100.L | 10 | 50 |
| M103.120.R | M103.120.L | 12 | 50 |
| M103.140.R | M103.140.L | 14 | 50 |

HW DOWEL DRILLS WITH COUNTERSINK THREADED SHANK Z=2

ART. M111 - M112 - M113

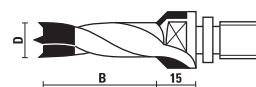

- 2-flutes
- M10/11x4 for: MORBIDELLI - BIESSE - WEEKE

| RH rotation | LH rotation | D | B |
|-------------|-------------|----|----|
| M111.050.R | M111.050.L | 5 | 30 |
| M111.060.R | M111.060.L | 6 | 30 |
| M111.080.R | M111.080.L | 8 | 30 |
| M111.100.R | M111.100.L | 10 | 30 |
| M111.120.R | M111.120.L | 12 | 30 |
| M111.140.R | M111.140.L | 14 | 30 |
| M111.160.R | M111.160.L | 16 | 30 |
| | | | |
| M112.050.R | M112.050.L | 5 | 40 |
| M112.060.R | M112.060.L | 6 | 40 |
| M112.080.R | M112.080.L | 8 | 40 |
| M112.100.R | M112.100.L | 10 | 40 |
| M112.120.R | M112.120.L | 12 | 40 |
| M112.140.R | M112.140.L | 14 | 40 |
| M112.160.R | M112.160.L | 16 | 40 |
| | | | |
| M113.050.R | M113.050.L | 5 | 50 |
| M113.060.R | M113.060.L | 6 | 50 |
| M113.080.R | M113.080.L | 8 | 50 |
| M113.100.R | M113.100.L | 10 | 50 |
| M113.120.R | M113.120.L | 12 | 50 |
| M113.140.R | M113.140.L | 14 | 50 |
| M113.160.R | M113.160.L | 16 | 50 |

visit our website

www.sistemiklein.com



HW DOWEL DRILLS WITH THREADED SHANK Z=2

ART. M121 - M122 - M123

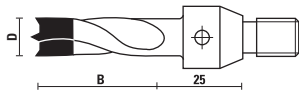

- 4-flutes
- M10/30° for: VITAP - BUSELLATO - SCHLEICHER

| RH rotation | LH rotation | D | B |
|-------------|-------------|----|----|
| M121.050.R | M121.050.L | 5 | 30 |
| M121.060.R | M121.060.L | 6 | 30 |
| M121.080.R | M121.080.L | 8 | 30 |
| M121.100.R | M121.100.L | 10 | 30 |
| M121.120.R | M121.120.L | 12 | 30 |
| M121.140.R | M121.140.L | 14 | 30 |
| | | | |
| M122.050.R | M122.050.L | 5 | 40 |
| M122.060.R | M122.060.L | 6 | 40 |
| M122.080.R | M122.080.L | 8 | 40 |
| M122.100.R | M122.100.L | 10 | 40 |
| M122.120.R | M122.120.L | 12 | 40 |
| M122.140.R | M122.140.L | 14 | 40 |
| | | | |
| M123.050.R | M123.050.L | 5 | 50 |
| M123.060.R | M123.060.L | 6 | 50 |
| M123.080.R | M123.080.L | 8 | 50 |
| M123.100.R | M123.100.L | 10 | 50 |
| M123.120.R | M123.120.L | 12 | 50 |
| M123.140.R | M123.140.L | 14 | 50 |

HW DOWEL DRILLS WITH COUNTERSINK THREADED SHANK Z=2

ART. M131 - M132

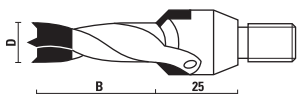

- 2-flutes
- M10/30° for: VITAP - BUSELLATO - SCHLEICHER

| RH rotation | LH rotation | D | B |
|-------------|-------------|----|----|
| M131.050.R | M131.050.L | 5 | 30 |
| M131.060.R | M131.060.L | 6 | 30 |
| M131.080.R | M131.080.L | 8 | 30 |
| M131.100.R | M131.100.L | 10 | 30 |
| M131.120.R | M131.120.L | 12 | 30 |
| M131.140.R | M131.140.L | 14 | 30 |
| M131.160.R | M131.160.L | 16 | 30 |
| | | | |
| M132.050.R | M132.050.L | 5 | 40 |
| M132.060.R | M132.060.L | 6 | 40 |
| M132.080.R | M132.080.L | 8 | 40 |
| M132.100.R | M132.100.L | 10 | 40 |
| M132.120.R | M132.120.L | 12 | 40 |
| M132.140.R | M132.140.L | 14 | 40 |
| M132.160.R | M132.160.L | 16 | 40 |

HW HINGE BORING BITS WITH THREADED SHANK Z=2

ART. M141 - M142

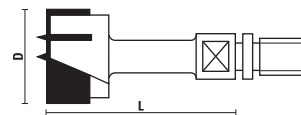

M10/11x4 for: MORBIDELLI - BIESSE - WEEKE

| RH rotation | LH rotation | D | L |
|-------------|-------------|----|----|
| M141.200.R | M141.200.L | 20 | 40 |
| M141.250.R | M141.250.L | 25 | 40 |
| M141.350.R | M141.350.L | 35 | 40 |
| M141.400.R | M141.400.L | 40 | 40 |
| | | | |
| M142.200.R | M142.200.L | 20 | 55 |
| M142.250.R | M142.250.L | 25 | 55 |
| M142.260.R | M142.260.L | 26 | 55 |
| M142.300.R | M142.300.L | 30 | 55 |
| M142.350.R | M142.350.L | 35 | 55 |
| M142.400.R | M142.400.L | 40 | 55 |

HW HINGE BORING BITS WITH THREADED SHANK Z=2+2

ART. M151

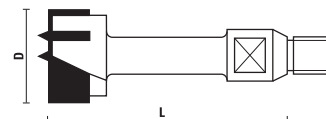

M10/30° for: VITAP - BUSELLATO - SCHLEICHER

| RH rotation | LH rotation | D | L |
|-------------|-------------|----|----|
| M151.250.R | M151.250.L | 25 | 65 |
| M151.260.R | M151.260.L | 26 | 65 |
| M151.350.R | M151.350.L | 35 | 65 |
| M151.400.R | M151.400.L | 40 | 65 |

HW HINGE BORING BITS WITH THREADED SHANK Z=2+2

ART. N121 - N131



- M8 for: NOTTMEYER
- M10 for: AYEN

| RH rotation | LH rotation | D | L | S |
|-------------|-------------|----|----|-----|
| N121.250.R | N121.250.L | 25 | 63 | M8 |
| N121.350.R | N121.350.L | 35 | 63 | M8 |
| | | | | |
| N131.200.R | N131.200.L | 20 | 63 | M10 |
| N131.250.R | N131.250.L | 25 | 63 | M10 |
| N131.350.R | N131.350.L | 35 | 63 | M10 |

HW DOWEL DRILLS WITH THREADED SHANK Z=2

ART. N101 - N111

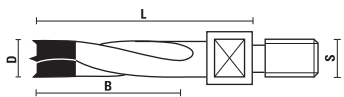

- 4-flutes
- M8 for: **NOTTMEYER**
- M10 for: **AYEN**

| RH rotation | LH rotation | D | B | L | S |
|-------------|-------------|----|----|----|-----|
| N101.050.R | N101.050.L | 5 | 43 | 63 | M8 |
| N101.060.R | N101.060.L | 6 | 43 | 63 | M8 |
| N101.080.R | N101.080.L | 8 | 43 | 63 | M8 |
| N101.100.R | N101.100.L | 10 | 43 | 63 | M8 |
| N101.120.R | N101.120.L | 12 | 43 | 63 | M8 |
| N111.050.R | N111.050.L | 5 | 43 | 63 | M10 |
| N111.060.R | N111.060.L | 6 | 43 | 63 | M10 |
| N111.080.R | N111.080.L | 8 | 43 | 63 | M10 |
| N111.100.R | N111.100.L | 10 | 43 | 63 | M10 |
| N111.120.R | N111.120.L | 12 | 43 | 63 | M10 |

HW COUNTERBORE BITS

ART. N150

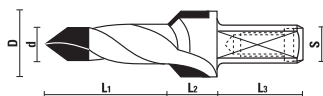

Features requested: dxL1 - DxL2 - SxL3

| RH rotation | LH rotation | D | |
|-------------|-------------|----|----|
| N150.000.R | N150.000.L | 10 | HW |
| N150.000.R | N150.000.L | 12 | HW |
| N150.000.R | N150.000.L | 15 | HW |
| N150.000.R | N150.000.L | 20 | HW |
| N150.000.R | N150.000.L | 25 | HW |
| N150.000.R | N150.000.L | 30 | HW |
| N150.000.R | N150.000.L | 35 | HW |
| N150.000.R | N150.000.L | 40 | HW |

HW DOWEL DRILLS WITH THREADED SHANK Z=2

ART. N135 - N136

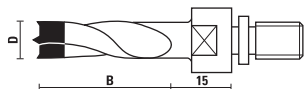

- 4-flutes
- M8/9x4 for: **MORBIDELLI, NOTTMEYER, MASTERWOOD**

| RH rotation | LH rotation | D | B |
|-------------|-------------|----|----|
| N135.050.R | N135.050.L | 5 | 40 |
| N135.060.R | N135.060.L | 6 | 40 |
| N135.080.R | N135.080.L | 8 | 40 |
| N135.100.R | N135.100.L | 10 | 40 |
| N135.120.R | N135.120.L | 12 | 40 |
| N136.050.R | N136.050.L | 5 | 60 |
| N136.060.R | N136.060.L | 6 | 60 |
| N136.080.R | N136.080.L | 8 | 60 |
| N136.100.R | N136.100.L | 10 | 60 |
| N136.120.R | N136.120.L | 12 | 60 |

MODULAR DRAWER UNIT

Drawer unit

"Elegant, sturdy **Klein** drawer unit with an innovative, modern design and great modularity, where you can keep all your **Klein** tools in a clean, secure, well-organized place. Say good-bye to messiness and damaged tools. Now, with the new **Klein** drawer unit, you can put your storeroom in order in a convenient, functional way.



SMALL OUTSIDE BUT LARGE INSIDE
the **Klein** drawer unit takes up little space but can contain countless articles in its 10 drawers and 80 containers (8 containers per drawer).

- **STURDY**
since each drawer can hold around 8 kg.
- **LIGHT**
since it's made of a high-strength polypropylene co-polymer.
- **SECURE**
since each drawer has its own key.
- **PRACTICAL**
since it can be equipped with 4 casters for convenient movement or with slip-resistant feet.
- **CONVENIENT**
since it features a wooden top which acts as a practical surface for taking notes or keeping tools.
- **VERSATILE**
since the tubs in the drawers can be removed easily as desired.

Whether it's placed next to a CNC router, or close to a point-to-point boring machine, along the panel production line or in any carpentry shop, the new **Klein** drawer unit can be a real help in keeping the tools you use every day in perfect order and in good condition.



The new **Klein** drawer unit can hold a wide range of tools.
Ask our customer service how to receive it.

Modular drawer unit "Boring Machine"

Ideal to store dowel drills and boring bits beside your boring machine



1st Drawer
Drill holders

- Art. L001.100.R
- L001.100.L
- L002.100.R
- L002.100.L
- L030.100.R
- L030.100.L
- L031.100.R
- L032.100.R

2nd Drawer
Drills L=57,5

- Art. L103.040.R
- L103.040.L
- L103.050.R
- L103.050.L
- L103.060.R
- L103.060.L
- L103.070.R
- L103.070.L

3rd Drawer
Drills L=57,5

- Art. L103.080.R
- L103.080.L
- L103.100.R
- L103.100.L
- L103.120.R
- L103.120.L
- L103.140.R
- L103.140.L

4th Drawer
Drills L=70

- Art. L104.040.R
- L104.040.L
- L104.050.R
- L104.050.L
- L104.060.R
- L104.060.L
- L104.070.R
- L104.070.L

5th Drawer
Drills L=70

- Art. L104.080.R
- L104.080.L
- L104.100.R
- L104.100.L
- L104.120.R
- L104.120.L
- L104.140.R
- L104.140.L

6th Drawer
Through hole drills

- Art. L124.050.R
- L124.050.L
- L124.060.R
- L124.060.L
- L124.080.R
- L124.080.L
- L124.100.R
- L124.100.L

7th Drawer
Hinge boring bits

- Art. L140.150.R
- L140.150.L
- L140.180.R
- L140.180.L
- L140.200.R
- L140.200.L
- L140.250.R
- L140.250.L

8th Drawer
Hinge boring bits

- Art. L140.260.R
- L140.260.L
- L140.300.R
- L140.300.L
- L140.350.R
- L140.350.L
- L140.400.R
- L140.400.L

9th Drawer
High performance drills L=57,5

- Art. L114.050.R
- L114.050.L
- L114.060.R
- L114.060.L
- L114.080.R
- L114.080.L
- L114.100.R
- L114.100.L

10th Drawer
High performance drills L=70

- Art. L115.050.R
- L115.050.L
- L115.060.R
- L115.060.L
- L115.080.R
- L115.080.L
- L115.100.R
- L115.100.L

Boring bits, slot mortising bits



6



HW FLAT COUNTERSINKS Z=2
Page 6.03



HW SPIRAL BITS Z=2
Page 6.03



HW COUNTERSINK Z=2 - 30°
Page 6.03



HW SPIRAL BITS Z=2
Page 6.03



HS COUNTERSINKS Z=2
Page 6.03



HS BRAD POINT DRILLS Z=2
Page 6.04



SP BRAD POINT DRILLS Z=2
Page 6.04

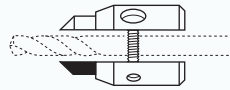

HW ADJUSTABLE COUNTERSINK Z=2
Page 6.04



SP BRAD POINT DRILLS Z=2
Page 6.04



**SP SINGLE FLUTE DRILLS "LEWIS"
TYPE Z=1**
Page 6.05



HS SPIRAL BITS Z=2
Page 6.05



HS SPIRAL BITS Z=2
Page 6.05



HS STEP DRILLS Z=2
Page 6.05



HS STEP DRILLS Z=2
Page 6.06



**HW/HS 3-DIAMETER BITS
"CONFIRMAT" Z=2**
Page 6.06



**HW/HS 3-DIAMETER DRILLS,
ADJUSTABLE Z=2**
Page 6.06



HS TWIST DRILLS Z=2
Page 6.06



**HW ADJUSTABLE DIAMETER
BORING BITS 30/60 MM**
Page 6.07

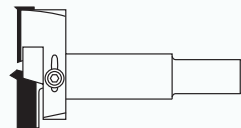

**HW ADJUSTABLE DIAMETER BORING
BITS 60/80 MM**
Page 6.07

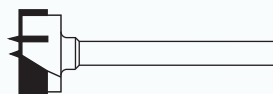

HW HINGE BORING BITS Z=2+2
Page 6.07

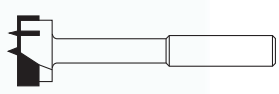

HW HINGE BORING BITS Z=2+2
Page 6.08

Klein®



6

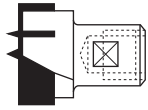

HW INTERCHANGEABLE HINGE BORING BITS Z=2+2
Page 6.08

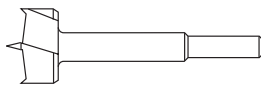

HS HINGE BORING BITS Z=2+2
Page 6.09

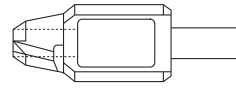

SP PLUG CUTTERS
Page 6.09

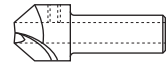

HW/HS COUNTERSINKS Z=2
Page 6.09

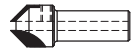

HW COUNTERSINKS 45° Z=2 WITH SHANK S=8
Page 6.10

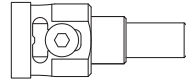

ADJUSTABLE DEPTH STOPPER
Page 6.10

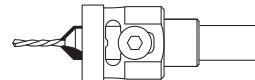

ADJUSTABLE COUNTERSINK SET
Page 6.10



HW COUNTERSINKS 45° Z=2 WITH HEX SHANK
Page 6.11



ADJUSTABLE DEPTH STOPPER
Page 6.11

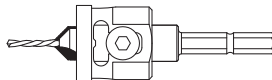

ADJUSTABLE COUNTERSINK SET
Page 6.11

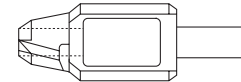

HS PLUG CUTTERS Z=1
Page 6.11



HS SPIRAL BITS Z=2
Page 6.11



HW/HS DOVETAIL BITS 9° - Z=1
Page 6.12



VHW DOVETAIL BITS Z=2
Page 6.12

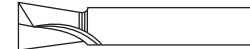

HW/HS DOVETAIL BITS Z=2
Page 6.12



SP SLOT MORTISING BITS WITH CHIPBREAKER Z=2
Page 6.12



HL RECIPROCATING SLOT MORTISING BITS
Page 6.13



HL RECIPROCATING SLOT MORTISING BITS Z=3
Page 6.13



HW RECIPROCATING SLOT MORTISING BITS
Page 6.13



HW/SP GROOVING CUTTERS Z=2
Page 6.13



HW/SP SLOT MORTISING CUTTERS Z=2
Page 6.13

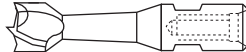

HW/SP BORING BITS Z=2
Page 6.14



HW/SP SLOT BORING BITS Z=2
Page 6.14

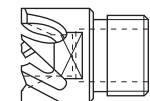

HS DOWEL CUTTERS
Page 6.14



HS CUTTERS FOR COPYING LATHES
Page 6.14

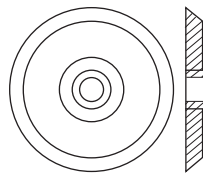

HS CUTTERS FOR COPYING LATHES
Page 6.14

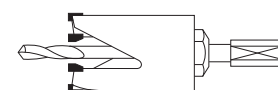

HW HOLE SAWS
Page 6.15

HW FLAT COUNTERSINKS Z=2

ART. R100

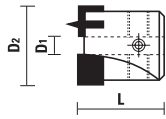

- Use with Art. R101 and with T.C.T. dowel drills Art. L103 - L104 - L109 - L110 and with all dowel drills with 4 flutes

| RH rotation | LH rotation | D1 | D2 | L |
|-------------|-------------|----|----|----|
| R100.050.R | R100.050.L | 5 | 16 | 20 |
| R100.060.R | R100.060.L | 6 | 16 | 20 |
| R100.061.R | R100.061.L | 6 | 20 | 20 |
| R100.070.R | R100.070.L | 7 | 20 | 20 |
| R100.080.R | R100.080.L | 8 | 16 | 20 |
| R100.081.R | R100.081.L | 8 | 19 | 20 |
| R100.082.R | R100.082.L | 8 | 20 | 20 |
| R100.090.R | R100.090.L | 9 | 19 | 20 |
| R100.091.R | R100.091.L | 9 | 20 | 20 |
| R100.100.R | R100.100.L | 10 | 20 | 20 |
| R100.101.R | R100.101.L | 10 | 25 | 20 |
| R100.102.R | R100.102.L | 10 | 30 | 20 |
| R100.120.R | R100.120.L | 12 | 25 | 20 |
| R100.121.R | R100.121.L | 12 | 30 | 20 |

HW SPIRAL BITS Z=2

ART. R101

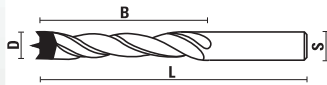

- 4-flutes
- Use rings Art. Z003 page 10.03

| RH rotation | D | B | L |
|-------------|----|-----|-----|
| R101.050.R | 5 | 50 | 85 |
| R101.060.R | 6 | 55 | 90 |
| R101.070.R | 7 | 65 | 105 |
| R101.080.R | 8 | 75 | 115 |
| R101.090.R | 9 | 80 | 125 |
| R101.100.R | 10 | 90 | 135 |
| R101.120.R | 12 | 100 | 150 |

HW COUNTERSINKS Z=2 - 30°

ART. R102

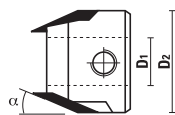

- Use with T.C.T. dowel drills Art. L103 - L104 - L109 - L110 and with all dowel drills with 4 flutes

| RH rotation | D1 | D2 | α |
|-------------|----|----|-----|
| R102.080.R | 8 | 19 | 30° |

HW SPIRAL BITS Z=2

ART. R125

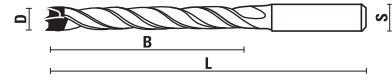

- 4-flutes
- Use rings Art. Z003 page 10.03

| RH rotation | D | B | L | S |
|-------------|----|-----|-----|-------|
| R125.060.R | 6 | 75 | 140 | 13x50 |
| R125.080.R | 8 | 85 | 150 | 13x50 |
| R125.100.R | 10 | 95 | 160 | 13x50 |
| R125.120.R | 12 | 105 | 170 | 13x50 |
| R125.130.R | 13 | 110 | 175 | 13x50 |
| R125.140.R | 14 | 115 | 180 | 13x50 |
| R125.150.R | 15 | 120 | 185 | 13x50 |
| R125.160.R | 16 | 125 | 190 | 16x50 |
| R125.180.R | 18 | 130 | 200 | 16x50 |
| R125.200.R | 20 | 140 | 210 | 16x50 |

HS COUNTERSINKS Z=2

ART. R200

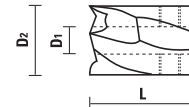

For Art. R201

| RH rotation | D1 | D2 | L |
|-------------|----|----|----|
| R200.040.R | 4 | 10 | 22 |
| R200.050.R | 5 | 12 | 22 |
| R200.051.R | 5 | 15 | 22 |
| R200.060.R | 6 | 15 | 22 |
| R200.061.R | 6 | 16 | 22 |
| R200.062.R | 6 | 20 | 22 |
| R200.080.R | 8 | 16 | 22 |
| R200.081.R | 8 | 20 | 22 |
| R200.082.R | 8 | 22 | 22 |
| R200.083.R | 8 | 25 | 22 |
| R200.100.R | 10 | 20 | 22 |
| R200.101.R | 10 | 25 | 25 |
| R200.102.R | 10 | 30 | 25 |
| R200.120.R | 12 | 25 | 25 |
| R200.121.R | 12 | 30 | 25 |

R200.910.R Set with 6 countersinks Ø 5/15 - 6/15 - 6/20 - 8/20 - 8/25 - 10/25 + 4 brad point drills Ø 5 - 6 - 8 - 10



HS BRAD POINT DRILLS Z=2

ART. R201

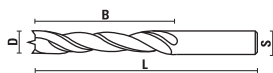

- 4-flutes
- Use rings Art. Z003 page 10.03

| RH rotation | D | B | L |
|-------------|-----|-----|-----|
| R201.060.R | 6 | 55 | 95 |
| R201.065.R | 6,5 | 65 | 105 |
| R201.070.R | 7 | 70 | 110 |
| R201.075.R | 7,5 | 70 | 115 |
| R201.080.R | 8 | 75 | 120 |
| R201.090.R | 9 | 80 | 130 |
| R201.100.R | 10 | 90 | 140 |
| R201.110.R | 11 | 95 | 150 |
| R201.120.R | 12 | 100 | 155 |

SP BRAD POINT DRILLS Z=2

ART. R205



2-flutes

| RH rotation | D | B | L | S |
|-------------|----|-----|-----|----|
| R205.030.R | 3 | 33 | 60 | 3 |
| R205.040.R | 4 | 43 | 75 | 4 |
| R205.050.R | 5 | 52 | 85 | 5 |
| R205.060.R | 6 | 57 | 93 | 6 |
| R205.070.R | 7 | 69 | 109 | 7 |
| R205.080.R | 8 | 75 | 117 | 8 |
| R205.090.R | 9 | 81 | 125 | 9 |
| R205.100.R | 10 | 87 | 133 | 10 |
| R205.111.R | 11 | 94 | 150 | 10 |
| R205.120.R | 12 | 101 | 155 | 10 |
| R205.130.R | 13 | 101 | 155 | 10 |
| R205.140.R | 14 | 108 | 170 | 10 |
| R205.150.R | 15 | 114 | 170 | 10 |
| R205.160.R | 16 | 120 | 180 | 10 |
| R205.180.R | 18 | 130 | 200 | 10 |
| R205.200.R | 20 | 130 | 200 | 10 |
| R205.220.R | 22 | 140 | 210 | 13 |
| R205.240.R | 24 | 140 | 215 | 13 |
| R205.260.R | 26 | 140 | 215 | 13 |
| R205.280.R | 28 | 140 | 220 | 13 |
| R205.300.R | 30 | 140 | 220 | 13 |

R205.505.R 5 drills set \varnothing 4 -5 -6 -8 -10
R205.508.R 8 drills set \varnothing 3 -4 -5 -6 -7 -8 -9 -10

HW ADJUSTABLE COUNTERSINKS Z=2

ART. A199

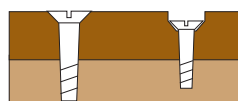
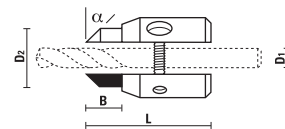

- Spare key supplied; single packed

| Item | D1 | D2 | α | B | L |
|-----------------------|------|-----------|----------|----|----|
| A199.030.R | 3/7 | 11/15 | 45° | 12 | 32 |
| A199.060.R NEW | 6/10 | 15,5/19,5 | 45° | 12 | 34 |

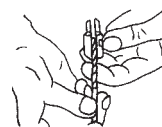

Insert the tool



Adjust the boring depth

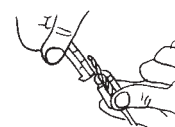

Line up the cutting edges of countersink and tool

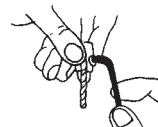

Tighten the screws



On request display free of charge by min order 10 pcs.

SP BRAD POINT DRILLS Z=2

ART. R206

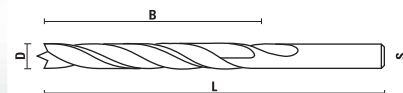

- 2-flutes
- For wall brackets, girders

| RH rotation | D | B | L | S |
|-------------|----|-----|-----|----|
| R206.080.R | 8 | 160 | 245 | 8 |
| R206.090.R | 9 | 160 | 245 | 9 |
| R206.100.R | 10 | 160 | 245 | 10 |
| R206.120.R | 12 | 160 | 245 | 10 |
| R206.121.R | 12 | 250 | 400 | 10 |
| R206.140.R | 14 | 160 | 245 | 10 |
| R206.141.R | 14 | 250 | 400 | 10 |
| R206.160.R | 16 | 160 | 245 | 10 |
| R206.161.R | 16 | 250 | 400 | 10 |
| R206.180.R | 18 | 160 | 245 | 10 |
| R206.181.R | 18 | 250 | 400 | 10 |
| R206.200.R | 20 | 160 | 245 | 10 |
| R206.201.R | 20 | 250 | 400 | 10 |

SP SINGLE FLUTE DRILLS "LEWIS" TYPE Z=1

ART. R207

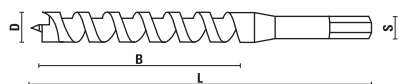

Hex shank



| RH rotation | D | B | L | S |
|-------------|----|-----|-----|----|
| R207.080.R | 8 | 220 | 300 | 8 |
| R207.100.R | 10 | 220 | 300 | 10 |
| R207.120.R | 12 | 220 | 300 | 10 |
| R207.140.R | 14 | 220 | 300 | 10 |
| R207.150.R | 15 | 220 | 300 | 10 |
| R207.160.R | 16 | 220 | 300 | 10 |
| R207.180.R | 18 | 220 | 300 | 13 |
| R207.200.R | 20 | 220 | 300 | 13 |
| R207.220.R | 22 | 220 | 300 | 13 |
| R207.240.R | 24 | 220 | 300 | 13 |
| R207.250.R | 25 | 220 | 300 | 13 |
| R207.260.R | 26 | 220 | 300 | 13 |
| R207.280.R | 28 | 220 | 300 | 13 |
| R207.300.R | 30 | 220 | 300 | 13 |

HS SPIRAL BITS Z=2

ART. R225

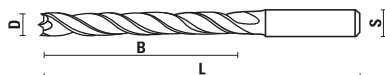

4-flutes

| RH rotation | D | B | L | S |
|-------------|----|-----|-----|-------|
| R225.060.R | 6 | 75 | 140 | 13x50 |
| R225.080.R | 8 | 85 | 150 | 13x50 |
| R225.100.R | 10 | 95 | 160 | 13x50 |
| R225.120.R | 12 | 105 | 170 | 13x50 |
| R225.130.R | 13 | 110 | 175 | 13x50 |
| R225.140.R | 14 | 115 | 180 | 13x50 |
| R225.160.R | 16 | 125 | 190 | 16x50 |
| R225.180.R | 18 | 130 | 200 | 16x50 |
| R225.200.R | 20 | 140 | 210 | 16x50 |
| R225.220.R | 22 | 150 | 220 | 16x50 |
| R225.240.R | 24 | 160 | 235 | 16x50 |
| R225.250.R | 25 | 170 | 250 | 20x50 |
| R225.300.R | 30 | 190 | 270 | 20x50 |

HS SPIRAL BITS Z=2

ART. R226

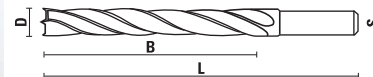

4-flutes

| RH rotation | D | B | L | S |
|-------------|----|-----|-----|-------|
| R226.110.R | 11 | 100 | 140 | 10x30 |
| R226.120.R | 12 | 100 | 140 | 10x30 |
| R226.130.R | 13 | 100 | 140 | 10x30 |
| R226.140.R | 14 | 100 | 140 | 10x30 |
| R226.150.R | 15 | 100 | 140 | 10x30 |
| R226.160.R | 16 | 100 | 140 | 10x30 |
| R226.180.R | 18 | 100 | 140 | 10x30 |
| R226.200.R | 20 | 100 | 140 | 10x30 |

HS STEP DRILLS Z=2

ART. R202

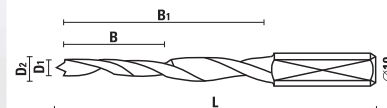

- S=∅10 flat on the shank
- For Masterwood machines

| RH rotation | D1 | D2 | B | B1 | L | Anuba |
|-------------|-----|-----|----|----|-----|-------|
| R202.090.R | 3,8 | 5 | 20 | 40 | 75 | 9 |
| R202.110.R | 4,2 | 5,7 | 20 | 45 | 80 | 11 |
| R202.130.R | 5,2 | 6,5 | 15 | 50 | 85 | 13 |
| R202.140.R | 5,5 | 7 | 15 | 55 | 90 | 14 |
| R202.160.R | 6 | 7,7 | 15 | 60 | 95 | 16 |
| R202.180.R | 6,6 | 8,2 | 20 | 70 | 105 | 18 |
| R202.200.R | 7,2 | 8,7 | 20 | 80 | 115 | 20 |



HS STEP DRILLS Z=2

ART. R203

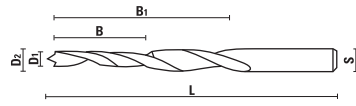

Shank throughout cylindrical

| RH rotation | D1 | D2 | B | B1 | L | S | Anuba |
|-------------|------|------|----|----|-----|------|-------|
| R203.130.R | 5,4 | 6,5 | 20 | 50 | 80 | 6,5 | 13 |
| R203.131.R | 5,7 | 6,75 | 20 | 65 | 105 | 6,75 | 13 |
| R203.140.R | 6 | 7 | 20 | 50 | 80 | 7 | 14 |
| R203.141.R | 6,25 | 7,25 | 25 | 60 | 90 | 7,25 | 14 |
| R203.142.R | 6,25 | 7,25 | 20 | 65 | 105 | 7,25 | 14 |
| R203.160.R | 6,5 | 7,75 | 25 | 60 | 90 | 7,75 | 16 |
| R203.161.R | 6,5 | 7,75 | 20 | 70 | 110 | 7,75 | 16 |
| R203.180.R | 6,7 | 8,5 | 25 | 60 | 90 | 8,5 | 18 |
| R203.181.R | 6,7 | 8,5 | 25 | 70 | 110 | 8,5 | 18 |

HW/HS 3-DIAMETER BITS "CONFIRMAT" Z=2

ART. R104 - R204

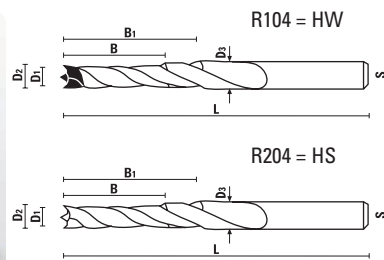

- For "Confirmat" joints
- R104 = HW
- R204 = HS

| RH rotation | D1 | D2 | D3 | B | B1 | L | Mat. | S |
|-------------|-----|-----|----|----|----|-----|------|-------|
| R104.100.R | 5,5 | 7,3 | 10 | 35 | 56 | 138 | HW | 10x50 |
| R204.100.R | 5,5 | 7,3 | 10 | 35 | 56 | 138 | HS | 10x50 |
| R204.101.R | 5,5 | 7,3 | 10 | 40 | 60 | 120 | HS | 10x40 |

HW/HS 3-DIAMETER DRILLS, ADJUSTABLE Z=2

ART. R108 - R209

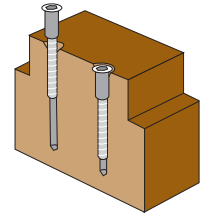
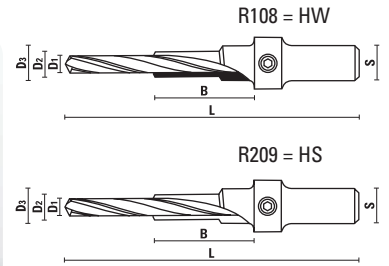

- 3 Steps drill bits
- For mounting joints screws
- HS spare drills
- For mounting connecting screws "Confirmat", "Directa" etc..

| RH rotation | D1 | D2 | D3 | B | L | Mat. | S |
|-----------------------|-----|-----|------|----|-----|------|----|
| R108.050.R | 5 | 8,5 | 11,5 | 25 | 100 | HW | 10 |
| R209.035.R NEW | 3,5 | 5 | 8 | 25 | 100 | HS | 10 |
| R209.044.R NEW | 4,4 | 6,5 | 9,5 | 20 | 95 | HS | 10 |
| R209.050.R NEW | 5 | 7 | 10 | 29 | 100 | HS | 10 |

| Spare drill bit | D |
|-----------------------|-----|
| R108.051.R | 5 |
| R209.036.R NEW | 3,5 |
| R209.045.R NEW | 4,4 |
| R209.051.R NEW | 5 |

HS TWIST DRILLS Z=2

ART. R208

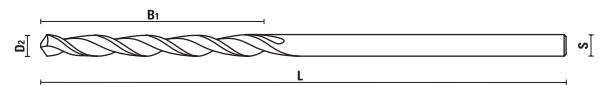

Anuba 9÷11 No step drills

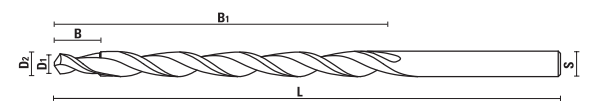

Anuba 13÷22 Step drills

For Anuba SFS INTECK

| RH rotation | D1 | D2 | B1 | B | L | S | Anuba |
|-------------|-----|------|----|----|-----|------|-------|
| R208.090.R | | 5,2 | 52 | | 132 | 5,2 | 9 |
| R208.110.R | | 5,7 | 57 | | 139 | 5,7 | 11 |
| R208.130.R | 5,3 | 6,7 | 63 | 12 | 148 | 6,7 | 13 |
| R208.140.R | 5,8 | 7,2 | 69 | 13 | 156 | 7,2 | 14 |
| R208.160.R | 6,3 | 7,7 | 75 | 14 | 165 | 7,7 | 16 |
| R208.180.R | 7,2 | 8,6 | 81 | 14 | 175 | 8,6 | 18 |
| R208.200.R | 7,4 | 8,8 | 81 | 16 | 175 | 8,8 | 20 |
| R208.220.R | 8,8 | 10,2 | 87 | 23 | 184 | 10,2 | 22 |

HW ADJUSTABLE DIAMETER BORING BITS 30/60 MM

ART. R110

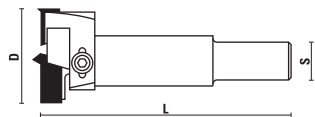

Complete with 1 knife \varnothing 30÷45 mm + 1 knife \varnothing 45÷60 + key

| RH rotation | D | L | S |
|-------------|-------|----|-------|
| R110.600.R | 30÷60 | 90 | 10x30 |

Spare knife

| | |
|------------|-------|
| R110.300.R | 30÷45 |
| R110.450.R | 45÷60 |



Z051.012.R

HW ADJUSTABLE DIAMETER BORING BITS 60/80 MM

ART. R110

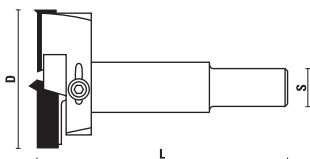

Complete with 1 knife \varnothing 60÷80 + key

| RH rotation | D | L | S |
|-------------|-------|-----|-------|
| R110.800.R | 60÷80 | 100 | 12x40 |

Spare knife

| | |
|------------|-------|
| R110.801.R | 60÷80 |
|------------|-------|



Z051.013.R



HW HINGE BORING BITS Z=2+2

ART. R111



For soft and hard wood, plywood and laminated chipboard



| RH rotation | D | L | S |
|-------------|----|-----|--------|
| R111.140.R | 14 | 90 | 10x60 |
| R111.141.R | 14 | 120 | 10x100 |
| R111.150.R | 15 | 90 | 10x60 |
| R111.151.R | 15 | 120 | 10x100 |
| R111.160.R | 16 | 90 | 10x60 |
| R111.161.R | 16 | 120 | 10x100 |
| R111.170.R | 17 | 90 | 10x60 |
| R111.180.R | 18 | 90 | 10x60 |
| R111.181.R | 18 | 120 | 10x100 |
| R111.190.R | 19 | 90 | 10x60 |
| R111.200.R | 20 | 90 | 10x60 |
| R111.201.R | 20 | 120 | 10x100 |
| R111.210.R | 21 | 90 | 10x60 |
| R111.220.R | 22 | 90 | 10x60 |
| R111.221.R | 22 | 120 | 10x100 |
| R111.230.R | 23 | 90 | 10x60 |
| R111.240.R | 24 | 90 | 10x60 |
| R111.250.R | 25 | 90 | 10x60 |
| R111.251.R | 25 | 120 | 10x100 |
| R111.260.R | 26 | 90 | 10x60 |
| R111.261.R | 26 | 120 | 10x100 |
| R111.270.R | 27 | 90 | 10x60 |
| R111.280.R | 28 | 90 | 10x60 |
| R111.300.R | 30 | 90 | 10x60 |
| R111.301.R | 30 | 120 | 10x100 |
| R111.320.R | 32 | 90 | 10x60 |
| R111.340.R | 34 | 90 | 10x60 |
| R111.350.R | 35 | 90 | 10x60 |
| R111.351.R | 35 | 120 | 10x100 |
| R111.360.R | 36 | 90 | 10x60 |
| R111.380.R | 38 | 90 | 10x60 |
| R111.400.R | 40 | 90 | 10x60 |
| R111.401.R | 40 | 120 | 10x100 |
| R111.420.R | 42 | 90 | 10x60 |
| R111.450.R | 45 | 90 | 10x60 |
| R111.480.R | 48 | 90 | 10x60 |
| R111.500.R | 50 | 90 | 10x60 |
| R111.550.R | 55 | 90 | 10x60 |
| R111.600.R | 60 | 90 | 10x60 |

R111.905.R 5 drills set \varnothing 15 -20 -25 -30 -35



HW HINGE BORING BITS Z=2+2

ART. R112

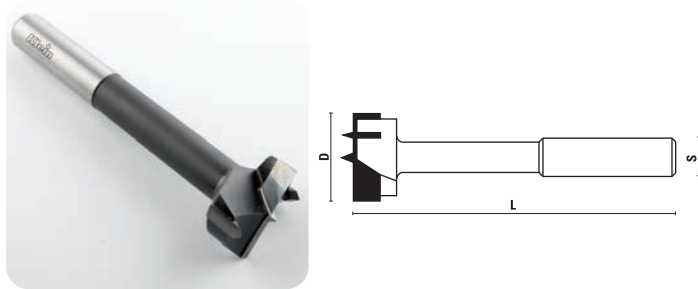

For soft and hard wood, plywood and laminated chipboard

| RH rotation | D | L | S |
|-------------|----|-----|-------|
| R112.150.R | 15 | 120 | 13x50 |
| R112.160.R | 16 | 120 | 13x50 |
| R112.200.R | 20 | 120 | 13x50 |
| R112.220.R | 22 | 130 | 13x50 |
| R112.240.R | 24 | 130 | 13x50 |
| R112.250.R | 25 | 130 | 13x50 |
| R112.260.R | 26 | 130 | 13x50 |
| R112.280.R | 28 | 130 | 13x50 |
| R112.300.R | 30 | 130 | 13x50 |
| R112.320.R | 32 | 130 | 16x50 |
| R112.350.R | 35 | 130 | 16x50 |
| R112.400.R | 40 | 130 | 16x50 |
| R112.450.R | 45 | 130 | 16x50 |
| R112.500.R | 50 | 130 | 16x50 |
| R112.550.R | 55 | 140 | 16x50 |
| R112.600.R | 60 | 140 | 16x50 |
| R112.650.R | 65 | 140 | 16x50 |
| R112.700.R | 70 | 140 | 16x50 |
| R112.800.R | 80 | 140 | 20x50 |
| R112.900.R | 90 | 140 | 20x50 |

T.C.T. HINGE BORING BITS Z=2+2 (art. R111-R112)

How to determine the feeding speed according to the machine (RPM):

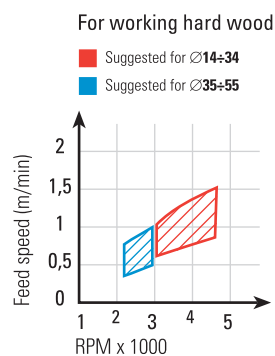

HW INTERCHANGEABLE HINGE BORING BITS Z=2+2

ART. R130

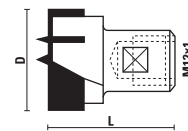

Use with Art. Z021 page 10.04, 10.05

| RH rotation | LH rotation | D | L |
|-------------|-------------|----|----|
| R130.200.R | R130.200.L | 20 | 30 |
| R130.250.R | R130.250.L | 25 | 30 |
| R130.260.R | R130.260.L | 26 | 30 |
| R130.280.R | R130.280.L | 28 | 30 |
| R130.300.R | R130.300.L | 30 | 30 |
| R130.320.R | R130.320.L | 32 | 30 |
| R130.340.R | R130.340.L | 34 | 30 |
| R130.350.R | R130.350.L | 35 | 30 |
| R130.360.R | R130.360.L | 36 | 30 |
| R130.380.R | R130.380.L | 38 | 30 |
| R130.400.R | R130.400.L | 40 | 30 |
| R130.450.R | | 45 | 30 |
| R130.480.R | | 48 | 30 |
| R130.500.R | | 50 | 30 |
| R130.550.R | | 55 | 30 |
| R130.600.R | | 60 | 30 |
| R130.650.R | | 65 | 30 |
| R130.700.R | | 70 | 30 |

Art. Z021 see section Spare parts page 10.04, 10.05

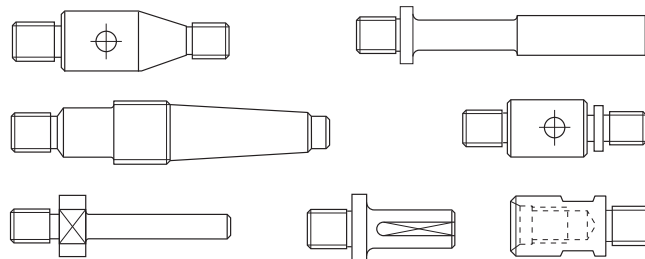

visit our website

www.sistemiklein.com



SP "FORSTNER" BITS Z=2+2

ART. R213

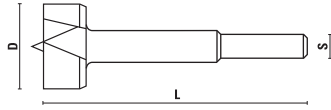

For soft and hard wood

| RH rotation | D | L | S |
|-------------|----|----|-------|
| R213.100.R | 10 | 90 | 8x30 |
| R213.120.R | 12 | 90 | 8x30 |
| R213.140.R | 14 | 90 | 8x30 |
| R213.150.R | 15 | 90 | 8x30 |
| R213.160.R | 16 | 90 | 8x30 |
| R213.180.R | 18 | 90 | 8x30 |
| R213.200.R | 20 | 90 | 8x30 |
| R213.220.R | 22 | 90 | 8x30 |
| R213.240.R | 24 | 90 | 8x30 |
| R213.250.R | 25 | 90 | 8x30 |
| R213.260.R | 26 | 90 | 8x30 |
| R213.280.R | 28 | 90 | 8x30 |
| R213.300.R | 30 | 90 | 8x30 |
| R213.320.R | 32 | 90 | 10x30 |
| R213.340.R | 34 | 90 | 10x30 |
| R213.350.R | 35 | 90 | 10x30 |
| R213.360.R | 36 | 90 | 10x30 |
| R213.380.R | 38 | 90 | 10x30 |
| R213.400.R | 40 | 90 | 10x30 |
| R213.450.R | 45 | 90 | 10x30 |
| R213.500.R | 50 | 90 | 10x30 |

R213.905.R 5 boring bits set Ø 15 - 20 - 25 - 30 - 35

R213.915.R 15 boring bits set Ø 10 - 12 - 15 - 16 - 18 - 20 - 22 - 25 - 26 - 28 - 30 - 35 - 40 - 45 - 50



R213.905.R



R213.915.R

SP PLUG CUTTERS

ART. R220

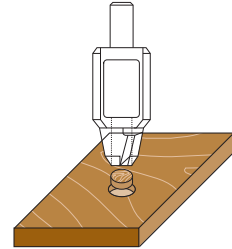
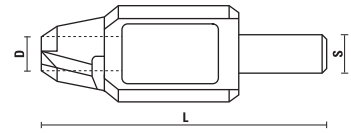

For soft and hard wood

| RH rotation | D | L | S | Z |
|-------------|----|-----|-------|---|
| R220.080.R | 8 | 140 | 13x50 | 4 |
| R220.100.R | 10 | 140 | 13x50 | 4 |
| R220.120.R | 12 | 140 | 13x50 | 4 |
| R220.150.R | 15 | 140 | 13x50 | 4 |
| R220.200.R | 20 | 140 | 13x50 | 4 |
| R220.250.R | 25 | 140 | 13x50 | 5 |
| R220.300.R | 30 | 140 | 13x50 | 5 |
| R220.350.R | 35 | 140 | 16x50 | 6 |
| R220.400.R | 40 | 140 | 16x50 | 6 |

HW/HS COUNTERSINKS Z=2

ART. R150 - R250

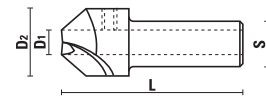

| RH rotation | LH rotation | D1 | D2 | L | S | Mat. |
|-------------|-------------|----|----|----|-------|------|
| R150.030.R | R150.030.L | 3 | 15 | 40 | 10x25 | HW |
| R150.040.R | R150.040.L | 4 | 15 | 40 | 10x25 | HW |
| R150.050.R | R150.050.L | 5 | 15 | 40 | 10x25 | HW |
| R150.060.R | R150.060.L | 6 | 15 | 40 | 10x25 | HW |

| | | | | | | |
|------------|------------|---|----|----|-------|----|
| R250.030.R | R250.030.L | 3 | 15 | 40 | 10x25 | HS |
| R250.040.R | R250.040.L | 4 | 15 | 40 | 10x25 | HS |
| R250.050.R | R250.050.L | 5 | 15 | 40 | 10x25 | HS |
| R250.060.R | R250.060.L | 6 | 15 | 40 | 10x25 | HS |

ADJUSTABLE COUNTERSINK SET

Thanks to our new solution, it is now possible to adjust drilling depth and make seats for flush screws in an easy and quick manner, simply by using a power portable drill. You can find below the directions of use for the two different solutions both with cylindrical and hex shank. It is very important to drill a pilot hole before inserting the screw, in order to obtain excellent results, both aesthetic and long-lasting performance.

HOW TO USE WITH CYLINDRICAL SHANK



HOW TO USE WITH HEX SHANK

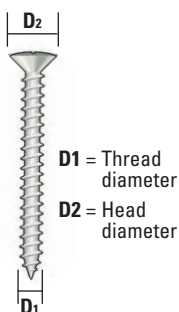

Pilot hole dimensions will be changed based on the type of wood to drill. For drilling soft wood, consider a smaller hole - roughly 10% - compared to hard wood

| D2 | D1 | Soft wood | Hard wood |
|-----|-----|-----------------|-----------------|
| 7 | 3,5 | ∅ drill bit 2,4 | ∅ drill bit 2,8 |
| 8 | 4 | ∅ drill bit 2,8 | ∅ drill bit 3,2 |
| 8,9 | 4,5 | ∅ drill bit 3,2 | ∅ drill bit 3,5 |
| 9,6 | 5 | ∅ drill bit 3,5 | ∅ drill bit 4 |

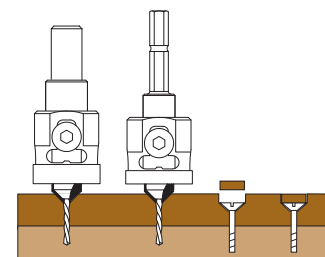

HW COUNTERSINKS 45° Z=2 WITH SHANK S=8

ART. R155



| RH rotation | D1 | D2 | L | S |
|-----------------------|-----|----|----|---|
| R155.030.R NEW | 3 | 10 | 44 | 8 |
| R155.035.R NEW | 3,5 | 10 | 44 | 8 |
| R155.040.R NEW | 4 | 10 | 44 | 8 |
| R155.050.R NEW | 5 | 10 | 44 | 8 |



Z051.324.R



Z052.006.N

ADJUSTABLE DEPTH STOPPER

ART. Z003

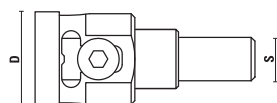

- Depth stopper made in metal alloy **with ball bearing inside for no-friction operations**
- Great chip evacuation thanks to two lateral openings.
- Easy adjustment of countersink and drilling depth.
- Complete with adjusting screw.

| Item | D | S |
|-----------------------|----|-----|
| Z003.900.N NEW | 32 | 9,5 |



Z051.214.R



Z052.055.N

ADJUSTABLE COUNTERSINK SET

ART. R156

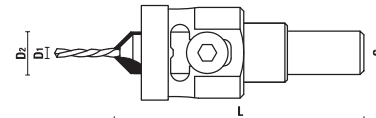

- Sold complete with HS drill bit (art R210)
- Depth stopper made in metal alloy **with ball bearing inside for no-friction operations**
- Great chip evacuation thanks to two lateral openings
- No risk of markings and scratches
- Easy adjustment of countersink and drilling depth
- Complete with adjusting screw

| RH rotation | D1 | D2 | L | S |
|-----------------------|-----|----|----|-----|
| R156.030.R NEW | 3 | 10 | 73 | 9,5 |
| R156.035.R NEW | 3,5 | 10 | 73 | 9,5 |
| R156.040.R NEW | 4 | 10 | 73 | 9,5 |
| R156.050.R NEW | 5 | 10 | 73 | 9,5 |



Z051.214.R



Z051.324.R



Z052.055.N

HW COUNTERSINKS 45° Z=2 WITH HEX SHANK

ART. R158

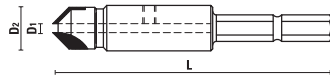

Quick change 1/4" (6,35mm) hex shank

| RH rotation | D1 | D2 | L |
|-----------------------|-----|------|----|
| R158.024.R NEW | 2,4 | 9,5 | 60 |
| R158.028.R NEW | 2,8 | 9,5 | 60 |
| R158.030.R NEW | 3 | 9,5 | 60 |
| R158.032.R NEW | 3,2 | 9,5 | 60 |
| R158.040.R NEW | 4 | 9,5 | 60 |
| R158.050.R NEW | 5 | 12,7 | 70 |
| R158.060.R NEW | 6 | 12,7 | 70 |



Z051.324.R



Z052.006.N

ADJUSTABLE DEPTH STOPPER

ART. Z003

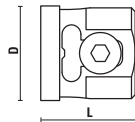

- With a **special collar made in Delrin for low friction operation and easy depth adjustment**
- Large side openings for chip clearance

| Item | D | L |
|-----------------------|----|----|
| Z003.905.N NEW | 25 | 25 |

ADJUSTABLE COUNTERSINK SET

ART. R159

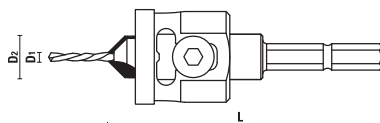

- Sold complete with HS drill bit (art R210)
- With a **special collar made in Delrin for low friction operation and easy depth adjustment**
- Quick change 1/4" (6,35mm) hex shank
- Large side openings for chip clearance

| RH rotation | D1 | D2 | L |
|-----------------------|-----|------|----|
| R159.024.R NEW | 2,4 | 9,5 | 60 |
| R159.028.R NEW | 2,8 | 9,5 | 60 |
| R159.030.R NEW | 3 | 9,5 | 60 |
| R159.032.R NEW | 3,2 | 9,5 | 60 |
| R159.040.R NEW | 4 | 9,5 | 60 |
| R159.050.R NEW | 5 | 12,7 | 70 |
| R159.060.R NEW | 6 | 12,7 | 70 |



Z051.214.R



Z051.324.R



Z052.055.N

HS PLUG CUTTERS Z=1

ART. R221

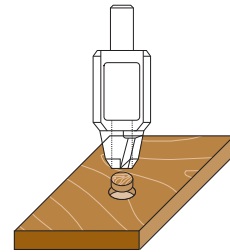
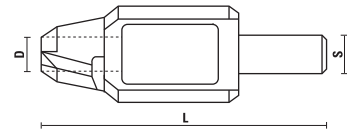

| RH rotation | D | L | S | Z |
|-----------------------|------|----|---|---|
| R221.095.R NEW | 9,5 | 61 | 8 | 1 |
| R221.100.R NEW | 10 | 61 | 8 | 1 |
| R221.127.R NEW | 12,7 | 61 | 8 | 1 |

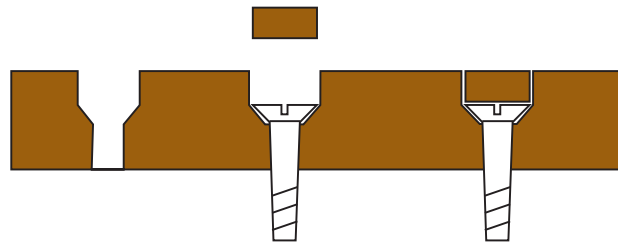

After having used our adjustable countersink set (R156/R159), use our plug cutters (art R221) to obtain the plug to create a perfect and smooth surface.

HS SPIRAL BITS Z=2

ART. R210 - R215 - R216

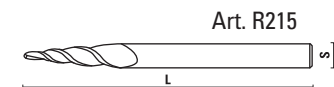

| Item | D1 | D | L | S |
|-----------------------|----|-----|----|-----|
| R210.024.R NEW | | 2,4 | 57 | 2,4 |
| R210.030.R NEW | | 3 | 61 | 3 |
| R210.032.R NEW | | 3,2 | 65 | 3,2 |
| R210.035.R NEW | | 3,5 | 70 | 3,5 |
| R210.040.R NEW | | 4 | 75 | 4 |
| R210.050.R NEW | | 5 | 86 | 5 |
| R210.060.R NEW | | 6 | 93 | 6 |
| R215.024.R NEW | | 2,4 | 57 | 2,4 |
| R215.032.R NEW | | 3,2 | 70 | 3,2 |
| R215.040.R NEW | | 4 | 80 | 4 |
| R215.050.R NEW | | 5 | 89 | 5 |
| R215.060.R NEW | | 6 | 98 | 6 |

| | | | | |
|-----------------------|-----|---|----|---|
| R216.040.R NEW | 2,8 | 4 | 75 | 4 |
| R216.050.R NEW | 3,5 | 5 | 86 | 5 |

Art R210 Standard spiral drill bit for full thread screw



Art R215 Tapered drill bit for full thread screw and greater holding power



Art R216 Two steps drill bit for partial thread screw



HW/HS DOVETAIL BITS 9° - Z=1

ART. R151 - R251

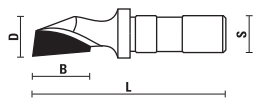

For OMEC machines

| RH rotation | D | B | L | S | Z | Mat. |
|-------------|----|----|----|-------|---|------|
| R151.140.R | 14 | 18 | 60 | 12x30 | 1 | HW |
| R251.140.R* | 14 | 18 | 60 | 12x30 | 1 | HS |

* Selling out

VHW DOVETAIL BITS Z=2

ART. R152

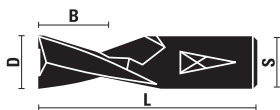

- For OMEC machines
- Solid carbide

| RH rotation | D | B | L |
|-------------|----|----|----|
| R152.140.R | 14 | 16 | 60 |

HW/HS DOVETAIL BITS Z=2

ART. R160 - R260



| RH rotation | D | B | S | Mat. |
|-------------|----|----|-------|------|
| R160.120.R | 12 | 13 | 10x40 | HW |
| R160.140.R | 14 | 15 | 10x40 | HW |
| R160.150.R | 15 | 16 | 10x40 | HW |
| R160.160.R | 16 | 17 | 10x40 | HW |
| R160.180.R | 18 | 20 | 10x40 | HW |
| R260.120.R | 12 | 13 | 10x40 | HS |
| R260.140.R | 14 | 15 | 10x40 | HS |
| R260.150.R | 15 | 16 | 10x40 | HS |
| R260.160.R | 16 | 17 | 10x40 | HS |
| R260.180.R | 18 | 20 | 10x40 | HS |

- Add. charge for threaded shank
- Add. charge for inside threaded shank

SP SLOT MORTISING BITS WITH CHIPBREAKER Z=2

ART. S201- S202

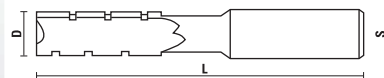

Chipbreaker execution



| RH rotation | LH rotation | D | L | S | |
|-------------|-------------|----|-----|-------|----------------|
| S201.060.R | S201.060.L | 6 | 105 | 13x50 | |
| S201.061.R | S201.061.L | 6 | 120 | 13x50 | Long execution |
| S201.070.R | S201.070.L | 7 | 110 | 13x50 | |
| S201.080.R | S201.080.L | 8 | 115 | 13x50 | |
| S201.081.R | S201.081.L | 8 | 130 | 13x50 | Long execution |
| S201.090.R | S201.090.L | 9 | 120 | 13x50 | |
| S201.100.R | S201.100.L | 10 | 125 | 13x50 | |
| S201.101.R | S201.101.L | 10 | 140 | 13x50 | Long execution |
| S201.110.R | S201.110.L | 11 | 130 | 13x50 | |
| S201.120.R | S201.120.L | 12 | 135 | 13x50 | |
| S201.121.R | S201.121.L | 12 | 150 | 13x50 | Long execution |
| S201.130.R | S201.130.L | 13 | 140 | 13x50 | |
| S201.140.R | S201.140.L | 14 | 145 | 13x50 | |
| S201.141.R | S201.141.L | 14 | 160 | 13x50 | Long execution |
| S201.150.R | S201.150.L | 15 | 150 | 13x50 | |
| S201.160.R | S201.160.L | 16 | 155 | 13x50 | |

| | | | | | |
|------------|------------|----|-----|-------|----------------|
| S202.060.R | S202.060.L | 6 | 105 | 16x50 | |
| S202.061.R | S202.061.L | 6 | 120 | 16x50 | Long execution |
| S202.070.R | S202.070.L | 7 | 110 | 16x50 | |
| S202.080.R | S202.080.L | 8 | 115 | 16x50 | |
| S202.081.R | S202.081.L | 8 | 130 | 16x50 | Long execution |
| S202.090.R | S202.090.L | 9 | 120 | 16x50 | |
| S202.100.R | S202.100.L | 10 | 125 | 16x50 | |
| S202.101.R | S202.101.L | 10 | 140 | 16x50 | Long execution |
| S202.110.R | S202.110.L | 11 | 130 | 16x50 | |
| S202.120.R | S202.120.L | 12 | 135 | 16x50 | |
| S202.121.R | S202.121.L | 12 | 150 | 16x50 | Long execution |
| S202.130.R | S202.130.L | 13 | 140 | 16x50 | |
| S202.140.R | S202.140.L | 14 | 145 | 16x50 | |
| S202.141.R | S202.141.L | 14 | 160 | 16x50 | Long execution |
| S202.150.R | S202.150.L | 15 | 150 | 16x50 | |
| S202.160.R | S202.160.L | 16 | 155 | 16x50 | |
| S202.161.R | S202.161.L | 16 | 170 | 16x50 | Long execution |
| S202.180.R | S202.180.L | 18 | 165 | 16x50 | |
| S202.181.R | S202.181.L | 18 | 180 | 16x50 | Long execution |
| S202.200.R | S202.200.L | 20 | 175 | 16x50 | |
| S202.220.R | S202.220.L | 22 | 180 | 16x50 | |
| S202.240.R | S202.240.L | 24 | 180 | 16x50 | |

X100.006.R 6 mortising bits set Ø 6 - 8 - 10 - 12 - 14 - 16 Rh rotation
X100.006.L 6 mortising bits set Ø 6 - 8 - 10 - 12 - 14 - 16 Lh rotation

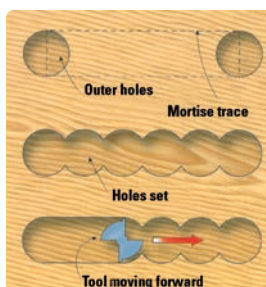

HL RECIPROCATING SLOT MORTISING BITS

ART. S210 - S211 - S212 - S213

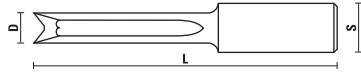

| Item | D | L | S | Z |
|------------|----|-----|-------|---|
| S210.060.N | 6 | 100 | 16x50 | 2 |
| S210.070.N | 7 | 100 | 16x50 | 2 |
| S210.080.N | 8 | 100 | 16x50 | 2 |
| S210.090.N | 9 | 100 | 16x50 | 2 |
| S210.100.N | 10 | 110 | 16x50 | 2 |
| S210.120.N | 12 | 110 | 16x50 | 2 |
| S210.140.N | 14 | 110 | 16x50 | 2 |
| S210.160.N | 16 | 110 | 16x50 | 2 |
| S211.060.N | 6 | 100 | 13x50 | 4 |
| S211.070.N | 7 | 100 | 13x50 | 4 |
| S211.080.N | 8 | 100 | 13x50 | 4 |
| S211.090.N | 9 | 100 | 13x50 | 4 |
| S211.100.N | 10 | 110 | 13x50 | 4 |
| S211.120.N | 12 | 110 | 13x50 | 4 |
| S211.140.N | 14 | 110 | 13x50 | 4 |
| S211.160.N | 16 | 110 | 13x50 | 4 |
| S212.060.N | 6 | 60 | 12x30 | 2 |
| S212.070.N | 7 | 60 | 12x30 | 2 |
| S212.080.N | 8 | 60 | 12x30 | 2 |
| S212.100.N | 10 | 60 | 12x30 | 4 |
| S212.120.N | 12 | 60 | 12x30 | 4 |
| S213.060.N | 6 | 73 | 10x40 | 4 |
| S213.070.N | 7 | 73 | 10x40 | 4 |
| S213.080.N | 8 | 73 | 10x40 | 4 |
| S213.100.N | 10 | 73 | 10x40 | 4 |
| S213.120.N | 12 | 73 | 10x40 | 4 |

HL RECIPROCATING SLOT MORTISING BITS Z=3

ART. S214

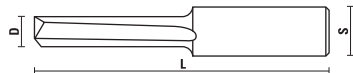

| RH rotation | LH rotation | D | L | S | Z |
|-------------|-------------|----|-----|-------|---|
| S214.060.R | S214.060.L | 6 | 110 | 16x50 | 3 |
| S214.080.R | S214.080.L | 8 | 110 | 16x50 | 3 |
| S214.100.R | S214.100.L | 10 | 110 | 16x50 | 3 |
| S214.120.R | S214.120.L | 12 | 110 | 16x50 | 3 |
| S214.140.R | S214.140.L | 14 | 115 | 16x50 | 3 |
| S214.160.R | S214.160.L | 16 | 115 | 16x50 | 3 |
| S214.180.R | S214.180.L | 18 | 115 | 16x50 | 3 |
| S214.200.R | S214.200.L | 20 | 115 | 16x50 | 3 |

HW RECIPROCATING SLOT MORTISING BITS

ART. S110 - S111

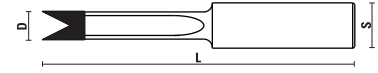

| Item | D | L | S | Z |
|------------|----|-----|-------|---|
| S110.060.N | 6 | 100 | 16x50 | 2 |
| S110.080.N | 8 | 100 | 16x50 | 2 |
| S110.100.N | 10 | 110 | 16x50 | 2 |
| S110.120.N | 12 | 110 | 16x50 | 2 |
| S110.140.N | 14 | 110 | 16x50 | 2 |
| S110.160.N | 16 | 110 | 16x50 | 2 |
| S111.060.N | 6 | 100 | 13x50 | 2 |
| S111.080.N | 8 | 100 | 13x50 | 2 |
| S111.100.N | 10 | 110 | 13x50 | 2 |
| S111.120.N | 12 | 110 | 13x50 | 2 |
| S111.140.N | 14 | 110 | 13x50 | 2 |
| S111.160.N | 16 | 110 | 13x50 | 2 |

HW/SP GROOVING CUTTERS Z=2

ART. S120 - S220

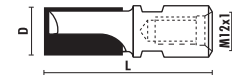

For the lock housing

| RH rotation | D | L | Mat. |
|-------------|----|----|------|
| S120.200.R | 20 | 60 | HM |
| S120.220.R | 22 | 60 | HM |
| S220.200.R | 20 | 60 | SP |
| S220.220.R | 22 | 60 | SP |

HW/SP SLOT MORTISING CUTTERS Z=2

ART. S121 - S221

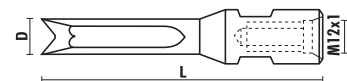

For cutting slots

| RH rotation | D | L | Mat. |
|-------------|----|-----|------|
| S121.120.R | 12 | 100 | HW |
| S121.140.R | 14 | 100 | HW |
| S221.120.R | 12 | 100 | SP |
| S221.140.R | 14 | 100 | SP |

HW/SP BORING BITS Z=2

ART. S122 - S222

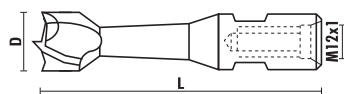

For boring

| RH rotation | D | L | Mat. |
|-------------|----|-----|------|
| S122.180.R | 18 | 100 | HW |
| S122.200.R | 20 | 100 | HW |
| S222.180.R | 18 | 100 | SP |
| S222.200.R | 20 | 100 | SP |

HW/SP SLOT BORING BITS Z=2

ART. S123 - S223

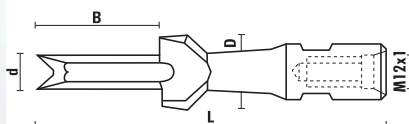

To produce slots and holes

| RH rotation | d | D | B | L | Mat. |
|-------------|----|----|----|-----|------|
| S123.110.R | 11 | 19 | 62 | 155 | HW |
| S123.120.R | 12 | 19 | 62 | 155 | HW |
| S223.110.R | 11 | 19 | 62 | 155 | SP |
| S223.120.R | 12 | 19 | 62 | 155 | SP |

HS DOWEL CUTTERS

ART. S250

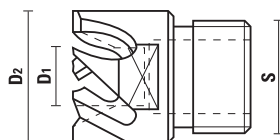

| RH rotation | D1 | D2 | Z | S |
|-------------|------|----|---|----------|
| S250.080.R | 8 | 25 | 4 | 21/14x1" |
| S250.082.R | 8,2 | 25 | 4 | 21/14x1" |
| S250.100.R | 10 | 25 | 4 | 21/14x1" |
| S250.102.R | 10,2 | 25 | 4 | 21/14x1" |
| S250.120.R | 12 | 25 | 4 | 21/14x1" |
| S250.122.R | 12,2 | 25 | 4 | 21/14x1" |
| S250.162.R | 16,2 | 32 | 5 | 26/14x1" |

HS CUTTERS FOR COPYING LATHES

ART. S260

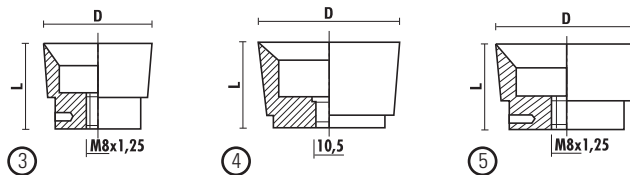
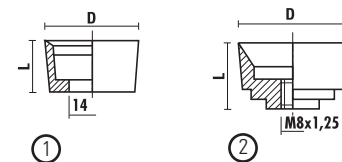

| Item | Drawing | D | L |
|------------|---------|----|----|
| S260.320.N | 1 | 32 | 15 |
| S260.350.N | 2 | 35 | 20 |
| S260.360.N | 3 | 36 | 26 |
| S260.400.N | 4 | 40 | 25 |
| S260.450.N | 5 | 45 | 26 |

HS CUTTERS FOR COPYING LATHES

ART. S270

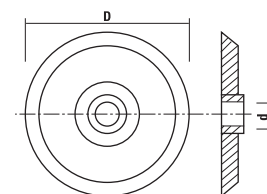

| Item | D | d |
|------------|----|------|
| S270.750.N | 75 | 10,3 |

HW HOLE SAWS

ART. S180

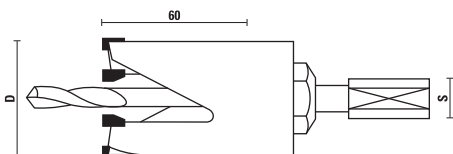

- For large boring depth, **suitable for wood, chipboard, plastic materials, glass fibers ecc.**
- Bore depth 60 mm
- Right hand rotation
- Single packed
- With HS centering drill included

| Item | D | S | Z | RPM |
|---------------|-----|----|---|-------|
| S180.220.R | 22 | 10 | 2 | 2.800 |
| S180.250.R | 25 | 10 | 2 | 2.800 |
| S180.270.R | 27 | 10 | 2 | 2.800 |
| S180.300.R | 30 | 10 | 2 | 2.300 |
| S180.320.R | 32 | 12 | 2 | 2.300 |
| S180.350.R | 35 | 12 | 3 | 2.300 |
| S180.380.R | 38 | 12 | 3 | 2.300 |
| S180.400.R | 40 | 12 | 3 | 1.800 |
| S180.450.R | 45 | 12 | 3 | 1.800 |
| S180.480.R | 48 | 12 | 3 | 1.800 |
| S180.500.R | 50 | 12 | 3 | 1.800 |
| S180.550.R | 55 | 12 | 4 | 1.500 |
| S180.600.R | 60 | 12 | 4 | 1.500 |
| S180.650.R | 65 | 12 | 4 | 1.200 |
| S180.680.R | 68 | 12 | 4 | 1.200 |
| S180.700.R | 70 | 12 | 4 | 1.200 |
| S180.750.R | 75 | 12 | 5 | 1.000 |
| S180.800.R | 80 | 12 | 5 | 1.000 |
| S180.850.R | 85 | 12 | 5 | 1.000 |
| S180.900.R | 90 | 12 | 5 | 1.000 |
| S180.999.R | 100 | 12 | 5 | 700 |
| S180.999.R127 | 127 | 12 | 5 | 500 |

11 pcs. display

S180.011.N (Ø22, Ø25, Ø27, Ø30, Ø35, Ø38, Ø40, Ø45, Ø50, Ø55, Ø60)



S180.011.N

Spare parts

Arbor

| | |
|------------|------|
| S181.100.R | S=10 |
| S181.120.R | S=12 |

HS centering drill

S182.063.R D=6,3 L=100

17 pcs. display

S180.017.N (Ø22, Ø25, Ø27, Ø30, Ø35, Ø38, Ø40, Ø45, Ø50, Ø55, Ø60, Ø65, Ø68, Ø70, Ø80, Ø90, Ø100)



S180.017.N

Application table

| WOOD | | |
|------|-----------|------------|
| Hard | Chipboard | Composites |
| XXX | XXX | XXX |

| PLASTIC | | | |
|------------|---------|-----|--------|
| Fiberglass | Acrylic | PVC | Rubber |
| XXX | XX | XX | XX |

Router bits and chucks for CNC routers



7



HW ROUTER BITS Z=2
Page 7.09



VHW ROUTER BITS Z=2
Page 7.09

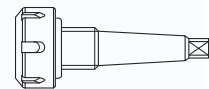

CONCENTRIC CHUCKS S=MK2
Page 7.09

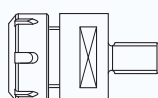

CONCENTRIC CHUCKS
Page 7.09

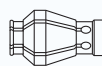

SPRING COLLETS
Page 7.09

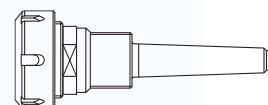

COLLET CHUCKS MORSE TAPER
Page 7.10

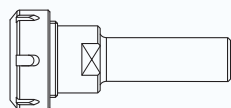

COLLET CHUCKS CYL SHANK Ø 20
Page 7.10

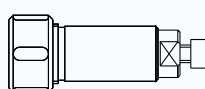

COLLET CHUCKS CYL SHANK Ø 25
Page 7.10

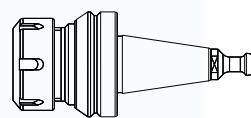

**COLLET CHUCKS ISO 30
TAPERED FLANGE**
Page 7.10

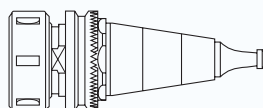

COLLET CHUCKS ISO 30
Page 7.11

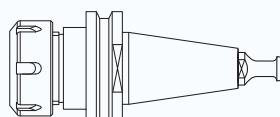

COLLET CHUCKS ISO 30
Page 7.11

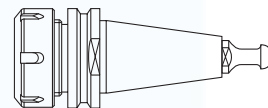

COLLET CHUCKS ISO 30
Page 7.11

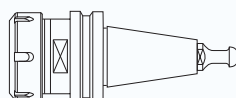

COLLET CHUCKS ISO 30
Page 7.12

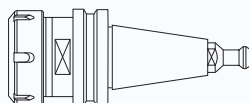

COLLET CHUCKS ISO 30
Page 7.12

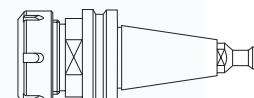

COLLET CHUCKS ISO 30
Page 7.13

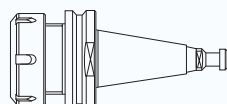

COLLET CHUCKS ISO 30
Page 7.13

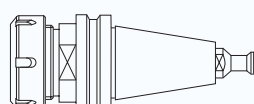

COLLET CHUCKS ISO 40
Page 7.13

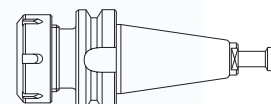

COLLET CHUCKS BT 30 - BT 35 - BT 40
Page 7.14

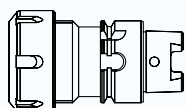

COLLET CHUCKS HSK40A
Page 7.14

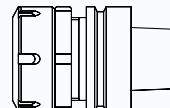

COLLET CHUCKS HSK63F
Page 7.14

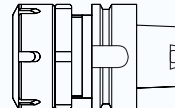

COLLET CHUCKS HSK63A
Page 7.14

Klein®



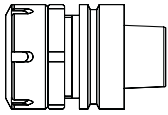

COLLET CHUCKS HSK63F
Page 7.15

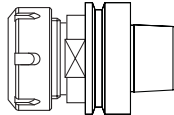

COLLET CHUCKS HSK TYPE "F"
Page 7.15

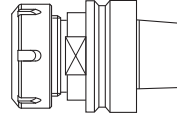

COLLET CHUCKS HSK-63E
Page 7.16

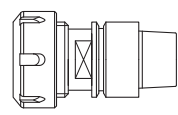

COLLET CHUCKS HSK "E"
Page 7.16

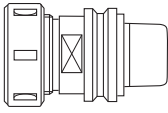

COLLET CHUCKS HSK50E 40
Page 7.16

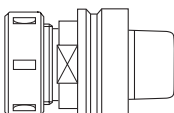

COLLET CHUCKS HSK-63F FOR MULTIAX
Page 7.17

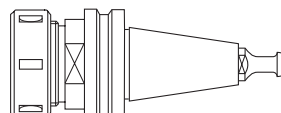

COLLET CHUCKS ISO 30 FOR MULTIAX
Page 7.17

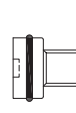

DUST PLUG
Pag. 7.17

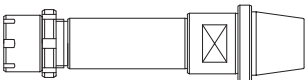

COLLET CHUCKS DIN 6499 (ER32)
Page 7.17

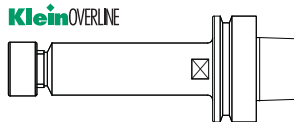

COLLET CHUCKS HSK63F ER16 - G 2.5
BALANCING
Page 7.18

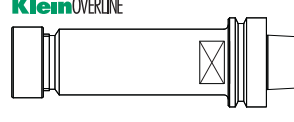

COLLET CHUCKS HSK63F ER32 - G 2.5
BALANCING
Page 7.19

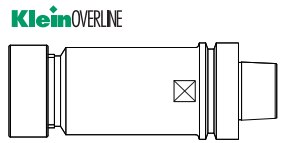

COLLET CHUCKS HSK63F
DIN6388/EOC25 - G 2.5 BALANCING
Page 7.19

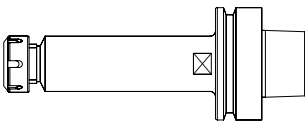

COLLET CHUCKS HSK-63F ER16
G2,5 BALANCING
Pag. 7.20

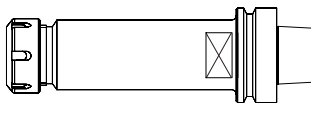

COLLET CHUCKS HSK-63F ER32
G2,5 BALANCING
Pag. 7.20

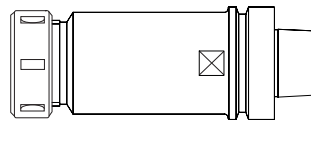

COLLET CHUCKS HSK-63F DIN388/EOC25
G2,5 BALANCING
Pag. 7.20

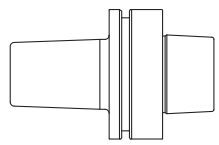

SHRINK FIT CHUCKS HSK-63F
Pag. 7.21

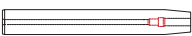

SHRINK FIT CHUCK EXTENSIONS L=150
Page 7.22



STRAIGHT SHANK TOOL EXTENSION
Page 7.22

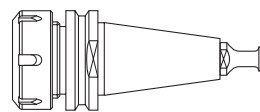

COLLET CHUCKS ISO 30 INOX
Page 7.23

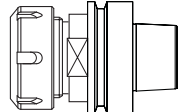

COLLET CHUCKS HSK63F INOX
Page 7.23

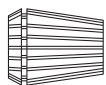

SPRING COLLETS ER 32 - DIN 6499
Page 7.25

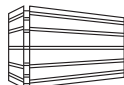

SPRING COLLETS ER 40 - DIN 6499
Page 7.25



SPRING COLLET SET ER 32 - DIN 6499
Page 7.25



SPRING COLLET SET ER 40 - DIN 6499
Page 7.25

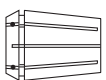

WATER-TIGHT
SPRING COLLETS ER 32 - DIN 6499
Page 7.26

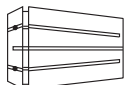

WATER-TIGHT
SPRING COLLETS ER 40 - DIN 6499
Page 7.26



WATER-TIGHT
SPRING COLLET SET ER 32 - DIN 6499
Page 7.26



WATER-TIGHT
SPRING COLLET SET ER 40 - DIN 6499
Page 7.26

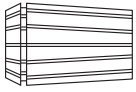

SPRING COLLETS EOC25 - DIN 6388 (462 E)
Page 7.27



SPRING COLLETS ER 25 - DIN 6499
Page 7.27



SPRING COLLETS ER 20 - DIN 6499
Page 7.27



SPRING COLLET SET ER25 - DIN 6499
Page 7.27



SPRING COLLETS ER 16 - DIN 6499
Page 7.28



SPRING COLLETS ER 11 - DIN 6499
Page 7.28

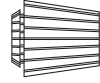

SPRING COLLETS ETS 32 - DIN 6499
Page 7.28

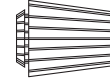

SPRING COLLETS ETS 40 - DIN 6499
Page 7.28

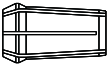

SPRING COLLETS EOC12 - DIN 6388 (407E)
Page 7.28

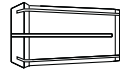

SPRING COLLETS EOC16 - DIN 6388 (415E)
Page 7.29

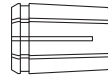

SPRING COLLETS 3° TAPER ANGLE
Page 7.29



SPRING COLLET SET + WIPE OFF KIT
Page 7.29



SET IN WOODEN BOX
Page 7.30



SET IN PLASTIC BOX
Page 7.30

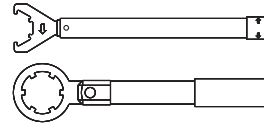

TORQUE WRENCHES
Page 7.31, 7.32

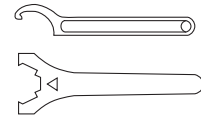

KEYS
Page 7.31

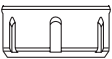

COLLET NUTS
Page 7.31



"NO-NOISE" COLLET NUTS
Page 7.32

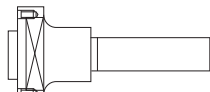

ADAPTERS FOR CIRCULAR SAWBLADES
Page 7.32

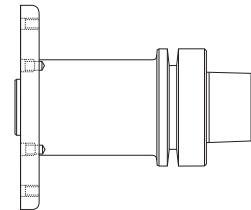

HSK-63 ADAPTERS FOR CIRCULAR SAWBLADES
Page 7.33



SECURITY FLANGE FOR SAW BLADES ADAPTERS
Page 7.33

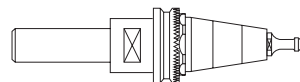

CUTTER ARBORS WITH ISO 30 TAPER
Page 7.34

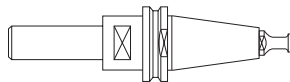

CUTTER ARBORS WITH ISO 30 - ISO 40 TAPER
Page 7.34

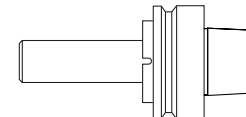

CUTTER ARBORS WITH HSK63F TAPER
Page 7.35

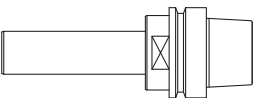

CUTTER ARBORS WITH HSK-63E TAPER
Page 7.36

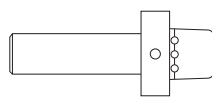

CUTTER ARBORS WITH HSK85 TAPER
Page 7.37

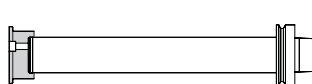

CUTTER ARBORS WITH HSK85S TAPER
Page 7.37

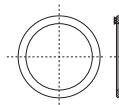

SPACERS 2-SIDES GRINDED
Page 7.38



RETAINING PAWLS FOR CONCENTRIC CHUCK
Page 7.39

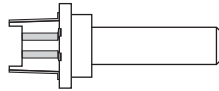

SPINDLE WIPERS
Page 7.40

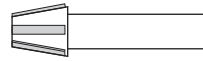

CONE AND COLLET WIPERS
Page 7.40



BRUSHES FOR COLLET BORE
Page 7.40



WIPE OFF KIT FOR CNC
Page 7.40

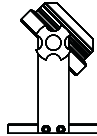

ADJUSTABLE DEMOUNT DEVICES
Page 7.41

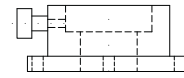

DEMOUNT DEVICES FOR FLANGE Ø80 - Ø85
Page 7.41

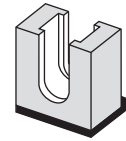

DEMOUNT DEVICES
Page 7.41

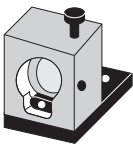

SMONTACONI ISO 30 CON FLANGIA DENTATA
Pag. 7.41



DUST & CHIP EXTRACTION NUT
Page 7.42



PROFILE CUTTERS, GROUP 1
Page 7.43



PROFILE CUTTERS, GROUP 2
Page 7.43



SOLID CARBIDE SPIRAL CUTTERS, FINISH STYLE Z=1
Page 7.46



SOLID CARBIDE SPIRAL CUTTERS, FINISH STYLE Z=1
Page 7.46



SOLID CARBIDE SPIRAL CUTTERS, FINISH STYLE Z=2
Page 7.47



SOLID CARBIDE SPIRAL CUTTERS, FINISH STYLE Z=2
Page 7.47



SOLID CARBIDE SPIRAL CUTTERS, FINISH STYLE Z=3
Page 7.48



SOLID CARBIDE SPIRAL CUTTERS, FINISH STYLE Z=3
Page 7.48



SOLID CARBIDE SPIRAL CUTTERS, ROUGHING STYLE Z=3
Page 7.49



SOLID CARBIDE SPIRAL CUTTERS, ROUGHING STYLE Z=3
Page 7.49



SOLID CARBIDE SPIRAL CUTTERS Z=3 RH ROTATION
Page 7.50



SOLID CARBIDE SPIRAL CUTTERS Z=3 LH ROTATION
Page 7.50



SOLID CARBIDE SPIRAL CUTTERS, FINISH STYLE Z=1
Page 7.50



SOLID CARBIDE SPIRAL CUTTERS, FINISH STYLE Z=1
Page 7.50



SOLID CARBIDE SPIRAL CUTTERS, FINISH STYLE Z=2
Page 7.50



SOLID CARBIDE SPIRAL CUTTERS, FINISH STYLE Z=2
Page 7.51



SOLID CARBIDE SPIRAL CUTTERS, FINISH STYLE Z=3
Page 7.51



SOLID CARBIDE SPIRAL CUTTERS, FINISH STYLE Z=3
Page 7.51



SOLID CARBIDE SPIRAL CUTTERS,
ROUGHING STYLE Z=3
Page 7.51



SOLID CARBIDE SPIRAL CUTTERS,
ROUGHING STYLE Z=3
Page 7.52



SOLID CARBIDE COMPRESSION
CUTTERS Z=1+1
Page 7.52



SOLID CARBIDE COMPRESSION
CUTTERS Z=1+1
Page 7.52



SOLID CARBIDE SPIRAL
CUTTERS Z=2 - Z=3
Page 7.52



SOLID CARBIDE SPIRAL CUTTERS
Z=3 FOR LOCKS
Page 7.52



SOLID CARBIDE COMPRESSION CUTTERS Z=2+2
SOLID CARBIDE MORTISE COMPRESSION Z=2+2
Page 7.53



SOLID CARBIDE COMPRESSION
CUTTERS Z=2+2
Pag. 7.53



SOLID CARBIDE COMPRESSION
CUTTERS Z=3+3
Page 7.54



SOLID CARBIDE MORTISE
COMPRESSION Z=3+3
Page 7.54



SOLID CARBIDE SPIRAL
CUTTERS Z=2
Page 7.54



SOLID CARBIDE SPIRAL CUTTERS Z=2
Page 7.54



SOLID CARBIDE SPIRAL CUTTERS,
FINISH STYLE S=6 Z=2
Page 7.55



SOLID CARBIDE SPIRAL CUTTERS,
FINISH STYLE S=6 Z=2
Page 7.55



SOLID CARBIDE SPIRAL CUTTERS,
FINISH STYLE S=8 Z=2
Page 7.55



SOLID CARBIDE SPIRAL CUTTERS,
FINISH STYLE S=8 Z=2
Page 7.55



SOLID CARBIDE SPIRAL CUTTERS,
FINISH STYLE Z=2
Page 7.55



HW FLUSH TRIM BITS WITH DOUBLE
BALL BEARING Z=2
Page 7.56



SOLID CARBIDE SPIRAL CUTTERS,
ROUGHING STYLE Z=2
Page 7.56



SOLID CARBIDE SPIRAL CUTTERS,
ROUGHING STYLE Z=2
Page 7.56



SOLID CARBIDE TAPERED BALL NOSE
SPIRAL BITS Z=3
Page 7.56



SOLID CARBIDE SPIRAL CUTTERS
RADIUS STYLE Z=2
Page 7.56



HS ROUTER BITS FOR "HUNDEGGER"
MACHINES
Page 7.57



HS CARVING BITS, PLANE STYLE
Page 7.57



HS CARVING BITS, ROUND STYLE
Page 7.57



SOLID CARBIDE SPIRAL CUTTERS FINISH
STYLE Z=2, KLEINDIA COATED
Pag. 7.59



SOLID CARBIDE SPIRAL CUTTERS FINISH
STYLE Z=2, KLEINDIA COATED
Page 7.59



SOLID CARBIDE SPIRAL CUTTERS ROUGHING
STYLE Z=3, KLEINDIA COATED
Page 7.59

KleinDIA



SOLID CARBIDE SPIRAL CUTTERS FOR
LOCK-CASE Z=3, KLEINDIA COATED
Pag. 7.59



MODULAR DRAWER UNIT
Page 7.63

KleinDIA



SOLID CARBIDE SPIRAL ROUTER
BITS FINISH/ROUGHING STYLE
Page 7.60

KleinDIA



SOLID CARBIDE SPIRAL ROUTER
BITS FINISH/ROUGHING STYLE
Page 7.60



7

TOOL KIT FOR CNC ROUTERS
Pag. 7.61/7.62

TOOL HOLDERS

Useful information:

SISTEMI has always been known for the high quality of the products offered. Keywords of this success are the **attention to production materials** and the use of the most modern construction techniques together with more accurate controls and the continuous research of innovative products.

A large complete stock helps even more our customers to be more competitive in the market.

The tool holders made of stainless steel (see page 7.23) allow to solve permanently any possibility of oxidation.

All our standard collet chucks are balanced at G 6.3 (24.000 RPM) and, on request, can be also at G 2.5 (36.000 RPM).

The new collet chucks Klein^{OVERLINE} (see pages 7.18, 7.19) are balanced at G 2.5 36.000 RPM for performing special executions.



Use instructions:

- 1) The collect chuck may be used only on router machines and machining centers for processing wood and wood-based material with comparable cutting characteristics.
- 2) The instructions of the machine manufacturer regarding the suitability of the clamping device have to be observed.
- 3) The direction of rotation marked on the clamping device has to be observed and followed. The direction of rotation of the tool and the collet chuck has to be the same.
- 4) Do not exceed the maximum RPM "n max" marked on the collet chuck. The maximum RPM of the system is determined by the tool, if the RPM of the tool is lower than that of the chuck.

Safety regulations:

- 1) All European and national safety regulations shall be adhered to include the safety requirements as set out in **EN 847-1, EN 847-2 and EN 847-3**.
- 2) The clamping device has to be mounted, secured and started up as per instructions of the machine manufacturer. Check the machine set-up and the direction of the rotation.

Maintenance:

A regular and **proper cleaning** of mechanical components is critical to avoid jamming during processing operations and the consequent risk of a poor finishing of the piece or even tool breakage.

The worked pieces leave impurities and debris in the collets holes, in the seats of tool holders or electro-spindles. These should be therefore cleaned daily using the **right wipers** (see items T137 and X137 at page 7.40)



In order to avoid the risk of tool breakage during the job, make sure you answered the following questions:

- 1- Are you using the proper tool for the desired job?
- 2- Collets and tool holders are clean and the tool is inserted properly?
- 3- RPM and feed speed are correct?
- 4- Is the depth cut not too excessive for the material processed?
- 5- Are there any evident vibrations of the mechanical parts?
- 6- No right answer to your problem? Stop running parts and check with your "**Klein**" distributor.

If you have to contact your distributor of technical support, please have ready the following information:

- a- Type of machine being used
- b- Type of material being cut
- c- Part number of tool, "**Klein**" item
- d- RPM/feed speed/depth of cut
- e- How long did the tool worked before it broke/damaged?
- f- Have you already done this operation in the past using the same tool?

SAFETY NORMS

Table 1.1: Calculation of the minimum clamping length (Safety regulation EN847-1).

On the tool shank the minimum clamping length is marked.
 The shank has to be clamped as far as possible, but at least up to the marking of the minimum clamping length (K).
 The free shank length (Lo) should be as short as possible, granting a higher rigidity and smaller risk of tool breakage.

| Shank diameter S (mm) | Min. clamping length K (mm) |
|-----------------------|-----------------------------|
| $S \leq 10$ | $K \geq 20$ |
| $10 < S < 25$ | $K = S \times 2$ |
| $S \geq 25$ | $K = S \times 1,8$ |

WRONG ASSEMBLING

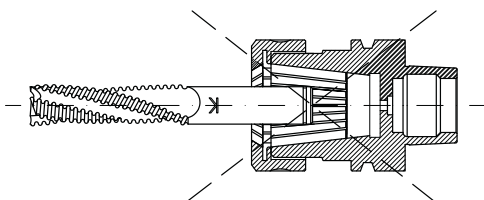

OPTIMIZED CLAMPING LENGTH

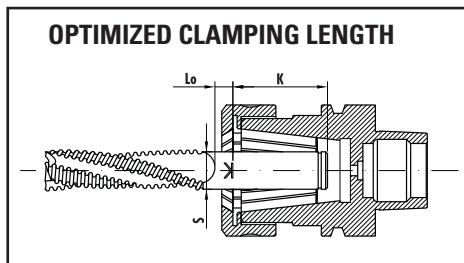

WRONG ASSEMBLING

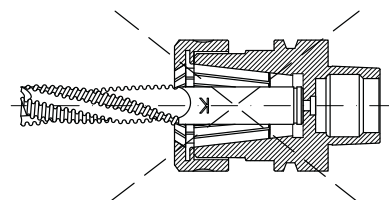

Safety norm for the calculation of the minimum clamping length

- D = Tool diameter
- B = Maximum safe length of the tool
- S = Shank diameter

COLLET CHUCKS ISO30

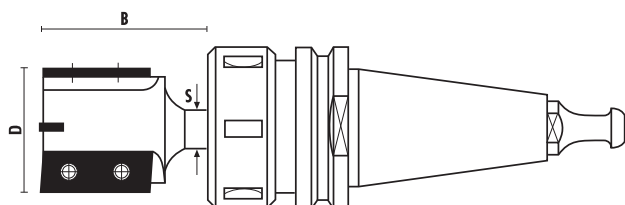

COLLET CHUCKS HSK63F

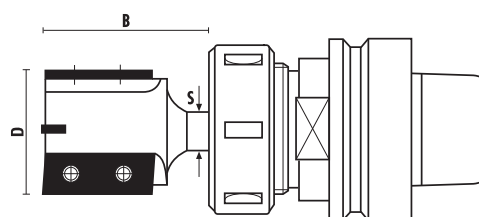

Table 2.1: Method for the calculation of the measure B for collet chucks ISO30

| D (mm) | S (mm) | | | | | | | | |
|--------|--------|-----|------|------|------|------|------|------|------|
| | Ø 6 | Ø 8 | Ø 10 | Ø 12 | Ø 14 | Ø 16 | Ø 18 | Ø 20 | Ø 25 |
| 6 | 81 | | | | | | | | |
| 8 | 66 | 94 | | | | | | | |
| 10 | 59 | 82 | 105 | | | | | | |
| 12 | 53 | 73 | 94 | 115 | | | | | |
| 14 | 48 | 66 | 85 | 105 | 124 | | | | |
| 16 | 44 | 61 | 78 | 96 | 114 | 133 | | | |
| 18 | 41 | 57 | 73 | 89 | 106 | 123 | 140 | | |
| 20 | 38 | 53 | 68 | 84 | 99 | 115 | 132 | 148 | |
| 25 | | 45 | 59 | 72 | 86 | 100 | 114 | 129 | 153 |
| 30 | | 40 | 52 | 64 | 77 | 89 | 102 | 115 | 125 |
| 35 | | | 47 | 58 | 69 | 81 | 92 | 104 | 106 |
| 40 | | | 43 | 53 | 64 | 74 | 85 | 91 | 92 |
| 45 | | | | 49 | 59 | 68 | 78 | 80 | 81 |
| 50 | | | | 46 | 55 | 64 | 71 | 71 | 73 |
| 55 | | | | | 51 | 60 | 64 | 64 | 66 |
| 60 | | | | | 48 | 56 | 58 | 59 | 60 |
| 65 | | | | | 46 | 52 | 53 | 54 | 56 |
| 70 | | | | | | 48 | 49 | 50 | 52 |
| 75 | | | | | | 46 | 47 | 49 | 51 |
| 80 | | | | | | | 47 | 47 | 51 |
| 85 | | | | | | | | 47 | 51 |
| 90 | | | | | | | | 47 | 50 |
| 95 | | | | | | | | 47 | 50 |
| 100 | | | | | | | | 47 | 50 |
| 105 | | | | | | | | | 49 |
| 110 | | | | | | | | | 49 |

Table 2.2: Method for the calculation of the measure B for collet chucks HSK63F

| D (mm) | S (mm) | | | | | | | | |
|--------|--------|-----|------|------|------|------|------|------|------|
| | Ø 6 | Ø 8 | Ø 10 | Ø 12 | Ø 14 | Ø 16 | Ø 18 | Ø 20 | Ø 25 |
| 6 | 81 | | | | | | | | |
| 8 | 68 | 94 | | | | | | | |
| 10 | 59 | 82 | 105 | | | | | | |
| 12 | 53 | 73 | 94 | 115 | | | | | |
| 14 | 48 | 66 | 85 | 105 | 124 | | | | |
| 16 | 44 | 61 | 78 | 96 | 114 | 133 | | | |
| 18 | 41 | 57 | 73 | 89 | 106 | 123 | 140 | | |
| 20 | 38 | 53 | 68 | 84 | 99 | 115 | 132 | 148 | |
| 25 | | 45 | 59 | 72 | 86 | 100 | 114 | 129 | 165 |
| 30 | | 40 | 52 | 64 | 77 | 89 | 102 | 115 | 147 |
| 35 | | | 47 | 58 | 69 | 81 | 92 | 104 | 133 |
| 40 | | | | 43 | 53 | 64 | 74 | 85 | 95 |
| 45 | | | | | 49 | 59 | 68 | 78 | 88 |
| 50 | | | | | 46 | 55 | 64 | 73 | 83 |
| 55 | | | | | | 51 | 60 | 69 | 78 |
| 60 | | | | | | 48 | 56 | 65 | 73 |
| 65 | | | | | | 46 | 53 | 61 | 69 |
| 70 | | | | | | | 51 | 59 | 66 |
| 75 | | | | | | | 48 | 55 | 63 |
| 80 | | | | | | | | 53 | 60 |
| 85 | | | | | | | | | 51 |
| 90 | | | | | | | | 49 | 56 |
| 95 | | | | | | | | | 56 |
| 100 | | | | | | | | | 52 |
| 105 | | | | | | | | | 65 |
| 110 | | | | | | | | | 64 |

HW ROUTER BITS Z=2

ART. T110

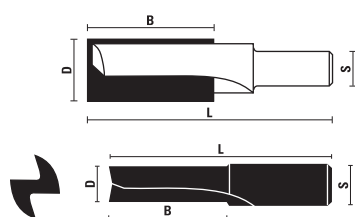

| RH rotation | D | B | L | S |
|--------------|----|----|----|--------|
| T110.030.R ▲ | 3 | 8 | 38 | 9,5x20 |
| T110.040.R ▲ | 4 | 10 | 39 | 9,5x20 |
| T110.050.R ▲ | 5 | 12 | 41 | 9,5x20 |
| T110.060.R ▲ | 6 | 16 | 43 | 9,5x20 |
| T110.070.R ▲ | 7 | 18 | 45 | 9,5x20 |
| T110.080.R ▲ | 8 | 20 | 48 | 9,5x20 |
| T110.081.R ▲ | 8 | 30 | 60 | 9,5x20 |
| T110.090.R ▲ | 9 | 22 | 52 | 9,5x20 |
| T110.100.R ▲ | 10 | 24 | 52 | 9,5x20 |
| T110.101.R ▲ | 10 | 35 | 65 | 9,5x20 |
| T110.110.R | 11 | 30 | 60 | 9,5x20 |
| T110.120.R | 12 | 30 | 60 | 12x20 |
| T110.121.R ▲ | 12 | 40 | 70 | 12x20 |
| T110.130.R | 13 | 30 | 60 | 12x20 |
| T110.140.R | 14 | 40 | 65 | 12x20 |
| T110.150.R | 15 | 40 | 65 | 12x20 |
| T110.160.R | 16 | 40 | 65 | 12x20 |
| T110.180.R | 18 | 40 | 70 | 12x20 |
| T110.200.R | 20 | 40 | 70 | 12x20 |
| T110.220.R | 22 | 40 | 70 | 12x20 |
| T110.240.R | 24 | 40 | 70 | 12x20 |
| T110.250.R | 25 | 40 | 70 | 12x20 |
| T110.260.R | 26 | 42 | 70 | 12x20 |
| T110.280.R | 28 | 42 | 70 | 12x20 |
| T110.300.R | 30 | 42 | 70 | 12x20 |

▲ Solid carbide

VHW ROUTER BITS Z=2

ART. T112



- Solid carbide
- Indicated for plastic and acrylic material, plexiglass, polypropylene etc.
- "O" flute straight

| RH rotation | D | B | L | S |
|-------------|----|----|----|----|
| T112.050.R | 5 | 12 | 48 | 5 |
| T112.060.R | 6 | 14 | 50 | 6 |
| T112.080.R | 8 | 18 | 55 | 8 |
| T112.100.R | 10 | 20 | 58 | 10 |
| T112.120.R | 12 | 26 | 64 | 12 |

CONCENTRIC CHUCKS S=MK2

ART. T116

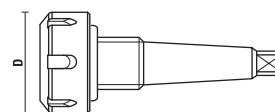

- Wrench art. Z052.301.N
- Spare parts see page 10.07

Supplied with nut (without collet)

| Item | D | Shank | Clamping nut |
|------------|----|----------------|--------------|
| T116.100.R | 40 | C.M. 2/FIL M20 | Z091.000.R |
| T116.100.L | 40 | C.M. 2/FIL M20 | Z091.000.L |

CONCENTRIC CHUCKS

ART. T116

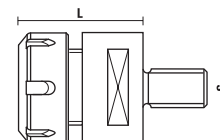

- Wrench art. Z052.301.N
- Spare parts see page 10.07



Item X116
Set in wooden box

- With spare collets Art. T117
- To use on spindle moulder
- Supplied with nut (without collet)

| RH rotation | S | L | Clamping nut |
|-------------|-----|----|--------------|
| T116.500.R | M16 | 42 | Z091.000.R |
| T116.501.R | M14 | 42 | Z091.000.R |
| T116.502.R | M18 | 42 | Z091.000.R |
| T116.503.R | M20 | 42 | Z091.000.R |

| | |
|------------|--|
| X116.500.R | Set with chuck M16 + 3 spring collets Ø 6/8/12 |
| X116.501.R | Set with chuck M14 + 3 spring collets Ø 6/8/12 |
| X116.502.R | Set with chuck M18 + 3 spring collets Ø 6/8/12 |
| X116.503.R | Set with chuck M20 + 3 spring collets Ø 6/8/12 |

SPRING COLLETS

ART. T117

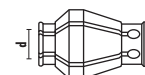

For Art. T116

| Item | d | Item | d |
|------------|------|------------|-------|
| T117.060.N | Ø6 | T117.110.N | Ø11 |
| T117.064.N | Ø6,4 | T117.120.N | Ø12 |
| T117.080.N | Ø8 | T117.127.N | Ø12,7 |
| T117.090.N | Ø9 | T117.130.N | Ø13 |
| T117.095.N | Ø9,5 | T117.140.N | Ø14 |
| T117.100.N | Ø10 | | |

COLLET CHUCKS MORSE TAPER

ART. T118

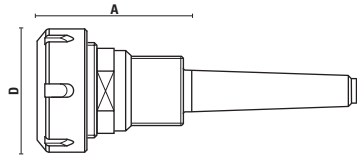

- Supplied with nut (without collet)
- Threaded nut and wrenches see page 7.31, spring collets see page 7.25
- Threaded nut DIN 6499
- The "A" measure will be determined with clamped tool shanks by using our spring collet DIN6499. The "A" measure may be subject to variations depending on the diameter of the clamped tools.

| Item | Shank | A | D | Spring collets | Clamping nut | Rot. |
|------------|----------------|----|----|-------------------------|-----------------------------|-------|
| T118.200.R | MK2 / FIL. M30 | 70 | 50 | ∅ 2÷20 (Art. T119/ER32) | Z091.001.R | RH |
| T118.200.L | MK2 / FIL. M30 | 70 | 50 | ∅ 2÷20 (Art. T119/ER32) | Z091.001.L | LH |
| T118.202.R | MK2 / FIL. M30 | 70 | 50 | ∅ 2÷20 (Art. T119/ER32) | Z091.101.R ball bearing nut | RH/LH |
| T118.300.R | MK3 / FIL. M30 | 70 | 50 | ∅ 2÷20 (Art. T119/ER32) | Z091.001.R | RH |
| T118.300.L | MK3 / FIL. M30 | 70 | 50 | ∅ 2÷20 (Art. T119/ER32) | Z091.001.L | LH |
| T118.302.R | MK3 / FIL. M30 | 70 | 50 | ∅ 2÷20 (Art. T119/ER32) | Z091.101.R ball bearing nut | RH/LH |

COLLET CHUCKS CYL SHANK ∅ 20

ART. T118

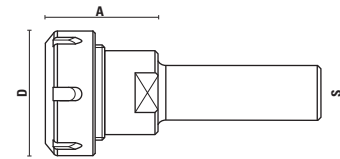

- Supplied with nut (without collet)
- Threaded nut and wrenches see page 7.31, spring collets see page 7.25
- Threaded nut DIN 6499
- The "A" measure will be determined with clamped tool shanks by using our spring collet DIN6499. The "A" measure may be subject to variations depending on the diameter of the clamped tools.

| Item | S | A | D | Spring collets | Clamping nut | Rot. |
|------------|------|----|----|-------------------------|-----------------------------|-------|
| T118.400.R | ∅ 20 | 51 | 50 | ∅ 2÷20 (Art. T119/ER32) | Z091.001.R | RH |
| T118.402.R | ∅ 20 | 51 | 50 | ∅ 2÷20 (Art. T119/ER32) | Z091.101.R ball bearing nut | RH/LH |

COLLET CHUCKS CYL SHANK ∅ 25

ART. T118

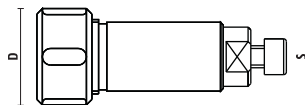

- Supplied with nut (without collet)
- Threaded nut and wrenches see page 7.31, spring collets see page 7.28
- Threaded nut DIN 6388/EOC12

- For: **Weeke**

| Item | S | D | Spring collets | Clamping nut | Rot. |
|------------|------|----|----------------------------|--------------|------|
| T118.580.R | ∅ 25 | 35 | ∅ 1÷12,7 (Art. T136/EOC12) | Z091.205.R | RH |

COLLET CHUCKS ISO 30 TAPERED FLANGE

ART. T118

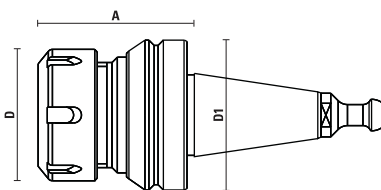

- Supplied with nut (without collet) and retaining pawl
- Threaded nut and wrenches see page 7.31, spring collets see page 7.25
- Threaded nut DIN 6499
- The "A" measure will be determined with clamped tool shanks by using our spring collet DIN6499. The "A" measure may be subject to variations depending on the diameter of the clamped tools.

- Retaining pawl T118.891.R for: **Thermwood, Vitap**

| Item | A | D | D1 | Spring collets | Clamping nut | Rot. |
|------------|----|----|----|-------------------------|--------------|------|
| T118.680.R | 58 | 50 | 57 | ∅ 2÷20 (Art. T119/ER32) | Z091.001.R | RH |

COLLET CHUCKS ISO 30

ART. T118

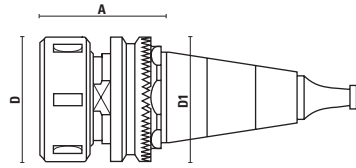

- Supplied with nut (without collet) and retaining pawl
- Threaded nut and wrenches see page 7.31, spring collets see page 7.25, 7.27
- Threaded nut DIN 6499
- Threaded nut DIN 6388/EOC25
- The "A" measure will be determined with clamped tool shanks by using our spring collet DIN6499 - DIN 6388/EOC25. The "A" measure may be subject to variations depending on the diameter of the clamped tools

With anti-adherent surface treatment "Impreglon"

- Retaining pawl T118.790.R for: **Morbidelli, SCM**

| Item | Taper | A | D | D1 | Spring collets | Clamping nut | Rot. |
|------------------------|--------|----|----|----|--------------------------|-----------------------------|-------|
| T118.700.R | ISO 30 | 55 | 50 | 49 | ∅ 2÷20 (Art. T119/ER32) | Z091.001.R | RH |
| T118.702.R | ISO 30 | 55 | 50 | 49 | ∅ 2÷20 (Art. T119/ER32) | Z091.101.R ball bearing nut | RH/LH |
| T118.701.R | ISO 30 | 71 | 60 | 49 | ∅ 3÷25 (Art. T124/EOC25) | Z091.203.R ball bearing nut | RH/LH |
| T118.711.R | ISO 30 | 71 | 60 | 49 | ∅ 3÷25 (Art. T124/EOC25) | Z091.202.R | RH |
| T118.711.L selling out | ISO 30 | 71 | 60 | 49 | ∅ 3÷25 (Art. T124/EOC25) | Z091.202.L | LH |

COLLET CHUCKS ISO 30

ART. T118

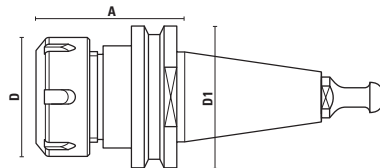

- Supplied with nut (without collet) and retaining pawl
- Threaded nut and wrenches see page 7.31, spring collets see page 7.25
- Threaded nut DIN 6499
- The "A" measure will be determined with clamped tool shanks by using our spring collet DIN6499. The "A" measure may be subject to variations depending on the diameter of the clamped tools

- Retaining pawl T118.891.R for: **Biesse** (after il 09/09/92), **Masterwood - Bulleri** (motor H.S.D.), **Vitap**

| Item | Taper | A | D | D1 | Spring collets | Clamping nut | Rot. |
|-----------------------|--------|----|----|----|-------------------------|--------------|------|
| T118.796.R NEW | ISO 30 | 50 | 32 | 50 | ∅ 2÷10 (Art. T127/ER16) | Z091.105.R | RH |
| T118.797.R NEW | ISO 30 | 50 | 35 | 50 | ∅ 2÷12 (Art. T126/ER20) | Z091.104.R | RH |
| T118.798.R NEW | ISO 30 | 50 | 42 | 50 | ∅ 3÷16 (Art. T125/ER25) | Z091.103.R | RH |

COLLET CHUCKS ISO 30

ART. T118

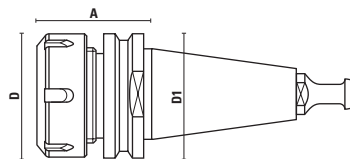

- Supplied with nut (without collet) and retaining pawl
- Threaded nut and wrenches see page 7.31, spring collets see page 7.25
- Threaded nut DIN 6499
- The "A" measure will be determined with clamped tool shanks by using our spring collet DIN6499. The "A" measure may be subject to variations depending on the diameter of the clamped tools.

- Retaining pawl T118.891.R for: **Biesse** (after il 09/09/92), **Masterwood - Bulleri** (motor H.S.D.), **Vitap**

| Item | Taper | A | D | D1 | Spring collets | Clamping nut | Rot. |
|------------|--------|----|----|----|-------------------------|-----------------------------|-------|
| T118.800.R | ISO 30 | 50 | 50 | 50 | ∅ 2÷20 (Art. T119/ER32) | Z091.001.R | RH |
| T118.800.L | ISO 30 | 50 | 50 | 50 | ∅ 2÷20 (Art. T119/ER32) | Z091.001.L | LH |
| T118.802.R | ISO 30 | 50 | 50 | 50 | ∅ 2÷20 (Art. T119/ER32) | Z091.101.R ball bearing nut | RH/LH |
| T118.830.R | ISO 30 | 60 | 63 | 50 | ∅ 2÷30 (Art. T123/ER40) | Z091.002.R | RH |
| T118.830.L | ISO 30 | 60 | 63 | 50 | ∅ 2÷30 (Art. T123/ER40) | Z091.002.L | LH |
| T118.832.R | ISO 30 | 60 | 63 | 50 | ∅ 2÷30 (Art. T123/ER40) | Z091.102.R ball bearing nut | RH/LH |

COLLET CHUCKS ISO 30

ART. T118

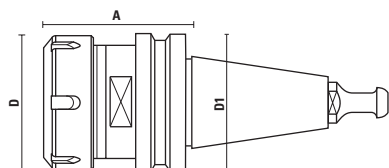

- Supplied with nut (without collet) and retaining pawl
- Threaded nut and wrenches see page 7.31, spring collets see page 7.25
- Threaded nut DIN 6499
- The "A" measure will be determined with clamped tool shanks by using our spring collet DIN6499. The "A" measure may be subject to variations depending on the diameter of the clamped tools.

- Retaining pawl T118.891.R for: **Biesse** (after 09/09/92), **Masterwood - Bulleri** (motor H.S.D.), **Vitap**

| Item | Taper | A | D | D1 | Spring collets | Clamping nut | Rot. |
|------------|--------|----|----|----|-------------------------|-----------------------------|-------|
| T118.804.R | ISO 30 | 68 | 50 | 50 | ∅ 2÷20 (Art. T119/ER32) | Z091.001.R | RH |
| T118.804.L | ISO 30 | 68 | 50 | 50 | ∅ 2÷20 (Art. T119/ER32) | Z091.001.L | LH |
| T118.806.R | ISO 30 | 68 | 50 | 50 | ∅ 2÷20 (Art. T119/ER32) | Z091.101.R ball bearing nut | RH/LH |
| T118.834.R | ISO 30 | 68 | 63 | 50 | ∅ 2÷30 (Art. T123/ER40) | Z091.002.R | RH |
| T118.834.L | ISO 30 | 68 | 63 | 50 | ∅ 2÷30 (Art. T123/ER40) | Z091.002.L | LH |
| T118.836.R | ISO 30 | 68 | 63 | 50 | ∅ 2÷30 (Art. T123/ER40) | Z091.102.R ball bearing nut | RH/LH |

COLLET CHUCKS ISO 30

ART. T118

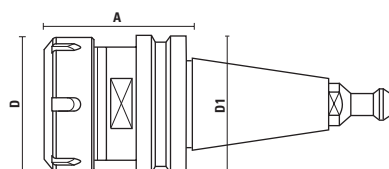

- Supplied with nut (without collet) and retaining pawl
- Threaded nut and wrenches see page 7.31, spring collets see page 7.25, 7.28
- Threaded nut DIN 6499
- The "A" measure will be determined with clamped tool shanks by using our spring collet DIN6499. The "A" measure may be subject to variations depending on the diameter of the clamped tools.

- Retaining pawl T118.792.R for: **Alberti, Vitap, Masterwood** (motor G. Colombo)

| Item | Taper | A | D | D1 | Spring collets | Clamping nut | Rot. |
|------------|--------|----|----|----|-------------------------|-----------------------------|-------|
| T118.810.R | ISO 30 | 68 | 50 | 50 | ∅ 2÷20 (Art. T119/ER32) | Z091.001.R | RH |
| T118.810.L | ISO 30 | 68 | 50 | 50 | ∅ 2÷20 (Art. T119/ER32) | Z091.001.L | LH |
| T118.812.R | ISO 30 | 68 | 50 | 50 | ∅ 2÷20 (Art. T119/ER32) | Z091.101.R ball bearing nut | RH/LH |
| T118.814.R | ISO 30 | 68 | 63 | 50 | ∅ 2÷30 (Art. T123/ER40) | Z091.002.R | RH |
| T118.814.L | ISO 30 | 68 | 63 | 50 | ∅ 2÷30 (Art. T123/ER40) | Z091.002.L | LH |
| T118.816.R | ISO 30 | 68 | 63 | 50 | ∅ 2÷30 (Art. T123/ER40) | Z091.102.R ball bearing nut | RH/LH |

- Retaining pawl T118.791.R (DIN 69872) for: **Anderson, Busellato, Weeke, Ima, Bulleri, Maka, Cosmec, Reichenbacher**

| Item | Taper | A | D | D1 | Spring collets | Clamping nut | Rot. |
|------------|--------|----|----|----|-------------------------|-----------------------------|-------|
| T118.820.R | ISO 30 | 68 | 50 | 50 | ∅ 2÷20 (Art. T119/ER32) | Z091.001.R | RH |
| T118.820.L | ISO 30 | 68 | 50 | 50 | ∅ 2÷20 (Art. T119/ER32) | Z091.001.L | LH |
| T118.822.R | ISO 30 | 68 | 50 | 50 | ∅ 2÷20 (Art. T119/ER32) | Z091.101.R ball bearing nut | RH/LH |
| T118.824.R | ISO 30 | 68 | 63 | 50 | ∅ 2÷30 (Art. T123/ER40) | Z091.002.R | RH |
| T118.824.L | ISO 30 | 68 | 63 | 50 | ∅ 2÷30 (Art. T123/ER40) | Z091.002.L | LH |
| T118.826.R | ISO 30 | 68 | 63 | 50 | ∅ 2÷30 (Art. T123/ER40) | Z091.102.R ball bearing nut | RH/LH |

- Retaining pawl T118.794.R for: **CMS** (flange ∅ 46)

| Item | Taper | A | D | D1 | Spring collets | Clamping nut | Rot. |
|------------|--------|----|----|----|--------------------------|--------------|------|
| T118.880.R | ISO 30 | 52 | 50 | 46 | ∅ 3÷20 (Art. T134/ETS32) | Z091.301.R | RH |
| T118.881.R | ISO 30 | 52 | 50 | 46 | ∅ 3÷20 (Art. T119/ER32) | Z091.001.R | RH |
| T118.882.R | ISO 30 | 57 | 63 | 46 | ∅ 4÷25 (Art. T135/ETS40) | Z091.302.R | RH |
| T118.883.R | ISO 30 | 57 | 63 | 46 | ∅ 4÷25 (Art. T123/ER40) | Z091.002.R | RH |

COLLET CHUCKS ISO 30

ART. T118

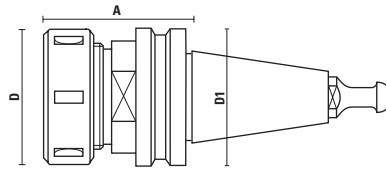

- Supplied with nut (without collet) and retaining pawl
- Threaded nut and wrenches see page 7.31, spring collets see page 7.27
- Threaded nut DIN 6388 (EOC25)
- The "A" measure will be determined with clamped tool shanks by using our spring collet DIN 6388 (EOC25). The "A" measure may be subject to variations depending on the diameter of the clamped tools.
- Retaining pawl T118.791.R (DIN 69872) for: **Anderson, Busellato, Weeke, Ima, Bulleri, Maka, Cosmec, Reichenbacher**

| Item | Taper | A | D | D1 | Spring collets | Clamping nut | Rot. |
|------------|--------|----|----|----|--------------------------|-----------------------------|-------|
| T118.828.R | ISO 30 | 68 | 60 | 50 | ∅ 3÷25 (Art. T124/EOC25) | Z091.202.R | RH |
| T118.829.R | ISO 30 | 68 | 60 | 50 | ∅ 3÷25 (Art. T124/EOC25) | Z091.203.R ball bearing nut | RH/LH |

- Retaining pawl T118.891.R for: **Biesse** (after 09/09/92), **Masterwood - Bulleri** (motor H.S.D.), **Vitap**

| Item | Taper | A | D | D1 | Spring collets | Clamping nut | Rot. |
|------------|--------|----|----|----|--------------------------|-----------------------------|-------|
| T118.838.R | ISO 30 | 68 | 60 | 50 | ∅ 3÷25 (Art. T124/EOC25) | Z091.202.R | RH |
| T118.839.R | ISO 30 | 68 | 60 | 50 | ∅ 3÷25 (Art. T124/EOC25) | Z091.203.R ball bearing nut | RH/LH |

COLLET CHUCKS ISO 30

ART. T118

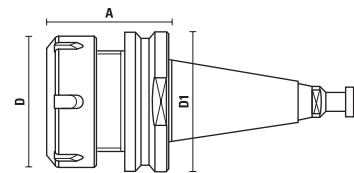

- Supplied with nut (without collet) and retaining pawl
- Threaded nut and wrenches see page 7.31, spring collets see page 7.25
- Threaded nut DIN 6499
- The "A" measure will be determined with clamped tool shanks by using our spring collet DIN6499. The "A" measure may be subject to variations depending on the diameter of the clamped tools.

- Retaining pawl T118.791.R for: electrospindles **Anderson, Elte**

| Item | Taper | A | D | D1 | Spring collets | Clamping nut | Rot. |
|------------|--------|----|----|----|-------------------------|-----------------------------|-------|
| T118.845.R | ISO 30 | 50 | 50 | 58 | ∅ 2÷20 (Art. T119/ER32) | Z091.001.R | RH |
| T118.846.R | ISO 30 | 50 | 50 | 58 | ∅ 2÷20 (Art. T119/ER32) | Z091.101.R ball bearing nut | RH/LH |
| T118.847.R | ISO 30 | 56 | 63 | 58 | ∅ 2÷30 (Art. T123/ER40) | Z091.002.R | RH |
| T118.848.R | ISO 30 | 56 | 63 | 58 | ∅ 2÷30 (Art. T123/ER40) | Z091.102.R ball bearing nut | RH/LH |

- Retaining pawl T118.793.R for: **Esseteam** (solid flange)

| Item | Taper | A | D | D1 | Spring collets | Clamping nut | Rot. |
|------------|--------|----|----|----|-------------------------|-----------------------------|-------|
| T118.861.R | ISO 30 | 50 | 50 | 58 | ∅ 2÷20 (Art. T119/ER32) | Z091.001.R | RH |
| T118.862.R | ISO 30 | 50 | 50 | 58 | ∅ 2÷20 (Art. T119/ER32) | Z091.101.R ball bearing nut | RH/LH |
| T118.864.R | ISO 30 | 56 | 63 | 58 | ∅ 2÷30 (Art. T123/ER40) | Z091.002.R | RH |
| T118.866.R | ISO 30 | 56 | 63 | 58 | ∅ 2÷30 (Art. T123/ER40) | Z091.102.R ball bearing nut | RH/LH |

COLLET CHUCKS ISO 40

ART. T118

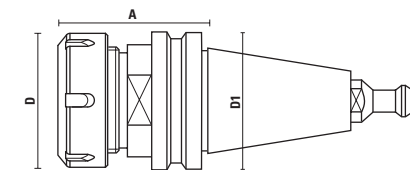

- Supplied with nut (without collet) and retaining pawl
- Threaded nut and wrenches see page 7.31, spring collets see page 7.25
- Threaded nut DIN 6499
- The "A" measure will be determined with clamped tool shanks by using our spring collet DIN6499. The "A" measure may be subject to variations depending on the diameter of the clamped tools.

- Retaining pawl T118.893.R for: **IMA, Weeke, Maka, Reichenbacher, Stegherr**

| Item | Taper | A | D | D1 | Spring collets | Clamping nut | Rot. |
|------------|--------|----|----|------|-------------------------|-----------------------------|-------|
| T118.850.R | ISO 40 | 73 | 50 | 63,5 | ∅ 2÷20 (Art. T119/ER32) | Z091.001.R | RH |
| T118.852.R | ISO 40 | 73 | 50 | 63,5 | ∅ 2÷20 (Art. T119/ER32) | Z091.101.R ball bearing nut | RH/LH |
| T118.870.R | ISO 40 | 73 | 63 | 63,5 | ∅ 2÷30 (Art. T123/ER40) | Z091.002.R | RH |
| T118.872.R | ISO 40 | 73 | 63 | 63,5 | ∅ 2÷30 (Art. T123/ER40) | Z091.102.R ball bearing nut | RH/LH |

COLLET CHUCKS BT 30 - BT 35 - BT 40

ART. T118

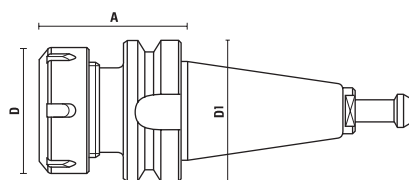

- Supplied with nut (without collet) and retaining pawl
- Threaded nut and wrenches see page 7.31, spring collets see page 7.25
- Threaded nut DIN 6499
- The "A" measure will be determined with clamped tool shanks by using our spring collet DIN6499. The "A" measure may be subject to variations depending on the diameter of the clamped tools
- Retaining pawl T118.895.R for: BT 30 **Shoda**
- Retaining pawl T118.896.R for: BT 35 **Heian (1)**
- Retaining pawl T118.896.R030 for: BT 35 **Heian (2)**
- Retaining pawl T118.897.R for: BT 40 **Shoda**

| Item | Taper | A | D | D1 | Spring collets | Clamping nut | Rot. |
|------------|-----------|----|----|----|-------------------------|-----------------------------|-------|
| T118.910.R | BT 30 | 60 | 50 | 46 | ∅ 2÷20 (Art. T119/ER32) | Z091.101.R ball bearing nut | RH/LH |
| T118.912.R | BT 30 | 70 | 63 | 46 | ∅ 2÷30 (Art. T123/ER40) | Z091.102.R ball bearing nut | RH/LH |
| T118.920.R | BT 35 (1) | 69 | 50 | 53 | ∅ 2÷20 (Art. T119/ER32) | Z091.101.R ball bearing nut | RH/LH |
| T118.921.R | BT 35 (2) | 69 | 50 | 53 | ∅ 2÷20 (Art. T119/ER32) | Z091.101.R ball bearing nut | RH/LH |
| T118.922.R | BT 35 (1) | 60 | 63 | 53 | ∅ 2÷30 (Art. T123/ER40) | Z091.102.R ball bearing nut | RH/LH |
| T118.923.R | BT 35 (2) | 60 | 63 | 53 | ∅ 2÷30 (Art. T123/ER40) | Z091.102.R ball bearing nut | RH/LH |
| T118.930.R | BT 40 | 65 | 50 | 63 | ∅ 2÷20 (Art. T119/ER32) | Z091.101.R ball bearing nut | RH/LH |

COLLET CHUCKS HSK-40A

ART. T118

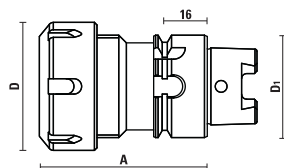

- Supplied with nut (without collet)
- Threaded nut and wrenches see page 7.31, spring collets see page 7.25
- Threaded nut DIN 6499
- The "A" measure will be determined with clamped tool shanks by using our spring collet DIN6499. The "A" measure may be subject to variations depending on the diameter of the clamped tools
- The hollow taper shank is produced according to DIN69893 for inserting the Balluff microchip
- For "Centrauro"

| Item | Taper | A | D | D1 | Spring collets | Clamping nut | Rot. |
|------------|---------|----|----|----|-------------------------|--------------|------|
| T118.950.R | HSK-40A | 65 | 50 | 40 | ∅ 2÷20 (Art. T119/ER32) | Z091.001.R | RH |

COLLET CHUCKS HSK-63F

ART. T118

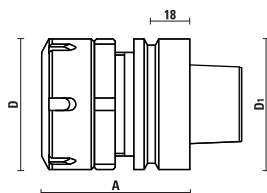

- Supplied with nut (without collet) and return ring nut
- Threaded nut and wrenches see page 7.31, spring collets see page 7.25
- Threaded nut DIN 6499
- The "A" measure will be determined with clamped tool shanks by using our spring collet DIN6499. The "A" measure may be subject to variations depending on the diameter of the clamped tools
- The hollow taper shank is produced according to DIN69893 for inserting the Balluff microchip
- For "Essetre"

| Item | Taper | A | D | D1 | Spring collets | Clamping nut | Return ring nut | Rot. |
|------------|---------|----|----|----|-------------------------|--------------|-----------------|------|
| T118.953.R | HSK-63F | 71 | 63 | 63 | ∅ 2÷30 (Art. T123/ER40) | Z091.002.R | Z091.902.R | RH |

COLLET CHUCKS HSK-63A

ART. T118

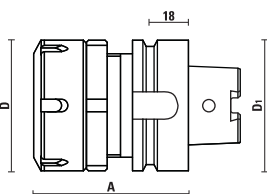

- Supplied with nut (without collet) and return ring nut
- Threaded nut and wrenches see page 7.31, spring collets see page 7.25
- Threaded nut DIN 6499
- The "A" measure will be determined with clamped tool shanks by using our spring collet DIN6499. The "A" measure may be subject to variations depending on the diameter of the clamped tools
- The hollow taper shank is produced according to DIN69893 for inserting the Balluff microchip
- For "Essetre"

| Item | Taper | A | D | D1 | Spring collets | Clamping nut | Return ring nut | Rot. |
|------------|---------|----|----|----|-------------------------|--------------|-----------------|------|
| T118.956.R | HSK-63A | 71 | 63 | 63 | ∅ 2÷30 (Art. T123/ER40) | Z091.002.R | Z091.902.R | RH |

COLLET CHUCKS HSK-63F

ART. T118

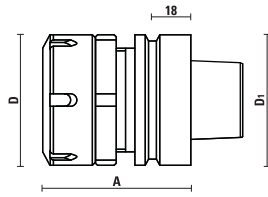

- Supplied with nut (without collet) and return ring nut
- Threaded nut and wrenches see page 7.31, spring collets see page 7.25
- Threaded nut DIN 6499
- The "A" measure will be determined with clamped tool shanks by using our spring collet DIN6499. The "A" measure may be subject to variations depending on the diameter of the clamped tools
- The hollow taper shank is produced according to DIN69893 for inserting the Balluff microchip
- For "Uniteam"

| Item | Taper | A | D | D1 | Spring collets | Clamping nut | Return ring nut | Rot. |
|------------|---------|----|----|----|-------------------------|--------------|-----------------|------|
| T118.959.R | HSK-63F | 79 | 63 | 63 | ∅ 2÷30 (Art. T123/ER40) | Z091.002.R | Z091.902.R | RH |

COLLET CHUCKS HSK TYPE "F"

ART. T118

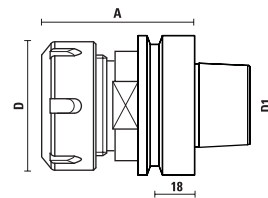

- Supplied with nut (without collet)
- Threaded nut and wrenches see page 7.31, spring collets see page 7.25, 7.27
- Threaded nut DIN 6499
- Threaded nut DIN 6388 (EOC25)
- The "A" measure will be determined with clamped tool shanks by using our spring collet DIN6499 - DIN 6388/EOC25. The "A" measure may be subject to variations depending on the diameter of the clamped tools
- The hollow taper shank is produced according to DIN69893 for inserting the Balluff microchip

| Item | Taper | A | D | D1 | Spring collets | Clamping nut | Rot. |
|-----------------------|----------|----|----|----|--------------------------|-----------------------------|-------|
| T118.962.R NEW | HSK-50F | 60 | 42 | 50 | ∅ 2÷16 (Art. T125/ER25) | Z091.103.R | RH |
| T118.966.R | HSK 50 F | 73 | 50 | 50 | ∅ 2÷20 (Art. T119/ER32) | Z091.001.R | RH |
| T118.968.R | HSK 50 F | 76 | 50 | 50 | ∅ 2÷20 (Art. T119/ER32) | Z091.101.R ball bearing nut | RH/LH |
| T118.970.R NEW | HSK-50F | 76 | 63 | 50 | ∅ 2÷30 (Art. T123/ER40) | Z091.002.R | RH |
| T118.972.R NEW | HSK-50F | 78 | 63 | 50 | ∅ 2÷30 (Art. T123/ER40) | Z091.102.R ball bearing nut | RH/LH |
| T118.974.R | HSK 50 F | 78 | 60 | 50 | ∅ 2÷26 (Art. T124/EOC25) | Z091.203.R | RH |

| Item | Taper | A | D | D1 | Spring collets | Clamping nut | Rot. |
|------------|----------|-----|----|----|--------------------------|-----------------------------|-------|
| T118.975.R | HSK 63 F | 70 | 42 | 63 | ∅ 3÷16 (Art. T125/ER25) | Z091.103.R | RH |
| T118.976.R | HSK 63 F | 75 | 50 | 63 | ∅ 2÷20 (Art. T119/ER32) | Z091.001.R | RH |
| T118.976.L | HSK 63 F | 75 | 50 | 63 | ∅ 2÷20 (Art. T119/ER32) | Z091.001.L | LH |
| T118.978.R | HSK 63 F | 76 | 50 | 63 | ∅ 2÷20 (Art. T119/ER32) | Z091.101.R ball bearing nut | RH/LH |
| T118.980.R | HSK 63 F | 75 | 63 | 63 | ∅ 2÷30 (Art. T123/ER40) | Z091.002.R | RH |
| T118.980.L | HSK 63 F | 75 | 63 | 63 | ∅ 2÷30 (Art. T123/ER40) | Z091.002.L | LH |
| T118.982.R | HSK 63 F | 78 | 63 | 63 | ∅ 2÷30 (Art. T123/ER40) | Z091.102.R ball bearing nut | RH/LH |
| T118.983.R | HSK 63 F | 78 | 60 | 63 | ∅ 3÷26 (Art. T124/EOC25) | Z091.202.R | RH |
| T118.984.R | HSK 63 F | 78 | 60 | 63 | ∅ 3÷26 (Art. T124/EOC25) | Z091.203.R ball bearing nut | RH/LH |
| T118.994.R | HSK 63 F | 115 | 60 | 63 | ∅ 2÷26 (Art. T124/EOC25) | Z091.203.R ball bearing nut | RH/LH |

COLLET CHUCKS HSK-63E

ART. T118

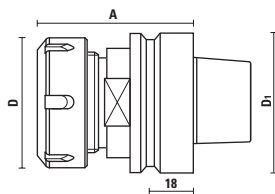

- Supplied with nut (without collet)
- Threaded nut and wrenches see page 7.31, spring collets see page 7.25, 7.28
- Threaded nut DIN 6499
- The "A" measure will be determined with clamped tool shanks by using our spring collet DIN6499. The "A" measure may be subject to variations depending on the diameter of the clamped tools
- The hollow taper shank is produced according to DIN69893 for inserting the Balluff microchip

| Item | Taper | A | D | D1 | Spring collets | Clamping nut | Rot. |
|--------------------------|---------|-----|----|----|--------------------------|--------------|------|
| T118.985.R | HSK-63E | 76 | 50 | 63 | ∅ 2÷20 (Art. T119/ER32) | Z091.001.R | RH |
| T118.985.R100 NEW | HSK-63E | 100 | 50 | 63 | ∅ 2÷20 (Art. T119/ER32) | Z091.001.R | RH |
| T118.986.R | HSK-63E | 76 | 50 | 63 | ∅ 2÷30 (Art. T134/ETS32) | Z091.301.R | RH |
| T118.987.R | HSK-63E | 76 | 63 | 63 | ∅ 2÷30 (Art. T123/ER40) | Z091.002.R | RH |
| T118.988.R | HSK-63E | 76 | 63 | 63 | ∅ 4÷25 (Art. T135/ETS40) | Z091.302.R | RH |

COLLET CHUCKS HSK "E"

ART. T118

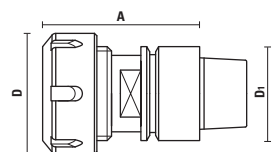

- Supplied with nut (without collet)
- Threaded nut and wrenches see page 7.31, spring collets see page 7.25, 7.27, 7.28
- Threaded nut DIN 6499
- **Balanced to 25.000 RPM at G 2,5**
- The "A" measure will be determined with clamped tool shanks by using our spring collet DIN6499. The "A" measure may be subject to variations depending on the diameter of the clamped tools
- The hollow taper shank is produced according to DIN69893 for inserting the Balluff microchip

| Item | Taper | A | D | D1 | Spring collets | Clamping nut | Rot. |
|--------------------------|---------|-----|----|----|-------------------------|-----------------|------|
| T118.990.R *1 NEW | HSK-25E | 40 | 22 | 25 | ∅ 2÷10 (Art. T127/ER16) | Z091.405.R Mini | RH |
| T118.991.R NEW | HSK-32E | 60 | 35 | 32 | ∅ 1÷13 (Art. T126/ER20) | Z091.104.R | RH |
| T118.992.R *1 NEW | HSK-32E | 60 | 42 | 32 | ∅ 2÷16 (Art. T125/ER25) | Z091.103.R | RH |
| T118.993.R *2 NEW | HSK-40E | 70 | 35 | 40 | ∅ 2÷16 (Art. T125/ER25) | Z091.403.R Mini | RH |
| T118.997.R NEW | HSK-50E | 80 | 42 | 50 | ∅ 2÷16 (Art. T125/ER25) | Z091.103.R | RH |
| T118.998.R NEW | HSK-50E | 100 | 50 | 50 | ∅ 2÷20 (Art. T119/ER32) | Z091.001.R | RH |

* Balanced to 40.000 RPM at G2,5 for "Multicam" machines
 * Balanced to 34.000 RPM at G2,5

COLLET CHUCKS HSK-50E 40

ART. T118

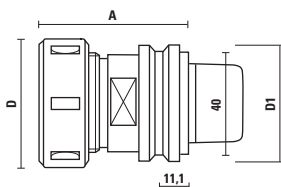

- Supplied with nut (without collet)
- Threaded nut and wrenches see page 7.31, spring collets see page 7.27
- Threaded nut DIN 6388 (EOC25)
- The "A" measure will be determined with clamped tool shanks by using our spring collet DIN 6388 (EOC25). The "A" measure may be subject to variations depending on the diameter of the clamped tools
- The hollow taper shank is produced according to DIN69893 for inserting the Balluff microchip

- For **ALBERTI "Polar"**

| Item | A | D | D1 | Spring collets | Clamping nut | Rot. |
|------------|----|----|----|--------------------------|-----------------------------|-------|
| T118.996.R | 75 | 60 | 50 | ∅ 2÷26 (Art. T124/EOC25) | Z091.203.R ball bearing nut | RH/LH |

COLLET CHUCKS ISO 30 FOR MULTIAX

ART. T118

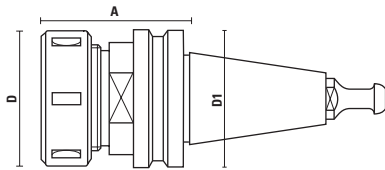

- Supplied with nut (without collet) and retaining pawl
- The "A" measure will be determined with clamped tool shanks by using our spring collet
The "A" measure may be subject to variations depending on the diameter of the clamped tools
- To be used with our spring collets with 3° taper angle only (see item T133 at page 7.29)
- **Special micro-shot peening treatment**

- Retaining pawl T118.891.R for: **Biesse, Masterwood, Multiax, Vitap**

| Item | Taper | A | D | D1 | Spring collets | Clamping nut | Rot. |
|-----------------------|--------|----|----|----|----------------|--------------|------|
| T118.841.R NEW | ISO 30 | 58 | 50 | 50 | ∅ 3÷25,4 | Z091.005.R | RH |

COLLET CHUCKS HSK-63F FOR MULTIAX

ART. T118

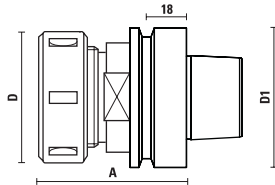
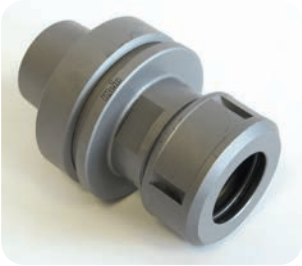

- Supplied with nut (without collet) and retaining pawl
- The "A" measure will be determined with clamped tool shanks by using our spring collet
The "A" measure may be subject to variations depending on the diameter of the clamped tools
- To be used with our spring collets with 3° taper angle only (see item T133 at page 7.29)
- **Special micro-shot peening treatment**

For: **Multiax**

| Item | Taper | A | D | D1 | Spring collets | Clamping nut | Rot. |
|-----------------------|---------|----|----|----|----------------|--------------|------|
| T118.941.R NEW | HSK 63F | 58 | 50 | 63 | ∅ 3÷25,4 | Z091.005.R | RH |
| T118.941.L NEW | HSK-63F | 58 | 50 | 63 | ∅ 3÷25,4 | Z091.005.R | LH |

DUST PLUG

ART. Z051

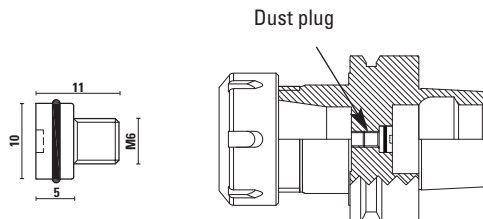

- To be used with our HSK toolholders to avoid any contamination of dust into the electrospindle.
- Inexpensive and easy to use.

| Item | Description |
|-----------------------|-------------|
| Z051.070.N NEW | M6x6 |

COLLET CHUCKS DIN 6499 (ER32)

ART. T118

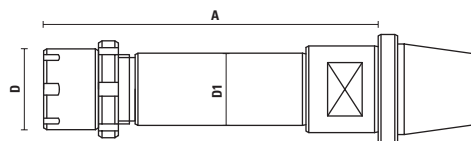

- Supplied with ER20 Mini nut and return ring nut (without spring collet)
- The "A" measure will be determined with clamped tool shanks by using our spring collet DIN 6499. The "A" measure may be subject to variations depending on the diameter of the clamped tools

For: **Bacci/Greda**

| Item | A | D | D1 | Spring collets | Clamping nut | Return ring nut | Rot. |
|-----------------------|----|----|----|-------------------------|------------------------|-----------------|------|
| T118.935.R NEW | 85 | 28 | 25 | ∅ 2÷13 (Art. T126/ER20) | Z091.404.R (ER20 Mini) | Z091.904.R | RH |

COLLET CHUCKS HSK63F HIGH SPEED LOW NOISE KleinOVERLINE

The increasing use of 5-axis machines has enabled to step up the possible workings and with it the need to perform operations in tight and hard to reach spaces.

In order to meet these needs with the utmost precision and excellent finishes we offer a range of special HSK63F tool holders for collets **ER16, ER32** and **DIN6388/EOC25**, balanced at grade **G 2.5 at 36,000 RPM**.

Main features **KleinOVERLINE**

- ✓ - Accessibility
- ✓ - Balance
- ✓ - Rotation speed
- ✓ - Noiselessness
- ✓ - Extended length tool holders, reaching 200 mm.
- ✓ - G 2.5 balancing grade
- ✓ - 36.000 RPM
- ✓ - No-noise nuts, with ground contours

These nuts should be tightened with a torque wrench (our item Z052 see page 10.08) on a proper demount device (our item T139 see page 7.41), as shown in the pictures.

The toolholders are supplied with a special design nut, with no lengthwise cuts, suitable for machining at high speed. A remarkable noise decrease is also achieved.



Adjustable demount devices Art. T139 page 7.41



Insert the collet chuck in the demount devices



Tighten the nut using the torque wrench Art Z052 page 10.08

COLLET CHUCKS HSK-63F ER16 - G2.5 BALANCING

ART. TK118

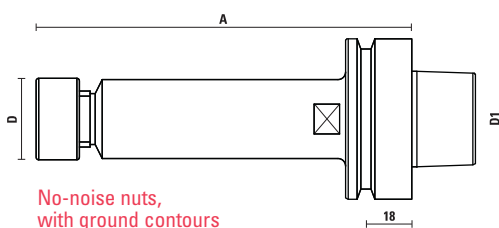

No-noise nuts, with ground contours

- Balanced at grade G 2.5 to 36.000 RPM
- Noise and vibrations reduction
- Supplied with nut (without collet)

- Threaded nut and wrenches see page 7.31, spring collets see page 7.28

- Threaded nut DIN 6499

- The "A" measure will be determined with clamped tool shanks by using our spring collet DIN6499. The "A" measure may be subject to variations depending on the diameter of the clamped tools.

On request can be supplied the standard clamping nuts (Items Z091 see pages 7.32, 10.13)

| Item | Taper | A | D | D1 | Spring collets | Clamping nut | Rot. |
|----------------|---------|-----|----|----|-------------------------|--------------|------|
| TK118.900.R150 | HSK-63F | 150 | 32 | 63 | Ø 2÷10 (Art. T127/ER16) | Z091.505.R | RH |

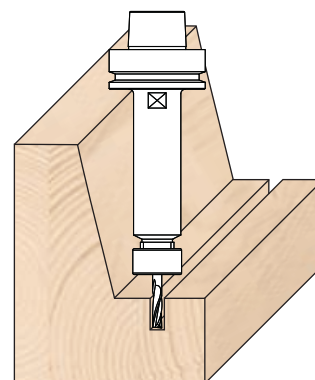
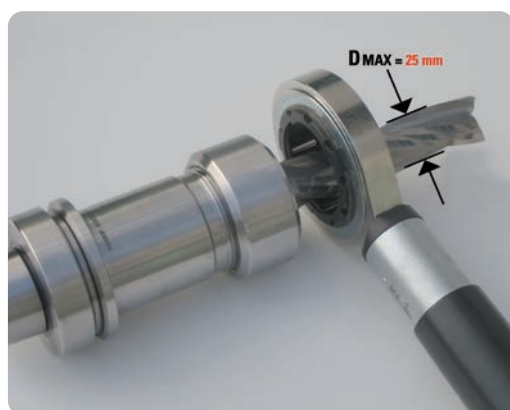

COLLET CHUCKS HSK-63F ER32 - G2.5 BALANCING

ART. TK118

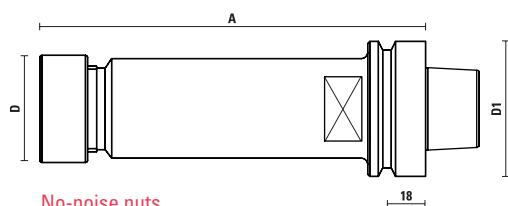

No-noise nuts,
with ground contours

- Balanced at grade G 2.5 to 36.000 RPM
- Noise and vibrations reduction
- Supplied with nut (without collet)
- Threaded nut and wrenches see page 7.31, spring collets see page 7.25
- Threaded nut DIN 6499
- The "A" measure will be determined with clamped tool shanks by using our spring collet DIN6499. The "A" measure may be subject to variations depending on the diameter of the clamped tools.

On request can be supplied the standard clamping nuts (Items Z091 see pages 7.32, 10.13)

| Item | Taper | A | D | D1 | Spring collets | Clamping nut | Rot. |
|----------------|---------|-----|----|----|-------------------------|--------------|------|
| TK118.976.R075 | HSK-63F | 75 | 50 | 63 | ∅ 2÷20 (Art. T119/ER32) | Z091.501.R | RH |
| TK118.976.R125 | HSK-63F | 125 | 50 | 63 | ∅ 2÷20 (Art. T119/ER32) | Z091.501.R | RH |
| TK118.976.R180 | HSK-63F | 180 | 50 | 63 | ∅ 2÷20 (Art. T119/ER32) | Z091.501.R | RH |

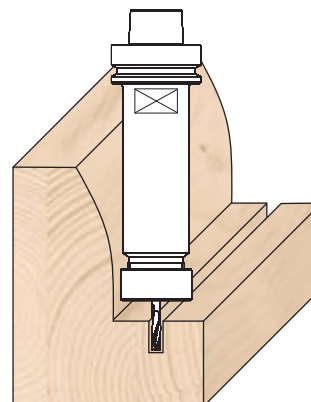
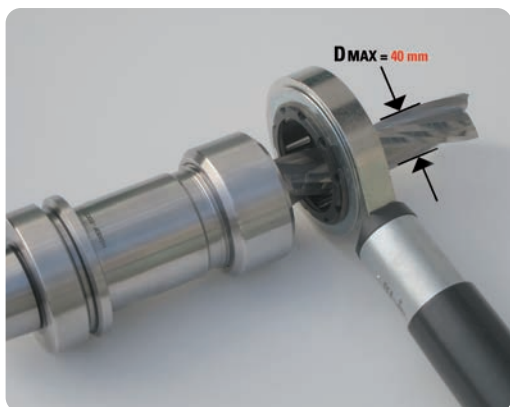

COLLET CHUCKS HSK-63F DIN6388/EOC25 - G2.5 BALANCING

ART. TK118

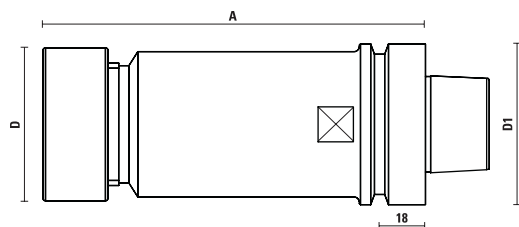

No-noise nuts,
with ground contours

- Balanced at grade G 2.5 to 36.000 RPM
- Noise and vibrations reduction
- Supplied with nut (without collet)
- Threaded nut and wrenches see page 7.31, spring collets see page 7.27
- Threaded nut DIN 6388 (EOC25)
- The "A" measure will be determined with clamped tool shanks by using our spring collet DIN6499. The "A" measure may be subject to variations depending on the diameter of the clamped tools.

On request can be supplied the standard clamping nuts (Items Z091 see pages 7.32, 10.13)

| Item | Taper | A | D | D1 | Spring collets | Clamping nut | Rot. |
|----------------|---------|-----|----|----|--------------------------|--------------|------|
| TK118.984.R078 | HSK-63F | 78 | 60 | 63 | ∅ 3÷26 (Art. T124/EOC25) | Z091.522.R | RH |
| TK118.984.R115 | HSK-63F | 115 | 60 | 63 | ∅ 3÷26 (Art. T124/EOC25) | Z091.522.R | RH |
| TK118.984.R150 | HSK-63F | 150 | 60 | 63 | ∅ 3÷26 (Art. T124/EOC25) | Z091.522.R | RH |
| TK118.984.R200 | HSK-63F | 200 | 60 | 63 | ∅ 3÷26 (Art. T124/EOC25) | Z091.522.R | RH |

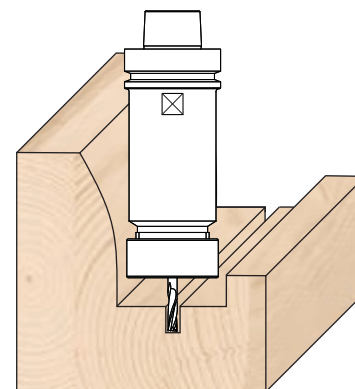
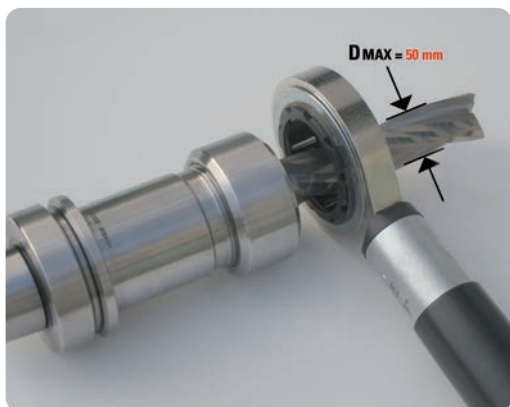

COLLET CHUCKS HSK-63F ER16 - G2.5 BALANCING

ART. TJ118

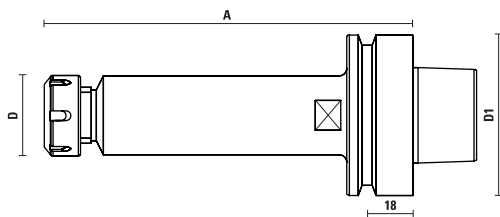

- **Balanced at G2.5**
- Maximum speed rotation at **36.000 RPM**
- Supplied with standard clamping nut
- Threaded nut and wrenches (see page 7.31)
- The "A" measure will be determined with clamped tool shanks by using our spring collet DIN6499.
- The "A" measure may be subject to variations depending on the diameter of the clamped tools.

| Item | Taper | A | D | D1 | Spring collets | Clamping nut | Rot. |
|---------------------------|---------|-----|----|----|-------------------------|--------------|------|
| TJ118.900.R150 NEW | HSK-63F | 150 | 32 | 63 | ∅ 2÷10 (Art. T127/ER16) | Z091.105.R | RH |

COLLET CHUCKS HSK-63F ER32 - G2.5 BALANCING

ART. TJ118

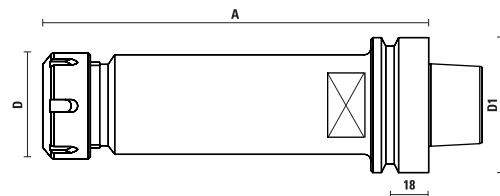

- **Balanced at G2.5**
- Maximum speed rotation at **36.000 RPM**
- Supplied with standard clamping nut
- Threaded nut and wrenches (see page 7.31)
- The "A" measure will be determined with clamped tool shanks by using our spring collet DIN6499.
- The "A" measure may be subject to variations depending on the diameter of the clamped tools.

| Item | Taper | A | D | D1 | Spring collets | Clamping nut | Rot. |
|---------------------------|---------|-----|----|----|-------------------------|--------------|------|
| TJ118.976.R075 NEW | HSK-63F | 75 | 50 | 63 | ∅ 2÷20 (Art. T119/ER32) | Z091.001.R | RH |
| TJ118.976.R125 NEW | HSK-63F | 125 | 50 | 63 | ∅ 2÷20 (Art. T119/ER32) | Z091.001.R | RH |
| TJ118.976.R180 NEW | HSK-63F | 180 | 50 | 63 | ∅ 2÷20 (Art. T119/ER32) | Z091.001.R | RH |

COLLET CHUCKS HSK-63F DIN6388/EOC25 - G2.5 BALANCING

ART. TJ118

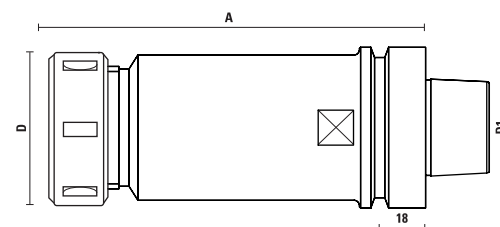

- **Balanced at G2.5**
- Maximum speed rotation at **36.000 RPM**
- Supplied with standard clamping nut
- Threaded nut and wrenches (see page 7.31)
- The "A" measure will be determined with clamped tool shanks by using our spring collet DIN6499.
- The "A" measure may be subject to variations depending on the diameter of the clamped tools.

| Item | Taper | A | D | D1 | Spring collets | Clamping nut | Rot. |
|---------------------------|---------|-----|----|----|--------------------------|--------------|------|
| TJ118.984.R078 NEW | HSK-63F | 78 | 60 | 63 | ∅ 3÷26 (Art. T124/EOC25) | Z091.202.R | RH |
| TJ118.984.R115 NEW | HSK-63F | 115 | 60 | 63 | ∅ 3÷26 (Art. T124/EOC25) | Z091.202.R | RH |
| TJ118.984.R150 NEW | HSK-63F | 150 | 60 | 63 | ∅ 3÷26 (Art. T124/EOC25) | Z091.202.R | RH |
| TJ118.984.R200 NEW | HSK-63F | 200 | 60 | 63 | ∅ 3÷26 (Art. T124/EOC25) | Z091.202.R | RH |

SHRINK FIT CHUCKS HSK-63F

ART. T120



HotBlock®

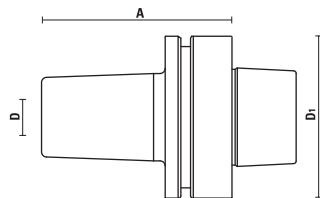

- **Concentricity** $\leq 0,003$ mm
- **High precision** tool holders guaranteed by thermally induced shrink fit
- High rigidity and balance for heavy CNC working
- For HS and HW cutting tool
- **Balanced to 24.000 RPM at G 2,5**
- **Right and left-hand rotation**
- Cutting tool shank must have tolerance h6 with cylindrical shank (no flats)

| Item | Taper | A | D1 | D | Rot. |
|-----------------------|---------|----|----|-------------------|-------|
| T120.580.N NEW | HSK-63F | 76 | 63 | 8 | RH/LH |
| T120.600.N NEW | HSK-63F | 76 | 63 | 10 | RH/LH |
| T120.620.N NEW | HSK-63F | 76 | 63 | 12 | RH/LH |
| T120.627.N NEW | HSK-63F | 76 | 63 | 1/2" - (12,7 mm) | RH/LH |
| T120.660.N NEW | HSK-63F | 76 | 63 | 16 | RH/LH |
| T120.695.N NEW | HSK-63F | 76 | 63 | 3/4" - (19,05 mm) | RH/LH |
| T120.700.N NEW | HSK-63F | 76 | 63 | 20 | RH/LH |
| T120.750.N NEW | HSK-63F | 76 | 63 | 25 | RH/LH |

HotBlock®: high precision tool holders which ensure more precision having less coupling thanks to its special tight on the shank tool by thermal clamping. First, the collet tip is heated with the special shrink fit unit (see our article K.START.2), causing it to expand. The cutter shank is then inserted, and the collet is cooled to ambient temperature with the cooling machine (see our article K.FG500). This causes the collet to contract precisely around the cutter shank with a special concentricity less than 3 micron, therefore the highest precision and stability for high performance.

SHRINK FIT UNIT

ART. K.START.2



- **Heating time from 2 to 7 seconds**
- Provided with inductor stop rings (6 to 12) + (14 to 20) and chuck holder for HSK63F
- Heating located on the tool holder, no deterioration of the tool and tool holder
- **Self-regulated power** thanks to a microprocessor depending on parameters detected
- **Inductor rotates 180°** without disassembling
- Power supply 3x380/480V – 16A 50/60 Hz -14 kW
- Dimensions: L= 255 mm - D= 490 mm - H= 755 mm
- Weight (options excluded) 20 kgs

See this product at Section 16, page 16.18.

Item

K.START.2 **NEW**

COOLING UNIT WITH AIR FLOW

ART. K.FG500



- Air cooling unit for shrink fit chucks
- **Cooling time from 1,30 minute to 3 minutes**
- Provided with cooling stop rings (6 to 12) + (14 to 20) and chuck holder for HSK63F
- Compressed air supply: 4-6 bars
- Dimensions: L= 220 mm - D= 190 mm - H= 615 mm
- Weight: 5 kgs

See this product at Section 16, page 16.18.

Item

K.FG500 **NEW**

NB: This items cannot be sold in Germany/France/USA due to commercial agreements between the producer (Elco) and their autorised dealers in these markets.

SHRINK FIT CHUCK EXTENSIONS L=150

ART. T120

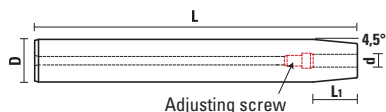

- Suitable for **working deep and hard to reach surfaces**
- To be used with heat shrink fit chucks (our item T120) or hydro chuck
- Best results when clamping HW or HS tools with h6 tool shank
- **With adjusting screw for length adjustment**

| Item | D | d | L | L1 | Screw |
|------------------------|----|----|-----|----|-------|
| T120.012.03 NEW | 12 | 3 | 150 | 12 | M5 |
| T120.012.04 NEW | 12 | 4 | 150 | 16 | M5 |
| T120.016.04 NEW | 16 | 4 | 150 | 16 | M5 |
| T120.016.06 NEW | 16 | 6 | 150 | 26 | M5 |
| T120.020.06 NEW | 20 | 6 | 150 | 26 | M5 |
| T120.020.08 NEW | 20 | 8 | 150 | 26 | M6 |
| T120.020.10 NEW | 20 | 10 | 150 | 32 | M6 |
| T120.020.12 NEW | 20 | 12 | 150 | 37 | M10 |
| T120.025.08 NEW | 25 | 8 | 150 | 26 | M6 |
| T120.025.10 NEW | 25 | 10 | 150 | 32 | M6 |
| T120.025.12 NEW | 25 | 12 | 150 | 37 | M10 |
| T120.025.16 NEW | 25 | 16 | 150 | 40 | M10 |

STRAIGHT SHANK TOOL EXTENSION

ART. T121

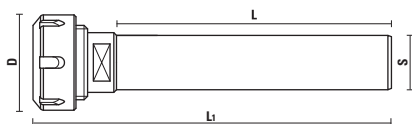

- To be used on ER tool holders
- Suitable for **working deep and hard to reach surfaces**

| Item | D | Spring collets | Clamping nut | S | L | L1 | Rot. |
|-----------------------------|----|-------------------------|-----------------|----|-----|-----|------|
| T121.016.120.080 NEW | 22 | Ø 2÷10 (Art. T127/ER16) | Z091.405.R Mini | 12 | 80 | 118 | RH |
| T121.016.160.100 NEW | 22 | Ø 2÷10 (Art. T127/ER16) | Z091.405.R Mini | 16 | 100 | 138 | RH |
| T121.016.200.100 NEW | 22 | Ø 2÷10 (Art. T127/ER16) | Z091.405.R Mini | 20 | 100 | 131 | RH |
| T121.016.200.160 NEW | 22 | Ø 2÷10 (Art. T127/ER16) | Z091.405.R Mini | 20 | 160 | 191 | RH |
| T121.016.200.200 NEW | 22 | Ø 2÷10 (Art. T127/ER16) | Z091.405.R Mini | 20 | 200 | 231 | RH |
| T121.020.160.100 NEW | 28 | Ø 2÷13 (Art. T126/ER20) | Z091.404.R Mini | 16 | 100 | 142 | RH |
| T121.020.160.160 NEW | 28 | Ø 2÷13 (Art. T126/ER20) | Z091.404.R Mini | 16 | 160 | 202 | RH |
| T121.020.200.100 NEW | 28 | Ø 2÷13 (Art. T126/ER20) | Z091.404.R Mini | 20 | 100 | 137 | RH |
| T121.020.200.160 NEW | 28 | Ø 2÷13 (Art. T126/ER20) | Z091.404.R Mini | 20 | 160 | 197 | RH |
| T121.020.250.160 NEW | 28 | Ø 2÷13 (Art. T126/ER20) | Z091.404.R Mini | 25 | 160 | 188 | RH |
| T121.020.250.240 NEW | 28 | Ø 2÷13 (Art. T126/ER20) | Z091.404.R Mini | 25 | 240 | 282 | RH |
| T121.025.200.060 NEW | 35 | Ø 3÷16 (Art. T125/ER25) | Z091.403.R Mini | 20 | 60 | 106 | RH |
| T121.025.200.100 NEW | 35 | Ø 3÷16 (Art. T125/ER25) | Z091.403.R Mini | 20 | 100 | 146 | RH |
| T121.025.200.160 NEW | 35 | Ø 3÷16 (Art. T125/ER25) | Z091.403.R Mini | 20 | 160 | 206 | RH |
| T121.025.250.100 NEW | 42 | Ø 3÷16 (Art. T125/ER25) | Z091.103.R | 25 | 100 | 140 | RH |
| T121.025.250.160 NEW | 42 | Ø 3÷16 (Art. T125/ER25) | Z091.103.R | 25 | 160 | 200 | RH |

Example of use:

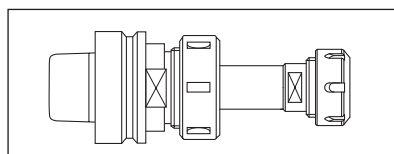

- For a proper use and maximum holding power, fill the collet all the way with the extension shank;
- It is very important to tighten the collet nut of tool holder to recommended torque using a torque wrench;
- When the extension is mounted, balancing grade is not guaranteed.

STAINLESS STEEL COLLET CHUCKS

Useful information:

- Solid stainless steel collet chucks are **more resistant** and have a **longer life span**;
- A special surface treatment guarantees an **excellent resistance to corrosion** and an **aesthetic pleasing**;
- **No problems of peeling** compared to coated chucks.
- **Better working performances** and longer life of the electrospindles.

COLLET CHUCKS ISO 30 INOX

ART. T118



- The "A" measure will be determined with clamped tool shanks by using our spring collet DIN6499. The "A" measure may be subject to variations depending on the diameter of the clamped tools.

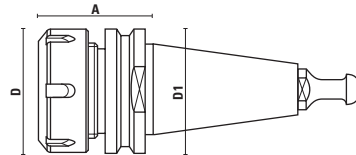

- **Produced in stainless steel AISI 420**

- Supplied with nut (without collet) and retaining pawl;
- Needed when working with coolant: machines for marble, glass, aluminium working and others;
- Highly recommended when processing resinoid wood and composite materials;
- Suggested when working in "**humid**" environment;
- Extremely **low maintenance costs**, easy to clean;
- When used with coolant our water-tight spring collets are suggested (see page 7.26)

Retaining pawl T118.891.R For: **Biesse** (after 09/09/92), **Masterwood - Bulleri** (motor H.S.D.), **Vitap**

| Item | Taper | A | D | D1 | Spring collets | Clamping nut | Rot. |
|--------------|--------|----|----|----|-------------------------|-----------------------------|-------|
| T118.800.RAI | ISO 30 | 50 | 50 | 50 | ∅ 2÷20 (Art. T119/ER32) | Z091.001.R | RH |
| T118.802.RAI | ISO 30 | 50 | 50 | 50 | ∅ 2÷20 (Art. T119/ER32) | Z091.101.R ball bearing nut | RH/LH |
| T118.830.RAI | ISO 30 | 55 | 63 | 50 | ∅ 2÷30 (Art. T123/ER40) | Z091.002.R | RH |
| T118.832.RAI | ISO 30 | 55 | 63 | 50 | ∅ 2÷30 (Art. T123/ER40) | Z091.102.R ball bearing nut | RH/LH |

Retaining pawl T118.792.R For: **Alberti, Vitap, Masterwood** (motor G. Colombo)

| Item | Taper | A | D | D1 | Spring collets | Clamping nut | Rot. |
|--------------|--------|----|----|----|-------------------------|-----------------------------|-------|
| T118.811.RAI | ISO 30 | 50 | 50 | 50 | ∅ 2÷20 (Art. T119/ER32) | Z091.001.R | RH |
| T118.813.RAI | ISO 30 | 50 | 50 | 50 | ∅ 2÷20 (Art. T119/ER32) | Z091.101.R ball bearing nut | RH/LH |
| T118.815.RAI | ISO 30 | 55 | 63 | 50 | ∅ 2÷30 (Art. T123/ER40) | Z091.002.R | RH |
| T118.817.RAI | ISO 30 | 55 | 63 | 50 | ∅ 2÷30 (Art. T123/ER40) | Z091.102.R ball bearing nut | RH/LH |

Retaining pawl T118.791.R (DIN 69872) For: **Anderson, Busellato, Weeke, Ima, Bulleri, Maka, Cosmec, Reichenbacher, Elte**

| Item | Taper | A | D | D1 | Spring collets | Clamping nut | Rot. |
|--------------|--------|----|----|----|-------------------------|-----------------------------|-------|
| T118.821.RAI | ISO 30 | 50 | 50 | 50 | ∅ 2÷20 (Art. T119/ER32) | Z091.001.R | RH |
| T118.823.RAI | ISO 30 | 50 | 50 | 50 | ∅ 2÷20 (Art. T119/ER32) | Z091.101.R ball bearing nut | RH/LH |
| T118.825.RAI | ISO 30 | 55 | 63 | 50 | ∅ 2÷30 (Art. T123/ER40) | Z091.002.R | RH |
| T118.827.RAI | ISO 30 | 55 | 63 | 50 | ∅ 2÷30 (Art. T123/ER40) | Z091.102.R ball bearing nut | RH/LH |

COLLET CHUCKS HSK-63F INOX

ART. T118



- The "A" measure will be determined with clamped tool shanks by using our spring collet DIN6499. The "A" measure may be subject to variations depending on the diameter of the clamped tools.

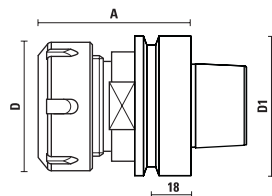

- **Produced in stainless steel AISI 420**

- Supplied with nut (without collet) and retaining pawl;
- Needed when working with coolant: machines for marble, glass, aluminium working and others;
- Highly recommended when processing resinoid wood and composite materials;
- Suggested when working in "**humid**" environment;
- Extremely **low maintenance costs**, easy to clean;
- When used with coolant our water-tight spring collets are suggested (see page 7.26)

| Item | Taper | A | D | D1 | Spring collets | Clamping nut | Rot. |
|--------------|---------|----|----|----|--------------------------|-----------------------------|-------|
| T118.976.RAI | HSK-63F | 74 | 50 | 63 | ∅ 2÷20 (Art. T119/ER32) | Z091.001.R | RH |
| T118.978.RAI | HSK-63F | 74 | 50 | 63 | ∅ 2÷20 (Art. T119/ER32) | Z091.101.R ball bearing nut | RH/LH |
| T118.980.RAI | HSK-63F | 77 | 63 | 63 | ∅ 2÷30 (Art. T123/ER40) | Z091.002.R | RH |
| T118.982.RAI | HSK-63F | 77 | 63 | 63 | ∅ 2÷30 (Art. T123/ER40) | Z091.102.R ball bearing nut | RH/LH |
| T118.983.RAI | HSK-63F | 78 | 60 | 63 | ∅ 3÷26 (Art. T124/E0C25) | Z091.202.R | RH |
| T118.984.RAI | HSK-63F | 78 | 60 | 63 | ∅ 3÷26 (Art. T124/E0C25) | Z091.203.R ball bearing nut | RH/LH |

SPRING COLLETS

HOW TO INSERT THE SPRING COLLET IN THE NUT

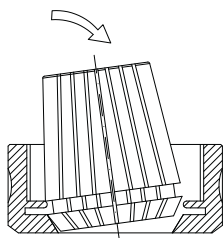

Right procedure to assemble the collet in the nut:

- place the collet diagonal to the clamping nut and lock it from the side by pressing it from top
- screw the nut and be sure the shank is correctly inserted in the spring collet.

Tighten the nut using the apposite key on the proper demount device (Art. T139, see page 7.41)

Do not place the spring collet in the collet chuck before you have it properly inserted in the nut.

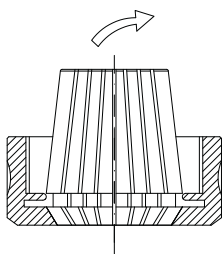

Correct procedure for tool and spring collet change:

- place the collet chuck in the mounting device
- untighten the clamping nut
- open the clamping nut and pull the cutting tool out holding it on the shank
- release the collet from the clamping nut by lateral pressure

Klein OFFERS ONLY HIGH PRECISION SPRING COLLETS:

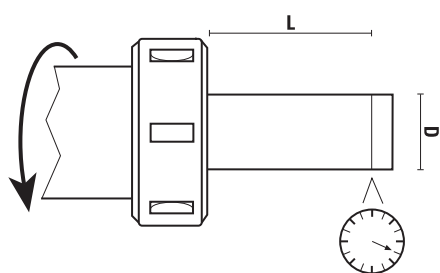

| D | L | Standard Precision | High Precision Klein |
|--------------|----|--------------------|--------------------------------|
| Ø3 - Ø4 - Ø5 | 16 | 0,015 | > 0,010 |
| Ø6 ÷ Ø9,5 | 25 | 0,015 | > 0,010 |
| Ø10 ÷ Ø17 | 40 | 0,020 | > 0,010 |
| Ø18 ÷ Ø26 | 50 | 0,020 | > 0,010 |

Using high precision spring collets, vibrations on the tools and motors are reduced, assuring better results and a longer life of the tools and electrospindles.

COLLET LIFE SPAN:

Spring collets have a life span of approximately 3 months if used 8 hours a day.

Replacing the collets will ensure your operation runs consistency and prevents from tool breakage.

MAINTENANCE:

Keeping spring collets and tools clean is essential for a longer life.

The worked material produces chips and dirt which can cause an elliptical tool rotation.

The seats of collet chucks and electrospindles should be cleaned daily with the correct tapers (see our items **T137** and **X137** at the page 7.40)



SPRING COLLETS ER 32 - DIN 6499

ART. T119

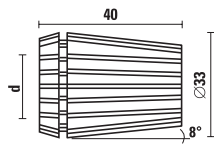

Precision= 0,01

| Item | d |
|------------|---------------|
| T119.020.N | Ø 2 - 1 |
| T119.030.N | Ø 3 - 2 |
| T119.032.N | Ø 3,2 (1/8") |
| T119.040.N | Ø 4 - 3 |
| T119.048.N | Ø 4,8 (3/16") |
| T119.050.N | Ø 5 - 4 |
| T119.060.N | Ø 6 - 5 |
| T119.064.N | Ø 6,4 (1/4") |
| T119.070.N | Ø 7 - 6 |
| T119.079.N | Ø 7,9 (5/16") |
| T119.080.N | Ø 8 - 7 |
| T119.090.N | Ø 9 - 8 |
| T119.095.N | Ø 9,5 (3/8") |
| T119.100.N | Ø 10 - 9 |
| T119.110.N | Ø 11 - 10 |
| T119.120.N | Ø 12 - 11 |
| T119.127.N | Ø 12,7 (1/2") |
| T119.130.N | Ø 13 - 12 |
| T119.140.N | Ø 14 - 13 |
| T119.150.N | Ø 15 - 14 |
| T119.159.N | Ø 15,9 (5/8") |
| T119.160.N | Ø 16 - 15 |
| T119.170.N | Ø 17 - 16 |
| T119.180.N | Ø 18 - 17 |
| T119.190.N | Ø 19 - 18 |
| T119.191.N | Ø 19,1 (3/4") |
| T119.200.N | Ø 20 - 19 |

SPRING COLLET SET ER 32 - DIN 6499

ART. X119



- Complete with 18 pcs
- In carton Box

| Item | Diameters: |
|------------|-----------------------------------|
| X119.118.N | Ø3 - Ø4 - Ø5 - Ø6 - Ø7 - Ø8 |
| | Ø9 - Ø10 - Ø11 - Ø12 - Ø13 - Ø14 |
| | Ø15 - Ø16 - Ø17 - Ø18 - Ø19 - Ø20 |

SPRING COLLETS ER 40 - DIN 6499

ART. T123

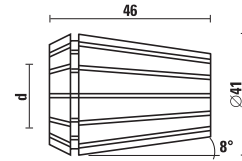

Precision= 0,01

| Item | d |
|------------|---------------|
| T123.030.N | Ø 3 - 2 |
| T123.032.N | Ø 3,2 (1/8") |
| T123.040.N | Ø 4 - 3 |
| T123.048.N | Ø 4,8 (3/16") |
| T123.050.N | Ø 5 - 4 |
| T123.060.N | Ø 6 - 5 |
| T123.064.N | Ø 6,4 (1/4") |
| T123.070.N | Ø 7 - 6 |
| T123.079.N | Ø 7,9 (5/16") |
| T123.080.N | Ø 8 - 7 |
| T123.090.N | Ø 9 - 8 |
| T123.095.N | Ø 9,5 (3/8") |
| T123.100.N | Ø 10 - 9 |
| T123.110.N | Ø 11 - 10 |
| T123.120.N | Ø 12 - 11 |
| T123.127.N | Ø 12,7 (1/2") |
| T123.130.N | Ø 13 - 12 |
| T123.140.N | Ø 14 - 13 |
| T123.150.N | Ø 15 - 14 |
| T123.159.N | Ø 15,9 (5/8") |
| T123.160.N | Ø 16 - 15 |
| T123.170.N | Ø 17 - 16 |
| T123.180.N | Ø 18 - 17 |
| T123.190.N | Ø 19 - 18 |
| T123.191.N | Ø 19,1 (3/4") |
| T123.200.N | Ø 20 - 19 |
| T123.210.N | Ø 21 - 20 |
| T123.220.N | Ø 22 - 21 |
| T123.230.N | Ø 23 - 22 |
| T123.240.N | Ø 24 - 23 |
| T123.250.N | Ø 25 - 24 |
| T123.254.N | Ø 25,4 (1") |
| T123.260.N | Ø 26 - 25 |
| T123.300.N | Ø 30 - 29 |

SPRING COLLET SET ER 40 - DIN 6499

ART. X123



- Complete with 23 pcs
- In carton Box

| Item | Diameters: |
|------------|-----------------------------------|
| X123.023.N | Ø3 - Ø4 - Ø5 - Ø6 - Ø7 - Ø8 |
| | Ø9 - Ø10 - Ø11 - Ø12 - Ø13 - Ø14 |
| | Ø15 - Ø16 - Ø17 - Ø18 - Ø19 - Ø20 |
| | Ø21 - Ø22 - Ø23 - Ø24 - Ø25 |

WATER-TIGHT SPRING COLLETS ER 32 - DIN 6499

ART. T119

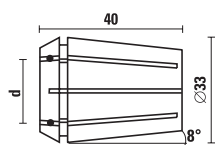

- Precision= 0,01
- Highly recommended when working with lubricant
- Indicated for working aluminium, marble, glass and others
- To be used only with our clamping nuts with eccentric ring (item Z091.051.R)

| Item | d |
|--------------|-----------|
| T119.020.NTS | Ø 2 - 1 |
| T119.030.NTS | Ø 3 - 2 |
| T119.040.NTS | Ø 4 - 3 |
| T119.050.NTS | Ø 5 - 4 |
| T119.060.NTS | Ø 6 - 5 |
| T119.070.NTS | Ø 7 - 6 |
| T119.080.NTS | Ø 8 - 7 |
| T119.090.NTS | Ø 9 - 8 |
| T119.100.NTS | Ø 10 - 9 |
| T119.110.NTS | Ø 11 - 10 |
| T119.120.NTS | Ø 12 - 11 |
| T119.130.NTS | Ø 13 - 12 |
| T119.140.NTS | Ø 14 - 13 |
| T119.150.NTS | Ø 15 - 14 |
| T119.160.NTS | Ø 16 - 15 |
| T119.170.NTS | Ø 17 - 16 |
| T119.180.NTS | Ø 18 - 17 |
| T119.190.NTS | Ø 19 - 18 |
| T119.200.NTS | Ø 20 - 19 |

WATER-TIGHT SPRING COLLET SET ER 32 - DIN 6499

ART. X119



- Complete with 18 pcs
- In carton Box

| Item | Diameters: |
|--------------|--|
| X119.118.NTS | Ø3 - Ø4 - Ø5 - Ø6 - Ø7 - Ø8 Ø9 - Ø10 - Ø11 - Ø12 - Ø13 - Ø14 Ø15 - Ø16 - Ø17 - Ø18 - Ø19 - Ø20 |

WATER-TIGHT SPRING COLLETS ER 40 - DIN 6499

ART. T123

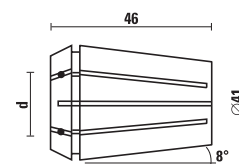

- Precision= 0,01
- Highly recommended when working with lubricant
- Indicated for working aluminium, marble, glass and others
- To be used only with our clamping nuts with eccentric ring (item Z091.051.R)

| Item | d |
|--------------|--------------|
| T123.030.NTS | Ø 3 - 2 |
| T123.032.NTS | Ø 3,2 (1/8") |
| T123.040.NTS | Ø 4 - 3 |
| T123.050.NTS | Ø 5 - 4 |
| T123.060.NTS | Ø 6 - 5 |
| T123.070.NTS | Ø 7 - 6 |
| T123.080.NTS | Ø 8 - 7 |
| T123.090.NTS | Ø 9 - 8 |
| T123.100.NTS | Ø 10 - 9 |
| T123.110.NTS | Ø 11 - 10 |
| T123.120.NTS | Ø 12 - 11 |
| T123.130.NTS | Ø 13 - 12 |
| T123.140.NTS | Ø 14 - 13 |
| T123.150.NTS | Ø 15 - 14 |
| T123.160.NTS | Ø 16 - 15 |
| T123.170.NTS | Ø 17 - 16 |
| T123.180.NTS | Ø 18 - 17 |
| T123.190.NTS | Ø 19 - 18 |
| T123.200.NTS | Ø 20 - 19 |
| T123.210.NTS | Ø 21 - 20 |
| T123.220.NTS | Ø 22 - 21 |
| T123.230.NTS | Ø 23 - 22 |
| T123.240.NTS | Ø 24 - 23 |
| T123.250.NTS | Ø 25 - 24 |
| T123.260.NTS | Ø 26 - 25 |

WATER-TIGHT SPRING COLLET SET ER 40 - DIN 6499

ART. X123



- Complete with 23 pcs
- In carton Box

| Item | Diameters: |
|--------------|---|
| X123.023.NTS | Ø3 - Ø4 - Ø5 - Ø6 - Ø7 - Ø8 Ø9 - Ø10 - Ø11 - Ø12 - Ø13 - Ø14 Ø15 - Ø16 - Ø17 - Ø18 - Ø19 - Ø20 Ø21 - Ø22 - Ø23 - Ø24 - Ø25 |

SPRING COLLETS EOC25 - DIN 6388 (462 E)

ART. T124

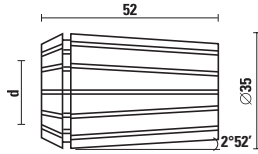

Precision= 0,01

| Item | d |
|-----------------------|---------------|
| T124.020.N | ∅ 2 - 1,5 |
| T124.030.N | ∅ 3 - 2,5 |
| T124.032.N NEW | ∅ 3,2 (1/8") |
| T124.040.N | ∅ 4 - 3,5 |
| T124.048.N NEW | ∅ 4,8 (3/16") |
| T124.050.N | ∅ 5 - 4,5 |
| T124.060.N | ∅ 6 - 5,5 |
| T124.064.N | ∅ 6,4 (1/4") |
| T124.070.N | ∅ 7 - 6,5 |
| T124.079.N | ∅ 7,9 (5/16") |
| T124.080.N | ∅ 8 - 7,5 |
| T124.095.N | ∅ 9,5 (3/8") |
| T124.100.N | ∅ 10 - 9,5 |
| T124.110.N | ∅ 11 - 10,5 |
| T124.120.N | ∅ 12 - 11,5 |
| T124.127.N | ∅ 12,7 (1/2") |
| T124.130.N | ∅ 13 - 12,5 |
| T124.140.N | ∅ 14 - 13,5 |
| T124.159.N | ∅ 15,9 (5/8") |
| T124.160.N | ∅ 16 - 15,5 |
| T124.180.N | ∅ 18 - 17,5 |
| T124.190.N | ∅ 19 - 18,5 |
| T124.191.N | ∅ 19,1 (3/4") |
| T124.200.N | ∅ 20 - 19,5 |
| T124.220.N | ∅ 22 - 21,5 |
| T124.250.N | ∅ 25 - 24,5 |
| T124.254.N | ∅ 25,4 (1") |

SPRING COLLETS ER 20 - DIN 6499

ART. T126

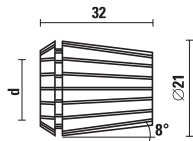

Precision= 0,01

| Item | d |
|------------|----------------|
| T126.016.N | ∅ 1,59 (1/16") |
| T126.030.N | ∅ 3 - 2 |
| T126.032.N | ∅ 3,2 (1/8") |
| T126.040.N | ∅ 4 - 3 |
| T126.050.N | ∅ 5 - 4 |
| T126.060.N | ∅ 6 - 5 |
| T126.064.N | ∅ 6,4 (1/4") |
| T126.070.N | ∅ 7 - 6 |
| T126.080.N | ∅ 8 - 7 |
| T126.090.N | ∅ 9 - 8 |
| T126.095.N | ∅ 9,5 (3/8") |
| T126.100.N | ∅ 10 - 9 |
| T126.110.N | ∅ 11 - 10 |
| T126.120.N | ∅ 12 - 11 |
| T126.127.N | ∅ 12,7 (1/2") |
| T126.130.N | ∅ 13 - 12 |

SPRING COLLETS ER 25 - DIN 6499

ART. T125

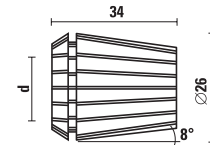

Precision= 0,01

| Item | d |
|------------|----------------|
| T125.016.N | ∅ 1,59 (1/16") |
| T125.020.N | ∅ 2 - 1 |
| T125.030.N | ∅ 3 - 2 |
| T125.032.N | ∅ 3,2 (1/8") |
| T125.040.N | ∅ 4 - 3 |
| T125.048.N | ∅ 4,8 (3/16") |
| T125.050.N | ∅ 5 - 4 |
| T125.060.N | ∅ 6 - 5 |
| T125.064.N | ∅ 6,4 (1/4") |
| T125.070.N | ∅ 7 - 6 |
| T125.079.N | ∅ 7,9 (5/16") |
| T125.080.N | ∅ 8 - 7 |
| T125.090.N | ∅ 9 - 8 |
| T125.095.N | ∅ 9,5 (3/8") |
| T125.100.N | ∅ 10 - 9 |
| T125.110.N | ∅ 11 - 10 |
| T125.120.N | ∅ 12 - 11 |
| T125.127.N | ∅ 12,7 (1/2") |
| T125.130.N | ∅ 13 - 12 |
| T125.140.N | ∅ 14 - 13 |
| T125.150.N | ∅ 15 - 14 |
| T125.159.N | ∅ 15,9 (5/8") |
| T125.160.N | ∅ 16 - 15 |

SPRING COLLET SET ER25 - DIN 6499

ART. X125



- Complete with 14 pcs
- In wooden Box

| Item | Diameters: |
|------------|---|
| X125.014.N | ∅3 - ∅4 - ∅5 - ∅6 - ∅7 - ∅8 - ∅9 ∅10 - ∅11 - ∅12 - ∅13 - ∅14 - ∅15 - ∅16 |

SPRING COLLETS ER 16 - DIN 6499

ART. T127

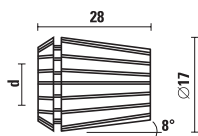

Precision= 0,01

| Item | d |
|------------|----------------|
| T127.016.N | Ø 1,59 (1/16") |
| T127.020.N | Ø 2 - 1 |
| T127.030.N | Ø 3 - 2 |
| T127.032.N | Ø 3,2 (1/8") |
| T127.040.N | Ø 4 - 3 |
| T127.050.N | Ø 5 - 4 |
| T127.060.N | Ø 6 - 5 |
| T127.064.N | Ø 6,4 (1/4") |
| T127.070.N | Ø 7 - 6 |
| T127.080.N | Ø 8 - 7 |
| T127.090.N | Ø 9 - 8 |
| T127.095.N | Ø 9,5 (3/8") |
| T127.100.N | Ø 10 - 9 |

SPRING COLLETS ER 11 - DIN 6499

ART. T129

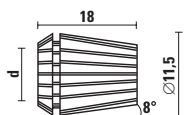

Precision= 0,01

| Articolo/Item | d |
|---------------|---------------|
| T129.010.N | Ø 1-0,5 |
| T129.015.N | Ø 1,5-1 |
| T129.020.N | Ø 2-1,5 |
| T129.025.N | Ø 2,5-2 |
| T129.030.N | Ø 3-2,5 |
| T129.032.N | Ø 3,2 (1/8") |
| T129.035.N | Ø 3,5-3 |
| T129.040.N | Ø 4-3,5 |
| T129.045.N | Ø 4,5-4 |
| T129.048.N | Ø 4,8 (3/16") |
| T129.050.N | Ø 5-4,5 |
| T129.055.N | Ø 5,5-5 |
| T129.060.N | Ø 6-5,5 |
| T129.064.N | Ø 6,4 (1/4") |
| T129.065.N | Ø 6,5-6 |
| T129.070.N | Ø 7-6,5 |

SPRING COLLETS ETS 32 - DIN 6499

ART. T134

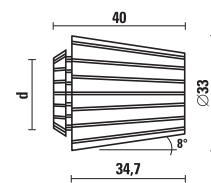

Precision= 0,01

| Item | d |
|------------|-----------|
| T134.030.N | Ø 3 - 2 |
| T134.040.N | Ø 4 - 3 |
| T134.050.N | Ø 5 - 4 |
| T134.060.N | Ø 6 - 5 |
| T134.070.N | Ø 7 - 6 |
| T134.080.N | Ø 8 - 7 |
| T134.100.N | Ø 10 - 9 |
| T134.120.N | Ø 12 - 11 |
| T134.130.N | Ø 13 - 12 |
| T134.140.N | Ø 14 - 13 |
| T134.160.N | Ø 16 - 15 |
| T134.180.N | Ø 18 - 17 |
| T134.200.N | Ø 20 - 19 |

SPRING COLLETS ETS 40 - DIN 6499

ART. T135

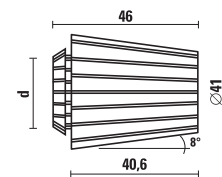
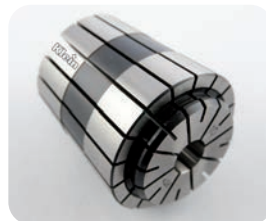

Precision= 0,01

| Item | d |
|------------|-----------|
| T135.040.N | Ø 4 - 3 |
| T135.050.N | Ø 5 - 4 |
| T135.060.N | Ø 6 - 5 |
| T135.070.N | Ø 7 - 6 |
| T135.080.N | Ø 8 - 7 |
| T135.100.N | Ø 10 - 9 |
| T135.120.N | Ø 12 - 11 |
| T135.130.N | Ø 13 - 12 |
| T135.140.N | Ø 14 - 13 |
| T135.160.N | Ø 16 - 15 |
| T135.180.N | Ø 18 - 17 |
| T135.200.N | Ø 20 - 19 |
| T135.250.N | Ø 25 - 24 |

SPRING COLLETS EOC12 - DIN 6388 (407E)

ART. T136

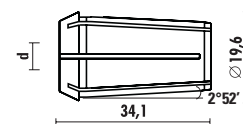

- To be used with Art. T118.580.R
- Precision= 0,01

| Item | d |
|------------|---------------|
| T136.040.N | Ø 4 - 3 |
| T136.060.N | Ø 6 - 5 |
| T136.064.N | Ø 6,4 (1/4") |
| T136.080.N | Ø 8 - 7 |
| T136.095.N | Ø 9,5 (3/8") |
| T136.100.N | Ø 10 - 9 |
| T136.120.N | Ø 12 - 11 |
| T136.127.N | Ø 12,7 (1/2") |

SPRING COLLETS EOC16 - DIN 6388 (415E)

ART. T138

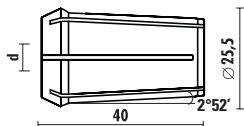

- Precision= 0,01

| Item | d |
|------------|---------------|
| T138.040.N | ∅ 4 - 3 |
| T138.060.N | ∅ 6 - 5 |
| T138.064.N | ∅ 6,4 (1/4") |
| T138.080.N | ∅ 8 - 7 |
| T138.095.N | ∅ 9,5 (3/8") |
| T138.100.N | ∅ 10 - 9 |
| T138.120.N | ∅ 12 - 11 |
| T138.127.N | ∅ 12,7 (1/2") |

SPRING COLLETS 3° TAPER ANGLE

ART. T133

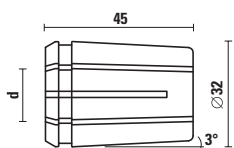

To be used with our tool holders (see item T118.941.R and T118.841.R) for Multiax router machines only.

Precision= 0,01

| Item | d |
|-----------------------|---------------|
| T133.032.N NEW | ∅ 3,2 (1/8") |
| T133.040.N NEW | ∅ 4 - 3 |
| T133.060.N NEW | ∅ 6 - 5 |
| T133.064.N NEW | ∅ 6,4 (1/4") |
| T133.079.N NEW | ∅ 7,9 (5/16") |
| T133.080.N NEW | ∅ 8 - 7 |
| T133.095.N NEW | ∅ 9,5 (3/8") |
| T133.100.N NEW | ∅ 10 - 9 |
| T133.120.N NEW | ∅ 12 - 11 |
| T133.127.N NEW | ∅ 12,7 (1/2") |
| T133.159.N NEW | ∅ 15,9 (5/8") |
| T133.160.N NEW | ∅ 16 - 15 |
| T133.191.N NEW | ∅ 19,1 (3/4") |
| T133.200.N NEW | ∅ 20 - 19 |
| T133.250.N NEW | ∅ 25 - 24 |
| T133.254.N NEW | ∅ 25,4 (1") |



SPRING COLLET SET + WIPE OFF KIT





The **wipe off set** allows maintaining the inside as well as the seat of the spring collet on the chuck clean, helps increasing cutting efficiency and reduce vibrations for a longer tool life. No more risk of wrong positioning of both the collet and the tool due to chips and resin.

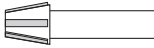
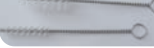

- In plastic box

Set complete with:
 - nr. 10 spring collets
 - Collet wipers
 - Brushes for collet bore

| Item | |
|---|---|
|  X125.515.N | |
| | Set complete with 10 spring collets ER25: ∅3 - ∅4 - ∅5 - ∅6 - ∅7 ∅8 - ∅10 - ∅12 - ∅14 - ∅16 |
|  T137.525.N - Collet wiper ER25 | |
|  X137.004.N - nr. 4 brushes for collet bore ER25 | |

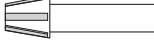
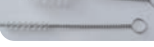
| Item | |
|---|---|
|  X119.515.N | |
| | Set complete with 10 spring collets ER32: ∅4 - ∅5 - ∅6 - ∅8 - ∅10 - ∅12 - ∅14 - ∅16 - ∅18 - ∅20 |
|  T137.532N - Collet wiper ER32 | |
|  X137.004.N - nr. 4 brushes for collet bore ER32 | |

| Item | |
|---|--|
|  X123.515.N | |
| | Set complete with 10 spring collets ER40: ∅4 - ∅6 - ∅8 - ∅10 - ∅12 - ∅14 - ∅16 - ∅18 - ∅20 - ∅25 |
|  T137.540N - Collet wiper ER40 | |
|  X137.004.N - nr. 4 brushes for collet bore ER40 | |

| Item | |
|--|---|
|  X124.515.N | |
| | Set complete with 10 spring collets DIN6388: ∅4 - ∅6 - ∅8 - ∅10 - ∅12 - ∅14 - ∅16 - ∅18 - ∅20 - ∅25 |
|  T137.662N - Collet wiper DIN6388-EOC25 | |
|  X137.004.N - nr. 4 brushes for collet bore DIN6388-EOC25 | |

SET IN WOODEN BOX

ART. X118



Complete with concentric chuck ISO30 + 8 spring collets ER32

| Item | Item |
|---|---|
| X118.700.R | X118.800.R |
| complete with: concentric chuck ISO 30/ER32 T118.700.R | complete with: concentric chuck ISO 30/ER32 T118.800.R |
| spring collets | spring collets |
| ∅6 T119.060.N | ∅6 T119.060.N |
| ∅8 T119.080.N | ∅8 T119.080.N |
| ∅10 T119.100.N | ∅10 T119.100.N |
| ∅12 T119.120.N | ∅12 T119.120.N |
| ∅14 T119.140.N | ∅14 T119.140.N |
| ∅16 T119.160.N | ∅16 T119.160.N |
| ∅18 T119.180.N | ∅18 T119.180.N |
| ∅20 T119.200.N | ∅20 T119.200.N |

SET IN PLASTIC BOX

ART. X118



- Complete with concentric chuck HSK63F + 8 spring collets ER40

| Item | Item |
|---|------------|
| X118.980.R | |
| complete with: concentric chuck HSK63F/ER40 | T118.980.R |
| spring collets | |
| ∅6 | T123.060.N |
| ∅8 | T123.080.N |
| ∅10 | T123.100.N |
| ∅12 | T123.120.N |
| ∅16 | T123.160.N |
| ∅18 | T123.180.N |
| ∅20 | T123.200.N |
| ∅25 | T123.250.N |

SET IN PLASTIC BOX

ART. X118



- Complete with concentric chuck HSK63F + 8 spring collets ER32

| Item | Item |
|---|------------|
| X118.976.R | |
| complete with: concentric chuck HSK63F/ER32 | T118.976.R |
| spring collets | |
| ∅6 | T119.060.N |
| ∅8 | T119.080.N |
| ∅10 | T119.100.N |
| ∅12 | T119.120.N |
| ∅14 | T119.140.N |
| ∅16 | T119.160.N |
| ∅18 | T119.180.N |
| ∅20 | T119.200.N |

SET IN PLASTIC BOX

ART. X118



- Complete with concentric chuck HSK63F with ball bearing nut + 8 spring collets EOC25

| Item | Item |
|--|------------|
| X118.984.R | |
| complete with: concentric chuck HSK63F/EOC25 | T118.984.R |
| spring collets | |
| ∅6 | T124.060.N |
| ∅8 | T124.080.N |
| ∅10 | T124.100.N |
| ∅12 | T124.120.N |
| ∅16 | T124.160.N |
| ∅18 | T124.180.N |
| ∅20 | T124.200.N |
| ∅25 | T124.250.N |

TORQUE WRENCHES

While setting a tool it is extremely important to tighten it appropriately.

If not effectively tight indeed a cutting tool could slide away from the tool holder during the working process.

On the other side, an excessive tightening can cause damages to the tool holder or spring collet or the tool itself.

The wrench indicates when the torque (Nm) is reached according to the value in the corresponding table.

TORQUE WRENCHES FOR "MINI" NUTS

ART. Z052

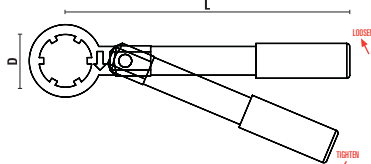

| Item | D | L | Nm | Threaded nut |
|------------|----|-----|----|--------------|
| Z052.702.N | 22 | 175 | 28 | ER16 Mini |
| Z052.704.N | 35 | 185 | 40 | ER25 Mini |

TORQUE WRENCHES FOR "STANDARD" NUTS

ART. Z052

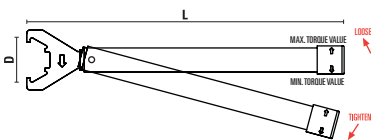

Dr. ① Collets as per drawing n. 1 must be tightened by setting the minimum torque value and rotating the handle counterclockwise.

Dr. ② Collets as per drawing n. 2 must be tightened by setting the maximum torque value and rotating the handle clockwise.

| Item | D | L | Nm (Dr. 1) | Nm (Dr. 2) | Threaded nut |
|------------|----|-----|------------|------------|--------------|
| Z052.712.N | 40 | 400 | 40-55 | 80-90 | ER25 |
| Z052.713.N | 50 | 400 | 66-70 | 120-130 | ER32 |
| Z052.714.N | 63 | 450 | 110-120 | 190-200 | ER40 |

CHIAVI DINAMOMETRICHE A SETTORE

ART. Z052

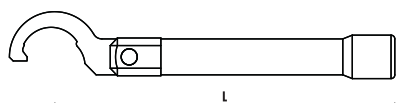

| Item | D | L | Nm (Dr. 1) | Nm (Dr. 2) | Threaded nut |
|------------|-------|-----|------------|------------|----------------|
| Z052.732.N | 58-62 | 380 | 110-120 | 190-200 | DIN 6388/EOC25 |
| Z052.735.N | 50 | 380 | 110-120 | 190-200 | Z091.005.R |

KEYS

ART. Z052

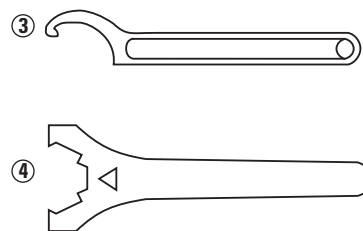

| Item | Draw. | Description | Threaded nut |
|------------|-------|---|---------------|
| Z052.300.N | 3 | Wrench 34/38 | DIN6388/EOC12 |
| Z052.301.N | 3 | Wrench 40/42 | Z091.000.R |
| Z052.305.N | 3 | Wrench 4850 | Z091.005.R |
| Z052.310.N | 3 | Wrench 58/62 | DIN6388/EOC25 |
| Z052.314.N | 4 | Wrench for dust & chip extraction nut D=80 | |
| Z052.315.N | 4 | Wrench for dust & chip extraction nut D=92 | |
| Z052.401.N | 4 | Wrench for collet nut ER 32 "standard" type | |
| Z052.402.N | 4 | Wrench for collet nut ER 40 "standard" type | |
| Z052.407.N | 4 | Wrench for collet nut ER 25 "standard" type | |

COLLET NUTS

ART. Z091

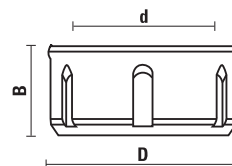



| Item | Type | D | B | d | Rot. |
|------------|-----------------------------------|----|------|-----------|-------|
| Z091.000.R | For spring collets Art. T117 | 40 | 20 | M 30x1,5 | RH |
| Z091.000.L | For spring collets Art. T117 | 40 | 20 | M 30x1,5 | LH |
| Z091.001.R | DIN 6499 (ER 32) | 50 | 23 | M 40x1,5 | RH |
| Z091.001.L | DIN 6499 (ER 32) | 50 | 23 | M 40x1,5 | LH |
| Z091.002.R | DIN 6499 (ER 40) | 63 | 25 | M 50x1,5 | RH |
| Z091.002.L | DIN 6499 (ER 40) | 63 | 25 | M 50x1,5 | LH |
| Z091.005.R | For spring collets T133 | 50 | 23 | M 40x1,5 | RH |
| Z091.100.R | DIN 6499 (ER 25) ball bearing nut | 42 | 20 | M 32x1,5 | RH/LH |
| Z091.101.R | DIN 6499 (ER 32) ball bearing nut | 50 | 25 | M 40x1,5 | RH/LH |
| Z091.102.R | DIN 6499 (ER 40) ball bearing nut | 63 | 27 | M 50x1,5 | RH/LH |
| Z091.103.R | DIN 6499 (ER 25) | 42 | 20 | M 32x1,5 | RH |
| Z091.104.R | DIN 6499 (ER 20) | 35 | 19 | M 25x1,5 | RH |
| Z091.105.R | DIN 6499 (ER 16) | 32 | 17,5 | M 22x1,5 | RH |
| Z091.202.R | DIN 6388 (EOC25) | 60 | 30 | M 48x2 | RH |
| Z091.203.R | DIN 6388 (EOC25) ball bearing nut | 60 | 30 | M 48x2 | RH/LH |
| Z091.205.R | DIN 6388 (EOC12) | 35 | 28 | M 27x1,5 | RH |
| Z091.301.R | ETS 32 | 50 | 22 | M 40x1,5 | RH |
| Z091.302.R | ETS 40 | 63 | 25 | M 50x1,5 | RH |
| Z091.403.R | ER 25 Type mini | 35 | 20 | M 30x1 | RH |
| Z091.404.R | ER 20 Type mini | 28 | 19 | M 24x1 | RH |
| Z091.405.R | ER 16 Type mini | 22 | 18 | M 19x1 | RH |
| Z091.406.R | ER 11 Type mini | 16 | 12 | M 13x0,75 | RH |

You can find all spare parts in the section n. 10

TORQUE WRENCHES FOR "NO-NOISE" NUTS

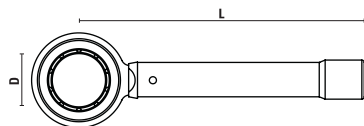
ART. Z052

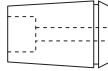

- Dr. ①  Collets as per drawing n. 1 must be tightened by setting the minimum torque value and rotating the handle counterclockwise.
- Dr. ②  Collets as per drawing n. 2 must be tightened by setting the maximum torque value and rotating the handle clockwise.

| Item | D | L | Nm (dis. 1) | Nm (dis. 2) | Threaded nut |
|------------|----|-----|-------------|-------------|----------------|
| Z052.790.N | 32 | 400 | 25-35 | 45-55 | ER 16 |
| Z052.793.N | 50 | 400 | 65-70 | 120-130 | ER 32 |
| Z052.795.N | 60 | 400 | 110-120 | 190-200 | DIN 6388/EOC25 |

"NO-NOISE" COLLET NUTS

ART. Z091

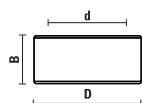

- Recommended when using router bits working at higher RPM
- Threaded nut with ground contours, remarkable reduction of noise

| Item | Type | D | B | d | Rot. |
|------------|-------------------|----|------|----------|------|
| Z091.501.R | DIN 6499 (ER 32) | 50 | 23 | M 40x1,5 | RH |
| Z091.505.R | DIN 6499 (ER 16) | 32 | 17,5 | M 22x1,5 | RH |
| Z091.522.R | DIN 6499 (EOC 25) | 60 | 30 | M 48x2 | RH |

You can find all spare parts in the section n. 10

ADAPTERS FOR CIRCULAR SAWBLADES

ART. T128

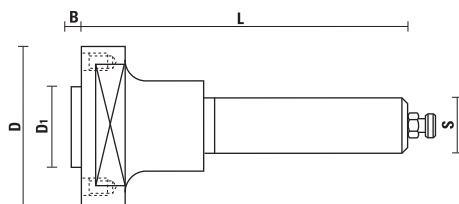

- Nr. 4 pin holes with M6/90°
- Complete with nr. 4 screws to fix the sawblade
- Recommended to use sawblades with diameters between 150 and 200 mm
- Item T128.143.R (S=16) is especially made to be mounted on aggregate heads

| Item | D | D1 | B | S | L | Pin holes |
|-----------------------|----|----|-----|--------|----|-----------|
| T128.141.R NEW | 60 | 22 | 2,5 | ∅20x60 | 90 | 4/4/36 |



| Item | D | D1 | B | S | L | Pin holes |
|-----------------------|----|----|-----|--------|----|-----------|
| T128.140.R | 60 | 30 | 2,5 | ∅20x60 | 90 | 4/6/48 |
| T128.143.R NEW | 60 | 30 | 2,5 | ∅16x50 | 85 | 4/6/48 |
| T128.145.R NEW | 60 | 30 | 2,5 | ∅25x60 | 90 | 4/6/48 |



HSK-63 ADAPTERS FOR CIRCULAR SAWBLADES

ART. T128

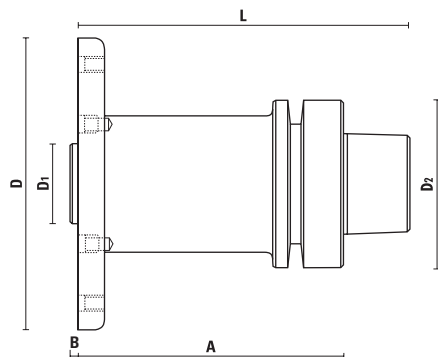
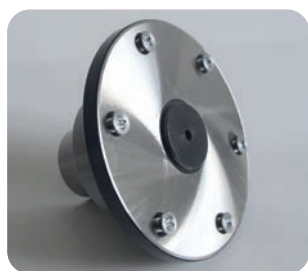

- Complete with nr. 6 screws (M6x10) for the proper assembly of sawblades with 60° at 90 mm distance
- For mounting sawblades with 30 mm bore
- For mounting sawblades with diameter between 200 and 350 mm.

| Item | Taper | A | D | D1 | D2 | B | L |
|-----------------------|---------|-----|-----|----|----|-----|-----|
| T128.160.R | HSK-63F | 40 | 110 | 30 | 63 | 2,5 | 65 |
| T128.165.R | HSK-63F | 100 | 110 | 30 | 63 | 2,5 | 125 |
| T128.170.R NEW | HSK-63E | 40 | 110 | 30 | 63 | 2,5 | 72 |
| T128.175.R NEW | HSK-63E | 100 | 110 | 30 | 63 | 2,5 | 132 |



Z051.014.R

EXAMPLE OF USE:

HSK63 adapter with mounted Saw Blade

OPTIONS:
Security flange (item Z092.100.N) to secure sawblades with maximum diameter of 400 mm by changing screws.

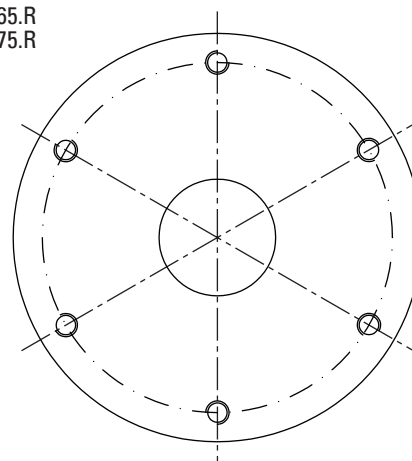
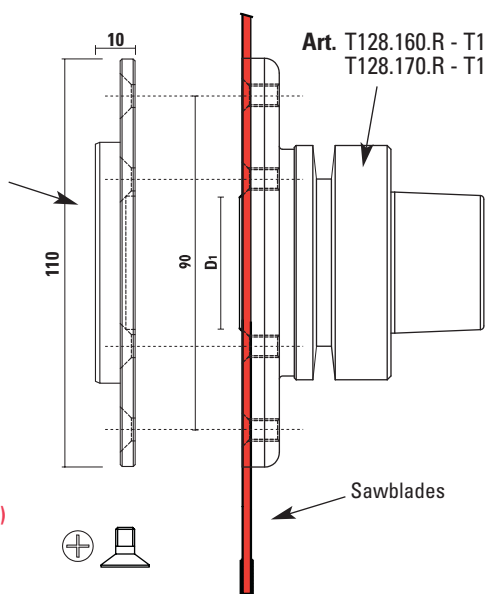

SCREW (ART. Z051.014.R)
M6x10 countersunk flat head screw

SECURITY FLANGE FOR SAW BLADES ADAPTERS

ART. Z092

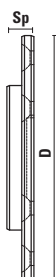

- To be used with our adapters, see items T128.160/165.R - T128.170/175.R
- **Security flange improves stability and reduces vibrations when precision cuts are needed**
- Complete with nr. 6 screws for the proper assembly of the sawblades with 60° at 90 mm distance
- **Maximum sawblades diameter of 400 mm**

ATTENTION:

Replace the adapters screws with those provided with the security flange.

| Item | D | Sp |
|-----------------------|-----|----|
| Z092.100.N NEW | 110 | 10 |



Z051.024.R

CUTTER ARBORS WITH ISO 30 TAPER

ART. T128

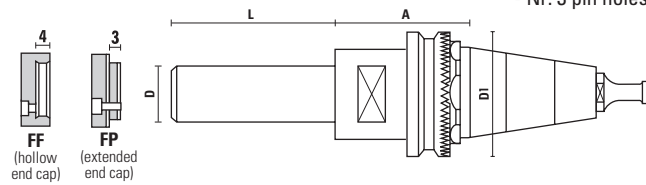

- Complete with retaining pawl page 7.39 and end cap page 10.14

- Nr. 3 pin holes to 120°

- Retaining pawl T118.790.R for: **Morbidelli, SCM**

| Item | Taper | A | D | D ₁ | L | End cap |
|-------------|--------|----|----|----------------|-----|-----------------|
| T128.690.N | ISO 30 | 39 | 30 | 49 | 70 | FF - Z092.001.R |
| T128.700.N | ISO 30 | 39 | 30 | 49 | 100 | FF - Z092.001.R |
| T128.690.NM | ISO 30 | 39 | 30 | 49 | 70 | FP - Z092.002.R |
| T128.700.NM | ISO 30 | 39 | 30 | 49 | 100 | FP - Z092.002.R |



Z051.016.R

CUTTER ARBORS WITH ISO 30 - ISO 40 TAPER

ART. T128

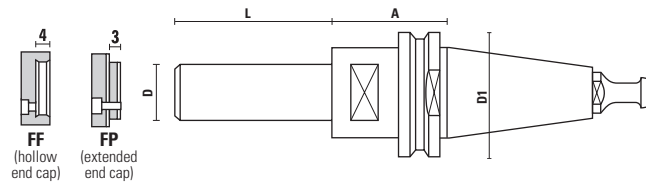

- Complete with retaining pawl page 7.39 and end cap page 10.14

- Other retaining pawl on request

Retaining pawl T118.891.R for: **Biesse, Masterwood - Bulleri (motor H.S.D.)**

| Item | Taper | A | D | D ₁ | L | End cap |
|----------------|--------|----|----|----------------|-----|-----------------|
| T128.790.N | ISO 30 | 35 | 30 | 50 | 70 | FF - Z092.001.R |
| T128.800.N | ISO 30 | 35 | 30 | 50 | 100 | FF - Z092.001.R |
| T128.790.NM | ISO 30 | 35 | 30 | 50 | 70 | FP - Z092.002.R |
| T128.800.NM | ISO 30 | 35 | 30 | 50 | 100 | FP - Z092.002.R |
| T128.800.N120 | ISO 30 | 35 | 30 | 50 | 120 | FF - Z092.001.R |
| T128.800.N120M | ISO 30 | 35 | 30 | 50 | 120 | FP - Z092.002.R |

Retaining pawl T118.792.R for: **Alberti, Vitap, Masterwood (motor G. Colombo)**

| Item | Taper | A | D | D ₁ | L | End cap |
|-------------|--------|----|----|----------------|-----|-----------------|
| T128.791.N | ISO 30 | 35 | 30 | 50 | 70 | FF - Z092.001.R |
| T128.801.N | ISO 30 | 35 | 30 | 50 | 100 | FF - Z092.001.R |
| T128.791.NM | ISO 30 | 35 | 30 | 50 | 70 | FP - Z092.002.R |
| T128.801.NM | ISO 30 | 35 | 30 | 50 | 100 | FP - Z092.002.R |

Retaining pawl T118.791.R (DIN 69872) for: **Busellato, Weeke, Ima, Bulleri, Maka, Cosmec, Reichenbacher, Elte**

| Item | Taper | A | D | D ₁ | L | End cap |
|-------------|--------|----|----|----------------|-----|-----------------|
| T128.792.N | ISO 30 | 35 | 30 | 50 | 70 | FF - Z092.001.R |
| T128.802.N | ISO 30 | 35 | 30 | 50 | 100 | FF - Z092.001.R |
| T128.792.NM | ISO 30 | 35 | 30 | 50 | 70 | FP - Z092.002.R |
| T128.802.NM | ISO 30 | 35 | 30 | 50 | 100 | FP - Z092.002.R |

Retaining pawl T118.893.R for: **Ima, Weeke, Maka, Reichenbacher, Stegherr**

| Item | Taper | A | D | D ₁ | L | End cap |
|-------------|--------|----|----|----------------|-----|-----------------|
| T128.850.N | ISO 40 | 35 | 30 | 63,5 | 100 | FF - Z092.001.R |
| T128.850.NM | ISO 40 | 35 | 30 | 63,5 | 100 | FP - Z092.002.R |



Z051.016.R

CUTTER ARBORS WITH HSK63F TAPER

ART. T128

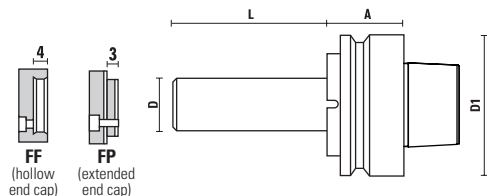

- Complete with end cap page 10.14

- Nr. 3 pin holes to 120°

| Item | Taper | A | D | D1 | L | End cap |
|--------------------|---------|----|--------|----|-----|-----------------|
| T128.970.R | HSK-63F | 33 | 30 | 63 | 70 | FF - Z092.001.R |
| T128.970.RM | HSK-63F | 33 | 30 | 63 | 70 | FP - Z092.002.R |
| T128.980.R | HSK-63F | 33 | 30 | 63 | 100 | FF - Z092.001.R |
| T128.980.RM | HSK-63F | 33 | 30 | 63 | 100 | FP - Z092.002.R |
| T128.980.R060M | HSK-63F | 33 | 30 | 63 | 60 | FP - Z092.002.R |
| T128.980.R065M | HSK-63F | 33 | 30 | 63 | 65 | FP - Z092.002.R |
| T128.980.R075M | HSK-63F | 33 | 30 | 63 | 75 | FP - Z092.002.R |
| T128.980.R080M | HSK-63F | 33 | 30 | 63 | 80 | FP - Z092.002.R |
| T128.980.R085M | HSK-63F | 33 | 30 | 63 | 85 | FP - Z092.002.R |
| T128.980.R090M | HSK-63F | 33 | 30 | 63 | 90 | FP - Z092.002.R |
| T128.980.R095M | HSK-63F | 33 | 30 | 63 | 95 | FP - Z092.002.R |
| T128.980.R105M | HSK-63F | 33 | 30 | 63 | 105 | FP - Z092.002.R |
| T128.980.R110M | HSK-63F | 33 | 30 | 63 | 110 | FP - Z092.002.R |
| T128.980.R115M | HSK-63F | 33 | 30 | 63 | 115 | FP - Z092.002.R |
| T128.980.R120M | HSK-63F | 33 | 30 | 63 | 120 | FP - Z092.002.R |
| T128.980.R125M | HSK-63F | 33 | 30 | 63 | 125 | FP - Z092.002.R |
| T128.980.R130M | HSK-63F | 33 | 30 | 63 | 130 | FP - Z092.002.R |
| T128.980.R135M | HSK-63F | 33 | 30 | 63 | 135 | FP - Z092.002.R |
| T128.980.R140M | HSK-63F | 33 | 30 | 63 | 140 | FP - Z092.002.R |
| T128.980.R145M | HSK-63F | 33 | 30 | 63 | 145 | FP - Z092.002.R |
| T128.980.R150M | HSK-63F | 33 | 30 | 63 | 150 | FP - Z092.002.R |
| T128.980.R180M | HSK-63F | 33 | 30 | 63 | 180 | FP - Z092.002.R |
| T128.980.1x125M | HSK-63F | 33 | 1" | 63 | 125 | FP - Z092.008.R |
| T128.980.1,25x125M | HSK-63F | 33 | 1-1/4" | 63 | 125 | FP - Z092.010.R |
| T128.980.35x100 | HSK-63F | 33 | 35 | 63 | 100 | FF - Z092.003.R |
| T128.980.35x100M | HSK-63F | 33 | 35 | 63 | 100 | FP - Z092.004.R |
| T128.980.40x100 | HSK-63F | 33 | 40 | 63 | 100 | FF - Z092.005.R |
| T128.980.40x100M | HSK-63F | 33 | 40 | 63 | 100 | FP - Z092.006.R |

| Item | Type | A | D | D1 | L | End cap |
|--------------------|---------|----|--------|----|-----|-----------------|
| T128.972.R | HSK-63F | 42 | 30 | 63 | 70 | FF - Z092.001.R |
| T128.972.RM | HSK-63F | 42 | 30 | 63 | 70 | FP - Z092.002.R |
| T128.982.R | HSK-63F | 42 | 30 | 63 | 100 | FF - Z092.001.R |
| T128.982.RM | HSK-63F | 42 | 30 | 63 | 100 | FP - Z092.002.R |
| T128.982.R080 | HSK-63F | 42 | 30 | 63 | 80 | FF - Z092.001.R |
| T128.982.R080M | HSK-63F | 42 | 30 | 63 | 80 | FP - Z092.002.R |
| T128.982.R125 | HSK-63F | 42 | 30 | 63 | 125 | FF - Z092.001.R |
| T128.982.R125M | HSK-63F | 42 | 30 | 63 | 125 | FP - Z092.002.R |
| T128.982.1,25x125M | HSK-63F | 42 | 1-1/4" | 63 | 125 | FP - Z092.010.R |
| T128.982.35x100 | HSK-63F | 42 | 35 | 63 | 100 | FF - Z092.003.R |
| T128.982.35x100M | HSK-63F | 42 | 35 | 63 | 100 | FP - Z092.004.R |



Z051.016.R

CUTTER ARBORS WITH HSK-63E TAPER

ART. T128

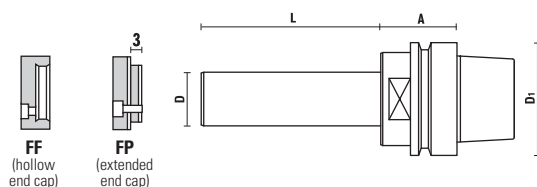

- Complete with end cap page 10.14

- Nr. 3 pin holes to 120°

| Item | Taper | A | D | D ₁ | L | End cap |
|-----------------------------|---------|----|----|----------------|-----|-----------------|
| T128.988.R | HSK-63E | 42 | 30 | 63 | 100 | FF - Z092.001.R |
| T128.988.RM NEW | HSK-63E | 42 | 30 | 63 | 100 | FP - Z092.002.R |
| T128.988.R140M NEW | HSK-63E | 42 | 30 | 63 | 140 | FP - Z092.002.R |
| T128.988.R160M NEW | HSK-63E | 42 | 30 | 63 | 160 | FP - Z092.002.R |
| T128.988.R180M NEW | HSK-63E | 42 | 30 | 63 | 180 | FP - Z092.002.R |
| T128.988.R190M NEW | HSK-63E | 42 | 30 | 63 | 190 | FP - Z092.002.R |
| T128.988.R220M NEW | HSK-63E | 42 | 30 | 63 | 220 | FP - Z092.002.R |
| T128.988.R230M NEW | HSK-63E | 42 | 30 | 63 | 230 | FP - Z092.002.R |
| T128.988.35x100 NEW | HSK-63E | 42 | 35 | 63 | 100 | FF - Z092.003.R |
| T128.988.35x100M NEW | HSK-63E | 42 | 35 | 63 | 100 | FP - Z092.004.R |
| T128.988.35x130M NEW | HSK-63E | 42 | 35 | 63 | 130 | FP - Z092.004.R |
| T128.988.35x150M NEW | HSK-63E | 42 | 35 | 63 | 150 | FP - Z092.004.R |
| T128.988.35x180M NEW | HSK-63E | 42 | 35 | 63 | 180 | FP - Z092.004.R |
| T128.988.35x200M NEW | HSK-63E | 42 | 35 | 63 | 200 | FP - Z092.004.R |
| T128.988.40x100 NEW | HSK-63E | 42 | 40 | 63 | 100 | FF - Z092.005.R |
| T128.988.40x100M NEW | HSK-63E | 42 | 40 | 63 | 100 | FP - Z092.006.R |
| T128.988.40x150M NEW | HSK-63E | 42 | 40 | 63 | 150 | FP - Z092.006.R |
| T128.988.40x200M NEW | HSK-63E | 42 | 40 | 63 | 200 | FP - Z092.006.R |



Z051.016.R

CUTTER ARBORS WITH HSK-85 TAPER

ART. T130 - T131 - T132

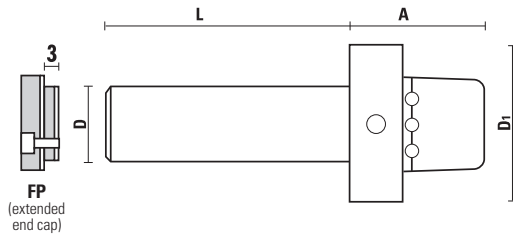

- Complete with end cap page 10.14
- Nr. 3 pin holes to 120°

for: **Weinig Powerlock system**

| Item | Taper | A | D | D1 | L | End cap |
|------------|--------|----|----|----|-----|-----------------|
| T130.060.N | HSK-85 | 58 | 30 | 85 | 60 | FP - Z092.002.R |
| T130.080.N | HSK-85 | 58 | 30 | 85 | 80 | FP - Z092.002.R |
| T130.100.N | HSK-85 | 58 | 30 | 85 | 100 | FP - Z092.002.R |
| T130.130.N | HSK-85 | 58 | 30 | 85 | 130 | FP - Z092.002.R |
| T130.150.N | HSK-85 | 58 | 30 | 85 | 150 | FP - Z092.002.R |
| T130.180.N | HSK-85 | 58 | 30 | 85 | 180 | FP - Z092.002.R |
| T130.200.N | HSK-85 | 58 | 30 | 85 | 200 | FP - Z092.002.R |
| T130.230.N | HSK-85 | 58 | 30 | 85 | 230 | FP - Z092.002.R |
| T130.240.N | HSK-85 | 58 | 30 | 85 | 240 | FP - Z092.002.R |
| | | | | | | |
| T131.080.N | HSK-85 | 58 | 35 | 85 | 80 | FP - Z092.004.R |
| T131.100.N | HSK-85 | 58 | 35 | 85 | 100 | FP - Z092.004.R |
| T131.120.N | HSK-85 | 58 | 35 | 85 | 120 | FP - Z092.004.R |
| T131.150.N | HSK-85 | 58 | 35 | 85 | 150 | FP - Z092.004.R |
| T131.200.N | HSK-85 | 58 | 35 | 85 | 200 | FP - Z092.004.R |
| | | | | | | |
| T132.060.N | HSK-85 | 58 | 40 | 85 | 60 | FP - Z092.006.R |
| T132.080.N | HSK-85 | 58 | 40 | 85 | 80 | FP - Z092.006.R |
| T132.100.N | HSK-85 | 58 | 40 | 85 | 100 | FP - Z092.006.R |
| T132.130.N | HSK-85 | 58 | 40 | 85 | 130 | FP - Z092.006.R |
| T132.150.N | HSK-85 | 58 | 40 | 85 | 150 | FP - Z092.006.R |
| T132.180.N | HSK-85 | 58 | 40 | 85 | 180 | FP - Z092.006.R |
| T132.200.N | HSK-85 | 58 | 40 | 85 | 200 | FP - Z092.006.R |
| T132.240.N | HSK-85 | 58 | 40 | 85 | 240 | FP - Z092.006.R |



Z051.016.R

CUTTER ARBORS WITH HSK-85S TAPER

ART. T132

- Complete with end cap page 10.14
- Nr. 3 pin holes to 120°



for: **SCM**

| Item | Taper | A | D | D1 | L | End cap |
|-------------|---------|----|----|----|-----|-----------------|
| T132.320.NS | HSK-85S | 58 | 50 | 85 | 320 | FF - Z092.050.R |



Z051.016.R

SPACERS 2-SIDES GRINDED

ART. YD300 - YD350 - YD400 - YD500 - YD600

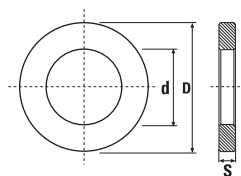

- For arbors Art. T128 - Art. T130 - Art. T131 - Art. T132
- Burnished
- Spacer rings fine-blanking processed for thickness $0,1 \pm 0,02$ mm (tolerance $\pm 0,02$)
- Spacer rings grinded on two sides for thickness $2 \pm 0,01$ mm (tolerance $\pm 0,01$)

| Item | d | D | S |
|-----------|----|----|-----|
| YD300.001 | 30 | 50 | 0,1 |
| YD300.002 | 30 | 50 | 0,2 |
| YD300.005 | 30 | 50 | 0,5 |
| YD300.010 | 30 | 50 | 1 |
| YD300.020 | 30 | 50 | 2 |
| YD300.030 | 30 | 50 | 3 |
| YD300.040 | 30 | 50 | 4 |
| YD300.050 | 30 | 50 | 5 |
| YD300.060 | 30 | 50 | 6 |
| YD300.080 | 30 | 50 | 8 |
| YD300.100 | 30 | 50 | 10 |
| YD300.120 | 30 | 50 | 12 |
| YD300.150 | 30 | 50 | 15 |
| YD300.200 | 30 | 50 | 20 |
| YD300.250 | 30 | 50 | 25 |
| YD300.300 | 30 | 50 | 30 |
| YD300.400 | 30 | 50 | 40 |
| YD300.500 | 30 | 50 | 50 |
| | | | |
| YD350.001 | 35 | 55 | 0,1 |
| YD350.002 | 35 | 55 | 0,2 |
| YD350.005 | 35 | 55 | 0,5 |
| YD350.010 | 35 | 55 | 1 |
| YD350.020 | 35 | 55 | 2 |
| YD350.030 | 35 | 55 | 3 |
| YD350.040 | 35 | 55 | 4 |
| YD350.050 | 35 | 55 | 5 |
| YD350.060 | 35 | 55 | 6 |
| YD350.080 | 35 | 55 | 8 |
| YD350.100 | 35 | 55 | 10 |
| YD350.120 | 35 | 55 | 12 |
| YD350.150 | 35 | 55 | 15 |
| YD350.200 | 35 | 55 | 20 |
| YD350.250 | 35 | 55 | 25 |
| YD350.300 | 35 | 55 | 30 |
| YD350.400 | 35 | 55 | 40 |
| YD350.500 | 35 | 55 | 50 |

| Item | d | D | S |
|-----------|----|----|-----|
| YD400.001 | 40 | 60 | 0,1 |
| YD400.002 | 40 | 60 | 0,2 |
| YD400.005 | 40 | 60 | 0,5 |
| YD400.010 | 40 | 60 | 1 |
| YD400.020 | 40 | 60 | 2 |
| YD400.030 | 40 | 60 | 3 |
| YD400.040 | 40 | 60 | 4 |
| YD400.050 | 40 | 60 | 5 |
| YD400.060 | 40 | 60 | 6 |
| YD400.080 | 40 | 60 | 8 |
| YD400.100 | 40 | 60 | 10 |
| YD400.120 | 40 | 60 | 12 |
| YD400.150 | 40 | 60 | 15 |
| YD400.200 | 40 | 60 | 20 |
| YD400.250 | 40 | 60 | 25 |
| YD400.300 | 40 | 60 | 30 |
| YD400.400 | 40 | 60 | 40 |
| YD400.500 | 40 | 60 | 50 |
| | | | |
| YD500.001 | 50 | 70 | 0,1 |
| YD500.002 | 50 | 70 | 0,2 |
| YD500.005 | 50 | 70 | 0,5 |
| YD500.010 | 50 | 70 | 1 |
| YD500.020 | 50 | 70 | 2 |
| YD500.030 | 50 | 70 | 3 |
| YD500.040 | 50 | 70 | 4 |
| YD500.050 | 50 | 70 | 5 |
| YD500.060 | 50 | 70 | 6 |
| YD500.080 | 50 | 70 | 8 |
| YD500.100 | 50 | 70 | 10 |
| YD500.120 | 50 | 70 | 12 |
| YD500.150 | 50 | 70 | 15 |
| YD500.200 | 50 | 70 | 20 |
| YD500.250 | 50 | 70 | 25 |
| YD500.300 | 50 | 70 | 30 |
| YD500.400 | 50 | 70 | 40 |
| YD500.500 | 50 | 70 | 50 |
| | | | |
| YD600.001 | 60 | 80 | 0,1 |
| YD600.002 | 60 | 80 | 0,2 |
| YD600.005 | 60 | 80 | 0,5 |
| YD600.010 | 60 | 80 | 1 |
| YD600.020 | 60 | 80 | 2 |
| YD600.030 | 60 | 80 | 3 |
| YD600.040 | 60 | 80 | 4 |
| YD600.050 | 60 | 80 | 5 |
| YD600.060 | 60 | 80 | 6 |
| YD600.080 | 60 | 80 | 8 |
| YD600.100 | 60 | 80 | 10 |
| YD600.120 | 60 | 80 | 12 |
| YD600.150 | 60 | 80 | 15 |
| YD600.200 | 60 | 80 | 20 |
| YD600.250 | 60 | 80 | 25 |
| YD600.300 | 60 | 80 | 30 |
| YD600.400 | 60 | 80 | 40 |
| YD600.500 | 60 | 80 | 50 |



SPACERS SET

ART. YD300 - YD350 - YD400 - YD500 - YD600

| Item | d | D |
|-----------|----|----|
| YD300.990 | 30 | 50 |
| YD350.990 | 35 | 55 |
| YD400.990 | 40 | 60 |
| YD500.990 | 50 | 70 |
| YD600.990 | 60 | 80 |

Complete with:

nr. 4 sp. 2 mm - nr. 3 sp. 4 mm - nr. 2 sp. 5 mm
nr. 2 sp. 10 mm - nr. 1 sp. 20 mm - nr. 1 sp. 30 mm

RETAINING PAWLS FOR CONCENTRIC CHUCK

ART. T118

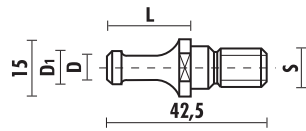

For: **Morbidelli, SCM**

| Item | Type | D1 | D | L | S |
|------------|--------|-----|-----|----|-----|
| T118.790.R | ISO 30 | 8,5 | 6,5 | 22 | M10 |

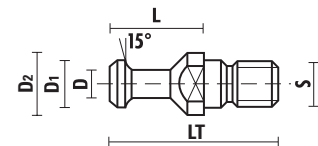

DIN 69872 for:
Anderson, Busellato, Weeke, Ima, Bulleri, Maka, Cosmec, Reichenbacher, Elte

| Item | Type | D1 | D2 | D | L | LT | S |
|------------|--------|----|----|----|----|----|-----|
| T118.791.R | ISO 30 | 13 | 17 | 9 | 24 | 44 | M12 |
| T118.893.R | ISO 40 | 19 | 23 | 14 | 26 | 54 | M16 |

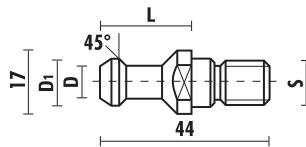

For: **Alberti, Vitap, Masterwood** (motor G. Colombo)

| Item | Type | D1 | D | L | S |
|------------|--------|------|---|----|-----|
| T118.792.R | ISO 30 | 12,8 | 9 | 24 | M12 |

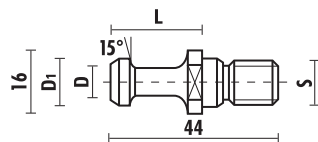

For: **Esseteam**

| Item | Type | D1 | D | L | S |
|------------|--------|----|---|----|-----|
| T118.793.R | ISO 30 | 12 | 8 | 24 | M12 |

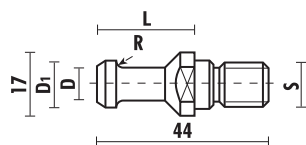

For: **CMS**

| Item | Type | D1 | D | L | R | S |
|------------|--------|------|---|----|-----|-----|
| T118.794.R | ISO 30 | 12,8 | 9 | 24 | 2,4 | M12 |

RETAINING PAWLS FOR CONCENTRIC CHUCK

ART. T118

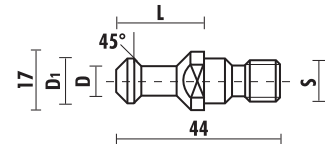

For: **Belotti**

| Item | Type | D1 | D | L | S |
|------------|--------|----|---|----|-----|
| T118.795.R | ISO 30 | 13 | 9 | 23 | M12 |

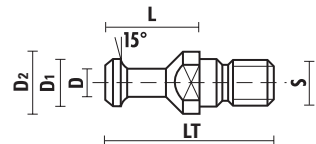

For: **Biesse** (until 9/9/92)

| Item | Type | D1 | D | L | S |
|------------|--------|----|---|----|-----|
| T118.890.R | ISO 30 | 13 | 9 | 24 | M12 |

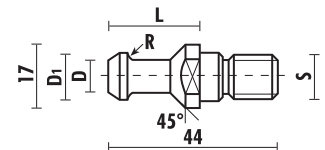

For: **Biesse** (after 9/9/92), **Masterwood** (motor H.S.D.), **Bulleri, Thermwood, Vitap**

| Item | Type | D1 | D | L | R | S |
|------------|--------|----|---|----|-----|-----|
| T118.891.R | ISO 30 | 12 | 8 | 24 | 3,2 | M12 |

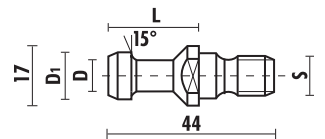

For: **Komo**

| Item | Type | D1 | D | L | S |
|------------|-------|----|---|----|-----|
| T118.894.R | BT 30 | 13 | 9 | 24 | M12 |

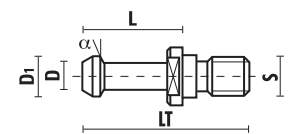

For: BT 30 - BT 40 **Shoda**, BT 35 **Heian**

| Item | Type | D1 | D | L | LT | α | S |
|---------------|-------|----|-----|------|----|-----|-----|
| T118.895.R | BT 30 | 11 | 7 | 23,5 | 43 | 30° | M12 |
| T118.896.R | BT 35 | 13 | 8,5 | 28 | 48 | 45° | M12 |
| T118.896.R030 | BT 35 | 13 | 8,5 | 28 | 48 | 30° | M12 |
| T118.897.R | BT 40 | 15 | 10 | 35 | 60 | 45° | M16 |

MACHINES AND TOOLS MAINTENANCE:

Coupling seats in the electrospindles, in the collet chucks or in the spring collets should be always clean and spotless in order to avoid a wrong position of the tool causing bad finishing results or even tool breakage.

By using regularly the tapers **Klein** these risks are reduced and the tool life span is highly increased.

SPINDLE WIPERS

ART. T137

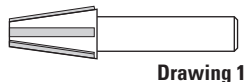

Drawing 1

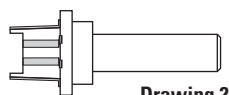

Drawing 2

- To maintain the inside of the spindle mouth clean
- Ensures extreme cleanliness of tapered spindles and it maintains the precision and prolongs the life of your expensive machines, cutting tools and toolholders
- To **avoid wrong positioning of the holders and ensure best contact between tool and tool holder for a better coupling**
- Suitable for all tool holder types
- A **proper maintenance** of the collet and the spindle with Klein® products will allow your tooling to live longer with better performance

| Item | Concentric chuck | Drawing |
|-----------------------|------------------|---------|
| T137.002.N | Taper 2 (MK2) | 1 |
| T137.003.N | Taper 3 (MK3) | 1 |
| | | |
| T137.030.N | ISO 30/BT 30 | 1 |
| T137.040.N | ISO 40/BT 40 | 1 |
| | | |
| T137.125.N NEW | HSK25 A - C - E | 2 |
| T137.132.N NEW | HSK32 A - C - E | 2 |
| T137.140.N NEW | HSK40 A - C - E | 2 |
| T137.150.N NEW | HSK50 A - C - E | 2 |
| T137.250.N NEW | HSK50 B - D - F | 2 |
| T137.163.N | HSK63 A - C - E | 2 |
| T137.263.N | HSK63 B - D - F | 2 |

CONE AND COLLET WIPERS

ART. T137

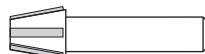

- To maintain the inside of the collet clean
- To avoid wrong positioning of the collet due to resin
- For all collet types

| Item | Collet type |
|-----------------------|----------------------|
| T137.516.N NEW | ER16 |
| T137.520.N NEW | ER20 |
| T137.525.N | ER 25-ETS 25-DIN6499 |
| T137.532.N | ER 32-ETS 32-DIN6499 |
| T137.540.N | ER 40-ETS 40-DIN6499 |
| T137.662.N | EOC 25-DIN 6388 |

BRUSHES FOR COLLET BORE

ART. T137



- To clean the collet bore
- To avoid wrong tool positioning caused by resin

| Item | Collet bore |
|------------|-------------|
| T137.906.N | 3÷6 |
| T137.911.N | 6,4÷11 |
| T137.918.N | 12÷18 |
| T137.925.N | 19÷25 |

X137.004.N Collet brush set 3÷25



WIPE OFF KIT FOR CNC

ART. X137



- For a perfect maintenance of your CNC router or machining centres
- For cleaning boring machines and CNC router machines. Ensures **extreme cleanliness of tapered spindles and it maintains the precision and prolongs the life of your expensive machines, cutting tools and toolholders**
- Carton box
- Available for every tool holders cone and spring collets
- A complete set with:
 - Cone and spindle wiper for every kind of tool holder (Item T137);
 - Collet wiper to avoid wrong positioning of the collet (Item T137);
 - No° 4 brushes for collet bore (Item X137)

| Item | Description |
|-----------------------|---|
| X137.000.N | HSK63F/ER32 T137.263.N + T137.532.N + X137.004.N |
| X137.001.N | ISO30/ER32 T137.030.N + T137.532.N + X137.004.N |
| X137.002.N | HSK63F/DIN6388 T137.263.N + T137.662.N + X137.004.N |
| X137.003.N NEW | HSK25E/ER 16 T137.125.N + T137.516.N + X137.004.N |
| X137.005.N | HSK63F/ER40 T137.263.N + T137.540.N + X137.004.N |
| X137.006.N | ISO30/ER40 T137.030.N + T137.540.N + X137.004.N |
| X137.010.N NEW | HSK32E/ER25 T137.132.N + T137.525.N + X137.004.N |
| X137.011.N NEW | HSK40E/ER25 T137.140.N + T137.525.N + X137.004.N |
| X137.012.N NEW | HSK50E/ER32 T137.150.N + T137.532.N + X137.004.N |
| X137.013.N NEW | HSK50F/ER32 T137.250.N + T137.532.N + X137.004.N |

ADJUSTABLE DEMOUNT DEVICES

ART. T139

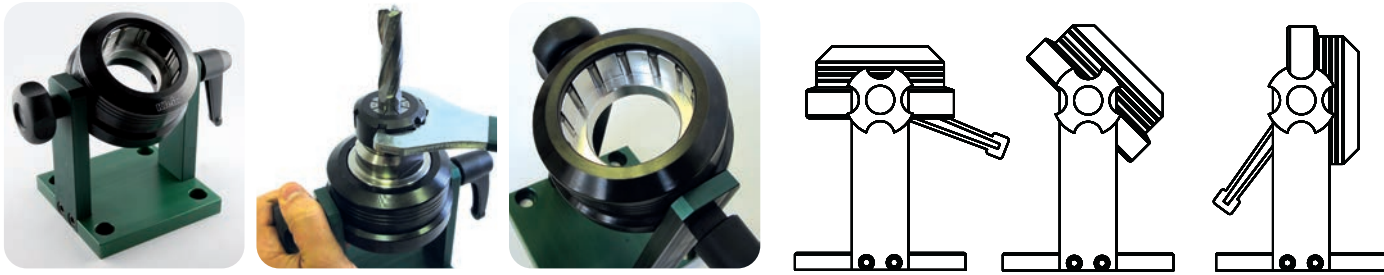

- The tool holder has to be blocked on the flange diameter which is made in special and durable steel
- Auto-locking roller bearing design for the fastest tool changes and no slippage.
- It is adjustable from 0° to 90°
- Wide range of tightening stand/locking devices available for HSK32, HSK40, HSK50, HSK63, ISO30 and ISO40 spindles
- Easy to be mount near the machine thanks to four holes on the basement. NB: Tightening device must be fixed before using.



| Item | Machine |
|-----------------------|--|
| T139.132.N NEW | For HSK32 tool holder Ø 32 mm |
| T139.140.N NEW | For HSK40 tool holder Ø 40 mm |
| T139.150.N | For ISO 30/HSK63 tool holder Ø 50 mm |
| T139.158.N | For ISO 30 tool holder Ø 58 (Motor ELTE/ESSETEAM/THERMWOOD) |
| T139.163.N | For HSK63 tool holder Ø 63 |
| T139.164.N | For ISO 40 tool holder Ø 63,5 |

DEMOUNT DEVICES FOR FLANGE Ø80 - Ø85

ART. T139

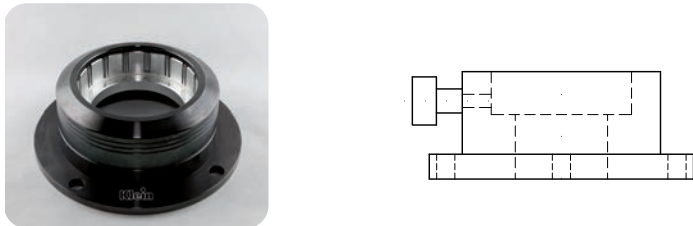

Tool holder to be blocked on the flange diameter

| Item | Machine |
|------------|---------------------------------------|
| T139.180.N | For tool holder Ø 80 mm |
| T139.185.N | For tool holder Ø 85 mm (Weinig, SCM) |

DEMOUNT DEVICES

ART. T139



Suitable for toolholders with key seat 41 mm

| Item | Machine |
|------------------------|-------------------------------|
| T139.003.N selling out | For ISO 40 tool holder Ø 63,5 |

ISO 30 DEMOUNT DEVICES

ART. T139



- For ISO30 special
- Horizontal and vertical type

| Item | Machine |
|------------------------|------------------|
| T139.001.N selling out | Morbidelli - SCM |

DUST & CHIP EXTRACTION NUT

ART. T139

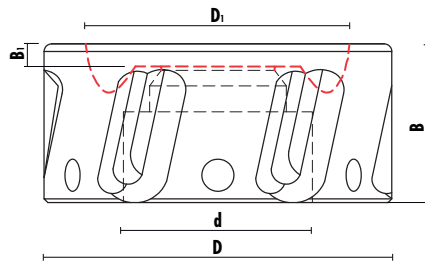

- Tool body in light alloy with a special surface coating against wear and corrosion for a maximum chips evacuation
- Optimal gap between Tornado® and material is 2 mm (0.078"). It works properly up to 10 mm (0.38")
- Smaller diameter: (92 mm) in order to be mounted on every CNC router/machining centre
- Suitable for every type of collet chuck (HSK, ISO, BT, ...)
- Maximum speed rotation at 20.000 RPM
- Balanced at G2,5, weight 0,256 kg

Watch the Video on YouTube



| Item | Type | D | D1 | B | B1 | d | Rot. |
|------------------------|-----------------|----|----|----|----|----------|------|
| T139.501.RK NEW | DIN6499 (ER32) | 92 | 70 | 40 | 6 | M 40x1,5 | RH |
| T139.502.RK NEW | DIN6499 (ER40) | 92 | 70 | 42 | 6 | M 50x1,5 | RH |
| T139.503.RK NEW | DIN6499 (ER25) | 92 | 70 | 42 | 6 | M 32x1,5 | RH |
| T139.522.RK NEW | DIN6388 (EOC25) | 92 | 70 | 42 | 6 | M 48x2 | RH |
| T139.581.RK NEW | DIN6499 (ER32) | 80 | 64 | 42 | 6 | M 40x1,5 | RH |

DUST & CHIP EXTRACTION NUT SET

ART. X139



- Complete with: n° 1 extraction nut
- n° 1 hook wrench: Ø 92= key 95/100
- Ø 80= key 80/90
- Carton box

| Item | Description | Type |
|------------------------|--------------------------|-----------------|
| X139.501.RK NEW | T139.501.RK + Z052.315.N | DIN6499 (ER32) |
| X139.502.RK NEW | T139.502.RK + Z052.315.N | DIN6499 (ER40) |
| X139.503.RK NEW | T139.503.RK + Z052.315.N | DIN6499 (ER25) |
| X139.522.RK NEW | T139.522.RK + Z052.315.N | DIN6388 (EOC25) |
| X139.581.RK NEW | T139.581.RK + Z052.314.N | DIN6499 (ER32) |

Tornado: the new dust & chips extraction nut helps both dust and chip evacuation during Nesting and conventional CNC Routing operations. Easy to assemble directly on the collet chuck instead of the standard nut, the new Klein Tornado® provides a big improvement of dust evacuation, removing it from the workpiece directly into the centralized extraction system of the CNC machines.

DUST & CHIP EXTRACTION NUT SET

ART. X139



- Complete with: n° 2 extraction nuts (ER32 - ER40)
- n° 1 hook wrench 95/100
- Carton box

| Item | Description |
|------------------------|--|
| X139.990.RK NEW | T139.501.RK + T139.502.RK + Z052.315.N |

TORQUE WRENCHES

ART. Z052



| Item | Type | L |
|-----------------------|-----------------|-----|
| Z052.722.N NEW | DIN6499 (ER25) | 480 |
| Z052.723.N NEW | DIN6499 (ER32) | 480 |
| Z052.724.N NEW | DIN6499 (ER40) | 480 |
| Z052.728.N NEW | DIN6388 (EOC25) | 480 |

EASY TO MOUNT LIKE A STANDARD CLAMPING NUT

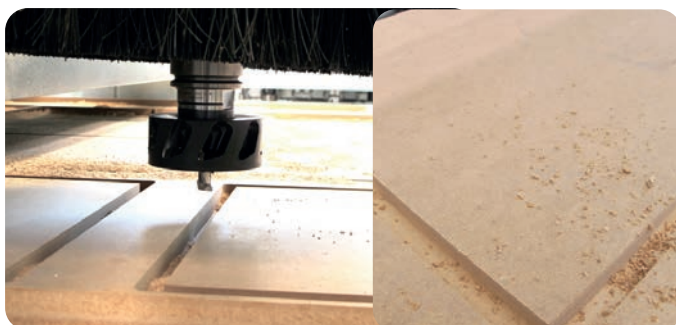

WORKING WITH TORNADO

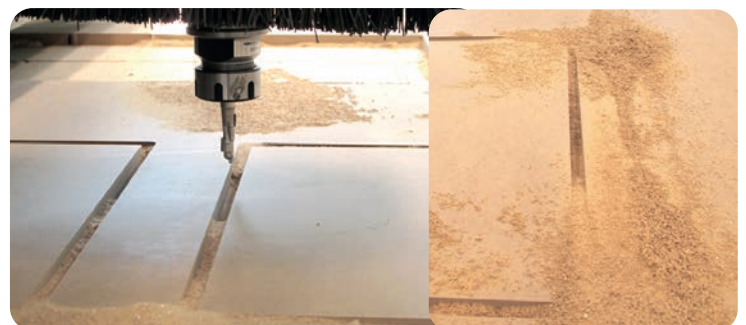

WORKING WITHOUT TORNADO

PROFILE CUTTERS, GROUP 1

ART. T130

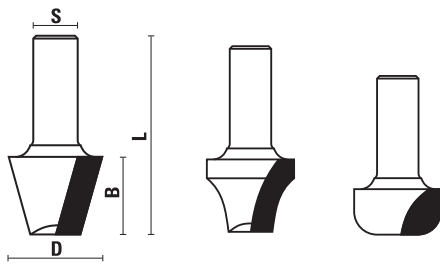

- HW and HS
- Z=2
- RH rotation

| D | B |
|---------|----|
| 11÷20 | 20 |
| 11÷20 | 30 |
| 11÷20 | 40 |
| 11÷20 | 50 |
| 21÷30 | 20 |
| 21÷30 | 30 |
| 21÷30 | 40 |
| 21÷30 | 50 |
| 21÷30 | 60 |
| 31÷40 | 20 |
| 31÷40 | 30 |
| 31÷40 | 40 |
| 31÷40 | 50 |
| 31÷40 | 60 |
| 41÷50 | 20 |
| 41÷50 | 30 |
| 41÷50 | 40 |
| 41÷50 | 50 |
| 41÷50 | 60 |
| 51÷60 | 30 |
| 51÷60 | 40 |
| 51÷60 | 50 |
| 51÷60 | 60 |
| 61÷70 | 30 |
| 61÷70 | 40 |
| 61÷70 | 50 |
| 71÷80 | 30 |
| 71÷80 | 40 |
| 81÷90 | 30 |
| 81÷90 | 40 |
| 91÷100 | 30 |
| 91÷100 | 40 |
| 101÷120 | 30 |

Price depends on the diameter and length of the cutters.
For a specific quote a detailed drawing or a sample are required.

Insert router bits see page 9.09

PROFILE CUTTERS, GROUP 2

ART. T131

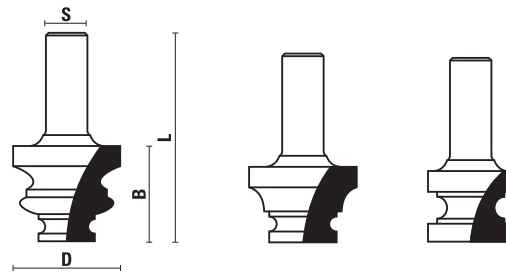

- HW and HS
- Z=2
- RH rotation

| D | B |
|---------|----|
| 11÷20 | 20 |
| 11÷20 | 30 |
| 11÷20 | 40 |
| 11÷20 | 50 |
| 21÷30 | 20 |
| 21÷30 | 30 |
| 21÷30 | 40 |
| 21÷30 | 50 |
| 21÷30 | 60 |
| 31÷40 | 20 |
| 31÷40 | 30 |
| 31÷40 | 40 |
| 31÷40 | 50 |
| 31÷40 | 60 |
| 41÷50 | 20 |
| 41÷50 | 30 |
| 41÷50 | 40 |
| 41÷50 | 50 |
| 41÷50 | 60 |
| 51÷60 | 30 |
| 51÷60 | 40 |
| 51÷60 | 50 |
| 51÷60 | 60 |
| 61÷70 | 30 |
| 61÷70 | 40 |
| 61÷70 | 50 |
| 71÷80 | 30 |
| 71÷80 | 40 |
| 81÷90 | 30 |
| 81÷90 | 40 |
| 91÷100 | 30 |
| 91÷100 | 40 |
| 101÷120 | 30 |

Price depends on the diameter and length of the cutters.
For a specific quote a detailed drawing or a sample are required.

Insert router bits see page 9.09

SOLID CARBIDE ROUTER BITS:

Useful information:

Klein offers a very wide range of solid carbide router bits which can satisfy almost all exigencies by using a CNC machine.

TECHNICAL DATA:

• Tungsten-carbide (Widia): is the most suitable material to use on CNC machines assuring the best performances.

• FLUTE GEOMETRY:

- Up Cut style, **for a better finish on the bottom of the material**

Good finish on bottom side



- Down Cut Style, **for a better finish on the top surface**

Good finish on panel top side



- Compression Style, **for a good finish on either top and bottom surface, particularly on laminated materials**

Excellent finish on both upper and lower side

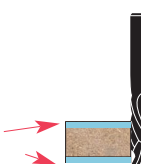

- NUMBER OF TEETH: **Z=1:** allow heavy duties on soft materials and an excellent chip evacuation
Z=2: allow a better finish on hard materials and a good chip evacuation
Z=3: allow an excellent finish on all types of materials
Z=2/Z=3 with chipbreaker: ideal for heavy duties

N.B.: Increasing the number of teeth should increase also the feed speed in order to preserve the tool from burning or early wearing out.

| Minimum clamping tool length | |
|------------------------------|-----------------------|
| Shank diameter S (mm) | Minimum length X (mm) |
| S ≤ 10 | X ≥ 20 |
| 10 < S < 25 | X = S x 2 |
| S ≥ 25 | X = S x 1,8 |

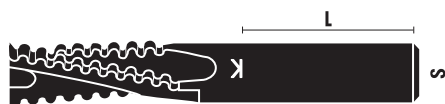

N.B.:

All **Klein** spiral router bits have technical data, dimensions and type of material marked on the shank. Moreover the sign X indicates the minimum clamping length according to the standard EN847-2

The following reference tables are provided just as a guide, while various other conditions must be always taken in consideration, such as the characteristics of the wood piece (humidity, veins, etc.), the machine and tooling conditions, etc.

HOW TO CHOSE THE RIGHT SOLID CARBIDE SPIRAL BIT FOR ROUTING ON A CNC MACHINE

| Router Bits Klein | Woods | | | |
|--|---|---|---------------------------------------|---|
| | Softwood (Cider, Poplar, Pine, etc.) | Hardwood (Ash, Walnut, Beech, Oak, Teak, etc.) | Pressed Wood (Plywood, Blockboard) | Laminated Wood (Veneered, melamine coated panels, HPL, etc.) |
| T141/T151 - Z=1 - Page 7.46/7.50 | XXX | XXX | X | - |
| T142/T152 - Z=2 - Page 7.47/7.51 | XXX | XXX | X | XX |
| T143/T153 - Z=3 - Page 7.48/7.51 | XX | XX | XXX | XXX |
| T144/T154 - Z=3 With chipbreaker Page 7.49/7.51-7.52 | XXX | XXX | XXX | XX |
| T155 - Z=1+1 - Page 7.52 | XX | XX | X | X |
| T156 - Z=2+2 - Page 7.53 | X | XX | XXX | XXX |
| T170/T171 - Z=2 With chipbreaker Page 7.56 | X | X | XX | XX |

X = Satisfactory

XX = Good

XXX = Excellent

- = not suggested

Technical data and images are just an indication. **SISTEMI** srl reserves the right to modify the above information at any time and without notice

REFERENCE TABLE FOR CALCULATING FEEDING RATES IN THE WOODWORKING

| Reference table for calculating feeding rates (mt/min ⁻¹) | | | | | |
|---|------|----------|----------|-------|----------------|
| DIAMETER | ITEM | SOFTWOOD | HARDWOOD | MDF | LAMINATED WOOD |
| Ø 3 | T141 | 2,40 | 2,40 | 2,40 | - |
| | T142 | 3,20 | 2,60 | 3,00 | - |
| | T143 | - | - | - | - |
| | T144 | - | - | - | - |
| | T156 | - | - | - | - |
| Ø 6 | T141 | 3,70 | 3,60 | 3,40 | - |
| | T142 | 4,00 | 3,70 | 3,90 | - |
| | T143 | - | - | - | - |
| | T144 | - | - | - | - |
| | T156 | - | - | - | - |
| Ø 8 | T141 | 4,30 | 4,00 | 3,80 | - |
| | T142 | 5,00 | 4,30 | 4,90 | - |
| | T143 | 6,00 | 4,60 | 5,20 | 5,80 |
| | T144 | 8,20 | 6,60 | 6,80 | - |
| | T156 | 6,60 | 5,20 | 5,70 | 6,50 |
| Ø 10 | T141 | 4,90 | 4,90 | 3,80 | - |
| | T142 | 6,20 | 4,60 | 5,40 | - |
| | T143 | 7,30 | 5,00 | 6,10 | 6,80 |
| | T144 | 9,10 | 6,60 | 7,40 | - |
| | T156 | 6,70 | 5,10 | 6,00 | 6,60 |
| Ø 12 | T141 | 5,10 | 4,90 | 4,20 | - |
| | T142 | 6,50 | 5,20 | 5,40 | - |
| | T143 | 7,90 | 6,30 | 6,80 | 7,40 |
| | T144 | 10,20 | 8,10 | 8,30 | - |
| | T156 | 6,90 | 5,10 | 6,00 | 6,70 |
| Ø 16 | T141 | - | - | - | - |
| | T142 | 7,70 | 6,10 | 6,90 | - |
| | T143 | 9,50 | 7,90 | 8,10 | 9,10 |
| | T144 | 11,80 | 9,00 | 9,50 | - |
| | T156 | 7,30 | 6,00 | 6,30 | 6,80 |
| Ø 20 | T141 | - | - | - | - |
| | T142 | 8,60 | 7,30 | 7,90 | - |
| | T143 | 10,80 | 8,50 | 8,90 | 10,00 |
| | T144 | 15,00 | 11,00 | 11,90 | - |
| | T156 | 8,00 | 6,90 | 7,20 | 7,00 |

Technical data and images are just an indication. **SISTEMI** srl reserves the right to modify the above information at any time and without notice.

THE RECOMMENDED FEED RATES WERE CALCULATED TAKING IN CONSIDERATION THE FOLLOWING PARAMETERS:

- **efficient machinery** in excellent conditions;
- **wood piece** perfectly clamped;
- **working solid material** (if not, parameters can be increased)
- **wood piece dry;**
- RPM 18.000 (working at a different rotation speed the feed rate should change accordingly)
- cutting depth two times the router bit diameter (the feed rate increases by 25% when the cutting depth is like the tool diameter – the feed rate decreases by 25% when the cutting depth is three times the tool diameter)
- router bits up cuted style
- better use down cut router bits if the vacuum clamping is not strong enough
- using down cut style bits we suggest a maximum cutting depth like the half of the tool diameter, otherwise there is not enough chip flow

SISTEMI suggest:

for working softwood

| | Good | Excellent |
|-------------|----------------|-----------|
| Single pass | T155+T141/T151 | T142/T152 |
| Roughing | T144/T154 | T144/T154 |
| Finishing | T142/T152 | T143/T153 |

for working hardwood

| | Good | Excellent |
|-------------|-----------|-----------|
| Single pass | T142/T152 | T142/T152 |
| Roughing | T144/T154 | T144/T154 |
| Finishing | T142/T152 | T143/T153 |

for working MDF

| | Good | Excellent |
|-------------|------|-----------|
| Single pass | T142 | T145 |
| Roughing | T170 | T144 |
| Finishing | T145 | T143 |

for working laminated and veneered chipboard

| | Good | Excellent |
|-------------|------|-----------|
| Single pass | T156 | T156 |

for working hard plastic (nylon, corian®, acrylic)

| | Good | Excellent |
|-------------|-----------|-----------|
| Single pass | T141 | T142 |
| Roughing | T170 | T144 |
| Finishing | T156/T142 | T156/T142 |

Conversion chart inch/mm

| Inches - Millimeters | Inches - Millimeters |
|----------------------|----------------------|
| 1/32" = 0,794 | 3/8" = 9,525 |
| 1/16" = 1,588 | 1/2" = 12,7 |
| 1/8" = 3,175 | 5/8" = 15,875 |
| 3/16" = 4,762 | 3/4" = 19,050 |
| 1/4" = 6,35 | 7/8" = 22,225 |
| 5/16" = 7,938 | 1" = 25,4 |

SOLID CARBIDE SPIRAL CUTTERS, FINISH STYLE Z=1

ART. T141

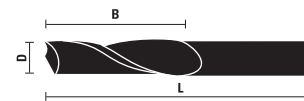

- Right-hand rotation with "UP CUT SPIRAL"

- To be used on machining centres, CNC routers and point to point machines

| RH rotation | D | B | L | Z |
|-------------|-----|----|-----|---|
| T141.030.R | 3 | 12 | 50 | 1 |
| T141.040.R | 4 | 12 | 50 | 1 |
| T141.050.R | 5 | 17 | 50 | 1 |
| T141.060.R | 6 | 17 | 60 | 1 |
| T141.061.R | 6 | 27 | 60 | 1 |
| T141.064.R | 6,4 | 28 | 60 | 1 |
| T141.080.R | 8 | 22 | 80 | 1 |
| T141.081.R | 8 | 32 | 80 | 1 |
| T141.100.R | 10 | 32 | 80 | 1 |
| T141.101.R | 10 | 42 | 100 | 1 |
| T141.120.R | 12 | 32 | 80 | 1 |
| T141.121.R | 12 | 42 | 100 | 1 |

Router bits with diameter from 12 mm, are produced with shank for Seeger retaining rings



SOLID CARBIDE SPIRAL CUTTERS, FINISH STYLE Z=1

ART. T141

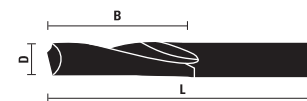

- Left-hand rotation with "DOWN CUT SPIRAL"

- To be used on machining centres, CNC routers and point to point machines

| LH rotation | D | B | L | Z |
|-------------|----|----|-----|---|
| T141.061.L | 6 | 27 | 60 | 1 |
| T141.080.L | 8 | 22 | 80 | 1 |
| T141.081.L | 8 | 32 | 80 | 1 |
| T141.100.L | 10 | 32 | 100 | 1 |

SOLID CARBIDE SPIRAL CUTTERS, FINISH STYLE Z=2

ART. T142

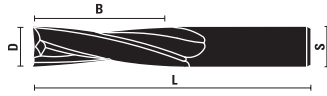

Excellent finish on bottom side



- Right-hand rotation with "UP CUT SPIRAL"
- To be used on machining centres, CNC routers and point to point machines

| RH rotation | D | B | L | Z |
|-----------------------|-------|--------|--------|---|
| T142.030.R | 3 | 12 | 50 | 2 |
| T142.032.R NEW | 1/8" | 1/2" | 2" | 2 |
| T142.040.R | 4 | 12 | 50 | 2 |
| T142.048.R NEW | 3/16" | 3/4" | 2" | 2 |
| T142.050.R | 5 | 17 | 50 | 2 |
| T142.060.R | 6 | 17 | 60 | 2 |
| T142.061.R | 6 | 27 | 60 | 2 |
| T142.064.R NEW | 1/4" | 3/4" | 2" | 2 |
| T142.065.R NEW | 1/4" | 1-1/4" | 2-1/2" | 2 |
| T142.079.R NEW | 5/16" | 1" | 2-1/2" | 2 |
| T142.080.R | 8 | 22 | 80 | 2 |
| T142.081.R | 8 | 35 | 80 | 2 |
| T142.095.R NEW | 3/8" | 1-1/4" | 3" | 2 |
| T142.100.R | 10 | 35 | 80 | 2 |
| T142.101.R | 10 | 45 | 100 | 2 |
| T142.110.R | 11 | 35 | 80 | 2 |
| T142.111.R | 11 | 45 | 100 | 2 |
| T142.120.R | 12 | 35 | 80 | 2 |
| T142.121.R | 12 | 45 | 100 | 2 |
| T142.122.R | 12 | 55 | 100 | 2 |
| T142.127.R NEW | 1/2" | 1-1/4" | 3" | 2 |
| T142.128.R NEW | 1/2" | 2" | 4" | 2 |
| T142.140.R | 14 | 45 | 100 | 2 |
| T142.141.R | 14 | 55 | 100 | 2 |
| T142.142.R | 14 | 80 | 140 | 2 |
| T142.160.R | 16 | 45 | 100 | 2 |
| T142.161.R | 16 | 55 | 100 | 2 |
| T142.162.R | 16 | 72 | 120 | 2 |
| T142.180.R | 18 | 55 | 100 | 2 |
| T142.181.R | 18 | 72 | 120 | 2 |
| T142.182.R | 18 | 102 | 150 | 2 |
| T142.200.R | 20 | 55 | 100 | 2 |
| T142.201.R | 20 | 72 | 120 | 2 |
| T142.202.R | 20 | 102 | 150 | 2 |

Router bits with diameter from 12 mm to 20 mm, are produced with shank for Seeger retaining rings



HOW TO DETERMINE THE FEEDING SPEED RELATING TO THE DIAMETER:

- Referring to item T142 with right hand rotation (UP CUT STYLE), Z=2
- RPM 18.000

Hard wood

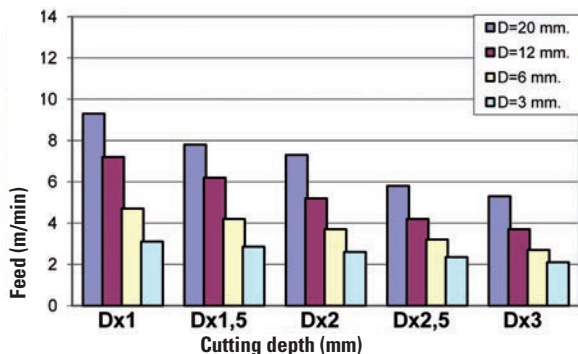

Soft wood

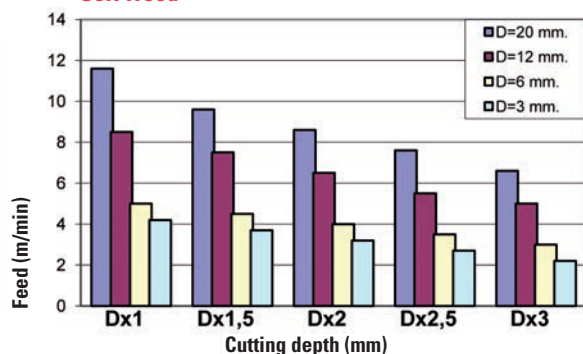

SOLID CARBIDE SPIRAL CUTTERS, FINISH STYLE Z=2

ART. T142

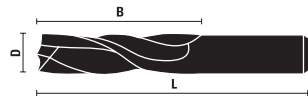

Excellent finish on panel top side



- Left-hand rotation with "DOWN CUT SPIRAL"
- To be used on machining centres, CNC routers and point to point machines

| LH rotation | D | B | L | Z |
|-------------|----|-----|-----|---|
| T142.030.L | 3 | 12 | 50 | 2 |
| T142.040.L | 4 | 12 | 50 | 2 |
| T142.060.L | 6 | 17 | 60 | 2 |
| T142.081.L | 8 | 35 | 80 | 2 |
| T142.100.L | 10 | 35 | 80 | 2 |
| T142.120.L | 12 | 35 | 90 | 2 |
| T142.140.L | 14 | 45 | 100 | 2 |
| T142.160.L | 16 | 45 | 100 | 2 |
| T142.161.L | 16 | 55 | 100 | 2 |
| T142.180.L | 18 | 55 | 115 | 2 |
| T142.182.L | 18 | 102 | 165 | 2 |
| T142.200.L | 20 | 55 | 120 | 2 |

Router bits with diameter from 12 mm to 20 mm, are produced with shank for Seeger retaining rings



SOLID CARBIDE SPIRAL CUTTERS, FINISH STYLE Z=3

ART. T143

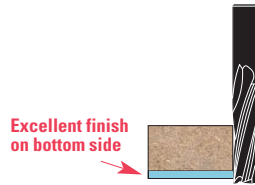
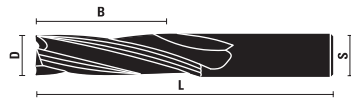

- Right-hand rotation with "UP CUT SPIRAL"
- To be used on machining centres, CNC routers and point to point machines

| RH rotation | D | B | L | Z |
|-------------|----|-----|-----|---|
| T143.080.R | 8 | 22 | 80 | 3 |
| T143.081.R | 8 | 35 | 80 | 3 |
| T143.100.R | 10 | 35 | 80 | 3 |
| T143.101.R | 10 | 45 | 100 | 3 |
| T143.120.R | 12 | 35 | 80 | 3 |
| T143.121.R | 12 | 45 | 100 | 3 |
| T143.122.R | 12 | 55 | 100 | 3 |
| T143.140.R | 14 | 45 | 100 | 3 |
| T143.141.R | 14 | 55 | 100 | 3 |
| T143.160.R | 16 | 45 | 100 | 3 |
| T143.161.R | 16 | 55 | 100 | 3 |
| T143.162.R | 16 | 72 | 120 | 3 |
| T143.180.R | 18 | 55 | 100 | 3 |
| T143.181.R | 18 | 72 | 120 | 3 |
| T143.182.R | 18 | 102 | 150 | 3 |
| T143.200.R | 20 | 55 | 100 | 3 |
| T143.201.R | 20 | 72 | 120 | 3 |
| T143.202.R | 20 | 102 | 150 | 3 |
| T143.250.R | 25 | 102 | 150 | 3 |

Router bits with diameter from 12 mm to 25 mm, are produced with shank for Seeger retaining rings



SOLID CARBIDE SPIRAL CUTTERS, FINISH STYLE Z=3

ART. T143

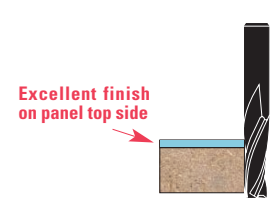
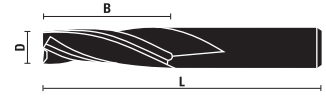

- Left-hand rotation with "DOWN CUT SPIRAL"
- To be used on machining centres, CNC routers and point to point machines

| LH rotation | D | B | L | Z |
|-------------|----|----|-----|---|
| T143.081.L | 8 | 35 | 80 | 3 |
| T143.101.L | 10 | 45 | 100 | 3 |
| T143.120.L | 12 | 35 | 85 | 3 |
| T143.160.L | 16 | 45 | 100 | 3 |
| T143.180.L | 18 | 55 | 115 | 3 |
| T143.200.L | 20 | 55 | 115 | 3 |
| T143.201.L | 20 | 72 | 130 | 3 |

Router bits with diameter from 12 mm to 20 mm, are produced with shank for Seeger retaining rings



THREE POINT DIGITAL CALIPER

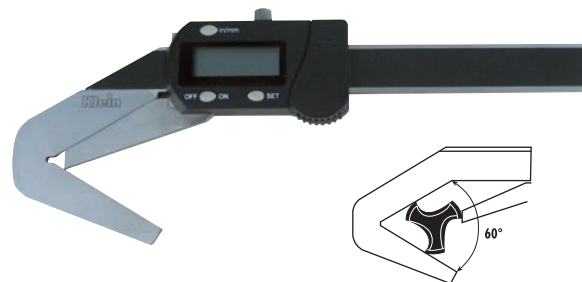

See page 15.03 for further information

HOW TO DETERMINE THE FEEDING SPEED RELATING TO THE DIAMETER:

- Referring to item T143 with right hand rotation (UP CUT STYLE), Z=3
- RPM 18.000

Hard wood

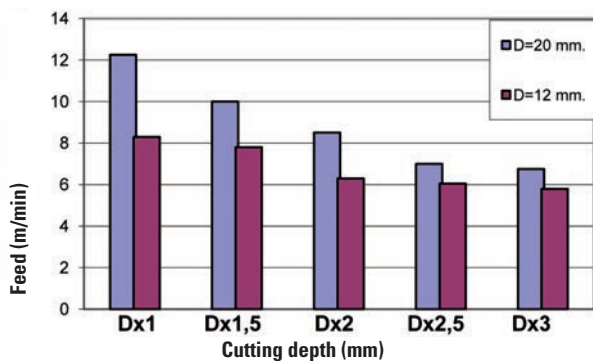

Soft wood

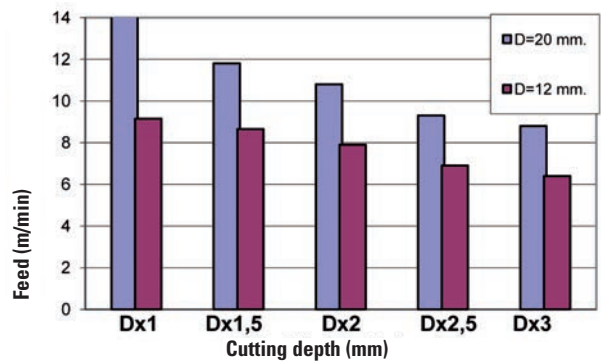

**SOLID CARBIDE SPIRAL CUTTERS,
ROUGHING STYLE Z=3**

ART. T144

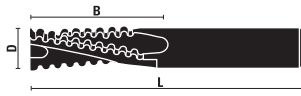

- Right-hand rotation with "UP-CUT STYLE"
- Chip-breaker execution
- To be used on machining centres, CNC routers and point to point machines
- Suitable for roughing, they guarantee a high feed rate

| RH rotation | D | B | L | Z |
|-----------------------|------|--------|--------|---|
| T144.080.R | 8 | 22 | 80 | 3 |
| T144.081.R | 8 | 35 | 80 | 3 |
| T144.095.R NEW | 3/8" | 1" | 3" | 3 |
| T144.100.R | 10 | 35 | 80 | 3 |
| T144.101.R | 10 | 45 | 100 | 3 |
| T144.120.R | 12 | 35 | 80 | 3 |
| T144.121.R | 12 | 45 | 100 | 3 |
| T144.122.R | 12 | 55 | 100 | 3 |
| T144.123.R | 12 | 42 | 90 | 3 |
| T144.127.R NEW | 1/2" | 1-1/8" | 3" | 3 |
| T144.128.R NEW | 1/2" | 1-5/8" | 3-1/2" | 3 |
| T144.140.R | 14 | 45 | 100 | 3 |
| T144.141.R | 14 | 55 | 100 | 3 |
| T144.142.R | 14 | 58 | 110 | 3 |
| T144.159.R NEW | 5/8" | 2" | 4" | 3 |
| T144.160.R | 16 | 45 | 100 | 3 |
| T144.161.R | 16 | 55 | 100 | 3 |
| T144.162.R | 16 | 72 | 120 | 3 |
| T144.163.R | 16 | 62 | 110 | 3 |
| T144.180.R | 18 | 55 | 100 | 3 |
| T144.181.R | 18 | 72 | 120 | 3 |
| T144.182.R | 18 | 102 | 150 | 3 |
| T144.191.R NEW | 3/4" | 2" | 4" | 3 |
| T144.200.R | 20 | 55 | 100 | 3 |
| T144.201.R | 20 | 72 | 120 | 3 |
| T144.202.R | 20 | 102 | 150 | 3 |
| T144.250.R | 25 | 102 | 150 | 3 |

Router bits with diameter from 12 mm to 25 mm, are produced with shank for Seeger retaining rings



**HOW TO DETERMINE THE FEEDING SPEED
RELATING TO THE DIAMETER:**

- Referring to item T144 with right hand rotation (UP CUT STYLE), Z=3
- RPM 18.000

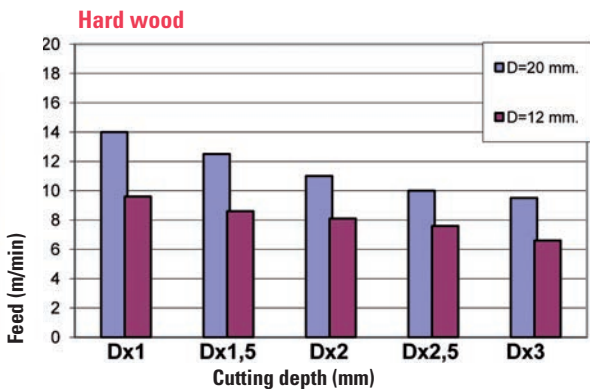

**SOLID CARBIDE SPIRAL CUTTERS,
ROUGHING STYLE Z=3**

ART. T144

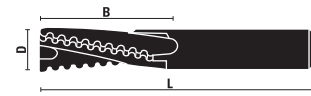

- Left-hand rotation with "DOWN-CUT STYLE"
- Chip-breaker execution
- To be used on machining centres, CNC routers and point to point machines
- Suitable for roughing, they guarantee a high feed rate

| LH rotation | D | B | L | Z |
|-------------|----|----|-----|---|
| T144.081.L | 8 | 35 | 80 | 3 |
| T144.100.L | 10 | 35 | 80 | 3 |
| T144.121.L | 12 | 45 | 100 | 3 |
| T144.122.L | 12 | 55 | 105 | 3 |
| T144.141.L | 14 | 55 | 110 | 3 |
| T144.160.L | 16 | 45 | 100 | 3 |
| T144.161.L | 16 | 55 | 110 | 3 |
| T144.162.L | 16 | 72 | 125 | 3 |
| T144.180.L | 18 | 55 | 115 | 3 |
| T144.200.L | 20 | 55 | 115 | 3 |

Router bits with diameter from 12 mm to 20 mm, are produced with shank for Seeger retaining rings

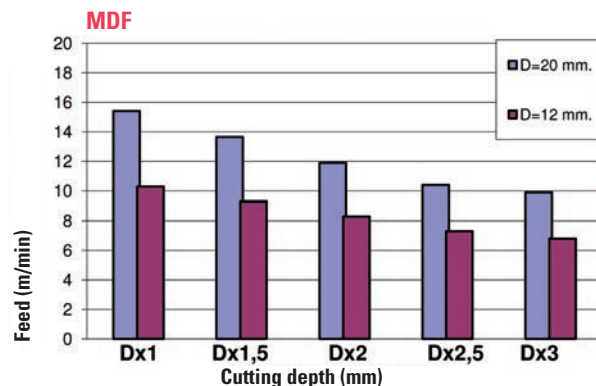
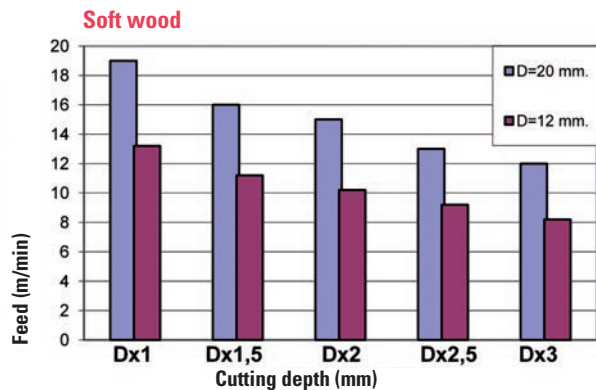

SOLID CARBIDE SPIRAL CUTTERS Z=3

ART. T146 - T147

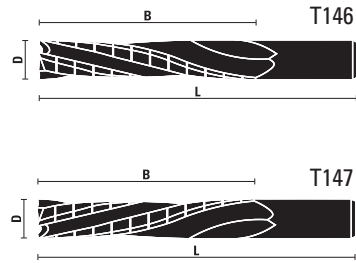

- Right-hand rotation with "UP CUT SPIRAL" (art. T146)
- Left-hand rotation with "UP CUT SPIRAL" (art. T147)
- Discontinuous cutting edge
- To be used on machining centres, CNC routers and point to point machines

| RH rotation | D | B | L | Z |
|-------------|----|-----|-----|---|
| T146.250.R | 25 | 140 | 200 | 3 |

| LH rotation | D | B | L | Z |
|-------------|----|-----|-----|---|
| T147.250.L | 25 | 140 | 200 | 3 |

Router bits with diameter from 25 mm, are produced with shank for Seeger retaining rings



SOLID CARBIDE SPIRAL CUTTERS, FINISH STYLE Z=1

ART. T151

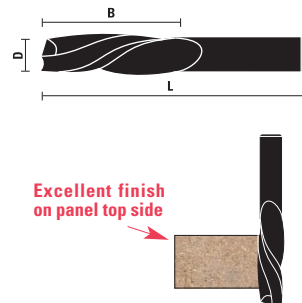

- Right-hand rotation with "DOWN CUT SPIRAL"
- To be used on machining centres, CNC routers and point to point machines

| RH rotation | D | B | L | Z |
|-------------|----|----|-----|---|
| T151.030.R | 3 | 12 | 50 | 1 |
| T151.040.R | 4 | 12 | 50 | 1 |
| T151.050.R | 5 | 17 | 50 | 1 |
| T151.060.R | 6 | 17 | 70 | 1 |
| T151.061.R | 6 | 27 | 70 | 1 |
| T151.080.R | 8 | 22 | 80 | 1 |
| T151.081.R | 8 | 32 | 80 | 1 |
| T151.100.R | 10 | 32 | 80 | 1 |
| T151.101.R | 10 | 42 | 100 | 1 |
| T151.120.R | 12 | 32 | 90 | 1 |
| T151.121.R | 12 | 42 | 100 | 1 |
| T151.122.R | 12 | 52 | 110 | 1 |

Router bits with diameter from 12 mm to 20 mm, are produced with shank for Seeger retaining rings



SOLID CARBIDE SPIRAL CUTTERS, FINISH STYLE Z=1

ART. T151

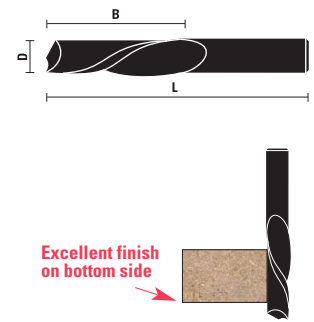

- Left-hand rotation with "UP CUT SPIRAL"
- To be used on machining centres, CNC routers and point to point machines

| LH rotation | D | B | L | Z |
|-------------|---|----|----|---|
| T151.040.L | 4 | 12 | 50 | 1 |
| T151.061.L | 6 | 27 | 60 | 1 |

SOLID CARBIDE SPIRAL CUTTERS, FINISH STYLE Z=2

ART. T152

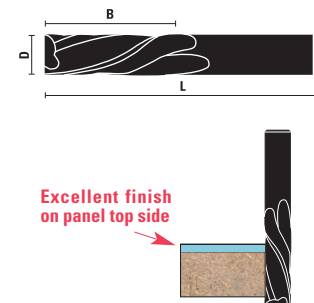

- Right-hand rotation with "DOWN CUT SPIRAL"
- To be used on machining centres, CNC routers and point to point machines

| RH rotation | D | B | L | Z |
|----------------|-------|--------|--------|---|
| T152.030.R | 3 | 12 | 50 | 2 |
| T152.032.R NEW | 1/8" | 1/2" | 2" | 2 |
| T152.040.R | 4 | 12 | 50 | 2 |
| T152.048.R NEW | 3/16" | 3/4" | 2" | 2 |
| T152.050.R | 5 | 17 | 50 | 2 |
| T152.060.R | 6 | 17 | 70 | 2 |
| T152.061.R | 6 | 27 | 70 | 2 |
| T152.064.R NEW | 1/4" | 3/4" | 2" | 2 |
| T152.065.R NEW | 1/4" | 1-1/4" | 2-1/2" | 2 |
| T152.079.R NEW | 5/16" | 1" | 2-1/2" | 2 |
| T152.080.R | 8 | 22 | 80 | 2 |
| T152.081.R | 8 | 35 | 80 | 2 |
| T152.095.R NEW | 3/8" | 1-1/4" | 3" | 2 |
| T152.100.R | 10 | 35 | 80 | 2 |
| T152.101.R | 10 | 45 | 100 | 2 |
| T152.110.R | 11 | 35 | 80 | 2 |
| T152.111.R | 11 | 45 | 100 | 2 |
| T152.120.R | 12 | 35 | 90 | 2 |
| T152.121.R | 12 | 45 | 100 | 2 |
| T152.122.R | 12 | 55 | 110 | 2 |
| T152.127.R NEW | 1/2" | 1-1/4" | 3" | 2 |
| T152.128.R NEW | 1/2" | 2" | 4" | 2 |
| T152.141.R | 14 | 55 | 110 | 2 |
| T152.160.R | 16 | 45 | 100 | 2 |
| T152.161.R | 16 | 55 | 110 | 2 |
| T152.180.R | 18 | 55 | 115 | 2 |
| T152.181.R | 18 | 72 | 130 | 2 |
| T152.200.R | 20 | 55 | 115 | 2 |
| T152.201.R | 20 | 72 | 130 | 2 |

SOLID CARBIDE SPIRAL CUTTERS, FINISH STYLE Z=2

ART. T152

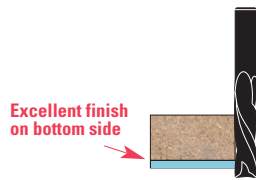
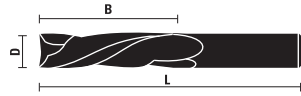

- Left-hand rotation with "UP CUT SPIRAL"

- To be used on machining centres, CNC routers and point to point machines

| LH rotation | D | B | L | Z |
|-------------|----|----|-----|---|
| T152.040.L | 4 | 12 | 50 | 2 |
| T152.060.L | 6 | 17 | 60 | 2 |
| T152.061.L | 6 | 27 | 60 | 2 |
| T152.080.L | 8 | 22 | 80 | 2 |
| T152.100.L | 10 | 35 | 80 | 2 |
| T152.120.L | 12 | 35 | 80 | 2 |
| T152.121.L | 12 | 45 | 100 | 2 |
| T152.141.L | 14 | 55 | 110 | 2 |
| T152.161.L | 16 | 55 | 110 | 2 |
| T152.181.L | 18 | 72 | 120 | 2 |
| T152.200.L | 20 | 55 | 100 | 2 |
| T152.201.L | 20 | 72 | 120 | 2 |

Router bits with diameter from 12 mm to 20 mm, are produced with shank for Seeger retaining rings



SOLID CARBIDE SPIRAL CUTTERS, FINISH STYLE Z=3

ART. T153

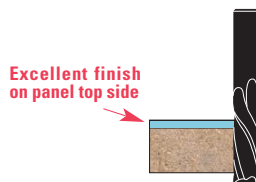
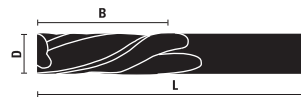

- Right-hand rotation with "DOWN CUT SPIRAL"

- To be used on machining centres, CNC routers and point to point machines

| RH rotation | D | B | L | Z |
|-------------|----|----|-----|---|
| T153.081.R | 8 | 35 | 80 | 3 |
| T153.100.R | 10 | 35 | 80 | 3 |
| T153.101.R | 10 | 45 | 100 | 3 |
| T153.120.R | 12 | 35 | 85 | 3 |
| T153.122.R | 12 | 55 | 105 | 3 |
| T153.140.R | 14 | 45 | 100 | 3 |
| T153.160.R | 16 | 45 | 100 | 3 |
| T153.161.R | 16 | 55 | 110 | 3 |
| T153.162.R | 16 | 72 | 125 | 3 |
| T153.180.R | 18 | 55 | 115 | 3 |
| T153.181.R | 18 | 72 | 130 | 3 |
| T153.200.R | 20 | 55 | 115 | 3 |
| T153.201.R | 20 | 72 | 130 | 3 |

Router bits with diameter from 12 mm to 20 mm, are produced with shank for Seeger retaining rings



SOLID CARBIDE SPIRAL CUTTERS, FINISH STYLE Z=3

ART. T153

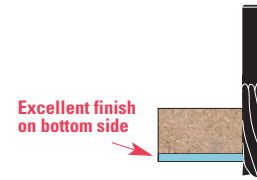

- Left-hand rotation with "UP CUT SPIRAL"

- To be used on machining centres, CNC routers and point to point machines

| LH rotation | D | B | L | Z |
|-------------|----|----|-----|---|
| T153.081.L | 8 | 35 | 80 | 3 |
| T153.100.L | 10 | 35 | 80 | 3 |
| T153.101.L | 10 | 45 | 100 | 3 |
| T153.120.L | 12 | 35 | 80 | 3 |
| T153.122.L | 12 | 55 | 100 | 3 |
| T153.140.L | 14 | 45 | 100 | 3 |
| T153.160.L | 16 | 45 | 100 | 3 |
| T153.161.L | 16 | 55 | 110 | 3 |
| T153.200.L | 20 | 55 | 100 | 3 |
| T153.201.L | 20 | 72 | 120 | 3 |

Router bits with diameter from 12 mm to 20 mm, are produced with shank for Seeger retaining rings



SOLID CARBIDE SPIRAL CUTTERS, ROUGHING STYLE Z=3

ART. T154

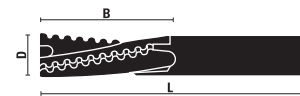

- Right-hand rotation with "DOWN CUT SPIRAL"

- Chip-breaker execution

- To be used on machining centres, CNC routers and point to point machines

- Suitable for roughing, they guarantee a high feed rate

| RH rotation | D | B | L | Z |
|-----------------------|------|--------|--------|---|
| T154.080.R | 8 | 22 | 80 | 3 |
| T154.081.R | 8 | 35 | 80 | 3 |
| T154.095.R NEW | 3/8" | 1" | 3" | 3 |
| T154.100.R | 10 | 35 | 80 | 3 |
| T154.101.R | 10 | 45 | 100 | 3 |
| T154.120.R | 12 | 35 | 83 | 3 |
| T154.121.R | 12 | 45 | 100 | 3 |
| T154.122.R | 12 | 55 | 105 | 3 |
| T154.127.R NEW | 1/2" | 1-1/8" | 3" | 3 |
| T154.128.R NEW | 1/2" | 1-5/8" | 3-1/2" | 3 |
| T154.140.R | 14 | 45 | 100 | 3 |
| T154.159.R NEW | 5/8" | 2" | 4" | 3 |
| T154.160.R | 16 | 45 | 110 | 3 |
| T154.161.R | 16 | 55 | 110 | 3 |
| T154.162.R | 16 | 72 | 125 | 3 |
| T154.180.R | 18 | 55 | 115 | 3 |
| T154.181.R | 18 | 72 | 130 | 3 |
| T154.191.R NEW | 3/4" | 2" | 4" | 3 |
| T154.200.R | 20 | 55 | 115 | 3 |
| T154.201.R | 20 | 72 | 130 | 3 |
| T154.202.R | 20 | 102 | 160 | 3 |

Router bits with diameter from 12 mm to 20 mm, are produced with shank for Seeger retaining rings



SOLID CARBIDE SPIRAL CUTTERS, ROUGHING STYLE Z=3

ART. T154

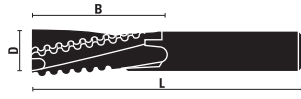

- Left-hand rotation with "UP CUT SPIRAL"
- Chip-breaker execution
- To be used on machining centres, CNC routers and point to point machines
- Suitable for roughing, they guarantee a high feed rate

| LH rotation | D | B | L | Z |
|-------------|----|-----|-----|---|
| T154.081.L | 8 | 35 | 80 | 3 |
| T154.100.L | 10 | 35 | 80 | 3 |
| T154.120.L | 12 | 35 | 80 | 3 |
| T154.122.L | 12 | 55 | 100 | 3 |
| T154.140.L | 14 | 45 | 100 | 3 |
| T154.160.L | 16 | 45 | 100 | 3 |
| T154.161.L | 16 | 55 | 110 | 3 |
| T154.180.L | 18 | 55 | 100 | 3 |
| T154.200.L | 20 | 55 | 100 | 3 |
| T154.201.L | 20 | 72 | 120 | 3 |
| T154.250.L | 25 | 155 | 220 | 3 |

SOLID CARBIDE COMPRESSION CUTTERS Z=1+1

ART. T155

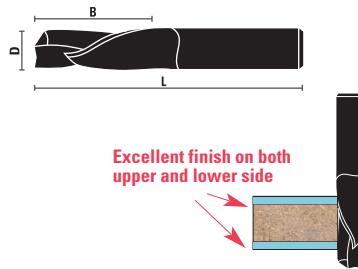

- Right-hand rotation with double flute, compression spiral
- To be used on machining centres, CNC routers and point to point machines

| RH rotation | D | B | L | Z |
|-------------|------|----|-----|-----|
| T155.061.R | 6 | 27 | 60 | 1+1 |
| T155.080.R | 8 | 22 | 80 | 1+1 |
| T155.081.R | 8 | 32 | 80 | 1+1 |
| T155.100.R | 10 | 32 | 80 | 1+1 |
| T155.101.R | 10 | 42 | 100 | 1+1 |
| T155.120.R | 12 | 42 | 100 | 1+1 |
| T155.121.R | 12 | 52 | 100 | 1+1 |
| T155.127.R | 12,7 | 32 | 78 | 1+1 |
| T155.161.R | 16 | 52 | 100 | 1+1 |

SOLID CARBIDE COMPRESSION CUTTERS Z=1+1

ART. T155

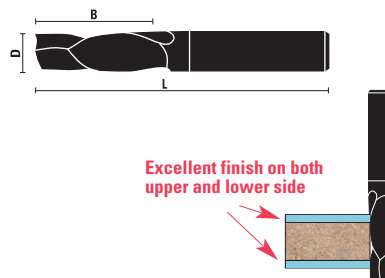

- Left-hand rotation with double flute, compression spiral
- To be used on machining centres, CNC routers and point to point machines

| LH rotation | D | B | L | Z |
|-------------|----|----|-----|-----|
| T155.061.L | 6 | 27 | 60 | 1+1 |
| T155.081.L | 8 | 32 | 80 | 1+1 |
| T155.100.L | 10 | 32 | 80 | 1+1 |
| T155.120.L | 12 | 42 | 100 | 1+1 |

SOLID CARBIDE SPIRAL CUTTERS Z=2 - Z=3

ART. T157

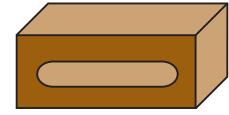

- Right-hand rotation with "UP CUT SPIRAL"
- Chip-breaker execution
- For locks and slot mortising

| RH rotation | D | B1 | B | L | S | Z |
|-------------|----|----|-----|-----|-------|---|
| T157.140.R | 14 | 20 | 95 | 155 | 14x45 | 2 |
| T157.141.R | 14 | 45 | 95 | 150 | 14x45 | 3 |
| T157.160.R | 16 | 25 | 115 | 175 | 16x45 | 2 |
| T157.161.R | 16 | 45 | 95 | 140 | 16x45 | 2 |
| T157.162.R | 16 | 50 | 100 | 150 | 16x45 | 3 |
| T157.180.R | 18 | 25 | 115 | 175 | 18x45 | 2 |
| T157.181.R | 18 | 50 | 100 | 150 | 18x45 | 3 |

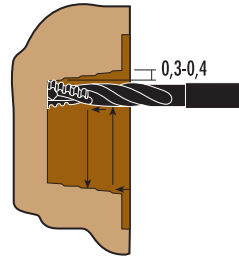

USE EXAMPLE

- Z=2/Z=3
- D= 14÷18 mm: RPM 12.000-20.000
- Stepwise processing 0,3-0,4 mm
- Can work deeply and have excellent chip evacuation

Router bits with diameter from 14 mm to 18 mm, are produced with shank for Seeger retaining rings



SOLID CARBIDE SPIRAL CUTTERS Z=3 FOR LOCKS

ART. T177 - T178



- Without chip-breaker
- For locks and slot mortising
- T177.160.R right rotation and right hand twist (positive/up cut style)
- T177.160.L left rotation and left hand twist (positive/up cut style)
- T178.160.R right rotation and left hand twist (negative/down cut style)

| RH rotation | LH rotation | D | B1 | B | L | S | Z |
|-------------|-------------|----|----|-----|-----|-------|---|
| T177.160.R | T177.160.L | 16 | 50 | 100 | 150 | 16x45 | 3 |
| T178.160.R | | 16 | 50 | 100 | 150 | 16x45 | 3 |

Router bits with diameter from 16 mm, are produced with shank for Seeger retaining rings



SOLID CARBIDE COMPRESSION CUTTERS Z=2+2

ART. T156



Excellent finish on both upper and lower side

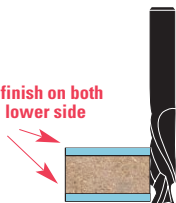

- Right-hand rotation with double flute, compression spiral
- To be used on machining centres, CNC routers and point to point machines

| RH rotation | D | B | L | Z |
|-------------|------|-----|-----|-----|
| T156.080.R | 8 | 22 | 80 | 2+2 |
| T156.081.R | 8 | 32 | 80 | 2+2 |
| T156.100.R | 10 | 32 | 80 | 2+2 |
| T156.101.R | 10 | 42 | 100 | 2+2 |
| T156.120.R | 12 | 42 | 100 | 2+2 |
| T156.121.R | 12 | 52 | 110 | 2+2 |
| T156.127.R | 12,7 | 32 | 78 | 2+2 |
| T156.140.R | 14 | 42 | 100 | 2+2 |
| T156.141.R | 14 | 52 | 110 | 2+2 |
| T156.160.R | 16 | 42 | 100 | 2+2 |
| T156.161.R | 16 | 52 | 110 | 2+2 |
| T156.162.R | 16 | 72 | 130 | 2+2 |
| T156.180.R | 18 | 52 | 115 | 2+2 |
| T156.181.R | 18 | 72 | 135 | 2+2 |
| T156.182.R | 18 | 102 | 165 | 2+2 |
| T156.200.R | 20 | 52 | 115 | 2+2 |
| T156.201.R | 20 | 72 | 135 | 2+2 |

Router bits with diameter from 12 mm to 20 mm, are produced with shank for Seeger retaining rings



HOW TO DETERMINE THE FEEDING SPEED RELATING TO THE DIAMETER:

- Referring to item T156 with double flute, compression spiral, Z=2+2.
- RPM 18.000

Hard wood

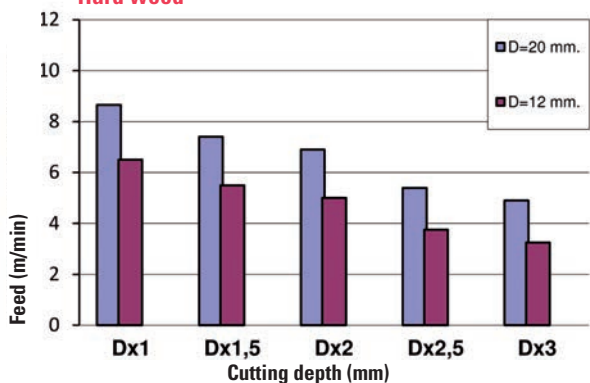

Soft wood

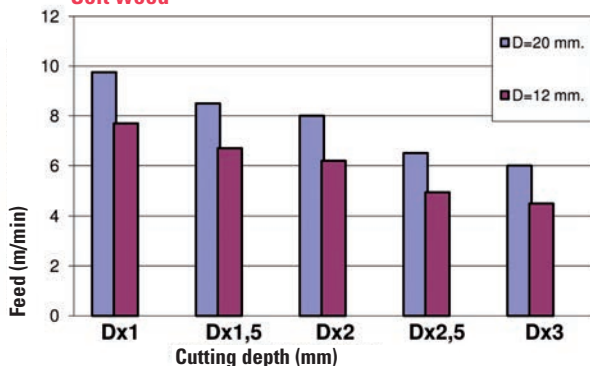

SOLID CARBIDE COMPRESSION CUTTERS Z=2+2

ART. T156

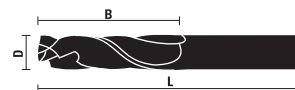

Excellent finish on both upper and lower side

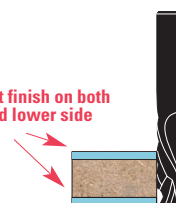

- Left-hand rotation with double flute, compression spiral
- To be used on machining centres, CNC routers and point to point machines

| RH rotation | D | B | L | Z |
|-------------|----|----|-----|-----|
| T156.080.L | 8 | 22 | 80 | 2+2 |
| T156.081.L | 8 | 32 | 80 | 2+2 |
| T156.101.L | 10 | 42 | 100 | 2+2 |
| T156.120.L | 12 | 42 | 100 | 2+2 |
| T156.121.L | 12 | 52 | 105 | 2+2 |
| T156.161.L | 16 | 52 | 110 | 2+2 |
| T156.180.L | 18 | 52 | 115 | 2+2 |
| T156.200.L | 20 | 52 | 115 | 2+2 |
| T156.201.L | 20 | 72 | 135 | 2+2 |

Router bits with diameter from 12 mm to 20 mm, are produced with shank for Seeger retaining rings



SOLID CARBIDE MORTISE COMPRESSION Z=2+2

ART. T156.M



Excellent finish on both upper and lower side

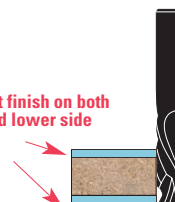

- Right-hand rotation
- Excellent finish on both upper and lower side of the panel
- These tools have a shorter up-cut section compared to standard compression bits. They are suitable for mortising, grooving, routing and dado
- For softwood and hardwood, chipboard, MDF, HF, double-sided melamine and laminated, plywood, plastic coated, mineral materials (CORIAN® ecc.)
- To be used on machining centres, CNC routers and point to point machines

| RH rotation | D | B | L | S |
|-----------------|------|--------|--------|------|
| T156.095.RM NEW | 3/8" | 7/8" | 3" | 3/8" |
| T156.096.RM NEW | 3/8" | 1-1/4" | 3" | 3/8" |
| T156.127.RM NEW | 1/2" | 7/8" | 3" | 1/2" |
| T156.128.RM NEW | 1/2" | 1-1/4" | 3" | 1/2" |
| T156.129.RM NEW | 1/2" | 1-5/8" | 3-1/2" | 1/2" |

SOLID CARBIDE COMPRESSION CUTTERS Z=3+3

ART. T356

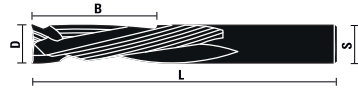

Excellent finish on both upper and lower side

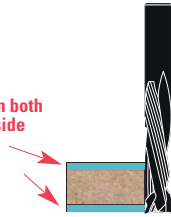

- Right-hand rotation
- To be used on machining centres, CNC routers and point to point machines
- Excellent finish on both upper and lower side of the panel
- For softwood and hardwood, chipboard, MDF, HF, plywood, plastic coated, mineral materials (CORIAN® ecc.)

| RH rotation | D | B | L | Z |
|-----------------------|----|----|-----|-----|
| T356.080.R NEW | 8 | 22 | 70 | 3+3 |
| T356.100.R NEW | 10 | 22 | 70 | 3+3 |
| T356.101.R NEW | 10 | 32 | 70 | 3+3 |
| T356.120.R NEW | 12 | 32 | 80 | 3+3 |
| T356.121.R NEW | 12 | 42 | 100 | 3+3 |
| T356.160.R NEW | 16 | 42 | 100 | 3+3 |
| T356.161.R NEW | 16 | 52 | 100 | 3+3 |

SOLID CARBIDE MORTISE COMPRESSION Z=3+3

ART. T356.M

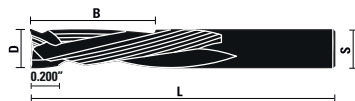

Excellent finish on both upper and lower side

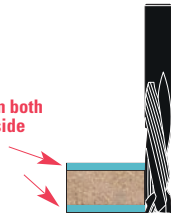

- Right-hand rotation
- Excellent finish on both upper and lower side of the panel
- These tools have a shorter up-cut section compared to standard compression bits. They are suitable for mortising, grooving, routing and dado
- For softwood and hardwood, chipboard, MDF, HF, double-sided melamine and laminated, plywood, plastic coated, mineral materials (CORIAN® ecc.)
- To be used on machining centres, CNC routers and point to point machines

| RH rotation | D | B | L | Z |
|------------------------|------|--------|----|------|
| T356.095.RM NEW | 3/8" | 7/8" | 3" | 3/8" |
| T356.096.RM NEW | 3/8" | 1-1/4" | 3" | 3/8" |
| T356.127.RM NEW | 1/2" | 7/8" | 3" | 1/2" |
| T356.128.RM NEW | 1/2" | 1-1/4" | 3" | 1/2" |

SOLID CARBIDE SPIRAL CUTTERS Z=2

ART. T158

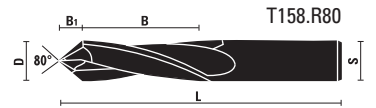
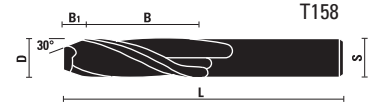

- Right-hand rotation with "UP CUT SPIRAL"
- For spy holes
- For boring and routing

| RH rotation | D | B1 | B | L | S | Z |
|--------------|----|-----|----|-----|----|---|
| T158.140.R | 14 | 8 | 42 | 100 | 14 | 2 |
| T158.160.R | 16 | 9 | 52 | 120 | 16 | 2 |
| T158.180.R | 18 | 10 | 52 | 120 | 18 | 2 |
| T158.200.R | 20 | 11 | 52 | 120 | 20 | 2 |
| T158.080.R80 | 8 | 4,8 | 38 | 80 | 8 | 2 |
| T158.100.R80 | 10 | 6 | 46 | 100 | 10 | 2 |
| T158.120.R80 | 12 | 7,2 | 50 | 110 | 12 | 2 |
| T158.160.R80 | 16 | 9,6 | 52 | 120 | 16 | 2 |

Router bits with diameter from 12 mm to 20 mm, are produced with shank for Seeger retaining rings



SOLID CARBIDE SPIRAL CUTTERS Z=2

ART. T159

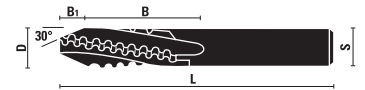

- Right-hand rotation with "UP CUT SPIRAL"
- Chip-breaker execution
- For spyholes on doors
- Through holes cutting

| RH rotation | D | B1 | B | L | S | Z |
|-------------|----|----|----|-----|----|---|
| T159.160.R | 16 | 9 | 52 | 120 | 16 | 2 |
| T159.200.R | 20 | 11 | 52 | 120 | 20 | 2 |

Router bits with diameter from 16 mm to 20 mm, are produced with shank for Seeger retaining rings



SOLID CARBIDE SPIRAL CUTTERS, FINISH STYLE S=6 Z=2

ART. T160

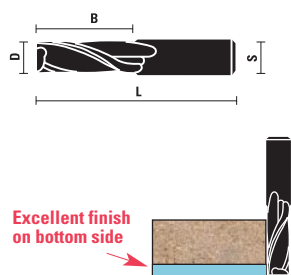

- Can also be used on portable routers
 - Right-hand rotation with "UP CUT SPIRAL"

| RH rotation | D | B | L | S | Z |
|-------------|-----|----|----|---|---|
| T160.030.R | 3 | 12 | 60 | 6 | 2 |
| T160.035.R | 3,5 | 14 | 60 | 6 | 2 |
| T160.040.R | 4 | 14 | 60 | 6 | 2 |
| T160.045.R | 4,5 | 16 | 60 | 6 | 2 |
| T160.050.R | 5 | 17 | 60 | 6 | 2 |

SOLID CARBIDE SPIRAL CUTTERS, FINISH STYLE S=6 Z=2

ART. T161

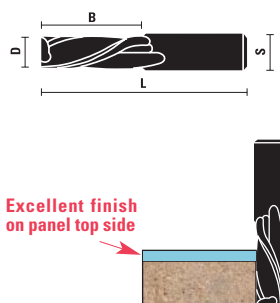

- Can also be used on portable routers
 - Right-hand rotation with "DOWN CUT SPIRAL"

| Rotaz. DX | D | B | L | S | Z |
|------------|-----|----|----|---|---|
| T161.030.R | 3 | 12 | 60 | 6 | 2 |
| T161.035.R | 3,5 | 14 | 60 | 6 | 2 |
| T161.040.R | 4 | 14 | 60 | 6 | 2 |
| T161.045.R | 4,5 | 16 | 60 | 6 | 2 |
| T161.050.R | 5 | 17 | 60 | 6 | 2 |

SOLID CARBIDE SPIRAL CUTTERS, FINISH STYLE S=8 Z=2

ART. T162

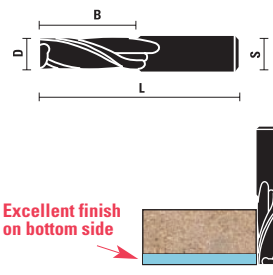

- Can also be used on portable routers
 - Right-hand rotation with "UP CUT SPIRAL"

| RH rotation | D | B | L | S | Z |
|-------------|---|----|----|---|---|
| T162.030.R | 3 | 12 | 60 | 8 | 2 |
| T162.040.R | 4 | 14 | 60 | 8 | 2 |
| T162.050.R | 5 | 17 | 60 | 8 | 2 |
| T162.060.R | 6 | 22 | 70 | 8 | 2 |
| T162.070.R | 7 | 32 | 80 | 8 | 2 |

SOLID CARBIDE SPIRAL CUTTERS, FINISH STYLE S=8 Z=2

ART. T163

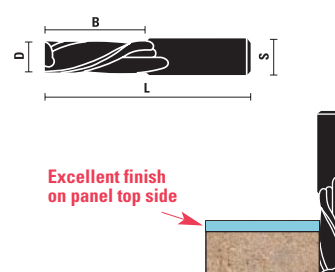

- Can also be used on portable routers
 - Right-hand rotation with "DOWN CUT SPIRAL"

| RH rotation | D | B | L | S | Z |
|-------------|---|----|----|---|---|
| T163.030.R | 3 | 12 | 60 | 8 | 2 |
| T163.040.R | 4 | 14 | 60 | 8 | 2 |
| T163.050.R | 5 | 17 | 60 | 8 | 2 |
| T163.060.R | 6 | 22 | 70 | 8 | 2 |
| T163.070.R | 7 | 32 | 80 | 8 | 2 |

SOLID CARBIDE SPIRAL CUTTERS, FINISH STYLE Z=2

ART. T164

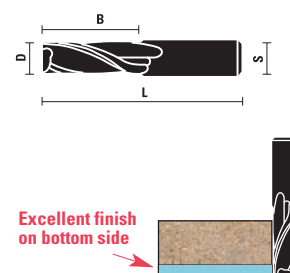

- Can also be used on portable routers
 - Right-hand rotation with "UP CUT SPIRAL"

| RH rotation | D | B | L | S | Z |
|-----------------------|-------|------|----|------|---|
| T164.032.R NEW | 1/8" | 1/2" | 2" | 1/4" | 2 |
| T164.048.R NEW | 3/16" | 3/4" | 2" | 1/4" | 2 |

visit our website

www.sistemiklein.com



HW FLUSH TRIM BITS WITH DOUBLE BALL BEARINGS Z=2

ART. T168

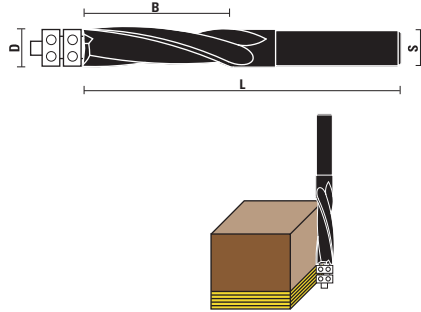

- Right-hand rotation with "UP CUT SPIRAL"
- Double ball bearings guide for **greater precision of trimming**
- Special spiral geometry which provides **better chip evacuation and smoother cuts** compared to standard flush trim bits
- For natural wood, pressed wood, veneered, laminate and melamine



| RH rotation | D | B | L | S | Z |
|-----------------------|-------------|----|-----|----|---|
| T168.127.R NEW | 12,7 (1/2") | 51 | 125 | 12 | 2 |



Z050.007.N

SOLID CARBIDE SPIRAL CUTTERS, ROUGHING STYLE Z=2

ART. T170

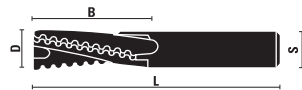

- Right-hand rotation with "UP CUT SPIRAL"
- **Chip-breaker** execution
- Z=2 for the best chip removal

| RH rotation | D | B | L | S | Z |
|-------------|----|----|----|----|---|
| T170.080.R | 8 | 35 | 80 | 8 | 2 |
| T170.100.R | 10 | 35 | 80 | 10 | 2 |
| T170.120.R | 12 | 35 | 80 | 12 | 2 |
| T170.121.R | 12 | 45 | 90 | 12 | 2 |

Router bits with diameter from 12 mm, are produced with shank for Seeger retaining rings



SOLID CARBIDE SPIRAL CUTTERS, ROUGHING STYLE Z=2

ART. T171

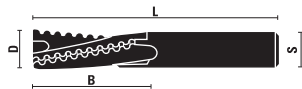

- Right-hand rotation with "DOWN CUT SPIRAL"
- **Chip-breaker** execution
- Z=2 for the best chip removal

| RH rotation | D | B | L | S | Z |
|-------------|----|----|----|----|---|
| T171.080.R | 8 | 35 | 80 | 8 | 2 |
| T171.100.R | 10 | 35 | 80 | 10 | 2 |
| T171.120.R | 12 | 35 | 80 | 12 | 2 |

Router bits with diameter from 12 mm, are produced with shank for Seeger retaining rings



SOLID CARBIDE TAPERED BALL NOSE SPIRAL BITS Z=3

ART. T173



- Right-hand rotation with "UP CUT SPIRAL"
- Specially designed for smooth 2D and 3D carving in plastic, aluminium and wood
- Use on CNC and high speed machines

| RH rotation | D | B | L | R | S |
|-----------------------|-------|----|----|-------|------|
| T173.008.R NEW | 1/32" | 1" | 3" | 1/64" | 1/4" |
| T173.009.R NEW | 0,8 | 25 | 70 | 0,4 | 6 |
| T173.016.R NEW | 1/16" | 1" | 3" | 1/32" | 1/4" |
| T173.017.R NEW | 1,6 | 25 | 70 | 0,8 | 6 |
| T173.018.R NEW | 1,6 | 30 | 80 | 0,8 | 8 |

| | | | | | |
|-----------------------|------|--------|----|-------|------|
| T173.031.R NEW | 1/8" | 1" | 3" | 1/16" | 1/4" |
| T173.032.R NEW | 1/8" | 2-1/2" | 4" | 1/16" | 1/2" |
| T173.033.R NEW | 3,17 | 30 | 70 | 1,59 | 6 |
| T173.034.R NEW | 3,17 | 50 | 90 | 1,59 | 8 |

| | | | | | |
|-----------------------|------|----|----|------|------|
| T173.064.R NEW | 1/4" | 2" | 4" | 1/8" | 1/2" |
|-----------------------|------|----|----|------|------|

SOLID CARBIDE SPIRAL CUTTERS RADIUS STYLE Z=2

ART. T175

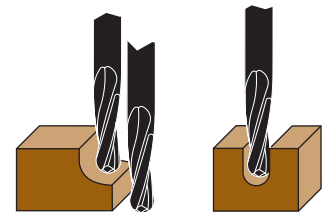
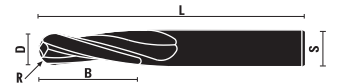

- Suitable for working plastic materials
- Right-hand rotation with "UP CUT SPIRAL"

| RH rotation | D | R | B | L | Z |
|-------------|----|-----|----|-----|---|
| T175.030.R | 3 | 1,5 | 12 | 50 | 2 |
| T175.040.R | 4 | 2 | 12 | 50 | 2 |
| T175.060.R | 6 | 3 | 22 | 60 | 2 |
| T175.080.R | 8 | 4 | 22 | 80 | 2 |
| T175.100.R | 10 | 5 | 35 | 80 | 2 |
| T175.120.R | 12 | 6 | 35 | 80 | 2 |
| T175.160.R | 16 | 8 | 55 | 100 | 2 |
| T175.180.R | 18 | 9 | 55 | 110 | 2 |
| T175.200.R | 20 | 10 | 55 | 110 | 2 |

Router bits with diameter from 12 mm, are produced with shank for Seeger retaining rings



HS ROUTER BITS FOR "HUNDEGGER" MACHINES

ART. T244

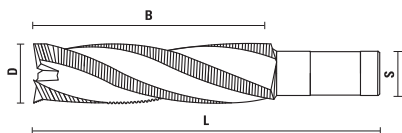

- Chip-breaker execution
- For machining lamellar beams

| RH rotation | D | B | L | S | Z |
|-------------|----|-----|-----|----|---|
| T244.400.R | 40 | 165 | 235 | 30 | 3 |
| T244.500.R | 50 | 215 | 295 | 30 | 3 |

HS CARVING BITS, PLANE STYLE

ART. T213 - T214

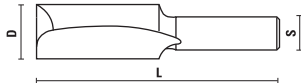

| RH rotation | LH rotation | D | L | S | Z |
|-------------|-------------|----|----|-------|---|
| T213.020.R | T213.020.L | 2 | 90 | 11x50 | 1 |
| T213.040.R | T213.040.L | 4 | 90 | 11x50 | 1 |
| T213.060.R | T213.060.L | 6 | 90 | 11x50 | 1 |
| T213.080.R | T213.080.L | 8 | 90 | 11x50 | 1 |
| T213.100.R | T213.100.L | 10 | 90 | 11x50 | 1 |
| T213.120.R | T213.120.L | 12 | 90 | 11x50 | 1 |
| T213.140.R | T213.140.L | 14 | 90 | 11x50 | 1 |
| T213.160.R | T213.160.L | 16 | 90 | 11x50 | 1 |

| | | | | | |
|------------|------------|----|----|-------|---|
| T214.100.R | T214.100.L | 10 | 90 | 11x50 | 2 |
| T214.120.R | T214.120.L | 12 | 90 | 11x50 | 2 |
| T214.140.R | T214.140.L | 14 | 90 | 11x50 | 2 |
| T214.160.R | T214.160.L | 16 | 90 | 11x50 | 2 |
| T214.180.R | T214.180.L | 18 | 90 | 11x50 | 2 |
| T214.200.R | T214.200.L | 20 | 90 | 11x50 | 2 |
| T214.220.R | T214.220.L | 22 | 90 | 11x50 | 2 |
| T214.240.R | T214.240.L | 24 | 90 | 11x50 | 2 |

HS CARVING BITS, ROUND STYLE

ART. T215 - T216

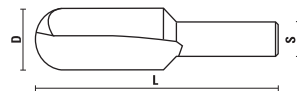

| RH rotation | LH rotation | D | L | S | Z |
|-------------|-------------|----|----|-------|---|
| T215.020.R | T215.020.L | 2 | 90 | 11x50 | 1 |
| T215.040.R | T215.040.L | 4 | 90 | 11x50 | 1 |
| T215.060.R | T215.060.L | 6 | 90 | 11x50 | 1 |
| T215.080.R | T215.080.L | 8 | 90 | 11x50 | 1 |
| T215.100.R | T215.100.L | 10 | 90 | 11x50 | 1 |
| T215.120.R | T215.120.L | 12 | 90 | 11x50 | 1 |
| T215.140.R | T215.140.L | 14 | 90 | 11x50 | 1 |
| T215.160.R | T215.160.L | 16 | 90 | 11x50 | 1 |

| | | | | | |
|------------|------------|----|----|-------|---|
| T216.100.R | T216.100.L | 10 | 90 | 11x50 | 2 |
| T216.120.R | T216.120.L | 12 | 90 | 11x50 | 2 |
| T216.140.R | T216.140.L | 14 | 90 | 11x50 | 2 |
| T216.160.R | T216.160.L | 16 | 90 | 11x50 | 2 |
| T216.180.R | T216.180.L | 18 | 90 | 11x50 | 2 |
| T216.200.R | T216.200.L | 20 | 90 | 11x50 | 2 |
| T216.220.R | T216.220.L | 22 | 90 | 11x50 | 2 |
| T216.240.R | T216.240.L | 24 | 90 | 11x50 | 2 |

KleinDIA®

A surface treatment developed for large-scale production

KleinDIA is a DLC (**Diamond-like Carbon**) anti-friction coating which allows to solve problems of tool abrasion, chip evacuation and chemical attack.

A layer of approx. 1 micron is laid on the tool surface at low temperature, thus not altering the properties of the router bit or knife.

Its high hardness is granted by both Sp2 (**Graphite**) and Sp3 (**Diamond**) carbon hybridisation.

Our several tests confirmed remarkable results on both panel working and solid wood processing.

Working plastic and aluminium without coolant is also possible thanks to a very low friction coefficient.

TECHNICAL FEATURES:

- **High hardness** Hv0,025: 2500-3100
- **Higher wear resistance** (longer working time)
- **Low frictional coefficient** (lowered working temperature)
- **Very low sticking coefficient** (Better chips evacuation)
- **Thickness:** approx. 1 micron
- **Colour:** bright black



KleinDIA is the most advantageous coating, ensuring:

- **Production increase**
- **Better finishing**
- **Less maintenance**

The surface coating **KleinDIA** can be applied on many other products giving extraordinary results depending on the type of material processed. Excellent results can be achieved processing solid wood, plywood, Plexiglas, plastic and graphitic materials.

HERE ARE SOME OF THE ITEMS WHICH ARE SUITABLE TO BE COATED WITH KleinDIA:

Solid carbide straight router bits
ART. A101/2/3 - C101/2/3 - C190 - D101/2



Page 1.07, 1.23, 2.05

Solid carbide spiral router bits
ART. T141/2/3 - T151/2/3 - T157/8/9



Page from 7.36 to 7.52, 7.54

Solid carbide dowel drills
ART. L116 - L117



Pag. 5.11

Solid carbide through-hole boring bits
ART. L134 - L135



Pag. 5.17

HW reversible knives
ART. ZB



Pag. 11.10

HS planer knives
ART. ZC 30 - ZC 35



Pag. 11.11, 11.12, 11.13



**SOLID CARBIDE SPIRAL CUTTERS FINISH STYLE
Z=2, KleinDIA COATED**

ART. T142.KD

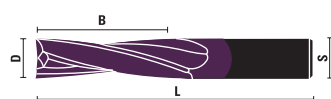

KleinDIA coating for excellent performance

Excellent finish on bottom side



- Right-hand rotation with "UP CUT SPIRAL"
- Polished and coated cutting edge for improved chip evacuation and less friction for excellent performance
- Longer tool life and greater cutting quality
- To be used on machining centres, CNC routers and point to point machines
- For **softwood and hardwood, chipboard, MDF, HF, plywood, plastic coated, mineral materials (CORIAN® ecc.)**

| RH rotation | D | B | L | Z |
|-------------------------|----|----|-----|---|
| T142.030.RKD NEW | 3 | 12 | 50 | 2 |
| T142.040.RKD NEW | 4 | 12 | 50 | 2 |
| T142.050.RKD NEW | 5 | 17 | 50 | 2 |
| T142.060.RKD NEW | 6 | 17 | 60 | 2 |
| T142.061.RKD NEW | 6 | 27 | 60 | 2 |
| T142.080.RKD NEW | 8 | 22 | 80 | 2 |
| T142.081.RKD NEW | 8 | 35 | 80 | 2 |
| T142.100.RKD NEW | 10 | 35 | 80 | 2 |
| T142.101.RKD NEW | 10 | 45 | 100 | 2 |
| T142.121.RKD NEW | 12 | 45 | 100 | 2 |

**SOLID CARBIDE SPIRAL CUTTERS FINISH STYLE
Z=3, KleinDIA COATED**

ART. T143.KD

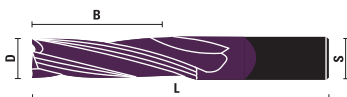

KleinDIA coating for excellent performance

Excellent finish on bottom side



- Right-hand rotation with "UP CUT SPIRAL"
- Polished and coated cutting edge for improved chip evacuation and less friction for excellent performance
- Longer tool life and greater cutting quality
- To be used on machining centres, CNC routers and point to point machines
- For **softwood and hardwood, chipboard, MDF, HF, plywood, plastic coated, mineral materials (CORIAN® ecc.)**

| RH rotation | D | B | L | Z |
|-------------------------|----|----|-----|---|
| T143.081.RKD NEW | 8 | 35 | 80 | 3 |
| T143.100.RKD NEW | 10 | 35 | 80 | 3 |
| T143.101.RKD NEW | 10 | 45 | 100 | 3 |
| T143.121.RKD NEW | 12 | 45 | 100 | 3 |

**SOLID CARBIDE SPIRAL CUTTERS ROUGHING STYLE
Z=3, KleinDIA COATED**

ART. T144.KD

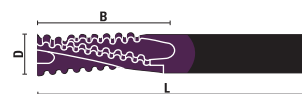

KleinDIA coating for excellent performance

- Right-hand rotation with "UP CUT SPIRAL"
- Polished and coated cutting edge for improved chip evacuation and less friction for excellent performance
- Chip-breaker execution
- Longer tool life and greater cutting quality
- To be used on machining centres, CNC routers and point to point machines
- Suitable for roughing, they guarantee a high feed rate

| RH rotation | D | B | L | Z |
|-------------------------|----|----|-----|---|
| T144.081.RKD NEW | 8 | 35 | 80 | 3 |
| T144.100.RKD NEW | 10 | 35 | 80 | 3 |
| T144.101.RKD NEW | 10 | 45 | 100 | 3 |
| T144.121.RKD NEW | 12 | 45 | 100 | 3 |
| T144.161.RKD NEW | 16 | 55 | 100 | 3 |

**SOLID CARBIDE SPIRAL CUTTERS FPR LOCK-CASE
Z=3, KleinDIA COATED**

ART. T357.KD

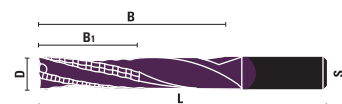

KleinDIA coating for excellent performance

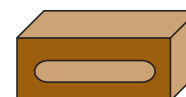

- Right-hand rotation with "UP CUT SPIRAL"
- Semifinished chip-breaker execution (roughing and finishing) as our items T344 - T354 at page 7.60 of our Catalog 14.A
- For locks and slot mortising
- Polished and coated cutting edge for improved chip evacuation and less friction for excellent performance
- To be used on machining centres, CNC routers and point to point machines
- For **softwood and hardwood, chipboard, MDF, HF, plywood, plastic coated, mineral materials (CORIAN® ecc.)**

| RH rotation | D | B1 | B | L | S | Z |
|-------------------------|----|----|-----|-----|-------|---|
| T357.162.RKD NEW | 16 | 45 | 100 | 150 | 16x45 | 3 |

USE EXAMPLE

- Stepwise processing 0,3-0,4 mm
- Can work deeply and have excellent chip evacuation

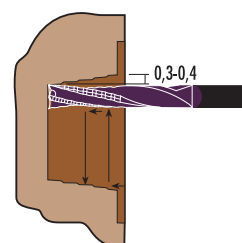

SOLID CARBIDE SPIRAL ROUTER BITS FINISH/ROUGHING STYLE

ART. T344

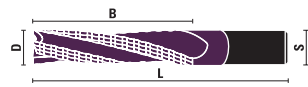

KleinDIA coating for excellent performance

Excellent finish on bottom side



- Right-hand rotation with "UP CUT SPIRAL"
- To be used on machining centres, CNC routers and point to point machines
- Semi-finished chip-breaker execution
- For **softwood and hardwood, chipboard, MDF, HF, plywood, plastic coated, mineral materials (CORIAN® ecc.)**

| RH rotation | D | B | L | Z |
|--------------|----|----|-----|---|
| T344.080.RKD | 8 | 30 | 80 | 2 |
| T344.100.RKD | 10 | 35 | 80 | 2 |
| T344.120.RKD | 12 | 35 | 80 | 3 |
| T344.121.RKD | 12 | 45 | 90 | 3 |
| T344.140.RKD | 14 | 55 | 110 | 3 |
| T344.160.RKD | 16 | 55 | 110 | 3 |
| T344.161.RKD | 16 | 75 | 130 | 3 |
| T344.200.RKD | 20 | 55 | 110 | 3 |
| T344.201.RKD | 20 | 75 | 130 | 3 |

Router bits with diameter from 12 mm, are produced with shank for Seeger retaining rings



HOW TO DETERMINE THE FEEDING SPEED RELATING TO THE DIAMETER:

- Referring to item T344RKD with right hand rotation (UP CUT STYLE), Z=2/3
- Referring to item T354RKD with right hand rotation (DOWN CUT STYLE), Z=2/3
- Referring to item T354LKD with left hand rotation (UP CUT STYLE), Z=2/3
- RPM 18.000

Soft wood

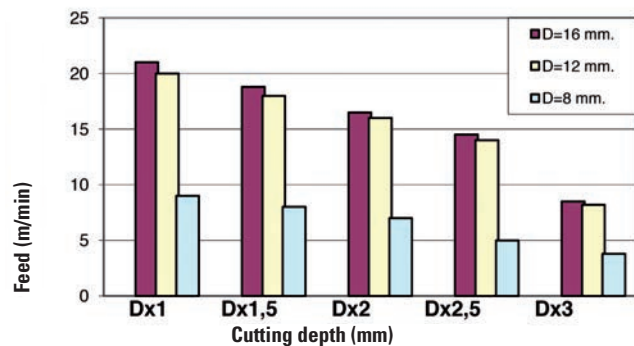

Hard wood

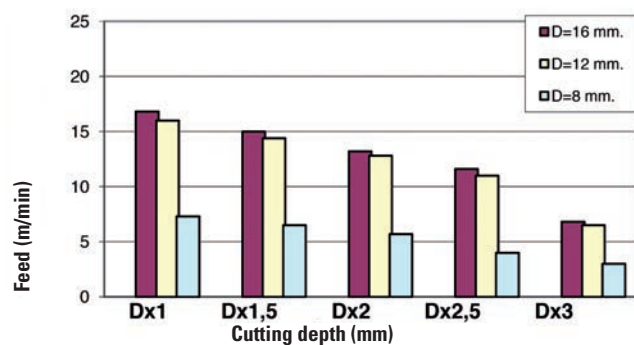

SOLID CARBIDE SPIRAL ROUTER BITS FINISH/ROUGHING STYLE

ART. T354.KD

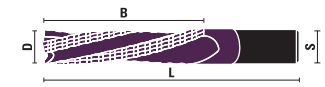

KleinDIA coating for excellent performance

Excellent finish on panel top side



- Right-hand rotation with "DOWN CUT SPIRAL"
- To be used on machining centres, CNC routers and point to point machines
- Semi-finished chip-breaker execution
- For **softwood and hardwood, chipboard, MDF, HF, plywood, plastic coated, mineral materials (CORIAN® ecc.)**

| RH rotation | D | B | L | Z |
|--------------|----|----|-----|---|
| T354.100.RKD | 10 | 35 | 80 | 2 |
| T354.120.RKD | 12 | 35 | 80 | 3 |
| T354.160.RKD | 16 | 55 | 110 | 3 |
| T354.161.RKD | 16 | 75 | 130 | 3 |
| T354.200.RKD | 20 | 55 | 110 | 3 |

Router bits with diameter from 12 mm, are produced with shank for Seeger retaining rings



SOLID CARBIDE SPIRAL ROUTER BITS FINISH/ROUGHING STYLE

ART. T354.KD

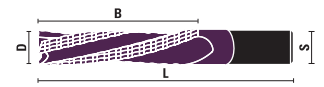

KleinDIA coating for excellent performance

Excellent finish on bottom side



- Left-hand rotation with "UP CUT SPIRAL"
- To be used on machining centres, CNC routers and point to point machines
- Semi-finished chip-breaker execution
- For **softwood and hardwood, chipboard, MDF, HF, plywood, plastic coated, mineral materials (CORIAN® ecc.)**

| LH rotation | D | B | L | Z |
|--------------|----|----|-----|---|
| T354.100.LKD | 10 | 35 | 80 | 2 |
| T354.120.LKD | 12 | 35 | 80 | 3 |
| T354.160.LKD | 16 | 55 | 110 | 3 |
| T354.161.LKD | 16 | 75 | 130 | 3 |
| T354.200.LKD | 20 | 55 | 110 | 3 |

Router bits with diameter from 12 mm, are produced with shank for Seeger retaining rings



TOOL KIT FOR CNC ROUTERS

ART. X118

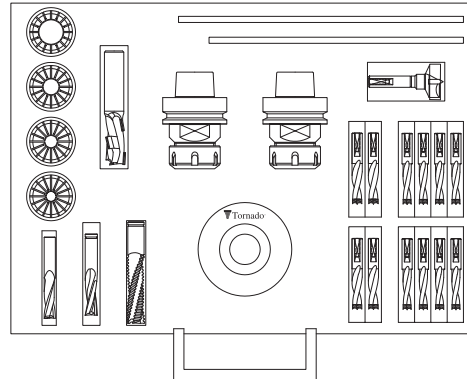

HSK63F for ER 32 spring collets

Item
X118.001.N **NEW**

Complete with:

T118.976.R - nr. 2
Collet chucks HSK63F for ER 32

T119.080.R - nr. 1 - D=8
T119.120.R - nr. 1 - D=12
T119.160.R - nr. 1 - D=16
T119.200.R - nr. 1 - D=20
Spring collet - ER 32 - DIN 6499

T144.161.R - nr. 1 - D=16
Solid carbide spiral cutters, roughing style Z=3

T142.081.R - nr. 1 - D=8
T142.120.R - nr. 1 - D=12
Solid carbide spiral cutters, finish style Z=2

X502.203.R - nr. 1 - D=20
DP router bits

Z052.401.N - nr. 1
Wrenches for collet nut "standard" ER 32

Z052.315.N - nr. 1
Hook wrench 95/100 for art. T139.501.RK Tornado®

L115.050.R - nr. 4 - D=5x70
L115.050.L - nr. 4 - D=5x70
L115.080.R - nr. 2 - D=8x70
L115.080.L - nr. 2 - D=8x70
HW dowel drills extra time Z=2

L141.350.R - nr. 1 - D=35
HW hinge boring bits Z=2+2

T139.501.RK - nr. 1
Dust & chip extraction nut type ER 32 - DIN6499 Tornado®

HSK63F for ER 40 spring collets

Item
X118.002.N **NEW**

Complete with:

T118.980.R - nr. 2
Collet chucks HSK63F for ER 40

T123.080.R - nr. 1 - D=8
T123.120.R - nr. 1 - D=12
T123.160.R - nr. 1 - D=16
T123.200.R - nr. 1 - D=20
Spring collet ER 40 - DIN 6499

T144.161.R - nr. 1 - D=16
Solid carbide spiral cutters, roughing style Z=3

T142.081.R - nr. 1 - D=8
T142.120.R - nr. 1 - D=12
Solid carbide spiral cutters, finish style Z=2

X502.203.R - nr. 1 - D=20
DP router bits

Z052.402.N - nr. 1
Wrenches for collet nut "standard" ER 40

Z052.315.N - nr. 1
Hook wrench 95/100 for art. T139.502.RK Tornado®

L115.050.R - nr. 4 - D=5x70
L115.050.L - nr. 4 - D=5x70
L115.080.R - nr. 2 - D=8x70
L115.080.L - nr. 2 - D=8x70
HW dowel drills extra time Z=2

L141.350.R - nr. 1 - D=35
HW hinge boring bits Z=2+2

T139.502.RK - nr. 1
Dust & chip extraction nut type ER 40 - DIN6499 Tornado®

HSK63F for EOC25 spring collets

Item
X118.003.N **NEW**

Complete with:

T118.984.R - nr. 2
Collet chucks HSK63F for EOC25 with ball bearing

T124.080.R - nr. 1 - D=8
T124.120.R - nr. 1 - D=12
T124.160.R - nr. 1 - D=16
T124.200.R - nr. 1 - D=20
Spring collet EOC25 - DIN 6388

T144.161.R - nr. 1 - D=16
Solid carbide spiral cutters, roughing style Z=3

T142.081.R - nr. 1 - D=8
T142.120.R - nr. 1 - D=12
Solid carbide spiral cutters, finish style Z=2

X502.203.R - nr. 1 - D=20
DP router bits

Z052.310.N - nr. 1 (58/62)
Wrenches for collet nut EOC25/DIN6388

Z052.315.N - nr. 1
Hook wrench 95/100 for art. T139.522.RK Tornado®

L115.050.R - nr. 4 - D=5x70
L115.050.L - nr. 4 - D=5x70
L115.080.R - nr. 2 - D=8x70
L115.080.L - nr. 2 - D=8x70
HW dowel drills extra time Z=2

L141.350.R - nr. 1 - D=35
HW hinge boring bits Z=2+2

T139.522.RK - nr. 1
Dust & chip extraction nut type EOC25- DIN6388 Tornado®

TOOL KIT FOR CNC ROUTERS

ART. X118

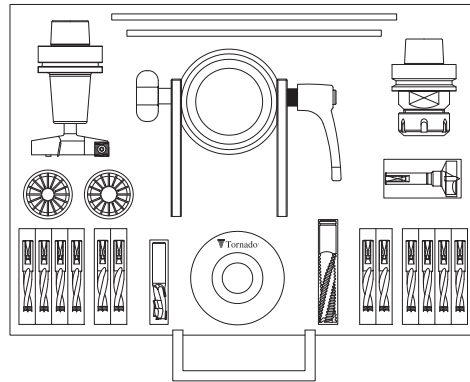

HSK63F for ER 32 spring collets

Item

X118.011.N **NEW**

Complete with:

T118.976.R - nr. 1

Collet chucks HSK63F for ER 32

T119.120.R - nr. 1 - D=12

T119.160.R - nr. 1 - D=16

Spring collet ER 32 - DIN 6499

T144.161.R - nr. 1 - D=16

Solid carbide spiral cutters, roughing style Z=3

X500.120.R - nr. 1 - D=12

DP router bits

WE190.800.R - nr. 1 - D=80

Frese con coltellini HW per spianare Z=3

T120.620.R - nr. 1 - D=12

Shrink fit chucks HSK63F

Z052.401.N - nr. 1

Chiavi per ghiera tipo standard ER 32

Z052.315.N - nr. 1

Chiavi a settore 95/100 per art. T139.501.RK Tornado®

L115.050.R - nr. 4 - D=5x70

L115.050.L - nr. 4 - D=5x70

L115.080.R - nr. 2 - D=8x70

L115.080.L - nr. 2 - D=8x70

HW dowel drills extra time Z=2

L141.350.R - nr. 1 - D=35

HW hinge boring bits Z=2+2

T139.163.N - nr. 1

Adjustable demount devices

T139.501.RK - nr. 1

Dust & chip extraction nut type ER 32 - DIN6499 Tornado®

HSK63F for ER 40 spring collets

Item

X118.012.N **NEW**

Complete with:

T118.980.R - nr. 1

Collet chucks HSK63F for ER 40

T123.120.R - nr. 1 - D=12

T123.160.R - nr. 1 - D=16

Spring collet ER 40 - DIN 6499

T144.161.R - nr. 1 - D=16

Solid carbide spiral cutters, roughing style Z=3

X500.120.R - nr. 1 - D=12

DP router bits

WE190.800.R - nr. 1 - D=80

Frese con coltellini HW per spianare Z=3

T120.620.R - nr. 1 - D=12

Shrink fit chucks HSK63F

Z052.402.N - nr. 1

Chiavi per ghiera tipo standard ER 40

Z052.315.N - nr. 1

Chiavi a settore 95/100 per art. T139.502.RK Tornado®

L115.050.R - nr. 4 - D=5x70

L115.050.L - nr. 4 - D=5x70

L115.080.R - nr. 2 - D=8x70

L115.080.L - nr. 2 - D=8x70

HW dowel drills extra time Z=2

L141.350.R - nr. 1 - D=35

HW hinge boring bits Z=2+2

T139.163.N - nr. 1

Adjustable demount devices

T139.502.RK - nr. 1

Dust & chip extraction nut type ER 40 - DIN6499 Tornado®

HSK63F for EOC25 spring collets

Item

X118.013.N **NEW**

Complete with:

T118.984.R - nr. 1

Collet chucks HSK63F for EOC25 with ball bearing

T124.120.R - nr. 1 - D=12

T124.160.R - nr. 1 - D=16

Spring collet EOC25 - DIN 6388

T144.161.R - nr. 1 - D=16

Solid carbide spiral cutters, roughing style Z=3

X500.120.R - nr. 1 - D=12

DP router bits

WE190.800.R - nr. 1 - D=80

Frese con coltellini HW per spianare Z=3

T120.620.R - nr. 1 - D=12

Shrink fit chucks HSK63F

Z052.310.N - nr. 1 (58/62)

Chiavi a settore per ghiera EOC25/DIN6388

Z052.315.N - nr. 1

Chiavi a settore 95/100 per art. T139.522.RK Tornado®

L115.050.R - nr. 4 - D=5x70

L115.050.L - nr. 4 - D=5x70

L115.080.R - nr. 2 - D=8x70

L115.080.L - nr. 2 - D=8x70

HW dowel drills extra time Z=2

L141.350.R - nr. 1 - D=35

HW hinge boring bits Z=2+2

T139.163.N - nr. 1

Adjustable demount devices

T139.522.RK - nr. 1

Dust & chip extraction nut type EOC25 - DIN6388 Tornado®

MODULAR DRAWER UNIT

Drawer unit

"Elegant, sturdy **Klein** drawer unit with an innovative, modern design and great modularity, where you can keep all your **Klein** tools in a clean, secure, well-organized place. Say good-bye to messiness and damaged tools. Now, with the new **Klein** drawer unit, you can put your storeroom in order in a convenient, functional way.

SMALL OUTSIDE BUT LARGE INSIDE
the **Klein** drawer unit takes up little space but can contain countless articles in its 10 drawers and 80 containers (8 containers per drawer).

- **STURDY**
since each drawer can hold around 8 kg.
- **LIGHT**
since it's made of a high-strength polypropylene co-polymer.
- **SECURE**
since each drawer has its own key.
- **PRACTICAL**
since it can be equipped with 4 casters for convenient movement or with slip-resistant feet.
- **CONVENIENT**
since it features a wooden top which acts as a practical surface for taking notes or keeping tools.
- **VERSATILE**
since the tubs in the drawers can be removed easily as desired.

Whether it's placed next to a CNC router, or close to a point-to-point boring machine, along the panel production line or in any carpentry shop, the new **Klein** drawer unit can be a real help in keeping the tools you use every day in perfect order and in good condition.



The new **Klein** drawer unit can hold a wide range of tools.
Ask our customer service how to receive it.

Modular drawer unit "CNC"

Ideal to store collet chucks, spring collets and spiral router bits beside your CNC machine



1st Drawer

Spring collets ER32

- Art. T119.060.N
- T119.080.N
- T119.100.N
- T119.120.N
- T119.140.N
- T119.160.N
- T119.180.N
- T119.200.N

2nd Drawer

Spring collets ER40

- Art. T123.080.N
- T123.100.N
- T123.120.N
- T123.140.N
- T123.160.N
- T123.180.N
- T123.200.N
- T123.250.N

3rd Drawer

Collet chucks and spring collets ER25

- Art. T118.700.R
- T118.800.R
- T118.976.R
- T118.980.R
- T125.060.N
- T125.080.N
- T125.100.N
- T125.120.N

4th Drawer

Spiral router bits Z=2

- Art. T142.040.R
- T142.050.R
- T142.061.R
- T142.080.R
- T142.081.R
- T142.100.R
- T142.101.R
- T142.121.R

5th Drawer

Spiral router bits Z=3

- Art. T143.081.R
- T143.100.R
- T143.101.R
- T143.121.R
- T143.161.R
- T143.180.R
- T143.200.R
- T143.201.R

6th Drawer

Spiral router bits Z=3 + chipbreaker

- Art. T144.081.R
- T144.100.R
- T144.101.R
- T144.121.R
- T144.161.R
- T144.180.R
- T144.200.R
- T144.201.R

7th Drawer

Spiral router bits Z=1

- Art. T141.030.R
- T141.040.R
- T141.050.R
- T141.061.R
- T141.081.R
- T141.100.R
- T151.061.R
- T151.081.R

8th Drawer

Spiral router bits Z=2 down-cut

- Art. T152.030.R
- T152.040.R
- T152.050.R
- T152.061.R
- T152.080.R
- T152.081.R
- T152.101.R
- T152.121.R

9th Drawer

Spiral router bits for locks

- Art. T153.100.R
- T153.120.R
- T153.160.R
- T154.081.R
- T154.120.R
- T154.160.R
- T157.140.R
- T157.162.R

10th Drawer

Straight cut router bits

- Art. D101.080.R
- D101.100.R
- D102.100.R
- D103.121.R
- D103.141.R
- D103.161.R
- D103.181.R
- D103.201.R

Router bits for aluminium and plastic working



8



**SOLID CARBIDE SPIRAL BITS
DOWN CUT Z=1**
Page 8.04



**SOLID CARBIDE SPIRAL BITS
UP CUT Z=1**
Page 8.04



**SOLID CARBIDE SPIRAL CUTTERS Z=5
SUPER-FINISHING**
Pag. 8.04



**SOLID CARBIDE SPIRAL BITS
UP CUT Z=1 - Z=2**
Page 8.04



**SOLID CARBIDE SPIRAL BITS
DOWN CUT Z=2**
Page 8.04



**SOLID CARBIDE SPIRAL BITS DOWN
CUT Z=1 KLEINDIA COATED**
Page 8.06



**SOLID CARBIDE SPIRAL BITS
UP CUT Z=1 KLEINDIA COATED**
Page 8.06



**SOLID CARBIDE SPIRAL BITS
UP CUT Z=1 - Z=2 KLEINDIA COATED**
Page 8.06



**SOLID CARBIDE SPIRAL BITS
DOWN CUT Z=2 KLEINDIA COATED**
Page 8.06

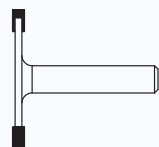

T-SLOT HW CUTTER Z=4
Page 8.07

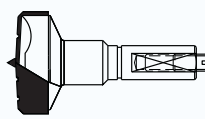

**HW HINGE BORING BITS FOR
ALUMINIUM Z=2**
Page 8.07



**SOLID CARBIDE SPIRAL BITS
DOWN CUT Z=2**
Page 8.07



**SOLID CARBIDE SPIRAL BITS
DOWN CUT Z=4**
Page 8.07

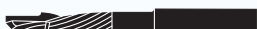

**SOLID CARBIDE DOUBLE DIAMETER
SPIRAL BITS Z=1**
Page 8.07



**SOLID CARBIDE SPIRAL CUTTERS Z=5
SUPER-FINISHING KLEINDIA COATED**
Pag. 8.08



**SOLID CARBIDE BITS FOR FIBERGLASS
WORKING, KLEINDIA COATED**
Page 8.08



**SOLID CARBIDE SPIRAL CUTTERS Z=2,
KLEINDIA COATED**
Pag. 8.08

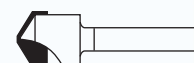

**HW DRILLS FOR WORKING
ALUCOBOND® Z=2**
Pag. 8.08

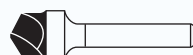

**SOLID CARBIDE BITS FOR WORKING
ALUCOBOND® Z=2**
Pag. 8.08

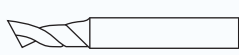

**HS UPCUT SPIRAL BITS FOR
ALUMINIUM Z=1**
Page 8.09

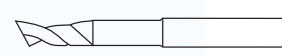

**HS UPCUT SPIRAL BITS FOR
ALUMINIUM Z=1**
Page 8.09

Klein®





SET FOR ALU
Page 8.09

KleinDIA



HS UPcut SPIRAL BITS FOR ALUMINIUM
Z=1 KLEINDIA COATED
Pag. 8.10

KleinDIA



HS UPcut SPIRAL BITS FOR
ALUMINIUM Z=1 LONG TYPE,
KLEINDIA COATED
Pag. 8.10



HS DOUBLE DIAMETER SPIRAL BITS
FOR ALUMINIUM Z=2
Page 8.10



HS SPECIAL BITS FOR PVC Z=1
Page 8.10



HS SPECIAL BITS FOR PVC Z=2
Page 8.10



HS UPcut SPIRAL CUTTERS FOR
ALUMINIUM Z=2-Z=3
Page 8.11



HS DRILLING BITS FOR PVC AND
ALUMINIUM WORKING Z=2
Page 8.11



HS DRILLING BITS FOR PVC AND
ALUMINIUM WORKING Z=2
Page 8.11



HS DOUBLE DIAMETER SPIRAL BITS
FOR ALUMINIUM Z=2
Page 8.11

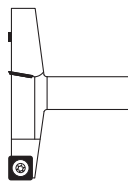

HW INSERT ROUTER BITS
FOR PLASTIC MATERIAL
Page 8.11



HOLDING SLEEVES FOR MILLING
CUTTER SETS WITH
MANUAL INSERTION
Page 8.12

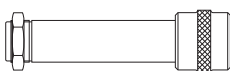

QUICK CHANGE HOLDING SLEEVES
FOR MILLING CUTTER SETS
Page 8.12

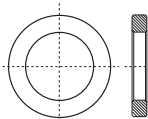

SPACERS
Page 8.12



HW ALTERNATE TOOTH MILLING CUTTERS
Page 8.12

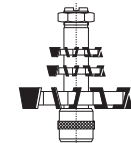

SPECIAL UNITS FOR
ALUMINIUM-PROFILES
Page 8.13



HW TRIMMING AND SIZING SAWBLADES
Page 8.13



HW TRIMMING AND SIZING SAWBLADES
Page 8.13



HW SAWBLADES FOR PVC AND PLEXIGLASS
Page 8.13



HW SAWBLADES
FOR ALUMINIUM
Page 8.14



HW SAWBLADES FOR PVC
Page 8.15

CLASSIFICATION OF PLASTIC MATERIALS

“Plastic” is a generic term used to indicate a type of material that can actually be constituted by an innumerable variety of combinations of polymer structures and sizes.

For this reason it is very hard to define precisely the working parameters (feed rates and RPM) of plastic materials.

Here some guidelines that can help:

working with a CNC machine;

- use router bits Z=1 which allow a better chip flow, when working soft or flexible material;
- increase the chip load to avoid tool wear;

working with a table saw;

- use a sawblade with higher number of teeth when working hard materials.

Plastic working with a CNC machine, RPM =18.000, solid carbide router bit Z=1

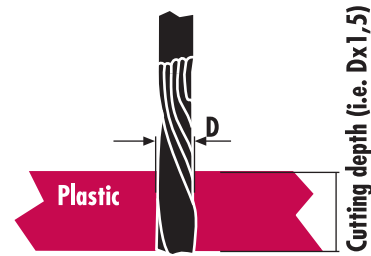
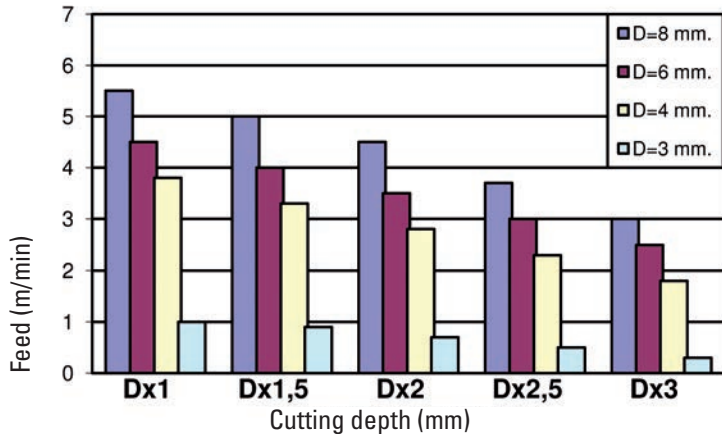

The harder is the material, the higher is the tensile strength (MPa). Harder material is less elastic (%). In this case it is recommended to use tools with higher number of teeth.

Reference table to identify the type of plastic processed and the right tool to use

| Symbol | Abbreviation | Name | Tensile strength (MPa) | Elongation at ruptore (%) | Some examples of use |
|-------------|---------------------------|--------------------------------------|------------------------|---------------------------|--|
| 01 PET | PETE PET | Polyethylene Terephthalate or arnite | 2300-10300 | 7 | Plastic bottles, belts, pipes, etc. |
| 01 PET | POLYESTER | Polyethylene Terephthalate or arnite | 2400 | 300 | Home design (flooring and furniture coating), clothing, etc. |
| 02 PE-HD | HDPE | High density Polyethylene | 700-1400 | 15-100 | Bottles, packaging, wood plastic composites, etc. |
| 03 PVC | PVC V | Polyvinyl chloride | 200-4200 | 2-30 | Pipes, fencing, containers, etc. |
| 04 PE-LD | LDPE | Low density Polyethylene | 100-250 | 50-800 | General purpose containers, aseptic packaging, etc. |
| 05 PP | PP | Polyethylene or Moplen | 1350 | 150-600 | Automotive industry and fibre production |
| 06 PS | PS | Polystyrene | 2400-3350 | 1-4 | Toys, office supplies, trays, videotapes, thermal insulation foam (Styrofoam™), etc. |
| 07 O | METHYL METHACRYLATE RESIN | Synthetic polyamides | 1500-3000 | 30-150 | Furniture, flooring, clothing, etc. |
| 07 O | FIBERGLASS | Synthetic polyamides | 4500 | 40 | Shipbuilding, aerospace and automotive industry, etc. |

SOLID CARBIDE SPIRAL BITS DOWN CUT Z=1

ART. U101

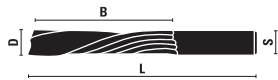

- Right-hand rotation with "DOWN CUT SPIRAL"
- Polished cutting edge for improved chip evacuation
- Use on CNC and high speed machines
- For working plastic materials (thin prefinished panels, 3/4 mm.), PVC, HDPE, PET, acrylic materials and solid surface

| RH rotation | D | B | L | S |
|-------------|----|----|----|----|
| U101.030.R | 3 | 15 | 50 | 3 |
| U101.040.R | 4 | 35 | 70 | 4 |
| U101.041.R | 4 | 20 | 60 | 4 |
| U101.050.R | 5 | 35 | 70 | 5 |
| U101.051.R | 5 | 25 | 60 | 5 |
| U101.060.R | 6 | 35 | 80 | 6 |
| U101.061.R | 6 | 25 | 70 | 6 |
| U101.080.R | 8 | 35 | 80 | 8 |
| U101.081.R | 8 | 25 | 70 | 8 |
| U101.100.R | 10 | 35 | 80 | 10 |
| U101.101.R | 10 | 25 | 70 | 10 |
| U101.120.R | 12 | 35 | 80 | 12 |

SOLID CARBIDE SPIRAL BITS UP CUT Z=1

ART. U102



- Right-hand rotation with "UP CUT SPIRAL"
- Polished cutting edge for improved chip evacuation
- Use on CNC and high speed machines
- For working plastic materials, fiberglass, phenols materials and solid surface

| RH rotation | D | B | L | S |
|-------------|----|----|----|----|
| U102.040.R | 4 | 35 | 70 | 4 |
| U102.050.R | 5 | 35 | 70 | 5 |
| U102.060.R | 6 | 35 | 80 | 6 |
| U102.080.R | 8 | 35 | 80 | 8 |
| U102.100.R | 10 | 35 | 80 | 10 |

SOLID CARBIDE SPIRAL CUTTERS Z=5 SUPER-FINISHING

ART. U115

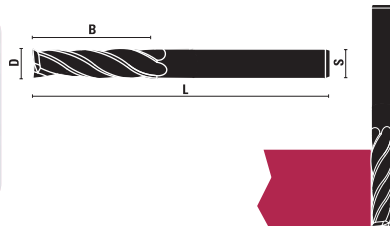

- Right-hand rotation with "UP CUT SPIRAL"
- For working plexiglass and acrylic
- Polished cutting edge for improved chip evacuation and less friction
- To be used on machining centres and CNC routers
- Especially made for plexiglass polishing and best finishing cuts

| RH rotation | D | B | L | S |
|----------------|----|----|----|----|
| U115.060.R NEW | 6 | 25 | 70 | 6 |
| U115.080.R NEW | 8 | 30 | 80 | 8 |
| U115.100.R NEW | 10 | 35 | 80 | 10 |

SOLID CARBIDE SPIRAL BITS UP CUT Z=1 - Z=2

ART. U111 - U112

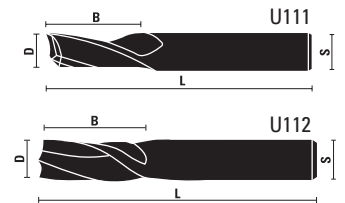

- Right-hand rotation with "UP CUT SPIRAL"
- Polished cutting edge for improved chip evacuation. Mirror finish
- Spiral 'O' flute sharpening
- Use on CNC and high speed machines
- For working: • aluminium • fiberglass • plastic • phenolic • acrylic • PVC

| RH rotation | D | B | L | S | Z |
|----------------|-------|--------|--------|------|---|
| U111.030.R | 3 | 12 | 60 | 6 | 1 |
| U111.032.R NEW | 1/8" | 1/2" | 2" | 1/4" | 1 |
| U111.040.R | 4 | 12 | 60 | 6 | 1 |
| U111.048.R NEW | 3/16" | 5/8" | 2" | 1/4" | 1 |
| U111.050.R | 5 | 16 | 60 | 6 | 1 |
| U111.060.R | 6 | 16 | 60 | 6 | 1 |
| U111.061.R | 6 | 35 | 80 | 6 | 1 |
| U111.064.R NEW | 1/4" | 3/4" | 2" | 1/4" | 1 |
| U111.080.R | 8 | 18 | 60 | 8 | 1 |
| U111.081.R | 8 | 35 | 80 | 8 | 1 |
| U111.095.R NEW | 3/8" | 3/4" | 3" | 3/8" | 1 |
| U111.100.R | 10 | 22 | 70 | 10 | 1 |
| U111.120.R | 12 | 24 | 70 | 12 | 1 |
| U111.127.R NEW | 1/2" | 1-1/4" | 3" | 1/2" | 1 |
| U112.040.R | 4 | 10 | 60 | 6 | 2 |
| U112.048.R NEW | 3/16" | 1/2" | 2" | 1/4" | 2 |
| U112.050.R | 5 | 12 | 60 | 6 | 2 |
| U112.060.R | 6 | 15 | 60 | 6 | 2 |
| U112.064.R NEW | 1/4" | 3/4" | 2" | 1/4" | 2 |
| U112.080.R | 8 | 20 | 60 | 8 | 2 |
| U112.095.R NEW | 3/8" | 1" | 3" | 3/8" | 2 |
| U112.100.R | 10 | 22 | 70 | 10 | 2 |
| U112.120.R | 12 | 25 | 80 | 12 | 2 |
| U112.127.R NEW | 1/2" | 1-1/2" | 3-1/2" | 1/2" | 2 |
| U112.140.R | 14 | 25 | 80 | 14 | 2 |
| U112.160.R | 16 | 25 | 80 | 16 | 2 |

SOLID CARBIDE SPIRAL BITS UP CUT Z=2

ART. U120

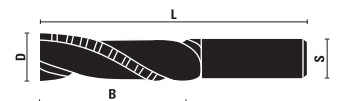

- Right-hand rotation with "UP CUT SPIRAL"
- With chip-breaker
- Discontinuous cutting edge
- For working wood and aluminium material
- Use on CNC and high speed machines

| RH rotation | D | B | L | S |
|-------------|----|----|-----|----|
| U120.140.R | 14 | 42 | 100 | 14 |
| U120.160.R | 16 | 42 | 100 | 16 |
| U120.180.R | 18 | 62 | 120 | 18 |
| U120.200.R | 20 | 62 | 120 | 20 |

Router bits with diameter from 14 mm to 20 mm, are produced with shank fit for Seeger retaining rings



KleinDIA®

A surface treatment developed for large-scale production

KleinDIA is a DLC (**Diamond-like Carbon**) anti-friction coating which allows to solve problems of tool abrasion, chip evacuation and chemical attack.

A layer of apprx. 1 micron is laid on the tool surface at low temperature, thus not altering the properties of the router bit or knife. Its high hardness is granted by both Sp2 (**Graphite**) and Sp3 (**Diamond**) carbon hybridisation.

Our several tests confirmed remarkable results on both panel working and solid wood processing.

Working plastic and aluminium without coolant is also possible thanks to a very low friction coefficient.

TECHNICAL FEATURES:

- **High hardness** Hv0,025: 2500-3100
- **Higher wear resistance** (longer working time)
- **Low frictional coefficient** (lowered working temperature)
- **Very low sticking coefficient** (Better chips evacuation)
- **Thickness:** apprx. 1 micron
- **Colour:** bright black



KleinDIA is the most advantageous coating, ensuring:

- **Production increase**
- **Better finishing**
- **Less maintenance**

The surface coating **KleinDIA** can be applied on many other products giving extraordinary results depending on the type of material processed. Excellent results can be achieved processing solid wood, plywood, Plexiglas, plastic and graphitic materials.

HERE ARE SOME OF THE ITEMS WHICH ARE SUITABLE TO BE COATED WITH KleinDIA:

Solid carbide straight router bits
ART. A101/2/3 - C101/2/3 - C190 - D101/2



Page 1.07, 1.23, 2.05

Solid carbide spiral router bits
ART. T141/2/3 - T151/2/3 - T157/8/9



Page from 7.46 to 7.52, 7.54

Solid carbide dowel drills
ART. L116 - L117



Pag. 5.11

Solid carbide through-hole boring bits
ART. L134 - L135



Pag. 5.17

HW reversible knives
ART. ZB



Pag. 11.10

HS planer knives
ART. ZC 30 - ZC 35



Pag. 11.11, 11.12, 11.13



SOLID CARBIDE SPIRAL BITS DOWN CUT Z=1

KleinDIA COATED

ART. U101.KD

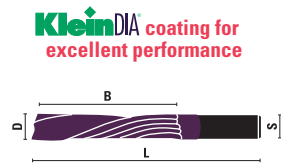

- Right-hand rotation with "DOWN CUT SPIRAL"
- Polished and coated cutting edge for improved chip evacuation and less friction for excellent performance
- Use on CNC and high speed machines
- For working plastic materials (thin prefinished panels, 3/4 mm.), PVC, HDPE, PET, acrylic materials and solid surface

| RH rotation | D | B | L | S |
|--------------|----|----|----|----|
| U101.030.RKD | 3 | 15 | 50 | 3 |
| U101.040.RKD | 4 | 35 | 70 | 4 |
| U101.041.RKD | 4 | 20 | 60 | 4 |
| U101.050.RKD | 5 | 35 | 70 | 5 |
| U101.051.RKD | 5 | 25 | 60 | 5 |
| U101.060.RKD | 6 | 35 | 80 | 6 |
| U101.061.RKD | 6 | 25 | 70 | 6 |
| U101.080.RKD | 8 | 35 | 80 | 8 |
| U101.081.RKD | 8 | 25 | 70 | 8 |
| U101.100.RKD | 10 | 35 | 80 | 10 |
| U101.101.RKD | 10 | 25 | 70 | 10 |
| U101.120.RKD | 12 | 35 | 80 | 12 |

SOLID CARBIDE SPIRAL BITS UP CUT Z=1

KleinDIA COATED

ART. U102.KD

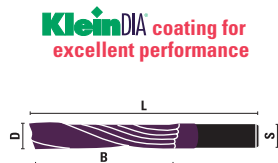

- Right-hand rotation with "UP CUT SPIRAL"
- Polished and coated cutting edge for improved chip evacuation and less friction for excellent performance
- Use on CNC and high speed machines
- For working plastic materials, fiberglass, phenols materials and solid surface

| RH rotation | D | B | L | S |
|--------------|----|----|----|----|
| U102.040.RKD | 4 | 35 | 70 | 4 |
| U102.050.RKD | 5 | 35 | 70 | 5 |
| U102.060.RKD | 6 | 35 | 80 | 6 |
| U102.080.RKD | 8 | 35 | 80 | 8 |
| U102.100.RKD | 10 | 35 | 80 | 10 |

SOLID CARBIDE SPIRAL BITS UP CUT Z=1-Z=2

KleinDIA COATED

ART. U111.KD - U112.KD

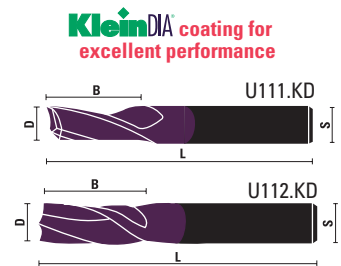

- Right-hand rotation with "UP CUT SPIRAL"
- Polished and coated cutting edge for improved chip evacuation. Mirror finish
- Spiral '0' flute sharpening
- Use on CNC and high speed machines
- For working: • aluminium • fiberglass • plastic • phenolic • acrylic • PVC

| RH rotation | D | B | L | S | Z |
|-------------------------|-------|--------|--------|------|---|
| U111.030.RKD | 3 | 12 | 60 | 6 | 1 |
| U111.032.RKD NEW | 1/8" | 1/2" | 2" | 1/4" | 1 |
| U111.040.RKD | 4 | 12 | 60 | 6 | 1 |
| U111.048.RKD NEW | 3/16" | 5/8" | 2" | 1/4" | 1 |
| U111.050.RKD | 5 | 16 | 60 | 6 | 1 |
| U111.060.RKD | 6 | 16 | 60 | 6 | 1 |
| U111.061.RKD | 6 | 35 | 80 | 6 | 1 |
| U111.064.RKD NEW | 1/4" | 3/4" | 2" | 1/4" | 1 |
| U111.080.RKD | 8 | 18 | 60 | 8 | 1 |
| U111.081.RKD | 8 | 35 | 80 | 8 | 1 |
| U111.095.RKD NEW | 3/8" | 3/4" | 3" | 3/8" | 1 |
| U111.100.RKD | 10 | 22 | 70 | 10 | 1 |
| U111.120.RKD | 12 | 24 | 70 | 12 | 1 |
| U111.127.RKD NEW | 1/2" | 1-1/4" | 3" | 1/2" | 1 |
| U112.040.RKD | 4 | 10 | 60 | 6 | 2 |
| U112.048.RKD NEW | 3/16" | 1/2" | 2" | 1/4" | 2 |
| U112.050.RKD | 5 | 12 | 60 | 6 | 2 |
| U112.060.RKD | 6 | 15 | 60 | 6 | 2 |
| U112.064.RKD NEW | 1/4" | 3/4" | 2" | 1/4" | 2 |
| U112.080.RKD | 8 | 20 | 60 | 8 | 2 |
| U112.095.RKD NEW | 3/8" | 1" | 3" | 3/8" | 2 |
| U112.100.RKD | 10 | 22 | 70 | 10 | 2 |
| U112.120.RKD | 12 | 25 | 80 | 12 | 2 |
| U112.127.RKD NEW | 1/2" | 1-1/2" | 3-1/2" | 1/2" | 2 |
| U112.140.RKD | 14 | 25 | 80 | 14 | 2 |
| U112.160.RKD | 16 | 25 | 80 | 16 | 2 |

Router bits with diameter from 12 mm to 16 mm, are produced with shank fit for Seeger retaining rings



SOLID CARBIDE SPIRAL BITS UP CUT Z=2

KleinDIA COATED

ART. U120.KD

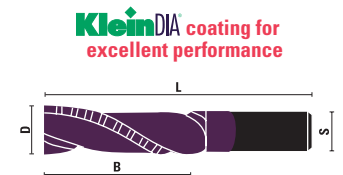

- Right-hand rotation with "UP CUT SPIRAL"
- Polished and coated cutting edge for improved chip evacuation and less friction for excellent performance
- Discontinuous cutting edge
- For working wood and aluminium material
- With chip-breaker
- Use on CNC and high speed machines

| RH rotation | D | B | L | S |
|--------------|----|----|-----|----|
| U120.140.RKD | 14 | 42 | 100 | 14 |
| U120.160.RKD | 16 | 42 | 100 | 16 |
| U120.180.RKD | 18 | 62 | 120 | 18 |
| U120.200.RKD | 20 | 62 | 120 | 20 |

T-SLOT HW CUTTERS Z=4

ART. C173

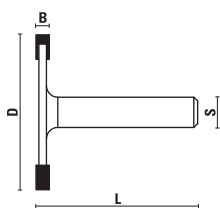

Four wings slot cutters for working plastic material

| S Ø 8 | D | B | L |
|-----------------------|----|-----|----|
| C173.020.R NEW | 41 | 2 | 43 |
| C173.025.R NEW | 41 | 2,5 | 43 |
| C173.030.R NEW | 41 | 3 | 44 |
| C173.035.R NEW | 41 | 3,5 | 44 |
| C173.040.R NEW | 41 | 4 | 45 |
| C173.045.R NEW | 41 | 4,5 | 45 |
| C173.050.R NEW | 41 | 5 | 46 |

HW HINGE BORING BITS FOR ALUMINIUM Z=2

ART. U140

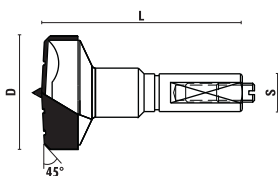

- **Chip-breaker** execution Z=2
- For working aluminium

| RH rotation | D | L | S | Rot. |
|-------------|----|------|-------|------|
| U140.250.R | 25 | 57,5 | 10x26 | RH |
| U140.350.R | 35 | 57,5 | 10x26 | RH |



Z051.302.R



Z059.001.L



Z059.001.R

SOLID CARBIDE SPIRAL BITS DOWN CUT Z=2

ART. U150

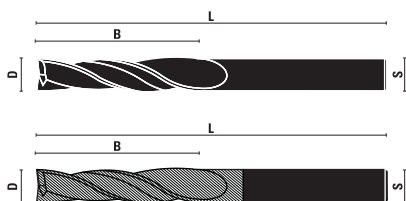

- "RT" with special coating **TICN** for working inox and ferrous materials
- Use on CNC machines
- For working **aluminum** and **ferrous materials**

| RH rotation | D | B | L | S |
|-------------|----|----|-----|----|
| U150.060.R | 6 | 16 | 60 | 6 |
| U150.080.R | 8 | 45 | 100 | 8 |
| U150.100.R | 10 | 22 | 70 | 10 |
| U150.060.RT | 6 | 16 | 60 | 6 |
| U150.080.RT | 8 | 45 | 100 | 8 |
| U150.100.RT | 10 | 22 | 70 | 10 |

SOLID CARBIDE SPIRAL BITS DOWN CUT Z=4

ART. U155 - U156

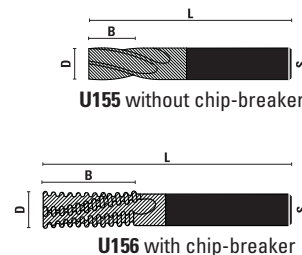

- "RT" with special coating "**TINALOX**"
- Use on CNC machines
- For working **inox** and **ferrous materials**

| RH rotation | D | B | L | S | Z |
|-------------|---|----|----|---|----------------|
| U155.060.RT | 6 | 15 | 60 | 6 | 4 |
| U155.080.RT | 8 | 19 | 65 | 8 | 4 |
| U156.060.RT | 6 | 21 | 60 | 6 | 4 chip-breaker |
| U156.080.RT | 8 | 25 | 70 | 8 | 4 chip-breaker |

SOLID CARBIDE DOUBLE DIAMETER SPIRAL BITS Z=1

ART. U190



- **Right-hand rotation** with "**UP CUT SPIRAL**"
- Use on CNC machines
- For working **aluminum** and **non-ferrous materials**

| RH rotation | d | D | B | I | L | S |
|-------------|-----|------|----|----|-----|----|
| U190.030.R | 3 | 8 | 5 | 30 | 80 | 8 |
| U190.055.R | 5,5 | 8 | 10 | 25 | 100 | 8 |
| U190.060.R | 6 | 11,5 | 10 | 40 | 100 | 12 |

visit our website

www.sistemiklein.com



**SOLID CARBIDE SPIRAL CUTTERS Z=5
SUPER-FINISHING KleinDIA COATED**

ART. U115.KD

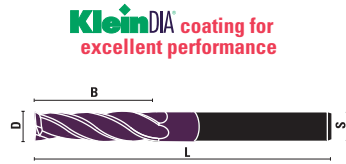

KleinDIA coating for excellent performance

- For working plexiglass and acrylic
- Right-hand rotation with "UP CUT SPIRAL"
- Polished and coated cutting edge for improved chip evacuation and less friction for excellent performance
- To be used on machining centres and CNC routers
- Especially made for plexiglass polishing and best finishing cuts

| RH rotation | D | B | L | S |
|-------------------------|----|----|----|----|
| U115.060.RKD NEW | 6 | 25 | 70 | 6 |
| U115.080.RKD NEW | 8 | 30 | 80 | 8 |
| U115.100.RKD NEW | 10 | 35 | 80 | 10 |

**SOLID CARBIDE BITS FOR FIBERGLASS WORKING
KleinDIA COATED**

ART. U130.KD



KleinDIA coating for excellent performance

- For working plastic materials, rubber and fiberglass
- Right-hand rotation
- For routing and shearing
- To be used on portable machines, CNC and routing machines

| RH rotation | D | B | L | S |
|-------------------------|------|--------|--------|------|
| U130.030.RKD | 3 | 12 | 38 | 3 |
| U130.040.RKD | 4 | 15 | 40 | 4 |
| U130.050.RKD | 5 | 18 | 50 | 5 |
| U130.060.RKD | 6 | 22 | 55 | 6 |
| U130.064.RKD NEW | 1/4" | 1" | 3" | 1/4" |
| U130.080.RKD | 8 | 30 | 70 | 8 |
| U130.095.RKD NEW | 3/8" | 1-1/4" | 3-1/4" | 3/8" |
| U130.100.RKD | 10 | 30 | 72 | 10 |
| U130.120.RKD | 12 | 30 | 73 | 12 |
| U130.127.RKD NEW | 1/2" | 1-1/2" | 3-1/2" | 1/2" |

**SOLID CARBIDE SPIRAL CUTTERS Z=2,
KleinDIA COATED**

ART. U302.KD



KleinDIA coating for excellent performance

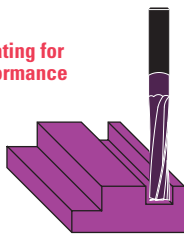

- For working Solid Surface (Corian® - Avonite®)
- Right-hand rotation with "UP CUT SPIRAL"
- Polished cutting edge for improved chip evacuation and less friction by allowing better quality cuts and longer tool life
- Special shear angle for working solid surface without breakage
- Specific solid carbide for best cutting quality

| RH rotation | D | B | L | S |
|-------------------------|----|----|-----|----|
| U302.080.RKD NEW | 8 | 32 | 80 | 8 |
| U302.100.RKD NEW | 10 | 42 | 100 | 10 |
| U302.120.RKD NEW | 12 | 42 | 100 | 12 |
| U302.160.RKD NEW | 16 | 62 | 120 | 16 |

HW DRILLS FOR WORKING ALUCOBOND® Z=2

ART. U180

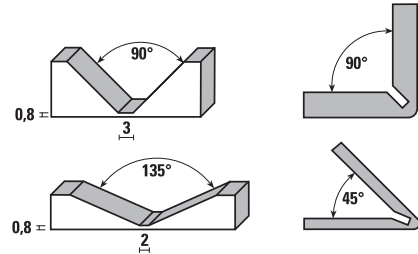
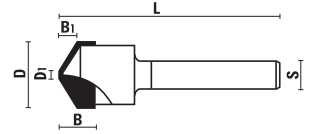

- Carbide tipped cutting edges
- For making V-groove folding on ALUCOBOND®, ALUPANEL®, DIBOND®
- Especially designed for scoring ACM materials with 90° and 135° angles (with flat bottoms), thus allowing a simple hand bending operation of the panel without cracking.
- For portable routers and CNC machining centres

| S Ø 8 | D | D1 | α | B | B1 | L |
|------------|----|----|------|----|-----|----|
| U180.090.R | 18 | 3 | 90° | 10 | 8 | 60 |
| U180.135.R | 18 | 2 | 135° | 10 | 3,3 | 60 |

**SOLID CARBIDE BITS FOR WORKING
ALUCOBOND® Z=2**

ART. U181

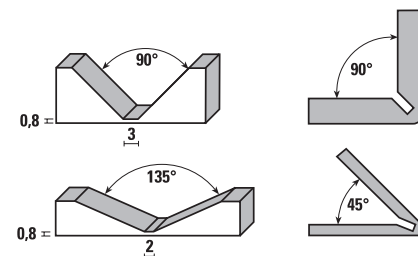
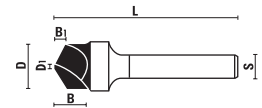

- Solid carbide cutting edges
- For making V-groove folding on ALUCOBOND®, ALUPANEL®, DIBOND®
- Especially designed for scoring ACM materials with 90° and 135° angles (with flat bottoms), thus allowing a simple hand bending operation of the panel without cracking.
- For portable routers and CNC machining centres

| S Ø 8 | D | D1 | α | B | B1 | L |
|-----------------------|----|----|------|----|-----|----|
| U181.090.R NEW | 18 | 3 | 90° | 10 | 8 | 60 |
| U181.135.R NEW | 18 | 2 | 135° | 10 | 3,3 | 60 |

HS UPCUT SPIRAL BITS FOR ALUMINIUM Z=1

ART. U201 - U211 - U221

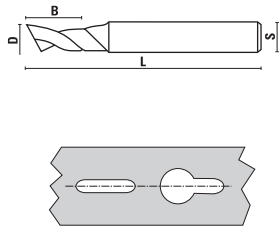

- Manufactured in HS 5% cobalt
- Used for alu profiles
- Plunging and routing
- Use with lubricant

| RH rotation | D | B | L | S | Z |
|-------------|----|----|-----|----|---|
| U201.030.R | 3 | 12 | 60 | 8 | 1 |
| U201.040.R | 4 | 12 | 60 | 8 | 1 |
| U201.041.R | 4 | 40 | 100 | 8 | 1 |
| U201.042.R | 4 | 12 | 100 | 8 | 1 |
| U201.050.R | 5 | 14 | 70 | 8 | 1 |
| U201.051.R | 5 | 40 | 100 | 8 | 1 |
| U201.052.R | 5 | 14 | 100 | 8 | 1 |
| U201.053.R | 5 | 14 | 120 | 8 | 1 |
| U201.054.R | 5 | 25 | 70 | 8 | 1 |
| U201.055.R | 5 | 25 | 100 | 8 | 1 |
| U201.056.R | 5 | 40 | 120 | 8 | 1 |
| U201.060.R | 6 | 14 | 70 | 8 | 1 |
| U201.061.R | 6 | 40 | 100 | 8 | 1 |
| U201.062.R | 6 | 14 | 100 | 8 | 1 |
| U201.063.R | 6 | 25 | 70 | 8 | 1 |
| U201.070.R | 7 | 14 | 70 | 8 | 1 |
| U201.080.R | 8 | 14 | 80 | 8 | 1 |
| U201.081.R | 8 | 30 | 100 | 8 | 1 |
| U201.082.R | 8 | 14 | 100 | 8 | 1 |
| U201.083.R | 8 | 14 | 120 | 8 | 1 |
| U201.084.R | 8 | 25 | 80 | 8 | 1 |
| U201.085.R | 8 | 25 | 120 | 8 | 1 |
| U201.090.R | 9 | 14 | 80 | 8 | 1 |
| U201.100.R | 10 | 14 | 80 | 8 | 1 |
| U201.101.R | 10 | 14 | 100 | 8 | 1 |
| U201.102.R | 10 | 14 | 120 | 8 | 1 |
| U201.120.R | 12 | 14 | 80 | 8 | 1 |
| U211.030.R | 3 | 12 | 60 | 6 | 1 |
| U211.040.R | 4 | 12 | 60 | 6 | 1 |
| U211.050.R | 5 | 14 | 60 | 6 | 1 |
| U211.060.R | 6 | 14 | 60 | 6 | 1 |
| U211.061.R | 6 | 27 | 70 | 6 | 1 |
| U221.030.R | 3 | 12 | 60 | 10 | 1 |
| U221.040.R | 4 | 12 | 60 | 10 | 1 |
| U221.050.R | 5 | 14 | 60 | 10 | 1 |
| U221.060.R | 6 | 14 | 60 | 10 | 1 |
| U221.080.R | 8 | 14 | 80 | 10 | 1 |
| U221.100.R | 10 | 14 | 80 | 10 | 1 |
| U221.101.R | 10 | 14 | 120 | 10 | 1 |
| U221.120.R | 12 | 14 | 80 | 10 | 1 |

HS UPCUT SPIRAL BITS FOR ALUMINIUM Z=1

ART. U202

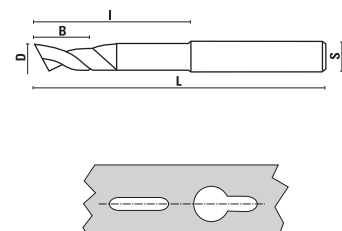

- Manufactured in HS 5% cobalt
- Used for alu profiles
- Plunging and routing
- Use with lubricant
- Reduced throat execution for a better chip ejection

| RH rotation | D | B/l | L | S | Z |
|-------------|----|-------|-----|----|---|
| U202.040.R | 4 | 16/55 | 90 | 8 | 1 |
| U202.050.R | 5 | 14/35 | 80 | 8 | 1 |
| U202.051.R | 5 | 14/35 | 120 | 8 | 1 |
| U202.052.R | 5 | 16/55 | 90 | 8 | 1 |
| U202.053.R | 5 | 18/35 | 100 | 8 | 1 |
| U202.054.R | 5 | 20/45 | 100 | 8 | 1 |
| U202.055.R | 5 | 20/55 | 80 | 10 | 1 |
| U202.056.R | 5 | 20/55 | 100 | 10 | 1 |
| U202.060.R | 6 | 14/55 | 85 | 8 | 1 |
| U202.061.R | 6 | 14/35 | 80 | 8 | 1 |
| U202.062.R | 6 | 14/45 | 90 | 8 | 1 |
| U202.063.R | 6 | 20/55 | 100 | 10 | 1 |
| U202.080.R | 8 | 14/60 | 80 | 8 | 1 |
| U202.081.R | 8 | 14/90 | 120 | 8 | 1 |
| U202.082.R | 8 | 14/70 | 100 | 8 | 1 |
| U202.083.R | 8 | 30/70 | 100 | 8 | 1 |
| U202.100.R | 10 | 14/60 | 80 | 10 | 1 |
| U202.101.R | 10 | 14/70 | 100 | 10 | 1 |
| U202.102.R | 10 | 14/95 | 120 | 10 | 1 |
| U202.103.R | 10 | 30/70 | 100 | 10 | 1 |

SET FOR ALU

ART. X015



Wooden box

| Item |
|--------------------|
| X015.009.R |
| 9-pcs set for alu: |
| U201.030.R |
| U201.040.R |
| U201.050.R |
| U201.060.R |
| U201.080.R |
| U201.100.R |
| U202.050.R |
| U202.060.R |
| U202.080.R |

HS UPCUT SPIRAL BITS FOR ALUMINIUM Z=1, KleinDIA® COATED

ART. U201.KD



KleinDIA® coating for excellent performance

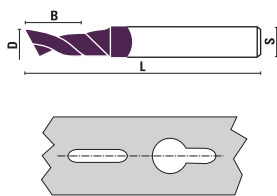

- Manufactured in HS 5% cobalt
- Polished and coated cutting edge for improved chip evacuation and less friction for excellent performance
- Used for alu profiles
- Plunging and routing
- Use with lubricant

| RH rotation | D | B | L | S |
|-------------------------|----|----|-----|---|
| U201.040.RKD NEW | 4 | 12 | 60 | 8 |
| U201.050.RKD NEW | 5 | 14 | 70 | 8 |
| U201.060.RKD NEW | 6 | 14 | 70 | 8 |
| U201.080.RKD NEW | 8 | 14 | 70 | 8 |
| U201.081.RKD NEW | 8 | 30 | 100 | 8 |
| U201.100.RKD NEW | 10 | 14 | 80 | 8 |

HS UPCUT SPIRAL BITS FOR ALUMINIUM Z=1 LONG TYPE, KleinDIA® COATED

ART. U202.KD



KleinDIA® coating for excellent performance

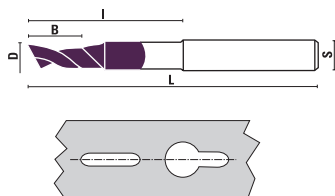

- Manufactured in HS 5% cobalt
- Polished and coated cutting edge for improved chip evacuation and less friction for excellent performance
- Used for alu profiles
- Plunging and routing
- Reduced throat execution for a better chip ejection
- Use with lubricant

| RH rotation | D | B/l | L | S |
|-------------------------|----|-------|-----|---|
| U202.050.RKD NEW | 5 | 14/35 | 80 | 8 |
| U202.080.RKD NEW | 8 | 14/60 | 80 | 8 |
| U202.083.RKD NEW | 8 | 30/70 | 100 | 8 |
| U202.102.RKD NEW | 10 | 14/95 | 120 | 8 |

HS DOUBLE DIAMETER SPIRAL BITS FOR ALUMINIUM Z=2

ART. U230

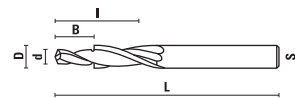

| RH rotation | d/D | B/l | L | S |
|-------------|-----|------|----|---|
| U230.030.R | 3/6 | 8/15 | 60 | 6 |

HS SPECIAL BITS FOR PVC Z=1

ART. U240

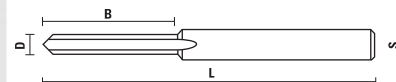

- Plunging
- For working PVC profiles on Elumec, Rotox, Striffler machines

| RH rotation | D | B | L | S |
|-------------|---|----|-----|---|
| U240.050.R | 5 | 35 | 102 | 8 |
| U240.051.R | 5 | 45 | 102 | 8 |
| U240.052.R | 5 | 55 | 102 | 8 |
| U240.060.R | 6 | 30 | 102 | 8 |

HS SPECIAL BITS FOR PVC Z=2

ART. U241

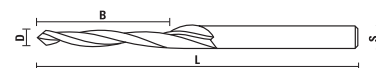

- Through hole execution
- For working PVC profiles on Elumec, Rotox, Striffler machines

| RH rotation | D | B | L | S |
|-------------|---|----|-----|---|
| U241.050.R | 5 | 40 | 100 | 8 |

HS UPCUT SPIRAL CUTTERS FOR ALUMINIUM Z=2-Z=3

ART. U250

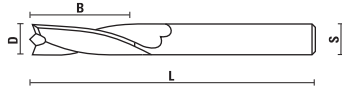

- Manufactured in HS 5% cobalt
- Use on CNC and milling machines
- For working **aluminum** and **ferrous materials**

| RH rotation | D | B | L | S | Z |
|-------------|----|----|-----|----|---|
| U250.040.R | 4 | 12 | 63 | 6 | 2 |
| U250.050.R | 5 | 25 | 68 | 6 | 2 |
| U250.060.R | 6 | 25 | 68 | 6 | 2 |
| U250.080.R | 8 | 25 | 88 | 8 | 2 |
| U250.100.R | 10 | 35 | 95 | 10 | 2 |
| U250.120.R | 12 | 35 | 110 | 12 | 2 |
| U250.140.R | 14 | 37 | 110 | 14 | 3 |
| U250.160.R | 16 | 40 | 123 | 16 | 3 |
| U250.180.R | 18 | 40 | 123 | 18 | 3 |
| U250.200.R | 20 | 45 | 130 | 20 | 3 |

HS DRILLING BITS FOR PVC AND ALUMINIUM WORKING Z=2

ART. U260

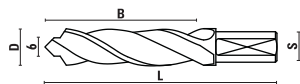

- To be used on our **Trimatic 43/0** boring jigs for mounting cremona bolt on **PVC** and/or **aluminium** doors and windows (Section 16 at page 16.09)

| RH rotation | LH rotation | D | B | L | S |
|-------------|-------------|----|----|----|-------|
| | U260.080.L | 8 | 50 | 76 | 10x20 |
| | U260.100.L | 10 | 50 | 76 | 10x20 |
| U260.120.R | U260.120.L | 12 | 50 | 76 | 10x20 |
| U260.140.R | | 14 | 50 | 76 | 10x20 |

HS DRILLING BITS FOR PVC AND ALUMINIUM WORKING Z=2

ART. U270

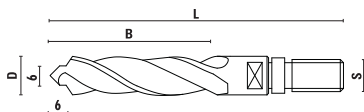

To produce holes for inserting handles on **PVC** and **aluminium** workpieces

| RH rotation | LH rotation | D | B | L | S |
|-------------|-------------|----|----|----|-----|
| | U270.080.L | 8 | 50 | 93 | M10 |
| | U270.100.L | 10 | 50 | 93 | M10 |
| | U270.120.L | 12 | 49 | 93 | M10 |
| U270.120.R | | 12 | 55 | 98 | M10 |
| U270.140.R | | 14 | 55 | 98 | M10 |

HS DOUBLE DIAMETER SPIRAL BITS FOR ALUMINIUM Z=2

ART. U290 - U291

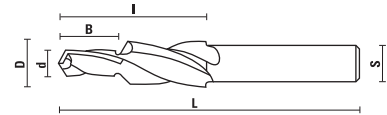

| RH rotation | d/D | B/L | L | S |
|-------------|----------|-------|-----|----|
| U290.055.R | 5,5/11,5 | 12/35 | 100 | 10 |
| U290.060.R | 6/11,5 | 12/35 | 100 | 10 |
| U290.061.R | 6/12 | 15/35 | 80 | 10 |
| U290.062.R | 6/14 | 15/35 | 80 | 10 |
| U290.065.R | 6,5/13,5 | 15/35 | 100 | 10 |
| U290.070.R | 7/13 | 12/35 | 100 | 10 |
| U290.071.R | 7/14 | 12/35 | 100 | 10 |
| U290.072.R | 7/15 | 12/35 | 100 | 10 |
| U290.080.R | 8/15 | 12/35 | 100 | 10 |
| U291.055.R | 5,5/11,5 | 12/35 | 120 | 12 |
| U291.060.R | 6/12 | 12/35 | 100 | 12 |
| U291.065.R | 6,5/11,5 | 12/35 | 100 | 12 |
| U291.066.R | 6,5/12 | 18/45 | 120 | 12 |
| U291.067.R | 6,5/13,5 | 12/35 | 120 | 12 |
| U291.085.R | 8,5/14 | 12/35 | 100 | 12 |

HW INSERT ROUTER BITS FOR PLASTIC MATERIAL

ART. W190.RU – WE190.RU – WG190.RU

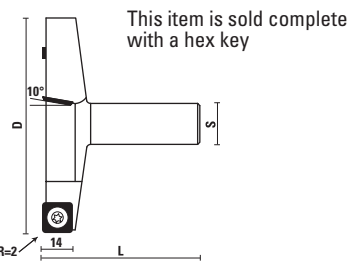

10° shear angle

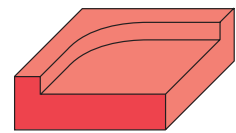
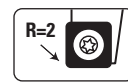

- Used for **surfacing plastic board material** and making deep rabbet (also known as Flycutters - Spoilboard cutters)
- Special insert knives with radius (R=2) for smoother cuts and no risk of marks and scratch.
- **10° shear angle** for better performance
- To be used on machining centres and CNC routers
- Right-hand rotation

| Item | D | B | L | Z | S |
|------------------------|-----------|----|--------|---|-----------------|
| W190.100.RU NEW | 100 | 14 | 80 | 3 | Ø20x55 |
| W190.101.RU NEW | 101,6(4") | 14 | 76(3") | 3 | Ø19,05(3/4")x55 |



Z051.205.R



Z055.107.N



Z052.205.N

| | | | | | |
|-------------------------|--------------|----|------------|---|----------------|
| WE190.800.RU NEW | 80 | 14 | 76 | 3 | Ø12x50 |
| WG190.635.RU NEW | 63,5(2-1/2") | 14 | 70(2-3/4") | 2 | Ø12,7(1/2")x45 |



Z051.020.R



Z055.107.N



Z052.103.N

HOLDING SLEEVES FOR MILLING CUTTER SETS WITH MANUAL INSERTION

ART. YC 320

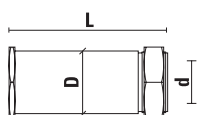

| Item | D | d | L | Type |
|-----------|----|----|-----|--------|
| YC320.160 | 32 | 16 | 100 | Manual |
| YC320.220 | 32 | 22 | 100 | Manual |
| YC320.270 | 32 | 27 | 100 | Manual |

QUICK CHANGE HOLDING SLEEVES FOR MILLING CUTTER SETS

ART. YC 320

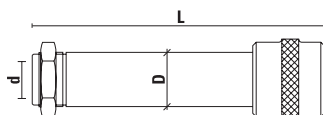

| Item | D | d | L | Type |
|-----------|----|----|-----|--------------|
| YC320.900 | 32 | 27 | 135 | Quick Change |

SPACERS

ART. YD 320

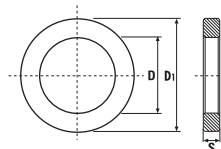

- Use with holding sleeves for aluminium working
- Burnished

| Item | D | D1 | S |
|-----------|----|----|-----|
| YD320.003 | 32 | 45 | 0,3 |
| YD320.005 | 32 | 45 | 0,5 |
| YD320.010 | 32 | 45 | 1 |
| YD320.020 | 32 | 45 | 2 |
| YD320.050 | 32 | 42 | 5 |
| YD320.100 | 32 | 42 | 10 |
| YD320.150 | 32 | 42 | 15 |
| YD320.200 | 32 | 42 | 20 |
| YD320.300 | 32 | 42 | 30 |
| YD320.400 | 32 | 42 | 40 |
| YD320.500 | 32 | 42 | 50 |
| YD320.600 | 32 | 42 | 60 |
| YD320.800 | 32 | 42 | 80 |
| YD320.900 | 32 | 42 | 90 |

HW ALTERNATE TOOTH MILLING CUTTERS

ART. YF 060=YF120

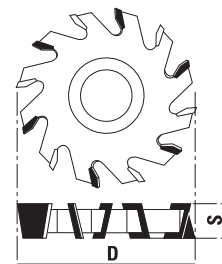

Alternate teeth for better quality of cut

| Item | D | S | F | Z | Item | D | S | F | Z |
|-----------|----|----|----|---|-----------|-----|----|----|----|
| YF060.040 | 60 | 4 | 32 | 6 | YF100.040 | 100 | 4 | 32 | 10 |
| YF060.050 | 60 | 5 | 32 | 6 | YF100.050 | 100 | 5 | 32 | 10 |
| YF060.060 | 60 | 6 | 32 | 6 | YF100.060 | 100 | 6 | 32 | 10 |
| YF060.070 | 60 | 7 | 32 | 6 | YF100.070 | 100 | 7 | 32 | 10 |
| YF060.080 | 60 | 8 | 32 | 6 | YF100.080 | 100 | 8 | 32 | 10 |
| YF060.100 | 60 | 10 | 32 | 6 | YF100.100 | 100 | 10 | 32 | 10 |
| YF060.120 | 60 | 12 | 32 | 6 | YF100.120 | 100 | 12 | 32 | 10 |
| YF060.140 | 60 | 14 | 32 | 6 | YF100.140 | 100 | 14 | 32 | 10 |
| YF060.160 | 60 | 16 | 32 | 6 | YF100.160 | 100 | 16 | 32 | 10 |
| | | | | | YF100.180 | 100 | 18 | 32 | 10 |
| | | | | | YF100.200 | 100 | 20 | 32 | 10 |
| | | | | | YF100.250 | 100 | 25 | 32 | 10 |
| | | | | | YF100.300 | 100 | 30 | 32 | 10 |
| YF070.040 | 70 | 4 | 32 | 8 | | | | | |
| YF070.050 | 70 | 5 | 32 | 8 | | | | | |
| YF070.060 | 70 | 6 | 32 | 8 | | | | | |
| YF070.070 | 70 | 7 | 32 | 8 | YF114.040 | 114 | 4 | 32 | 12 |
| YF070.080 | 70 | 8 | 32 | 8 | YF114.050 | 114 | 5 | 32 | 12 |
| YF070.100 | 70 | 10 | 32 | 8 | YF114.060 | 114 | 6 | 32 | 12 |
| YF070.120 | 70 | 12 | 32 | 8 | YF114.070 | 114 | 7 | 32 | 12 |
| YF070.140 | 70 | 14 | 32 | 8 | YF114.080 | 114 | 8 | 32 | 12 |
| YF070.160 | 70 | 16 | 32 | 8 | YF114.100 | 114 | 10 | 32 | 12 |
| | | | | | YF114.120 | 114 | 12 | 32 | 12 |
| YF080.040 | 80 | 4 | 32 | 8 | YF114.140 | 114 | 14 | 32 | 12 |
| YF080.050 | 80 | 5 | 32 | 8 | YF114.160 | 114 | 16 | 32 | 12 |
| YF080.060 | 80 | 6 | 32 | 8 | YF114.180 | 114 | 18 | 32 | 12 |
| YF080.070 | 80 | 7 | 32 | 8 | YF114.200 | 114 | 20 | 32 | 12 |
| YF080.080 | 80 | 8 | 32 | 8 | YF114.250 | 114 | 25 | 32 | 12 |
| YF080.100 | 80 | 10 | 32 | 8 | YF114.300 | 114 | 30 | 32 | 12 |
| YF080.120 | 80 | 12 | 32 | 8 | | | | | |
| YF080.140 | 80 | 14 | 32 | 8 | | | | | |
| YF080.160 | 80 | 16 | 32 | 8 | YF120.040 | 120 | 4 | 32 | 14 |
| YF080.180 | 80 | 18 | 32 | 8 | YF120.050 | 120 | 5 | 32 | 14 |
| YF080.200 | 80 | 20 | 32 | 8 | YF120.060 | 120 | 6 | 32 | 14 |
| | | | | | YF120.070 | 120 | 7 | 32 | 14 |
| YF090.040 | 90 | 4 | 32 | 8 | YF120.080 | 120 | 8 | 32 | 14 |
| YF090.050 | 90 | 5 | 32 | 8 | YF120.100 | 120 | 10 | 32 | 14 |
| YF090.060 | 90 | 6 | 32 | 8 | YF120.120 | 120 | 12 | 32 | 14 |
| YF090.070 | 90 | 7 | 32 | 8 | YF120.140 | 120 | 14 | 32 | 14 |
| YF090.080 | 90 | 8 | 32 | 8 | YF120.160 | 120 | 16 | 32 | 14 |
| YF090.100 | 90 | 10 | 32 | 8 | YF120.180 | 120 | 18 | 32 | 14 |
| YF090.120 | 90 | 12 | 32 | 8 | YF120.200 | 120 | 20 | 32 | 14 |
| YF090.140 | 90 | 14 | 32 | 8 | YF120.250 | 120 | 25 | 32 | 14 |
| YF090.160 | 90 | 16 | 32 | 8 | YF120.300 | 120 | 30 | 32 | 14 |
| YF090.180 | 90 | 18 | 32 | 8 | | | | | |
| YF090.200 | 90 | 20 | 32 | 8 | | | | | |

SPECIAL UNITS FOR ALUMINIUM-PROFILES

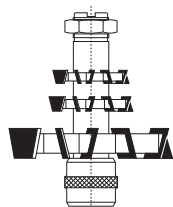

- PRODUCED ON REQUEST
- PLEASE SEND US YOUR INQUIRY WITH TECHNICAL INFORMATION RELATED

| Item | Description |
|-------------|---|
| ART. YG 000 | For alu-profiles "ALL. CO" |
| ART. YG 001 | For alu-profiles "ALCAN" |
| ART. YG 002 | For alu-profiles "EQUIPE" |
| ART. YG 003 | For alu-profiles "ESA ALLUMINIO" |
| ART. YG 004 | For alu-profiles "DOMAL SER. HYDRO ALLUMINIO" |
| ART. YG 005 | For alu-profiles "INDIVEST / ALPHA" |
| ART. YG 006 | For alu-profiles "JOINT (wood - alu)" |
| ART. YG 007 | For alu-profiles "KIKAU" |
| ART. YG 008 | For alu-profiles "METRA" |
| ART. YG 009 | For alu-profiles "NEW" |
| ART. YG 010 | For alu-profiles "OCMA" |
| ART. YG 011 | For alu-profiles "GLOBAL" |
| ART. YG 012 | For alu-profiles "PANDOLFO - SCHUKO" |
| ART. YG 013 | For alu-profiles "PASSERINI" |
| ART. YG 014 | For alu-profiles "RAI - ALLUMINIA" |
| ART. YG 015 | For alu-profiles "TRAFILERIE EMILIANE" |
| ART. YG 016 | For alu-profiles "ITAL - PLASTICK" |

HW TRIMMING AND SIZING SAWBLADES

ART. FCS

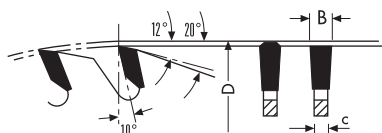

- FZ/TR triple chip teeth trapezoidal
- For table saws
- Ideal for working **ALUCOBOND®**
- For cutting **hardwoods, double sided veneer and laminate board, MDF, hard paper and thermoplastic boards**
- Extra finish and long cutting life
- **No-noise**
- HW grade: KCR06 (K01-C4)

Pin holes: PH02= 2/7/42 + 2/9,5/46,5 + 2/10/60

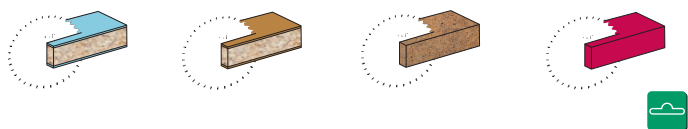

| Item | D | d | B/c | Z | Pin holes |
|--------------|-----|----|---------|-----|-----------|
| FCS250.06030 | 250 | 30 | 3,2/2,2 | 60 | PH02 |
| FCS250.08030 | 250 | 30 | 3,2/2,2 | 80 | PH02 |
| FCS300.07230 | 300 | 30 | 3,2/2,2 | 72 | PH02 |
| FCS300.09630 | 300 | 30 | 3,2/2,2 | 96 | PH02 |
| FCS350.08430 | 350 | 30 | 3,5/2,5 | 84 | PH02 |
| FCS350.11230 | 350 | 30 | 3,5/2,5 | 108 | PH02 |

HW TRIMMING AND SIZING SAWBLADES

ART. FB

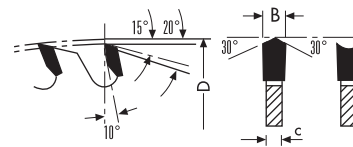

- HZ/DZ inverted "V" and hollow ground teeth
- For cutting boards with **synthetic resincoating, double sided veneer and laminate boards and plywood**
- For panel saws and table saws
- Extra finish and long cutting life
- HW grade: KCR06 (K01-C4)

Pin holes: PH02= 2/7/42 + 2/9,5/46,5 + 2/10/60

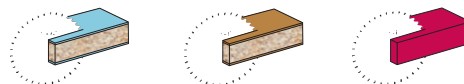

| Item | D | d | B/c | Z | Pin holes |
|-------------|-----|----|---------|----|-----------|
| FB220.04230 | 220 | 30 | 3,2/2,2 | 42 | |
| FB253.04830 | 250 | 30 | 3,2/2,2 | 48 | PH02 |
| FB303.06030 | 300 | 30 | 3,2/2,2 | 60 | PH02 |
| FB350.07230 | 350 | 30 | 3,5/2,5 | 72 | PH02 |

HW SAWBLADES FOR PVC AND PLEXIGLASS

ART. MGS

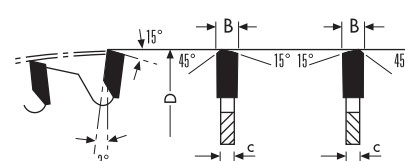

- WZ/FA alternate-trap, teeth
- 3° negative hook angle
- Suitable for **thin plastic, plexiglass, PVC and plywood**
- **No-noise**
- HW grade: KCR06 (K01-C4)

Pin holes: PH02= 2/7/42 + 2/9,5/46,5 + 2/10/60



| Item | D | d | B/c | Z | Pin holes |
|--------------|-----|----|---------|----|-----------|
| MGS250.08030 | 250 | 30 | 2,6/2,0 | 80 | PH02 |
| MGS300.08430 | 300 | 30 | 2,6/2,0 | 84 | PH02 |
| MGS300.09630 | 300 | 30 | 2,6/2,0 | 96 | PH02 |

HW SAWBLADES FOR ALUMINIUM

ART. LA

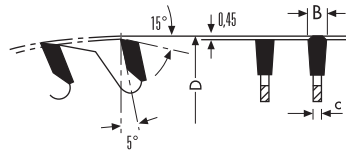

- FZ/TR triple chip teeth
- 5° positive hook angle
- For Alu, PVC and non-ferrous metals. For cutting aluminium profiles and extrusions with thickness of 2-5mm
- For table saws
- = no-noise with a special sound absorbing resin inside the silent slots
- HW grade: HC10 (K10-C3)

* Thin kerf saw blades. Suitable for working on machine without casing.



| Item | D | d | B/c | Z | Pin holes |
|--------------------|-----|----|---------|-----|-----------|
| LA200.06430 | 200 | 30 | 3,2/2,5 | 64 | 2/11/63 |
| LA200.06432 | 200 | 32 | 3,2/2,5 | 64 | 2/11/63 |
| LA250.06030 | 250 | 30 | 3,4/2,6 | 60 | 2/11/63 |
| LA250.06032 | 250 | 32 | 3,4/2,6 | 60 | 2/11/63 |
| LA250.08030 | 250 | 30 | 3,4/2,6 | 80 | 2/11/63 |
| LA250.08032 | 250 | 32 | 3,4/2,6 | 80 | 2/11/63 |
| LA300.07230 | 300 | 30 | 3,4/2,6 | 72 | 2/11/63 |
| LA300.07232 | 300 | 32 | 3,4/2,6 | 72 | 2/11/63 |
| LA300.08430 | 300 | 30 | 3,4/2,6 | 84 | 2/11/63 |
| LA300.08432 | 300 | 32 | 3,4/2,6 | 84 | 2/11/63 |
| LA300.09630 | 300 | 30 | 3,4/2,6 | 96 | 2/11/63 |
| LA300.09632 | 300 | 32 | 3,4/2,6 | 96 | 2/11/63 |
| LA350.08430 | 350 | 30 | 3,4/2,6 | 84 | 2/11/63 |
| LA350.08432 | 350 | 32 | 3,4/2,6 | 84 | 2/11/63 |
| LA350.09630 | 350 | 30 | 3,4/2,6 | 96 | 2/11/63 |
| LA350.09632 | 350 | 32 | 3,4/2,6 | 96 | 2/11/63 |
| LA350.10830 | 350 | 30 | 3,4/2,6 | 108 | 2/11/63 |
| LA350.10832 | 350 | 32 | 3,4/2,6 | 108 | 2/11/63 |
| LA400.09630 | 400 | 30 | 4,0/3,2 | 96 | 2/11/63 |
| LA400.09632 | 400 | 32 | 4,0/3,2 | 96 | 2/11/63 |
| LA400.12030 | 400 | 30 | 4,0/3,2 | 120 | 2/11/63 |
| LA400.12032 | 400 | 32 | 4,0/3,2 | 120 | 2/11/63 |
| LA400.19632 * NEW | 400 | 32 | 3,6/3,0 | 96 | 2/11/63 |
| LA420.09630 NEW | 420 | 30 | 4,0/3,2 | 96 | 2/11/63 |
| LA420.09632 | 420 | 32 | 4,0/3,2 | 96 | 2/11/63 |
| LA450.09630 | 450 | 30 | 4,0/3,2 | 96 | 2/11/63 |
| LA450.09632 | 450 | 32 | 4,0/3,2 | 96 | 2/11/63 |
| LA450.10830 | 450 | 30 | 4,0/3,2 | 108 | 2/11/63 |
| LA450.10832 | 450 | 32 | 4,0/3,2 | 108 | 2/11/63 |
| LA450.19632 * NEW | 450 | 32 | 3,8/3,2 | 96 | 2/11/63 |
| LA500.12030 | 500 | 30 | 4,6/3,6 | 120 | 2/11/63 |
| LA500.12032 | 500 | 32 | 4,6/3,6 | 120 | 2/11/63 |
| LA500.12130 NEW | 500 | 30 | 4,0/3,2 | 120 | 2/11/63 |
| LA500.12132 * | 500 | 32 | 4,0/3,2 | 120 | 2/11/63 |
| LA550.14030 | 550 | 30 | 4,6/3,6 | 140 | 2/11/63 |
| LA600.14030 | 600 | 30 | 4,6/3,6 | 140 | 2/11/63 |

HW SAWBLADES FOR ALUMINIUM

ART. LB

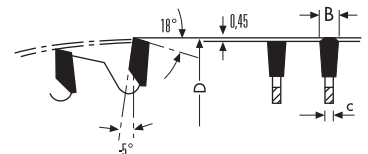

- FZ/TR triple chip teeth
- 5° negative hook angle
- For Alu, PVC and non-ferrous metals
- For table saws
- = No-noise with a special sound absorbing material inside of silent slots
- HW grade: HC10 (K10-C3)

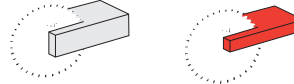

| Item | D | d | B/c | Z | Pin holes |
|-------------|-----|----|---------|-----|-----------|
| LB200.06430 | 200 | 30 | 3,2/2,6 | 64 | 2/11/63 |
| LB200.06432 | 200 | 32 | 3,2/2,6 | 64 | 2/11/63 |
| LB250.06030 | 250 | 30 | 3,4/2,6 | 60 | 2/11/63 |
| LB250.08030 | 250 | 30 | 3,4/2,6 | 80 | 2/11/63 |
| LB250.08032 | 250 | 32 | 3,4/2,6 | 80 | 2/11/63 |
| LB300.07230 | 300 | 30 | 3,4/2,6 | 72 | 2/11/63 |
| LB300.08430 | 300 | 30 | 3,4/2,6 | 84 | 2/11/63 |
| LB300.08432 | 300 | 32 | 3,4/2,6 | 84 | 2/11/63 |
| LB300.09630 | 300 | 30 | 3,4/2,6 | 96 | 2/11/63 |
| LB300.09632 | 300 | 32 | 3,4/2,6 | 96 | 2/11/63 |
| LB350.08430 | 350 | 30 | 3,4/2,6 | 84 | 2/11/63 |
| LB350.08432 | 350 | 32 | 3,4/2,6 | 84 | 2/11/63 |
| LB350.09630 | 350 | 30 | 3,4/2,6 | 96 | 2/11/63 |
| LB350.09632 | 350 | 32 | 3,4/2,6 | 96 | 2/11/63 |
| LB350.10830 | 350 | 30 | 3,4/2,6 | 108 | 2/11/63 |
| LB350.10832 | 350 | 32 | 3,4/2,6 | 108 | 2/11/63 |
| LB400.09630 | 400 | 30 | 4,0/3,2 | 96 | 2/11/63 |
| LB400.09632 | 400 | 32 | 4,0/3,2 | 96 | 2/11/63 |
| LB400.12030 | 400 | 30 | 4,0/3,2 | 120 | 2/11/63 |
| LB400.12032 | 400 | 32 | 4,0/3,2 | 120 | 2/11/63 |
| LB450.09630 | 450 | 30 | 4,0/3,2 | 96 | 2/11/63 |
| LB450.09632 | 450 | 32 | 4,0/3,2 | 96 | 2/11/63 |
| LB450.10830 | 450 | 30 | 4,0/3,2 | 108 | 2/11/63 |
| LB450.10832 | 450 | 32 | 4,0/3,2 | 108 | 2/11/63 |
| LB500.12030 | 500 | 30 | 4,6/3,6 | 120 | 2/11/63 |
| LB500.12032 | 500 | 32 | 4,6/3,6 | 120 | 2/11/63 |
| LB550.14030 | 550 | 30 | 4,6/3,6 | 140 | 2/11/63 |
| LB600.14030 | 600 | 30 | 4,6/3,6 | 140 | 2/11/63 |

RPM suggested referred to the blade diameter

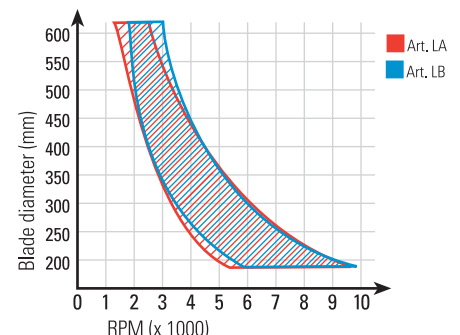

Other sizes are available upon request

HW SAWBLADES FOR PVC



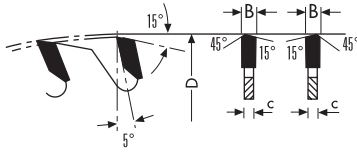



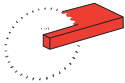

ART. LE



- **WZ/FA** alternate-trap, teeth
- Especially made for cutting **PVC** and thin plastic material
-  = **no-noise with a special sound absorbing resin inside the silent slots**
- For table saws
- **HW grade: KCR06 (K01-C4)**

Pin holes: **PH01**= 2/10/60



| Item | D | d | B/c | Z | Pin holes |
|--|-----|----|---------|-----|-----------|
| LE200.06430  NEW | 200 | 30 | 3,0/2,5 | 64 | |
| LE250.08030  NEW | 250 | 30 | 3,0/2,5 | 80 | PH01 |
| LE300.09630  NEW | 300 | 30 | 3,0/2,5 | 96 | PH01 |
| LE350.10830  NEW | 350 | 30 | 3,2/2,5 | 108 | PH01 |
| LE400.12030  NEW | 400 | 30 | 3,6/3,0 | 120 | 2/11/63 |
| LE450.12030  NEW | 450 | 30 | 3,8/3,2 | 120 | 2/11/63 |
| LE500.12030  NEW | 500 | 30 | 4,0/3,2 | 120 | 2/11/63 |
| LE550.14030  NEW | 550 | 30 | 4,2/3,5 | 140 | 2/11/63 |
| LE600.14030  NEW | 600 | 30 | 4,2/3,5 | 140 | 2/11/63 |



CONTACT US
 (+39) 0721 28950
 info@sistemiklein.com

Insert router bits and DP router bits



9



Spare Parts



10



Reversible knives
and knives for planers



11



Sawblades

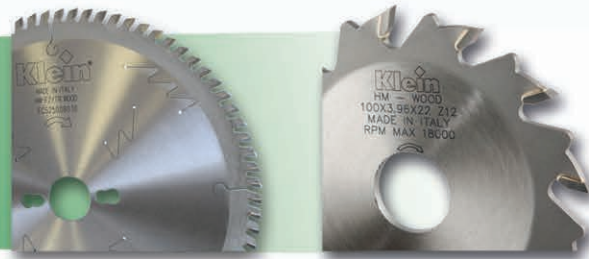

12



Cutterheads



13



Lubricants,
diamond grinding wheels,
diamond stones



14



Measuring instruments



15



Special devices



16



Klein[®]

Insert router bits and DP router bits



9

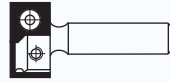

HW INSERT FLUSH TRIM BITS Z=2
Page 9.05

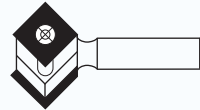

HW INSERT ANGLE BITS Z=2
Page 9.05

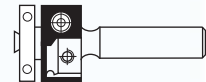

HW INSERT FLUSH TRIM BITS
WITH BALL BEARING GUIDE Z=2
Page 9.05

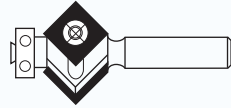

HW INSERT FLUSH TRIM BITS
WITH BALL BEARING GUIDE Z=2
Page 9.05

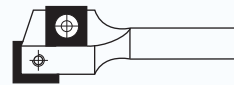

HW INSERT FLUSH BITS Z=2+1
Page 9.05



HW INSERT FLUSH BITS Z=2+1
Page 9.06



HW INSERT FLUSH TRIMMING BITS Z=2
Page 9.06



HW INSERT FLUSH TRIMMING BITS WITH
LOWER DOUBLE BALL BEARINGS Z=2
Page 9.06

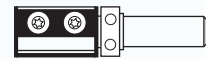

HW FLUSH INSERT
TRIMMING BITS Z=2
Page 9.06



HW INSERT FLUSH TRIMMING BITS WITH
UPPER DOUBLE BALL BEARINGS Z=2
Page 9.06



HW INSERT PLUNGE
ROUTER BITS Z=1 "VERSOFIX"
Page 9.07

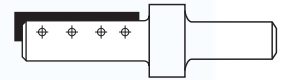

HW INSERT PLUNGE ROUTER BITS
Z=1 "VERSOFIX"
Page 9.07



HW INSERT PLUNGE ROUTER BITS Z=1
"VERSOFIX"
Page 9.08



HW INSERT FLUSH TRIM
BITS Z=2 "VERSOFIX"
Page 9.08



HW INSERT FLUSH TRIM
BITS Z=2 "VERSOFIX"
Page 9.08

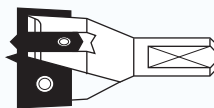

HW INSERT BORING BITS Z=2+2
Page 9.08



HW INSERT PLUNGE
ROUTER CUTTERS Z=1
Page 9.08

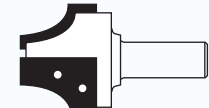

HW INSERT PROFILE CUTTERS,
GROUP 1
Page 9.09

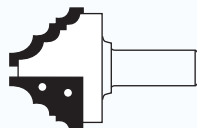

HW INSERT PROFILE CUTTERS,
GROUP 2
Page 9.09



HW INSERT COMPRESSION
ROUTER CUTTERS
Page 9.09



HW INSERT COMPRESSION
ROUTER CUTTER
Page 9.09

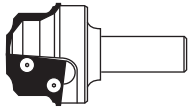

HW INSERT ROUTER BITS FOR CABINET DOORS Z=2
Page 9.10

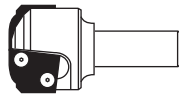

HW INSERT ROUTER BITS FOR CABINET DOORS Z=2
Page 9.10

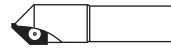

HW INSERT ROUTER BITS FOR DECORATION AND ENGRAVING Z=1
Page 9.11



COMPLETE SET FOR DECORATING AND ENGRAVING
Page 9.11



COMPLETE CUTTERS SET FOR CABINET DOORS
Page 9.12

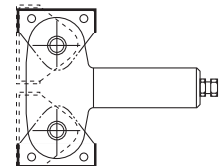

HW INSERT VARI-ANGLE ROUTER CUTTERS 1° Z=2
Page 9.13

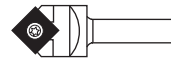

HW INSERT ROUTER BITS FOR ENGRAVINGS Z=1
Page 9.13

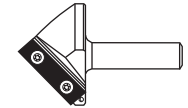

HW INSERT ROUTER BITS FOR ENGRAVINGS Z=2
Page 9.13

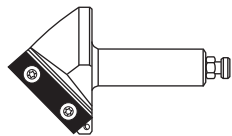

HW INSERT V-GROOVE ROUTER BITS Z=1
Page 9.13



HW INSERT ROUTER BITS FOR LOCKS Z=2
Page 9.14



HW INSERT ROUTER BITS FOR LOCKS Z=2 HEAVY METAL TOOL BODY
Page 9.14

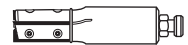

HW INSERT ROUTER BITS LOCKS Z=3
Page 9.14

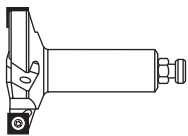

HW INSERT ROUTER BITS FOR PLANING AND RABBETING Z=2+2
Page 9.14

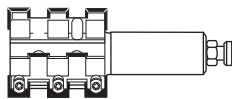

HW INSERT ROUTER CUTTERS, ROUGHING Z=4
Page 9.15

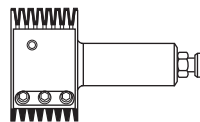

HW INSERT FINGER JOINT ROUTER CUTTERS Z=2
Page 9.15

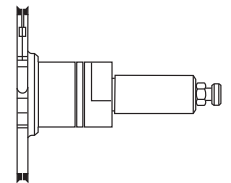

HW INSERT ADJUSTABLE ROUTER CUTTERS FOR GROOVING
Page 9.15

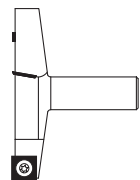

HW INSERT ROUTER BITS FOR PLANING AND RABBETING
Pag. 9.15

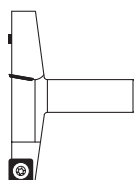

HW INSERT ROUTER BITS FOR PLASTIC MATERIAL
Page 9.15



HW INSERT FLUSH TRIMMING BITS Z=1
Page 9.16

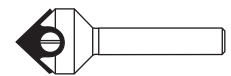

HW INSERT V-GROOVING BITS Z=1
Page 9.16

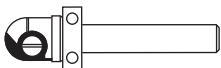

HW INSERT CORE BOX BITS WITH UPPER BALL BEARING Z=1
Page 9.16



HW INSERT FLUSH TRIMMING BITS WITH BALL BEARING
Page 9.16

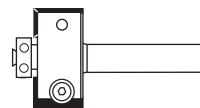

HW INSERT FLUSH TRIMMING BITS WITH BALL BEARING Z=2
Page 9.16

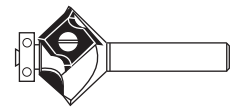

HW INSERT FLUSH TRIMMING BITS WITH BALL BEARING Z=2
Page 9.17

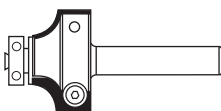

HW INSERT CORNER ROUNDING BITS WITH BALL BEARING Z=2
Page 9.17

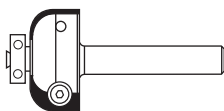

HW INSERT COVER BITS WITH BALL BEARING Z=2
Page 9.17

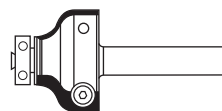

HW INSERT OGEE BITS WITH BALL BEARING Z=2
Page 9.17



6 PIECE INSERT ROUTER BITS "SET"
Page 9.17



6 PIECE INSERT ROUTER BITS "SET"
Page 9.17

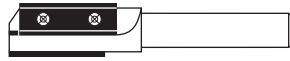

HW INSERT ROUTER BITS Z=2+1
Page 9.18



HW INSERT ROUTER BITS Z=2
WITH STRAIGHT CUTTERS
Page 9.18

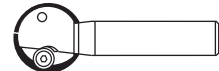

HW INSERT BALL SLOT ROUTER
BITS Z=2
Page 9.18

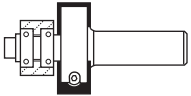

HW INSERT REBATE BITS Z=2
Page 9.18

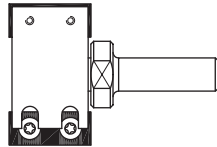

HW INSERT RABBETING BITS Z=2
Pag. 9.19

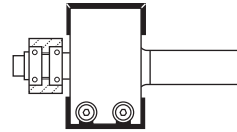

HW INSERT REBATE BITS Z=2
Page 9.20

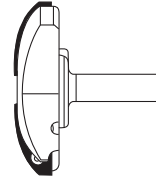

HW INSERT PROFILE RAISED
PANEL ROUTER CUTTERS Z=2
Page 9.20

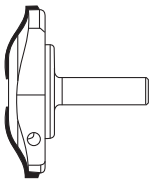

HW INSERT PROFILE RAISED PANEL
ROUTER CUTTERS Z=2
Page 9.21

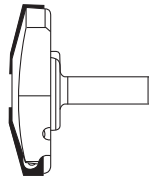

HW INSERT PROFILE RAISED PANEL
ROUTER CUTTERS Z=2
Page 9.21

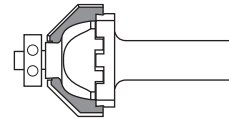

HW INTERCHANGEABLE INSERT
ROUTER BITS "NOVA SYSTEM" Z=2
Page 9.22 + 9.24

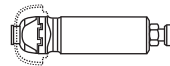

HW INSERT ROUTER BITS
"NOVA SYSTEM" Z=2
Page 9.25

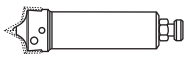

HW INSERT ROUTER BITS
"NOVA SYSTEM" Z=2
Page 9.25

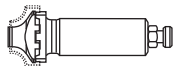

HW INSERT ROUTER BITS
"NOVA SYSTEM" Z=2
Page 9.25



DP ROUTER BITS
Page 9.26

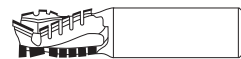

DP ROUTER BITS
Page 9.26

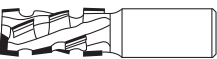

DP ROUTER BITS
Page 9.26



DP ROUTER BITS Z=1
Page 9.27



DP ROUTER BITS Z=1
Page 9.27

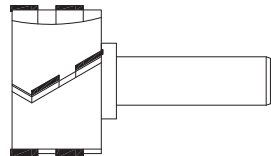

DP ROUTER CUTTERS WITH
40° SHEAR ANGLE
Pag. 9.27

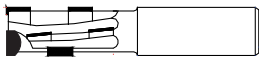

DP ROUTER BITS H=1,5
Page 9.27

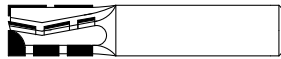

DP ROUTER BITS FOR NESTING OPERATION
Page 9.28



DP DOWEL DRILLS
Page 9.28



DP THROUGH-HOLE DRILL BITS
Page 9.28

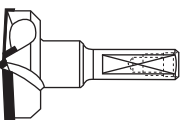

DP HINGE BORING BITS
Page 9.28



DP GROOVE CUTTER FOR
"LAMELLO" JOINTS
Pag. 9.29



DP SAW BLADES FOR CUTTING
ABRASIVE MATERIALS
Pag. 9.29



DP SAWBLADES
Page 9.30



• DP CONICAL SCORING SAWBLADES
• Page 9.30

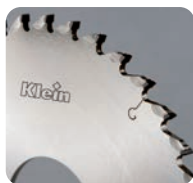

• DP ADJUSTABLE SCORING SAWBLADES
• Page 9.30



• DP PANEL SIZING SAWBLADES
• Page 9.31

HW INSERT FLUSH TRIM BITS Z=2

ART. W101 - W102

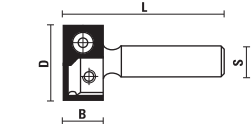

This item is sold complete with a torx key

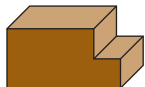

| S Ø 6 | S Ø 8 | D | B | L |
|------------|------------|----|----|----|
| W101.190.R | W102.190.R | 19 | 12 | 55 |



HW INSERT ANGLE BITS Z=2

ART. W103 - W104

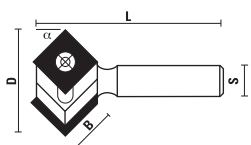

This item is sold complete with a torx key

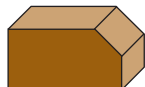

| S Ø 6 | S Ø 8 | D | α | B | L |
|------------|------------|----|-----|----|----|
| W103.240.R | W104.240.R | 24 | 22° | 12 | 55 |
| W103.260.R | W104.260.R | 26 | 30° | 12 | 55 |
| W103.290.R | W104.290.R | 29 | 45° | 12 | 55 |



HW INSERT FLUSH TRIM BITS WITH BALL BEARING GUIDE Z=2

ART. W105 - W106

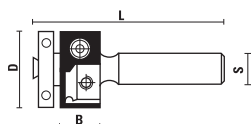

This item is sold complete with a torx key

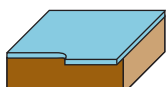

| S Ø 6 | S Ø 8 | D | B | L |
|------------|------------|----|----|----|
| W105.190.R | W106.190.R | 19 | 12 | 65 |



HW INSERT FLUSH TRIM BITS WITH BALL BEARING GUIDE Z=2

ART. W107 - W108

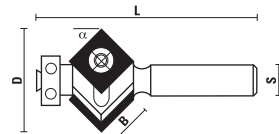

This item is sold complete with a torx key

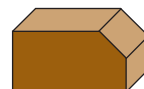

| S Ø 6 | S Ø 8 | D | α | B | L (W107) | L (W108) |
|------------|------------|----|-----|----|----------|----------|
| W107.220.R | W108.220.R | 22 | 10° | 12 | 55 | 70 |
| W107.240.R | W108.240.R | 24 | 22° | 12 | 55 | 70 |
| W107.260.R | W108.260.R | 26 | 30° | 12 | 55 | 70 |

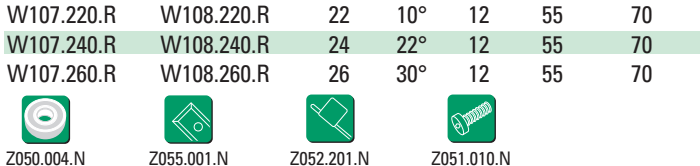

| | | | | | | |
|------------|------------|----|-----|----|----|----|
| W107.290.R | W108.290.R | 29 | 45° | 12 | 55 | 70 |
|------------|------------|----|-----|----|----|----|



HW INSERT FLUSH BITS Z=2+1

ART. W109 - W110

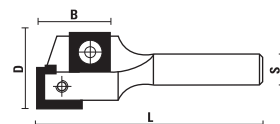

This item is sold complete with a torx key

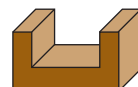

With T.C.T. plunging edge

| S Ø 6 | S Ø 8 | D | B | L |
|------------|------------|----|----|----|
| W109.160.R | | 16 | 20 | 50 |
| | W110.160.R | 16 | 20 | 70 |
| W109.180.R | W110.180.R | 18 | 20 | 50 |
| W109.200.R | W110.200.R | 20 | 20 | 50 |
| W109.220.R | W110.220.R | 22 | 20 | 50 |



HW INSERT FLUSH BITS Z=2+1

ART. W111 - W112

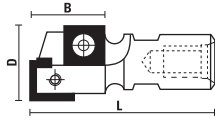

This item is sold complete with a torx key

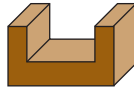

With T.C.T. plunging edge

| S M12x1 | S M10x1,5 | D | B | L |
|------------|------------|----|----|----|
| W111.150.R | W112.150.R | 15 | 20 | 65 |
| W111.160.R | W112.160.R | 16 | 20 | 65 |
| W111.180.R | W112.180.R | 18 | 20 | 65 |
| W111.200.R | W112.200.R | 20 | 20 | 65 |
| W111.220.R | W112.220.R | 22 | 20 | 65 |



Z055.001.N



Z052.201.N



Z051.010.R

HW INSERT FLUSH TRIMMING BITS Z=2

ART. W113 - W114

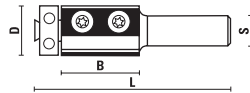

This item is sold complete with a torx key

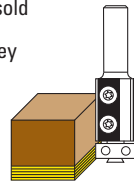

Lower ball bearing

| Item | D | B | L | Z | S |
|------------|----|----|-----|---|----|
| W113.190.R | 19 | 30 | 70 | 2 | 8 |
| W114.190.R | 19 | 30 | 80 | 2 | 12 |
| W114.191.R | 19 | 50 | 100 | 2 | 12 |



Z055.008.N
(B=30)



Z055.010.N
(B=50)



Z050.006.N



Z052.201.N



Z051.017.R
(for ball bearing)



Z051.010.R
(for knives)

HW INSERT FLUSH TRIMMING BITS WITH LOWER DOUBLE BALL BEARINGS Z=2

ART. W114

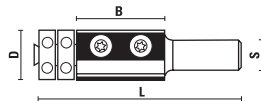

This item is sold complete with a torx key

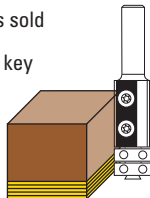

Double ball bearings for more precise trimming results

| Item | D | B | L | Z | S |
|-----------------------|----|----|-----|---|----|
| W114.192.R NEW | 19 | 50 | 100 | 2 | 12 |



Z055.010.N
(B=50)



Z050.006.N



Z052.201.N



Z051.017.R
(for ball bearing)



Z051.010.R
(for knives)

HW INSERT FLUSH TRIMMING BITS Z=2

ART. W115 - W116

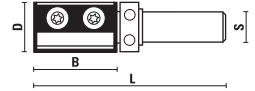

This item is sold complete with a torx key

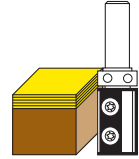

Upper ball bearing

| Item | D | B | L | Z | S |
|------------|----|----|-----|---|----|
| W115.190.R | 19 | 30 | 70 | 2 | 8 |
| W116.190.R | 19 | 30 | 80 | 2 | 12 |
| W116.191.R | 19 | 50 | 100 | 2 | 12 |



Z055.008.N
(B=30)



Z055.010.N
(B=50)



Z050.012.N



Z052.201.N



Z051.017.R
(for ball bearing)



Z051.010.R
(for knives)

HW INSERT FLUSH TRIMMING BITS WITH UPPER DOUBLE BALL BEARINGS Z=2

ART. W116

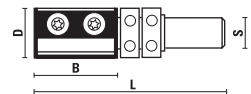

This item is sold complete with a torx key

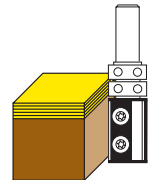

Double ball bearings for more precise trimming results

| Item | D | B | L | Z | S |
|-----------------------|----|----|-----|---|----|
| W116.192.R NEW | 19 | 50 | 100 | 2 | 12 |



Z055.010.N
(B=50)



Z050.012.N



Z052.201.N



Z051.010.R
(for knives)

VERSOFIX CUTTERS AND KNIVES

The best single flute replaceable tip straight cutters

The **VERSOFIX** tools and relating replaceable tips, due to their special design, give excellent result in high volume production and are suitable for use in all types of machines.

The insert knives are treated with a special coating ensuring the possibility to work also tough materials, i.e. laminated worktops or glass-reinforced plastic panels.

In the solid wood working there isn't any better solution when working with cutters with small shank diameter (Ø8, Ø10, Ø12).

The **"Kawedur"** coating ensures a better chip flow and makes the life of the knives minimum twice longer than any other type of coating (TIN/TIC).

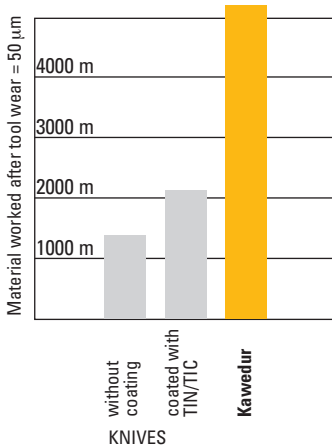
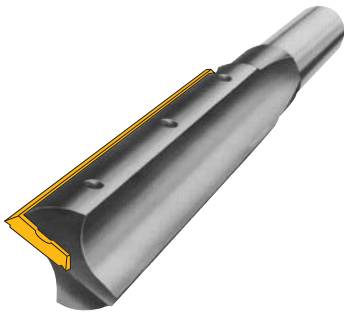

WORKING:
melamine coated chipboard

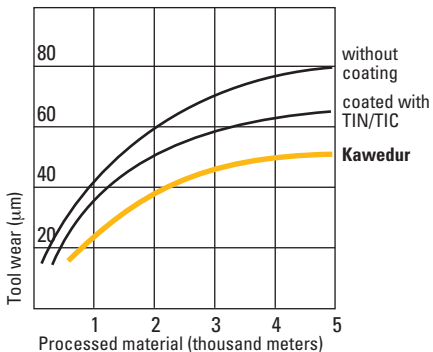

WORKING PARAMETERS:

RPM n=18.000
Cutting speed vs=14,5 m/sec
Feed speed vf=6 m/min

HW INSERT PLUNGE ROUTER BITS Z=1 "VERSOFIX"

ART. W120 - W121 - W122

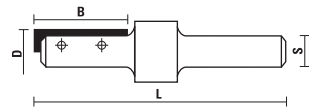

This item is sold complete with a hex key

HW knives with "Kawedur" coating

| S Ø 8 | D | B | L |
|------------|----|----|----|
| W122.080.R | 8 | 20 | 63 |
| W122.100.R | 10 | 20 | 63 |
| W122.120.R | 12 | 20 | 63 |
| W122.140.R | 14 | 30 | 74 |
| W122.150.R | 15 | 30 | 74 |
| W122.160.R | 16 | 30 | 74 |
| W122.180.R | 18 | 30 | 74 |
| W122.200.R | 20 | 30 | 74 |
| W122.220.R | 22 | 30 | 74 |



Z052.101.N



Z052.102.N (For D=14÷22)



Z055.220.N (For D=8÷12)
Z055.221.N (For D=14÷22)
Z055.230.N (For D=12,2÷13,9)
Z055.231.N (For D=14÷22)
Z055.250.N (For D=14÷22)



Z051.102.R (For D=14÷22)

HW INSERT PLUNGE ROUTER BITS Z=1 "VERSOFIX"

ART. W123 - W124 - W125

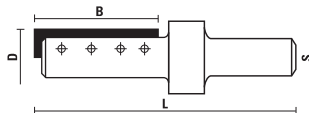

This item is sold complete with a hex key

HW knives with "Kawedur" coating

| S Ø 10x35 | S Ø 12x35 | D | B | L |
|------------|------------|----|----|----|
| W123.080.R | W124.080.R | 8 | 20 | 68 |
| W123.100.R | W124.100.R | 10 | 20 | 68 |
| W123.120.R | W124.120.R | 12 | 20 | 68 |
| | W124.140.R | 14 | 30 | 74 |
| W123.141.R | W124.141.R | 14 | 50 | 94 |
| | W124.150.R | 15 | 30 | 74 |
| | W124.160.R | 16 | 30 | 74 |
| W123.161.R | W124.161.R | 16 | 50 | 94 |
| | W124.180.R | 18 | 30 | 74 |
| W123.181.R | W124.181.R | 18 | 50 | 94 |
| | W124.200.R | 20 | 30 | 74 |
| W123.201.R | W124.201.R | 20 | 50 | 94 |
| | W124.220.R | 22 | 30 | 74 |



Z052.101.N



Z052.102.N (For D=14÷22)



Z055.220.N (For D=8÷12)
Z055.221.N (For D=14÷22)
Z055.230.N (For D=12,2÷13,9)
Z055.231.N (For D=14÷22)
Z055.250.N (For D=14÷22)



Z051.102.R (For D=14÷22)

HW INSERT PLUNGE ROUTER BITS Z=1 "VERSOFIX"

ART. W126 - W127

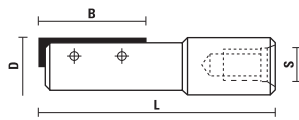

This item is sold complete with a hex key

HW knives with "Kawedur" coating

| S M10x1,5 | S M12x1 | D | B | L |
|------------|------------|----|----|----|
| W126.141.R | W127.141.R | 14 | 50 | 85 |
| W126.161.R | W127.161.R | 16 | 50 | 85 |
| W126.181.R | W127.181.R | 18 | 50 | 85 |
| W126.201.R | W127.201.R | 20 | 50 | 85 |



Z055.250.N (For D=14÷22)



Z051.102.R (For D=14÷22)



Z052.102.N (For D=14÷22)

HW INSERT FLUSH TRIM BITS Z=2 "VERSOFIX"

ART. W138

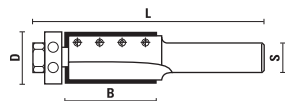

This item is sold complete with a hex key

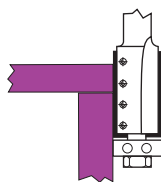

- HW knives with "Kawedur" coating
- For CORIAN®
- Ball bearing with Delrin® ring

| S Ø 12 | D | B | L |
|------------|----|----|----|
| W138.190.R | 19 | 30 | 82 |



Z050.111.N



Z055.230.N



Z051.101.R



Z052.101.N

HW INSERT FLUSH TRIM BITS Z=2 "VERSOFIX"

ART. W138

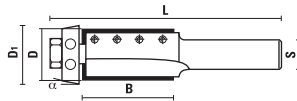

This item is sold complete with a hex key

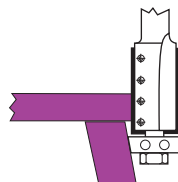

- HW knives with "Kawedur" coating
- For CORIAN®
- 11° ball bearing with Delrin® ring

| S Ø 12 | D | D1 | B | L | α |
|------------|----|----|----|----|-----|
| W138.220.R | 19 | 22 | 30 | 82 | 11° |



Z050.111.N



Z055.230.N



Z051.101.R



Z052.101.N

HW INSERT BORING BITS Z=2+2

ART. W140

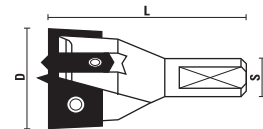

This item is sold complete with a torx key

| RH rotation | LH rotation | D | L | S | Spare knife |
|-------------|-------------|----|----|-------|-------------|
| W140.250.R | W140.250.L | 25 | 57 | 10x26 | Z055.125.N |
| W140.260.R | W140.260.L | 26 | 57 | 10x26 | Z055.126.N |
| W140.300.R | W140.300.L | 30 | 57 | 10x26 | Z055.130.N |
| W140.350.R | W140.350.L | 35 | 57 | 10x26 | Z055.135.N |
| W140.400.R | W140.400.L | 40 | 57 | 10x26 | Z055.140.N |



Z051.010.R
Screw for knives



Z051.011.R
Screw for spurs



Z051.304.R
Screw for centre point



Z055.100.N



Z055.101.N



Z052.201.N

HW INSERT PLUNGE ROUTER CUTTERS Z=1

ART. W155

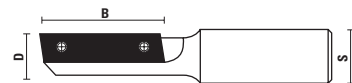

This item is sold complete with a torx key

Spare knives suitable for plunging

| Item | D | B | S | Z |
|------------------------|----|----|--------|---|
| W155.160.R selling out | 16 | 30 | Ø20x50 | 1 |
| W155.161.R | 16 | 50 | Ø20x50 | 1 |
| W155.180.R selling out | 18 | 30 | Ø20x50 | 1 |
| W155.181.R | 18 | 50 | Ø20x50 | 1 |
| W155.200.R selling out | 20 | 30 | Ø20x50 | 1 |
| W155.201.R | 20 | 50 | Ø20x50 | 1 |
| W155.220.R selling out | 22 | 30 | Ø20x50 | 1 |
| W155.221.R | 22 | 50 | Ø20x50 | 1 |



Z055.423.N (B=30 D=16)
Z055.425.N (B=50 D=16)
Z055.430.N (B=30)
Z055.450.N (B=50)



Z051.210.R (B=30)



Z051.211.R (B=50)



Z052.201.N

HW INSERT PROFILE CUTTERS, GROUP 1

ART. W160

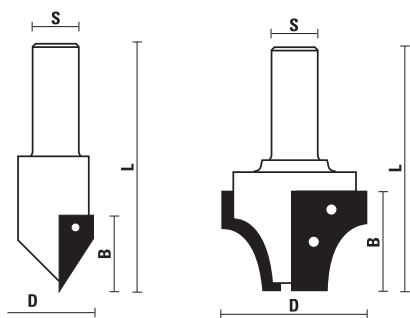

- From \varnothing 20 to \varnothing 39 z=1
- From \varnothing 40 to \varnothing 80 z=2

| D | B | D | B |
|----|----|----|----|
| 20 | 25 | 60 | 30 |
| 30 | 25 | 60 | 40 |
| 30 | 30 | 60 | 50 |
| 40 | 20 | 70 | 30 |
| 40 | 30 | 70 | 40 |
| 40 | 40 | 70 | 50 |
| 50 | 30 | 80 | 30 |
| 50 | 40 | 80 | 40 |
| 50 | 50 | 80 | 50 |

SPARE KNIVES QUOTED ON REQUEST

Price depends on the diameter and length of the cutters.
For a specific quote a detailed drawing or a sample are required.

HW INSERT PROFILE CUTTERS, GROUP 2

ART. W161

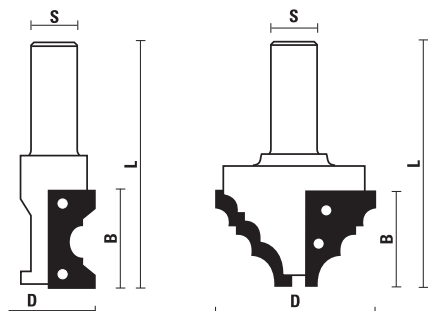

- From \varnothing 20 to \varnothing 39 z=1
- From \varnothing 40 to \varnothing 80 z=2

| D | B | D | B |
|----|----|----|----|
| 20 | 25 | 60 | 30 |
| 30 | 25 | 60 | 40 |
| 30 | 30 | 60 | 50 |
| 40 | 20 | 70 | 30 |
| 40 | 30 | 70 | 40 |
| 40 | 40 | 70 | 50 |
| 50 | 30 | 80 | 30 |
| 50 | 40 | 80 | 40 |
| 50 | 50 | 80 | 50 |

SPARE KNIVES QUOTED ON REQUEST

Price depends on the diameter and length of the cutters.
For a specific quote a detailed drawing or a sample are required.

HW INSERT COMPRESSION ROUTER CUTTERS

ART. W165

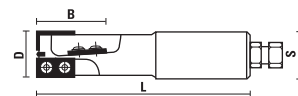

This item is sold complete with a torx key

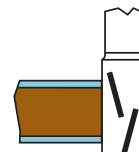

- Axial angle positive and negative compression bits
- HW plunging tip

| Item | D | B | L | S | Z |
|------------|----|----|-----|----------------|-------|
| W165.200.R | 20 | 30 | 110 | 25x55 | 2+2+1 |
| W165.201.R | 20 | 50 | 125 | 25x55 | 2+2+1 |
| W165.202.R | 20 | 30 | 134 | MK2 - M 30x1,5 | 2+2+1 |
| W165.203.R | 20 | 50 | 157 | MK2 - M 30x1,5 | 2+2+1 |



Z051.308.R



Z052.302.N



Z055.516.N (B=30)
Z055.528.N (B=50)

HW INSERT COMPRESSION ROUTER CUTTERS

ART. W165

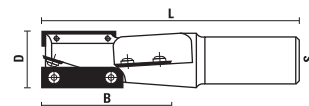

This item is sold complete with a torx key

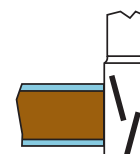

- Axial angle positive and negative compression bits
- With spare knife for plunging

| Item | D | B | L | S | Z |
|------------|----|----|-----|-------|-------|
| W165.300.R | 30 | 75 | 145 | 25x55 | 2+2+1 |



Z051.210.R



Z052.201.N



Z055.341.N



Z055.000.N

HW INSERT ROUTER BITS FOR CABINET DOORS Z=2

ART. W160

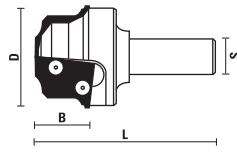

This item is sold complete with a torx key

PROFILE A1

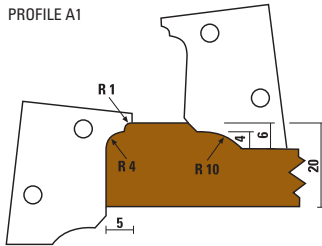

PROFILE A2

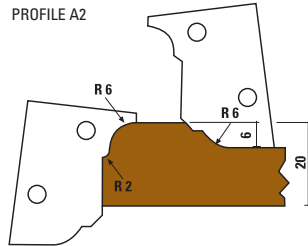

PROFILE A3

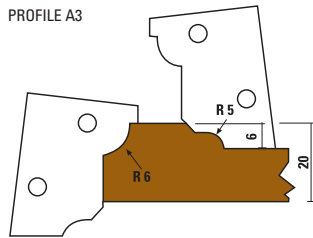

PROFILE A4

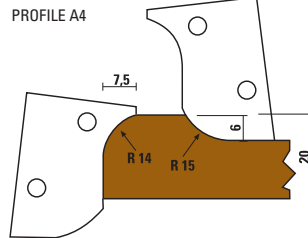

PROFILE A5

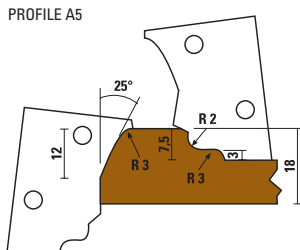

PROFILE A6

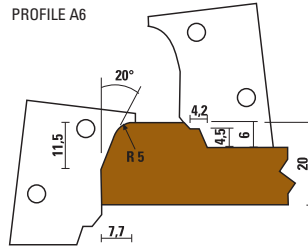

- With reversible knives
- For producing either the external or internal moulding

| Item | D | B | L | S | Profile |
|------------|----|----|-----|-------|---------|
| W160.601.R | 50 | 40 | 115 | 20x50 | A1 |
| W160.602.R | 50 | 40 | 115 | 20x50 | A2 |
| W160.603.R | 50 | 40 | 115 | 20x50 | A3 |
| W160.604.R | 50 | 40 | 115 | 20x50 | A4 |
| W160.605.R | 50 | 40 | 115 | 20x50 | A5 |
| W160.606.R | 50 | 40 | 115 | 20x50 | A6 |

Spare parts

Tool body without knives

W160.600.R



Z051.010.R



Z055.661.R (A1)
Z055.662.R (A2)
Z055.663.R (A3)
Z055.664.R (A4)
Z055.665.R (A5)
Z055.666.R (A6)



Z052.201.N

HW INSERT ROUTER BITS FOR CABINET DOORS Z=2

ART. W161

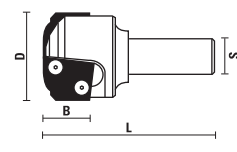

This item is sold complete with a torx key

PROFILE B1

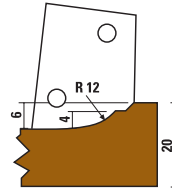

PROFILE B2

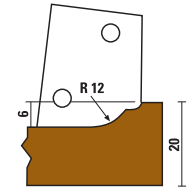

PROFILE B3

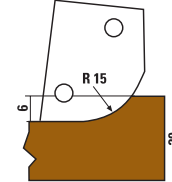

PROFILE B4

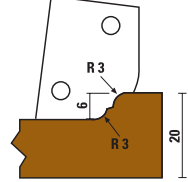

PROFILE B5

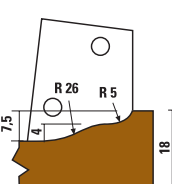

PROFILE B6

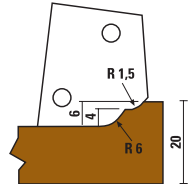

- With reversible knives
- For producing the internal moulding

| Item | D | B | L | S | Profile |
|------------|----|----|----|-------|---------|
| W161.501.R | 52 | 25 | 90 | 20x50 | B1 |
| W161.502.R | 52 | 25 | 90 | 20x50 | B2 |
| W161.503.R | 52 | 25 | 90 | 20x50 | B3 |
| W161.504.R | 52 | 25 | 90 | 20x50 | B4 |
| W161.505.R | 52 | 25 | 90 | 20x50 | B5 |
| W161.506.R | 52 | 25 | 90 | 20x50 | B6 |

Spare parts

Tool body without knives

W161.500.R



Z051.010.R



Z055.651.R (B1)
Z055.652.R (B2)
Z055.653.R (B3)
Z055.654.R (B4)
Z055.655.R (B5)
Z055.656.R (B6)



Z052.201.N

HW INSERT ROUTER BITS FOR DECORATION AND ENGRAVING Z=1

ART. W162

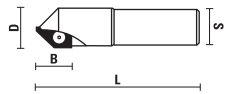

This item is sold complete with a torx key

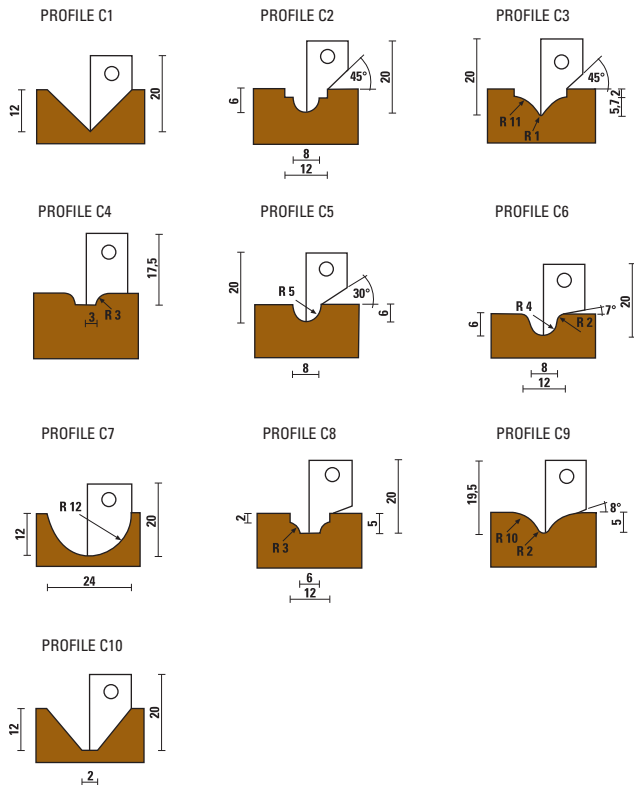

With reversible knives

| Item | D | B | L | S | Profile |
|------------|----|----|----|-------|---------|
| W162.241.R | 24 | 20 | 95 | 20x50 | C1 |
| W162.242.R | 24 | 20 | 95 | 20x50 | C2 |
| W162.243.R | 24 | 20 | 95 | 20x50 | C3 |
| W162.244.R | 24 | 20 | 95 | 20x50 | C4 |
| W162.245.R | 24 | 20 | 95 | 20x50 | C5 |
| W162.246.R | 24 | 20 | 95 | 20x50 | C6 |
| W162.247.R | 24 | 20 | 95 | 20x50 | C7 |
| W162.248.R | 24 | 20 | 95 | 20x50 | C8 |
| W162.249.R | 24 | 20 | 95 | 20x50 | C9 |
| W162.250.R | 24 | 20 | 95 | 20x50 | C10 |

Spare parts

Tool body without knives

W162.240.R



Z051.010.R



Z055.641.N (C1)
Z055.642.N (C2)
Z055.643.N (C3)
Z055.644.N (C4)
Z055.645.N (C5)
Z055.646.N (C6)
Z055.647.N (C7)
Z055.648.N (C8)
Z055.649.N (C9)
Z055.650.N (C10)



Z052.201.N

COMPLETE SET FOR DECORATING AND ENGRAVING

ART. XW162

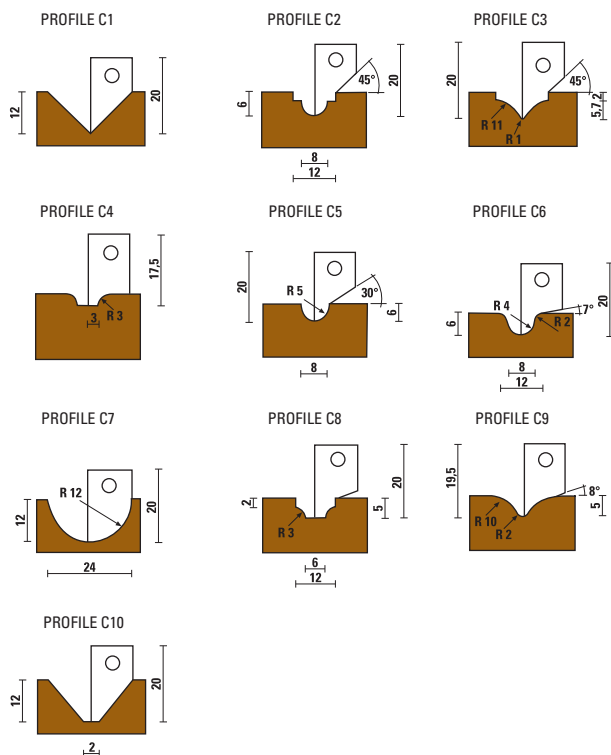

- Set includes a tool body with nr. 10 profiled knives
- With reversible knives
- Z=1
- In plastic case

Item

XW162.001.N

complete with:

W162.250.R

| Spare knife | Dimension | Profile |
|-------------|-----------|---------|
| Z055.641.R | 45° | C1 |
| Z055.642.R | R4/45° | C2 |
| Z055.643.R | R1/R11 | C3 |
| Z055.644.R | R3 | C4 |
| Z055.645.R | R8/30° | C5 |
| Z055.646.R | R4/R2 | C6 |
| Z055.647.R | R12 | C7 |
| Z055.648.R | R3/2 | C8 |
| Z055.649.R | R2/R10 | C9 |
| Z055.650.R | 45°/2 | C10 |



Z051.010.R



Z052.201.N

COMPLETE CUTTERS SET FOR CABINET DOORS

ART. XW160



Set including 3 cutters with HW knives and torx key

PROFILE EXAMPLES

Item

XW160.001.N including: W160.601.R + W161.501.R + W162.250.R + Z052.201.N

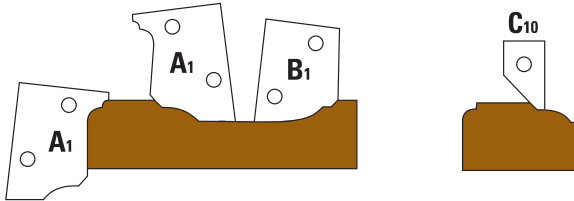

Item

XW160.002.N including: W160.602.R + W161.502.R + W162.250.R + Z052.201.N

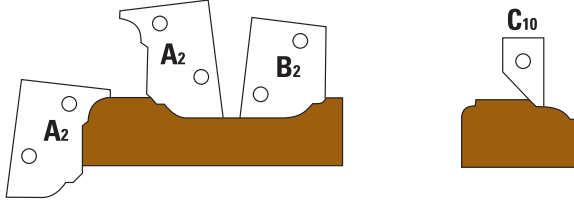

Item

XW160.003.N including: W160.603.R + W161.503.R + W162.250.R + Z052.201.N

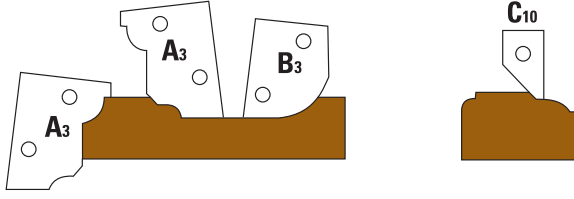

Item

XW160.004.N including: W160.605.R + W161.505.R + W162.250.R + Z052.201.N

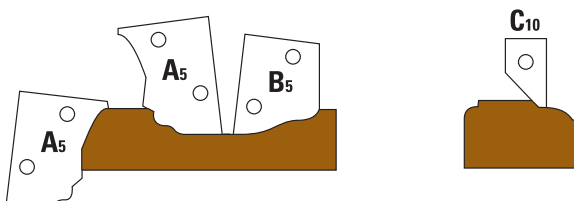

Item

XW160.005.N including: W160.606.R + W161.506.R + W162.250.R + Z052.201.N

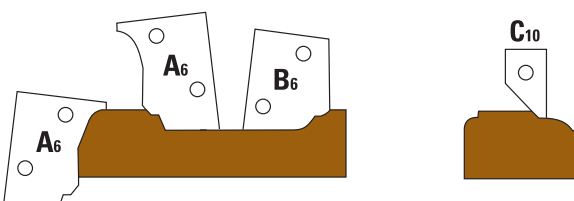

PROFILE EXAMPLE

Item **W160**

Execution nr. 1 and 2

Working with the same cutter you can produce either the external (nr. 1 - routing) or internal (nr. 2 - profiling) profile

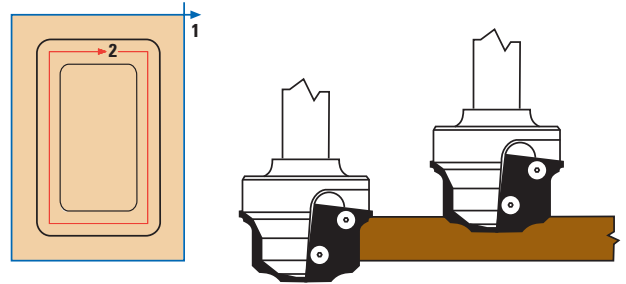

Item **W161**

Execution nr. 3

Profiling the internal side

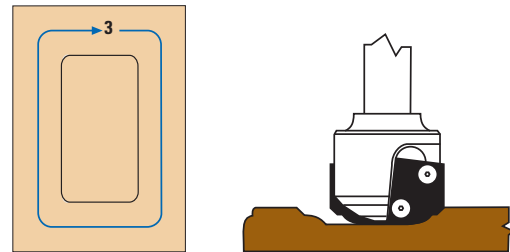

Item **W162**

Execution nr. 4 and 5

This cutter is used to work the decoration on top and can be used with different profiled knives

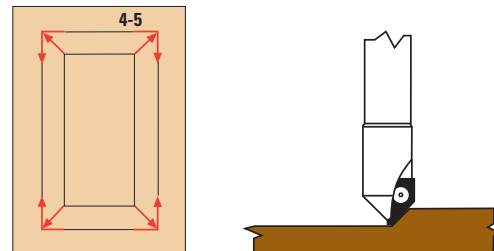

HW INSERT VARI-ANGLE ROUTER CUTTERS 1° Z=2

ART. W168

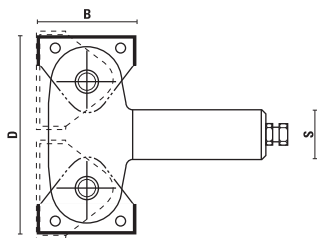

This item is sold complete with a hex key

- Adjustable 0° - 45° top
- Adjustable 0° - 90° bottom
- Adjustable by 1 degree

| Item | D | B | Z | S |
|------------|----|----|---|-------|
| W168.085.R | 85 | 40 | 2 | 25x55 |
| W168.185.R | 85 | 40 | 2 | 20x55 |

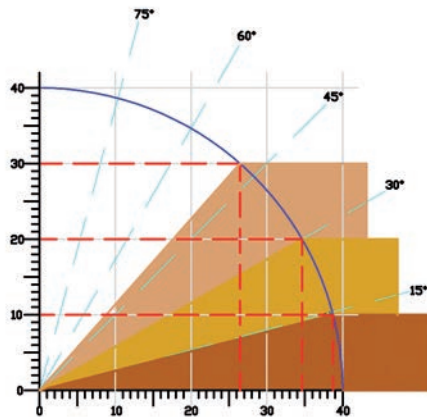
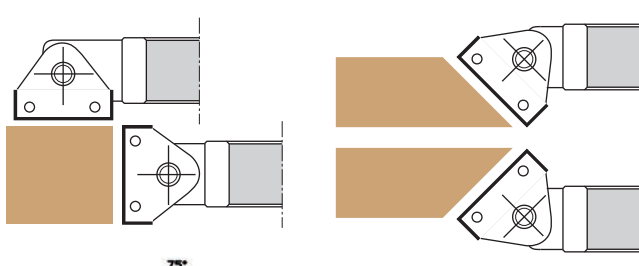
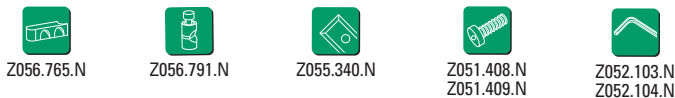

HW INSERT ROUTER BITS FOR ENGRAVINGS Z=1

ART. W170

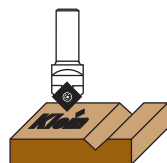
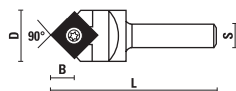

This item is sold complete with a torx key

Used on handportable machines, CNC routers and machining centres

| Item | D | B | L | Z | S |
|------------|----|-----|----|---|----|
| W170.170.R | 17 | 8,4 | 60 | 1 | 12 |



HW INSERT ROUTER BITS FOR ENGRAVINGS Z=1

ART. W170

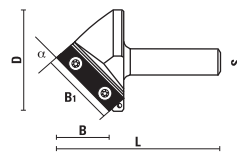

This item is sold complete with a torx key

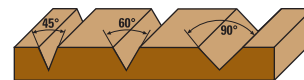

Used on handportable machines, CNC routers and machining centres

| Item | D | α | B | B ₁ | L | S |
|------------|----|----------|----|----------------|----|----|
| W170.210.R | 21 | 45° | 25 | 27 | 61 | 12 |
| W170.260.R | 26 | 60° | 23 | 27 | 61 | 12 |
| W170.380.R | 38 | 90° | 19 | 27 | 76 | 12 |



HW INSERT V-GROOVE ROUTER BITS Z=1

ART. W171

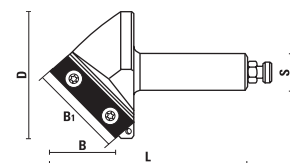

This item is sold complete with a torx key

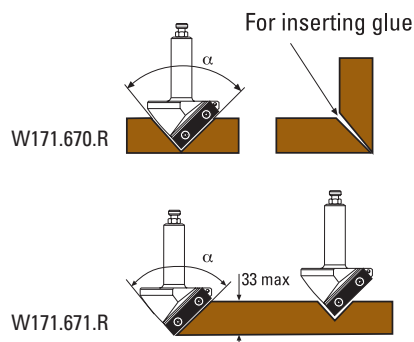

Used on CNC routers and machining centres

| Item | D | α | B | B ₁ | L | S |
|------------|----|----------|----|----------------|----|----|
| W171.670.R | 67 | 91° | 33 | 46,5 | 97 | 20 |
| W171.671.R | 67 | 90° | 33 | 46,5 | 97 | 20 |



HW INSERT ROUTER BITS FOR LOCKS Z=2

ART. W172 - W173

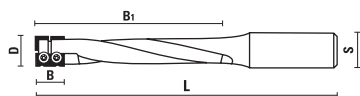

This item is sold complete with a torx key

Used on CNC routers and machining centres

| Item | D | B | B ₁ | L | S |
|-------------|----|----|----------------|-----|-------|
| W172.160.R | 16 | 16 | 115 | 170 | 16x55 |
| W172.161.R | 16 | 23 | 105 | 150 | 16x45 |
| W172.180.R* | 18 | 16 | 115 | 170 | 16x55 |
| W173.160.R* | 16 | 16 | 115 | 170 | 20x55 |
| W173.161.R | 16 | 23 | 115 | 170 | 20x55 |
| W173.180.R* | 18 | 16 | 115 | 170 | 20x55 |

*Selling out



Z051.308.R



Z052.302.N



Z055.501.N
Z055.502.N
(16x7x1,5)



Z055.503.N
Z055.504.N
(23x7x1,5)

HW INSERT ROUTER BITS FOR LOCKS Z=2 HEAVY METAL TOOL BODY

ART. W172

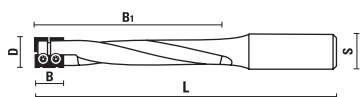

This item is sold complete with a torx key

- Used on CNC routers and machining centres
- Heavy metal tool body
- Low-vibration machining
- Reduced risk of tool breakage

| Item | D | B | B ₁ | L | S |
|--------------|----|----|----------------|-----|-------|
| W172.160.RAP | 16 | 16 | 115 | 170 | 16x55 |



Z051.308.R



Z052.302.R



Z055.501.N
Z055.502.N

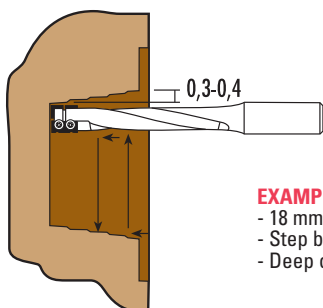

EXAMPLE OF USE:

- 18 mm: n. 12.000-20.000 min⁻¹
- Step by step cutting 0,3-0,4 mm
- Deep cutting with excellent chip flow

HW INSERT ROUTER BITS Z=3

ART. W174 - W175

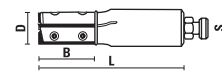

This item is sold complete with a hex key

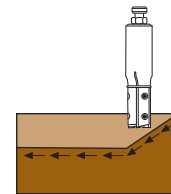

- Extremely silent
- Improved balancing compared with traditional system
- Used on CNC routers and machining centres
- **- NO CUTTING EDGE FOR BORING**

| Item | Rotat. | D | B | L | S |
|------------|--------|----|----|-----|----|
| W174.180.R | Rh | 18 | 50 | 102 | 20 |



Z051.404.R



Z052.007.N



Z055.500.R
Z055.500.L

HW INSERT ROUTER BITS FOR PLANING AND RABBETING Z=2+2

ART. W176 - W177

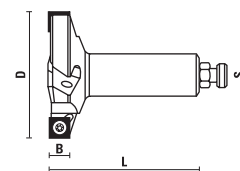

This item is sold complete with a torx key

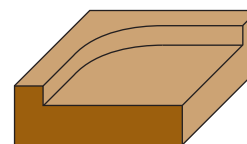

- Ideal for removing material over large surface areas
- Used on CNC routers and machining centres

| Item | D | B | L | S |
|------------|----|----|----|----|
| W176.800.R | 80 | 12 | 90 | 20 |

| Item | D | B | L | S |
|------------|----|----|----|----|
| W177.800.R | 80 | 12 | 90 | 25 |



Z051.402.R



Z051.403.R



Z052.201.N



Z055.001.N
knife



Z055.007.N
spur

HW INSERT ROUTER CUTTERS, ROUGHING Z=4

ART. W178 - W179

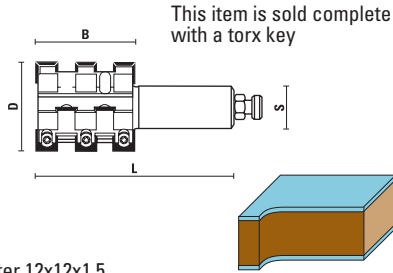

- Multi cutting flutes router cutter 12x12x1,5
- Used on CNC routers and machining centres

| Item | D | B | L | S | Z |
|------------------------|----|----|-----|----|---|
| W178.500.R Selling out | 50 | 56 | 113 | 20 | 4 |
| W178.501.R Selling out | 50 | 78 | 135 | 20 | 4 |

| | | | | | |
|------------|----|----|-----|----|---|
| W179.500.R | 50 | 56 | 113 | 25 | 4 |
| W179.501.R | 50 | 78 | 135 | 25 | 4 |



HW INSERT FINGER JOINT ROUTER CUTTERS Z=2

ART. W180 - W181

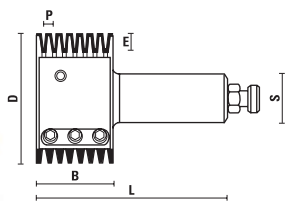

This item is sold complete with a hex key

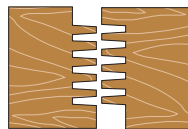

Used on CNC routers and machining centres

| Item | D | B | L | P | E | S |
|-------------|----|----|-----|-----|---|----|
| W181.700.R* | 70 | 40 | 100 | 5,4 | 8 | 25 |

*Selling out



HW INSERT ADJUSTABLE ROUTER CUTTERS FOR GROOVING

ART. W182 - W183

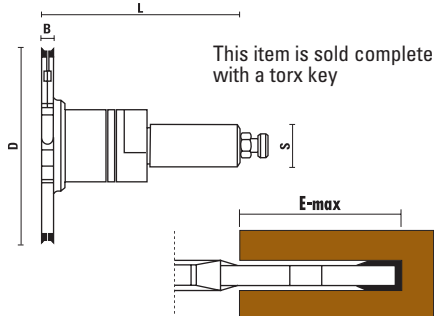

- Suitable for producing different thickness grooves
- Thickness adjustable in 0,1 mm steps by means of spacers
- Used on CNC routers and machining centres
- Can be produced with HSK or ISO30 shank on request

| Item | D | B | L | S | E-max |
|------------|-----|--------|-----|----|-------|
| W182.120.R | 120 | 4±15,5 | 140 | 20 | 33 |

| | | | | | |
|------------|-----|--------|-----|----|----|
| W183.120.R | 120 | 4±15,5 | 140 | 25 | 33 |
|------------|-----|--------|-----|----|----|

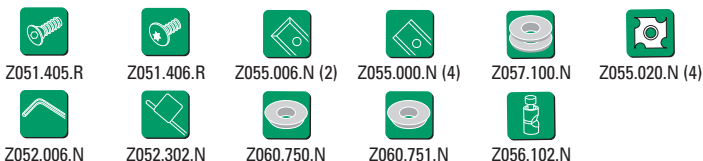

HW INSERT ROUTER BITS FOR PLANING AND RABBETING

ART. W190 - WE190 - WG190

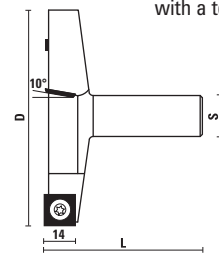

This item is sold complete with a torx key

10° shear angle

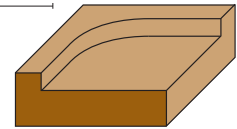

- Used for **surfacing MDF and particle board** and making deep rabbet
- **10° shear angle** for better performance
- Suitable for processing ever kind of wood
- To be used on machining centres and CNC routers
- Right-hand rotation
- For greater performance PCD knives can be mounted (see page 11.10)

| Item | D | B | L | Z | S |
|-----------------------|-----------|----|--------|---|-----------------|
| W190.100.R NEW | 100 | 14 | 80 | 3 | ∅20x55 |
| W190.101.R NEW | 101,6(4") | 14 | 76(3") | 3 | ∅19,05(3/4")x55 |



| | | | | | |
|------------------------|--------------|----|------------|---|----------------|
| WE190.800.R NEW | 80 | 14 | 76 | 3 | ∅12x50 |
| WG190.635.R NEW | 63,5(2-1/2") | 14 | 70(2-3/4") | 2 | ∅12,7(1/2")x45 |



HW INSERT ROUTER BITS FOR PLASTIC MATERIAL

ART. W190.RU - WE190.RU - WG190.RU

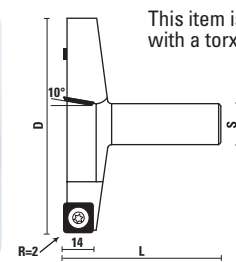

This item is sold complete with a torx key

10° shear angle

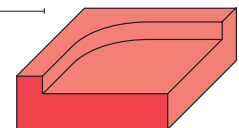
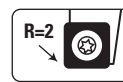

- Used for **surfacing plastic board material** and making deep rabbet (also known as Flycutters - Spoilboard cutters)
- Special insert knives with radius (R=2) for smoother cuts and no risk of marks and scratch.
- **10° shear angle** for better performance
- To be used on machining centres and CNC routers
- Right-hand rotation

| Item | D | B | L | Z | S |
|------------------------|-----------|----|--------|---|-----------------|
| W190.100.RU NEW | 100 | 14 | 80 | 3 | ∅20x55 |
| W190.101.RU NEW | 101,6(4") | 14 | 76(3") | 3 | ∅19,05(3/4")x55 |



| | | | | | |
|-------------------------|--------------|----|------------|---|----------------|
| WE190.800.RU NEW | 80 | 14 | 76 | 3 | ∅12x50 |
| WG190.635.RU NEW | 63,5(2-1/2") | 14 | 70(2-3/4") | 2 | ∅12,7(1/2")x45 |



INSERT ROUTER BITS FOR PORTABLE ROUTERS

Always looking for innovative products and most useful solutions, **SISTEMI** has developed a new line of router bits **Klein** with interchangeable carbide knives, which have a higher hardness than the tips used in traditional brazed router bits.

The main advantages granted by the use of HM reversible knives and the possibility of their easy replacement are:

- **Longer tool life** ⇒ the knives are getting less worn out and in case of damage they can be easily replaced;
- **Better finish quality** ⇒ also working abrasive materials, the cutting edge can be maintained always sharp;
- **Higher measures precision** ⇒ the dimensions of the tools are not changing because there is no resharpening;
- **Better Quality/Price ratio** ⇒ higher production efficiency, less costs and better performances.

HW INSERT FLUSH TRIMMING BITS Z=1

ART. WC101

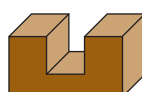
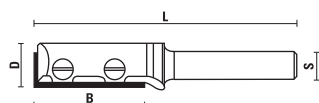

With reversible knives

| S ∅ 8 | D | B | L |
|-------------|------------|------|----|
| WC101.120.R | 12 | 29,5 | 66 |
| | | | |
| Z055.330.N | Z051.501.R | | |

HW INSERT V-GROOVING BITS Z=1

ART. WC109

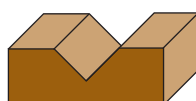
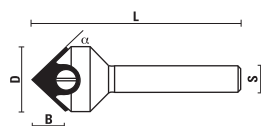

With reversible knives

| S ∅ 8 | D | B | α | L |
|-------------|------------|-----|-----|----|
| WC109.176.R | 17,6 | 8,5 | 45° | 53 |
| | | | | |
| Z055.001.N | Z051.501.R | | | |

HW INSERT CORE BOX BITS WITH UPPER BALL BEARING Z=1

ART. WC111

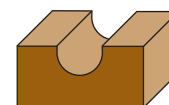
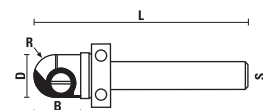

With reversible knives

| S ∅ 8 | D | B | R | L |
|-------------|------------|------------|---|----|
| WC111.127.R | 12,7 | 13 | 6 | 59 |
| | | | | |
| Z050.018.N | Z055.550.N | Z051.501.R | | |

HW INSERT FLUSH TRIMMING BITS WITH BALL BEARING

ART. WC120

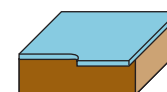
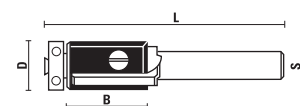

With reversible knives

| S ∅ 8 | D | B | L | Z |
|-------------|------------|--------------------------------------|--------------------------------|---|
| WC120.127.R | 12,7 | 20 | 62 | 2 |
| | | | | |
| Z050.003.N | Z055.551.N | Z051.503.N Screw for ball bearing | Z051.501.R Screw for knives | |

HW INSERT FLUSH TRIMMING BITS WITH BALL BEARING Z=2

ART. WC121

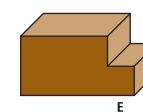
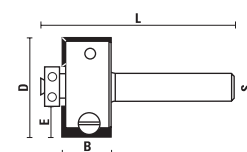

With reversible knives

| S ∅ 8 | D | B | E | L |
|-------------|------------|--------------------------------------|--------------------------------|----|
| WC121.286.R | 28,6 | 13,2 | 7,95 | 48 |
| | | | | |
| Z050.002.N | Z055.552.N | Z051.503.N Screw for ball bearing | Z051.501.R Screw for knives | |

HW INSERT FLUSH TRIMMING BITS WITH BALL BEARING Z=2

ART. WC122

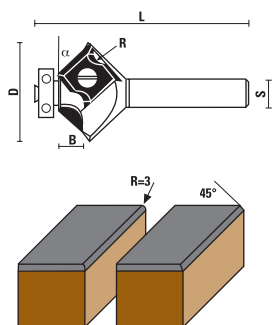

- With reversible knives
- The same knives can be used for both 45° and R= 3 bevel



| S Ø 8 | D | B | R | α | L |
|-------------|------------|--------------------------------------|--------------------------------|-----|----|
| WC122.273.R | 27,3 | 5,7 | 3 | 45° | 59 |
| Z050.003.N | Z055.553.N | Z051.503.N Screw for ball bearing | Z051.501.R Screw for knives | | |

HW INSERT COVER BITS WITH BALL BEARING Z=2

ART. WC125

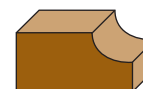
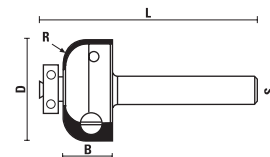

With reversible knives



| S Ø 8 | D | B | R | L |
|-------------|------------|--------------------------------------|--------------------------------|----|
| WC125.260.R | 26 | 12,7 | 6 | 55 |
| Z050.003.N | Z055.555.N | Z051.503.N Screw for ball bearing | Z051.501.R Screw for knives | |

HW INSERT CORNER ROUNDING BITS WITH BALL BEARING Z=2

ART. WC123

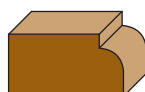
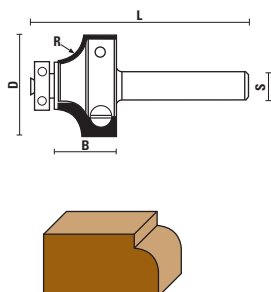

With reversible knives



| S Ø 8 | D | B | R | L |
|-------------|------------|--------------------------------------|--------------------------------|----|
| WC123.260.R | 26 | 15,7 | 6 | 55 |
| Z050.003.N | Z055.554.N | Z051.503.N Screw for ball bearing | Z051.501.R Screw for knives | |

HW INSERT OGEE BITS WITH BALL BEARING Z=2

ART. WC129

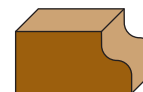
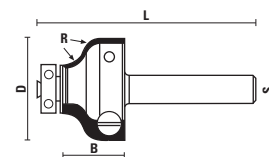

With reversible knives



| S Ø 8 | D | B | R | L |
|-------------|------------|--------------------------------------|--------------------------------|----|
| WC129.260.R | 26 | 15,7 | 4,5 | 55 |
| Z050.003.N | Z055.556.N | Z051.503.N Screw for ball bearing | Z051.501.R Screw for knives | |

6 PIECE INSERT ROUTER BITS "SET"

ART. XWC



- Set including the 6 most popular HW router bits in S=8 in a robust and practical wooden box.
- Ideal to have always on hand the right bit for straight cuts, trimming and engraving.
- Router bit with reversible knives

See page 1.35

| Item |
|---------------------------|
| XWC.001.R |
| 6-pcs router bit set: |
| WC101.120.R - WC109.176.R |
| WC111.127.R - WC120.127.R |
| WC121.286.R - WC122.273.R |

6 PIECE INSERT ROUTER BITS "SET"

ART. XWC



- Set including the 6 most popular HW router bits in S=8 in a robust and practical wooden box.
- Ideal to have always on hand the right bit for trimming and profiling.
- Router bit with reversible knives

See page 1.35

| Item |
|---------------------------|
| XWC.002.R |
| 6-pcs router bit set: |
| WC120.127.R - WC121.286.R |
| WC122.273.R - WC123.260.R |
| WC125.260.R - WC129.260.R |

HW INSERT ROUTER BITS Z=2+1

ART. WE100

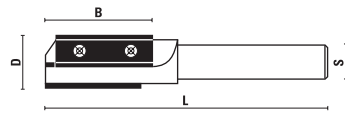

This item is sold complete with a torx key

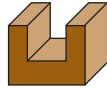

With HW boring tip

| S Ø 12 | D | B | L |
|-------------|----|----|-----|
| WE100.160.R | 16 | 50 | 110 |
| WE100.180.R | 18 | 50 | 110 |
| WE100.200.R | 20 | 50 | 110 |
| WE100.220.R | 22 | 50 | 110 |



Z051.010.R



Z052.201.N



Z055.340.N

HW INSERT ROUTER BITS Z=2 WITH STRAIGHT CUTTERS

ART. WE101

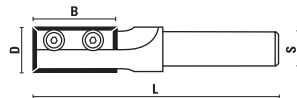

This item is sold complete with a torx key

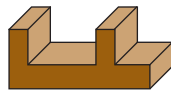

S=1/2" on request art. WG

| S Ø 12 | D | B | L |
|-------------|----|------|----|
| WE101.120.R | 12 | 29,5 | 81 |
| WE101.140.R | 14 | 29,5 | 86 |
| WE101.160.R | 16 | 29,5 | 88 |
| WE101.180.R | 18 | 29,5 | 86 |
| WE101.200.R | 20 | 29,5 | 86 |
| WE101.220.R | 22 | 29,5 | 88 |



Z051.400.R



Z052.201.N



Z055.329.N

HW INSERT BALL SLOT ROUTER BITS Z=2

ART. WE112

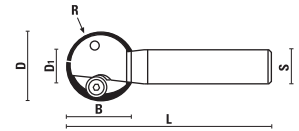

This item is sold complete with a torx key

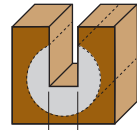
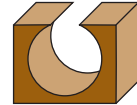

min 11

These tools can produce grooves for sliding panels or electrical wires, after a first groove wich allows the tool shank moving

S=1/2" on request art. WG

| S Ø 12 | D | D1 | R | B | L |
|-------------|------|----|------|----|----|
| WE112.127.R | 12,7 | 10 | 6,4 | 10 | 67 |
| WE112.160.R | 16 | 13 | 8 | 14 | 70 |
| WE112.190.R | 19 | 15 | 9,5 | 17 | 67 |
| WE112.254.R | 25,4 | 17 | 12,7 | 24 | 73 |



Z051.308.R
(D da 12,7 a 19)



Z051.400.R
(D=25,4)



Z052.201.N (Z051.308)
Z052.302.N (Z051.400)



Z055.572.N
Z055.573.N



Z055.574.N
Z055.575.N

HW INSERT REBATE BITS Z=2

ART. WE150

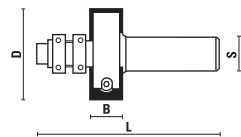

This item is sold complete with a torx key

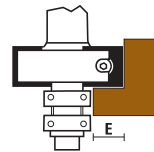

S=1/2" on request art. WG

| S Ø 12 | D | B | L | E |
|-------------|----|----|----|----|
| WE150.380.R | 38 | 12 | 66 | 12 |



Z050.007.N



Z051.400.R



Z052.201.N



Z055.001.N



Z054.410.N



Z054.002.N

HW INSERT RABBETING BITS Z=2

ART. WE150

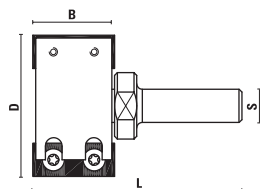

- Suitable for working with FESTOOL® CMS-OF 1010/ BASIS 5A/BASIS 6
- To be used with FESTOOL® Compact Modular System (CMS)
- This item is sold complete with a torx key

| Item | D | B | L | Z | S |
|------------------------|----|----|----|---|----|
| WE150.500.R NEW | 50 | 30 | 70 | 2 | 12 |

SPARE PARTS

Rabbeting head

| | | | |
|------------------------|--------|----------|-----|
| WE150.505.R NEW | Ø50x30 | Foro Ø12 | Z=2 |
|------------------------|--------|----------|-----|

Cutter arbor

| | |
|-----------------------|-----------|
| E117.130.N NEW | S= Ø12x36 |
|-----------------------|-----------|



Z051.010.R



Z052.201.N



Z055.110.N

ASSEMBLY

WE150.505.R
Rabbeting head



+

E117.130.R
Cutter arbor



=

WE150.500.R



visit our website
www.sistemiklein.com

CONTACT US
(+39) 0721 28950
info@sistemiklein.com



HW INSERT REBATE BITS Z=2

ART. WE150



This item is sold complete with a torx key

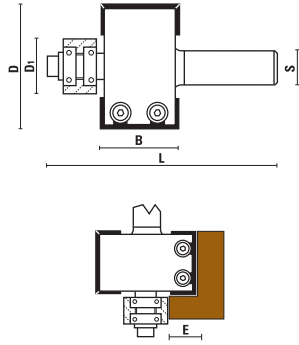

- This item is sold complete with a guide collar D=19 mm (our item Z050.903.N) to obtain rabbet width of E=16 mm.
- S=1/2" on request art. WG

| S Ø 12 | D | B | L | E |
|-------------|------------|------------|------------|------------|
| WE150.510.R | 51 | 29,5 | 84 | 16 |
| | | | | |
| Z050.007.N | Z051.400.R | Z052.201.N | Z055.329.N | Z054.410.N |
| Z054.002.N | | | | |

| BEARING RINGS | D1 | E |
|---------------|------------------------------------|-------|
| Z050.901.N | 14,31 | 18,25 |
| Z050.902.N | 16 | 17,5 |
| Z050.903.N | 19 | 16 |
| Z050.904.N | 20,6 | 15,2 |
| Z050.905.N | 22,2 | 14,3 |
| Z050.906.N | 25,4 | 12,7 |
| Z050.907.N | 27 | 12 |
| Z050.908.N | 28,6 | 11,1 |
| Z050.909.N | 31,8 | 9,5 |
| Z050.910.N | 32,5 | 9,25 |
| Z050.911.N | 35 | 8 |
| Z050.912.N | 38 | 6,4 |
| Z050.913.N | 39 | 6 |
| Z050.914.N | 41,3 | 4,8 |
| Z050.915.N | 44,4 | 3,2 |
| Z050.916.N | 47,6 | 1,6 |
| Z050.999.N | set complete with 16 bearing rings | |

HW INSERT PROFILE RAISED PANEL ROUTER CUTTERS Z=2

ART. WE178



This item is sold complete with a torx key

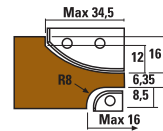
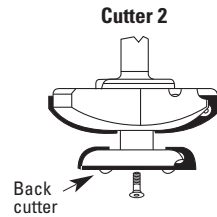
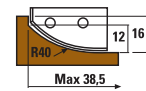
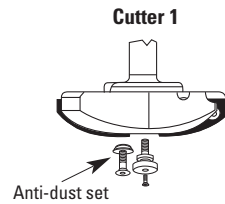
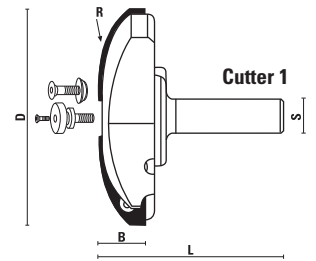

S=1/2" on request art. WG

| S Ø 12 | D | R | B | L |
|---|------------|------------|------------|------------|
| WE178.860.R - Cutter 1 | 86 | 40 | 21,2 | 72 |
| WE178.870.R - Cutter 2 (Complete with back cutter) | 86 | 40 | 21,2 | 72 |
| | | | | |
| Z051.050.N | Z051.400.R | Z051.050.R | Z052.201.N | Z055.560.N |
| WE178.999.R - Back cutter Ø=54x26,7 | | | | |
| | | | | |
| Z051.308.R | Z052.302.N | Z055.569.N | | |

**HW INSERT PROFILE RAISED PANEL
ROUTER CUTTERS Z=2**

ART. WE178

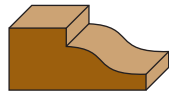
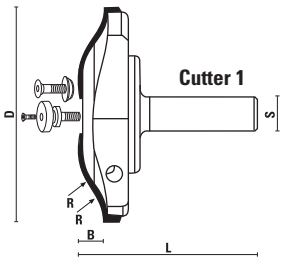

This item is sold complete with a torx key

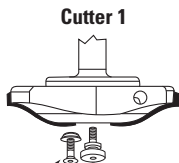

Anti-dust set

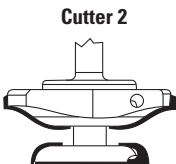
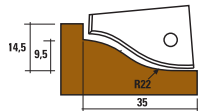

Back cutter

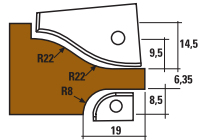

S=1/2" on request art. WG

| S Ø 12 | D | R | B | L |
|-------------------------------|----|----|----|----|
| WE178.862.R - Cutter 1 | 86 | 22 | 19 | 69 |
| WE178.872.R - Cutter 2 | 86 | 22 | 19 | 69 |

(Complete with back cutter)



WE178.999.R - **Back cutter** Ø=54x26,7



**HW INSERT PROFILE RAISED PANEL
ROUTER CUTTERS Z=2**

ART. WE178

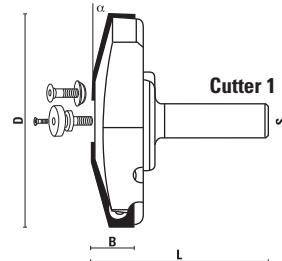

This item is sold complete with a torx key

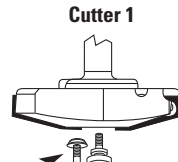
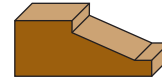

Anti-dust set

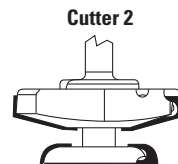
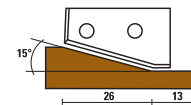

Back cutter

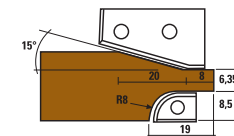

S=1/2" on request art. WG

| S Ø 12 | D | α | B | L |
|--------------------------------|----|-----|----|----|
| WE178.861.R* - Cutter 1 | 86 | 15° | 20 | 71 |
| WE178.871.R* - Cutter 2 | 86 | 15° | 20 | 71 |

(Complete with back cutter)

* Selling out

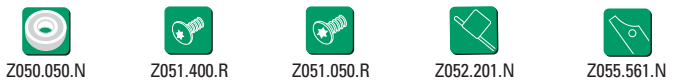

WE178.999.R - **Back cutter** Ø=54x26,7



HW INTERCHANGEABLE INSERT ROUTER BITS "NOVA SYSTEM" Z=2

ART. W200 - W201

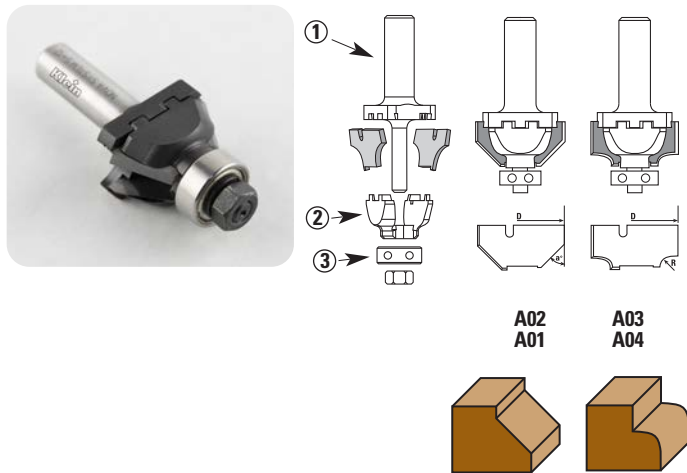

- Replaceable carbide tips
- Patent pending # 129720
- These tools have been checked by the BIA



| S Ø 8 | S Ø 12 | D | α | R |
|--------------------------|------------|------|----------|-----|
| W200.350.C | W200.350.E | 35 | 30° | |
| W200.A01 - Spare inserts | | Pair | | |
| W200.380.C | W200.380.E | 38 | 45° | |
| W200.A02 - Spare inserts | | Pair | | |
| W201.350.C | W201.350.E | 35 | | 3,2 |
| W201.A03 - Spare inserts | | Pair | | |
| W201.351.C | W201.351.E | 35 | | 4,8 |
| W201.A04 - Spare inserts | | Pair | | |

SPARE PARTS

1) Arbor

W200.000.C W200.000.E

2) Safety shield

W201.001.N

3) Ball bearing

Z050.005.N - $\varnothing 19/\varnothing 6,4 \times 7,1$ mm

HW INTERCHANGEABLE INSERT ROUTER BITS "NOVA SYSTEM" Z=2

ART. W202 - W203 - W204 - W205

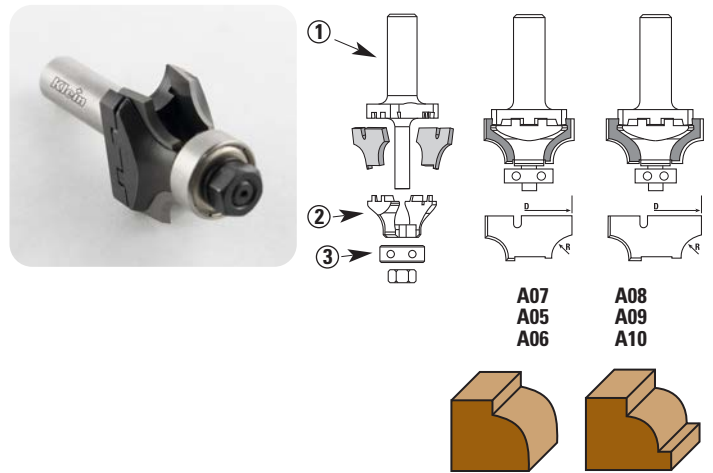

- Replaceable carbide tips
- Patent pending # 129720
- These tools have been checked by the BIA



| S Ø 8 | S Ø 12 | D | R |
|--------------------------|------------|------|-----|
| W202.350.C | W202.350.E | 35 | 6,4 |
| W202.A05 - Spare inserts | | Pair | |
| W202.351.C | W202.351.E | 35 | 8 |
| W202.A06 - Spare inserts | | Pair | |
| W203.380.C | W203.380.E | 38 | 9,5 |
| W203.A07 - Spare inserts | | Pair | |
| W204.350.C | W204.350.E | 35 | 4,8 |
| W204.A08 - Spare inserts | | Pair | |
| W204.351.C | W204.351.E | 35 | 6,4 |
| W204.A09 - Spare inserts | | Pair | |
| W205.380.C | W205.380.E | 38 | 8 |
| W205.A10 - Spare inserts | | Pair | |

SPARE PARTS

1) Arbor

W200.000.C W200.000.E

2) Safety shield

W201.002.N

3) Ball bearing

Z050.005.N - $\varnothing 19/\varnothing 6,4 \times 7,1$ mm

HW INTERCHANGEABLE INSERT ROUTER BITS "NOVA SYSTEM" Z=2

ART. W206 - W207 - W208

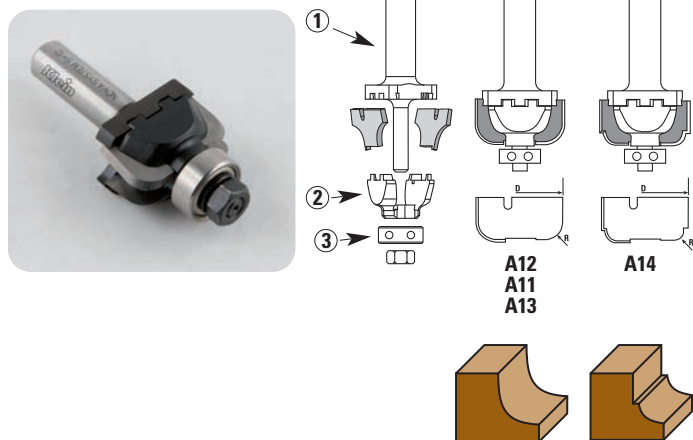

- Replaceable carbide tips
- Patent pending # 129720
- These tools have been checked by the BIA



| S Ø 8 | S Ø 12 | D | R |
|--------------------------|------------|------|-----|
| W206.350.C | W206.350.E | 35 | 6,4 |
| W206.A11 - Spare inserts | | Pair | |
| W206.351.C | W206.351.E | 35 | 8 |
| W206.A12 - Spare inserts | | Pair | |
| W207.380.C | W207.380.E | 38 | 9,5 |
| W207.A13 - Spare inserts | | Pair | |
| W208.350.C | W208.350.E | 35 | 4,8 |
| W208.A14 - Spare inserts | | Pair | |

SPARE PARTS

1) Arbor

W200.000.C W200.000.E

2) Safety shield

W201.001.N

3) Ball bearing

Z050.005.N - Ø19/Ø6,4 x 7,1 mm

HW INTERCHANGEABLE INSERT ROUTER BITS "NOVA SYSTEM" Z=2

ART. W209 - W210

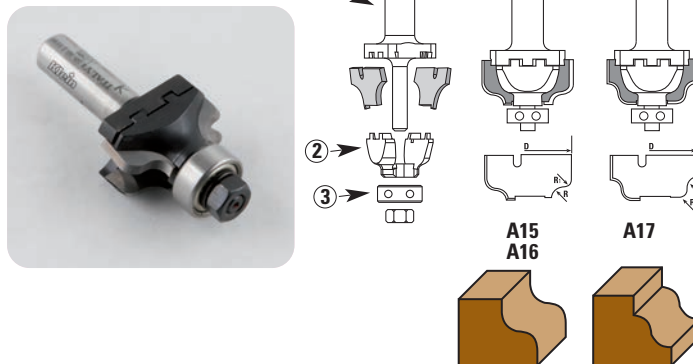

- Replaceable carbide tips
- Patent pending # 129720
- These tools have been checked by the BIA



| S Ø 8 | S Ø 12 | D | R | R1 |
|--------------------------|------------|------|---------|-----|
| W209.360.C | W209.360.E | 36 | 4,0 | 4,5 |
| W209.A15 - Spare inserts | | Pair | | |
| W209.380.C | W209.380.E | 38 | 4,0 | 4,5 |
| W209.A16 - Spare inserts | | Pair | | |
| W210.350.C | W210.350.E | 35 | 4,0/4,0 | |
| W210.A17 - Spare inserts | | Pair | | |

SPARE PARTS

1) Arbor

W200.000.C W200.000.E

2) Safety shield

W201.001.N

3) Ball bearing

Z050.005.N - Ø19/Ø6,4 x 7,1 mm

HW INTERCHANGEABLE INSERT ROUTER BITS "NOVA SYSTEM" Z=2

ART. W211 - W212 - W213

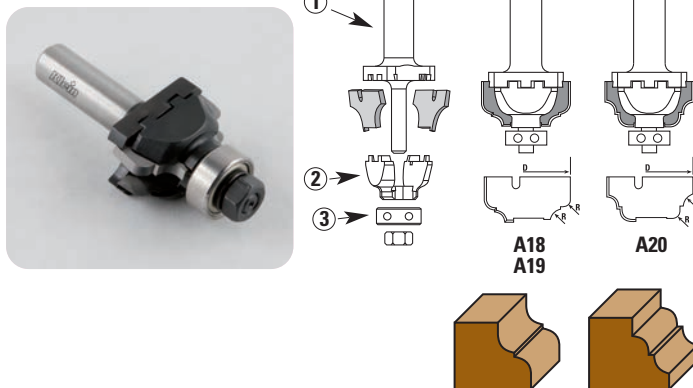

- Replaceable carbide tips
- Patent pending # 129720
- These tools have been checked by the BIA



| S Ø 8 | S Ø 12 | D | R |
|--------------------------|------------|------|---------|
| W211.350.C | W211.350.E | 35 | 4,0/4,0 |
| W211.A18 - Spare inserts | | Pair | |
| W212.380.C | W212.380.E | 38 | 4,0/4,0 |
| W212.A19 - Spare inserts | | Pair | |
| W213.380.C | W213.380.E | 38 | 4,0/4,0 |
| W213.A20 - Spare inserts | | Pair | |

SPARE PARTS

1) Arbor

W200.000.C W200.000.E

2) Safety shield

W201.001.N

3) Ball bearing

Z050.005.N - Ø19/Ø6,4 x 7,1 mm

HW INTERCHANGEABLE INSERT ROUTER BITS "NOVA SYSTEM" Z=2

ART. W214 - W215 - W216

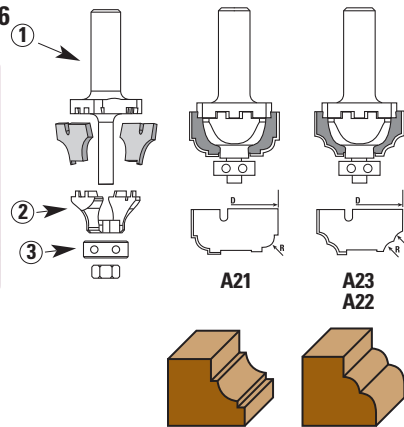

- Replaceable carbide tips
- Patent pending # 129720
- These tools have been checked by the BIA



| S Ø 8 | S Ø 12 | D | R |
|--------------------------|------------|------|---------|
| W214.350.C | W214.350.E | 35 | 4,8 |
| W214.A21 - Spare inserts | | Pair | |
| W215.350.C | W215.350.E | 35 | 4,0/4,0 |
| W215.A22 - Spare inserts | | Pair | |
| W216.380.C | W216.380.E | 38 | 4,0/4,0 |
| W216.A23 - Spare inserts | | Pair | |

SPARE PARTS

1) Arbor

W200.000.C W200.000.E

2) Safety shield

W201.001.N

3) Ball bearing

Z050.005.N - Ø19/Ø6,4 x 7,1 mm

HW INTERCHANGEABLE INSERT ROUTER BITS "NOVA SYSTEM" Z=2

ART. W250 - W251

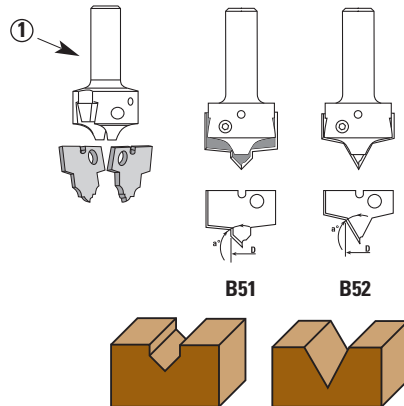

- Replaceable carbide tips
- Patent pending # 129720
- These tools have been checked by the BIA



| S Ø 8 | S Ø 12 | D | α |
|--------------------------|------------|------|-----|
| W250.095.C | W250.095.E | 9,5 | 45° |
| W250.B51 - Spare inserts | | Pair | |
| W251.127.C | W251.127.E | 12,7 | 30° |
| W251.B52 - Spare inserts | | Pair | |

SPARE PARTS

1) Safety shield

W250.000.C W250.000.E

HW INTERCHANGEABLE INSERT ROUTER BITS "NOVA SYSTEM" Z=2

ART. W252 - W253

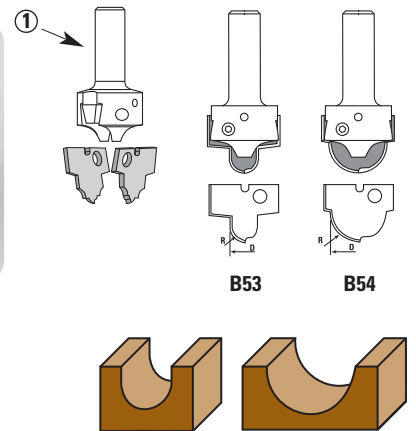

- Replaceable carbide tips
- Patent pending # 129720
- These tools have been checked by the BIA



| S Ø 8 | S Ø 12 | D | R |
|--------------------------|------------|------|------|
| W252.127.C | W252.127.E | 12,7 | 6,4 |
| W252.B53 - Spare inserts | | Pair | |
| W253.254.C | W253.254.E | 25,4 | 12,7 |
| W253.B54 - Spare inserts | | Pair | |

SPARE PARTS

1) Safety shield

W250.000.C W250.000.E

HW INTERCHANGEABLE INSERT ROUTER BITS "NOVA SYSTEM" Z=2

ART. W254

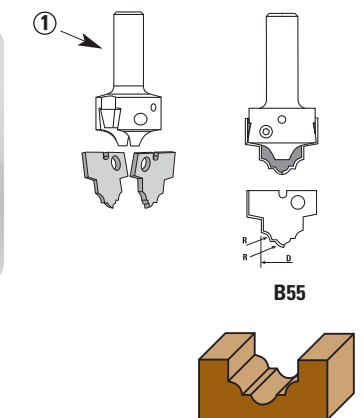

- Replaceable carbide tips
- Patent pending # 129720
- These tools have been checked by the BIA



| S Ø 8 | S Ø 12 | D | R |
|--------------------------|------------|------|---------|
| W254.190.C | W254.190.E | 19 | 4,0/4,0 |
| W254.B55 - Spare inserts | | Pair | |

SPARE PARTS

1) Safety shield

W250.000.C W250.000.E

HW INSERT ROUTER BITS "NOVA SYSTEM" Z=2

ART. W261 - W262

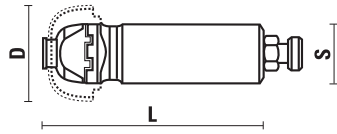

- Patented system
- HW standard knives
- Used on CNC router machines
- Additional knife profiles available on request

| Item | D | L | S |
|---------------------------|-------|------|----|
| W261.000.R only tool body | 35÷38 | 92,5 | 20 |
| W262.000.R only tool body | 35÷38 | 92,5 | 25 |

Add the requested knives

| | |
|----------|----------|
| W200.A01 | W206.A13 |
| W200.A02 | W208.A14 |
| W201.A03 | W209.A15 |
| W201.A04 | W209.A16 |
| W202.A05 | W210.A17 |
| W202.A06 | W211.A18 |
| W203.A07 | W212.A19 |
| W204.A08 | W213.A20 |
| W204.A09 | W214.A21 |
| W205.A10 | W215.A22 |
| W206.A11 | W216.A23 |
| W206.A12 | |

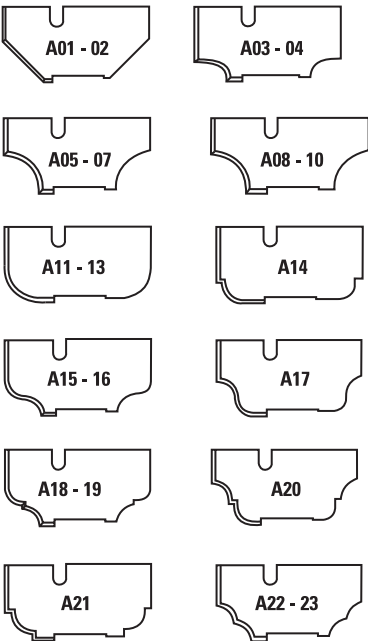

HW INSERT ROUTER BITS "NOVA SYSTEM" Z=2

ART. W260

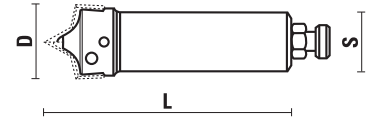

- Patented system
- HW standard knives
- Used on CNC router machines
- Additional knife profiles available on request

| Item | D | L | S |
|---------------------------|------|------|----|
| W260.000.R only tool body | 29,5 | 82,5 | 20 |

Add the requested knives

| |
|----------|
| W250.B51 |
| W251.B52 |
| W252.B53 |
| W253.B54 |
| W254.B55 |

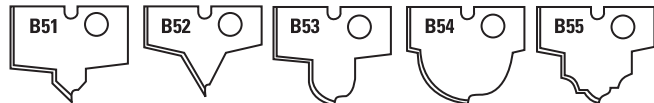

HW INSERT ROUTER BITS "NOVA SYSTEM" Z=2

ART. W263 - W264

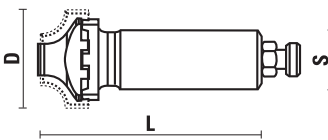

- Patented system
- HW standard knives
- Used on CNC router machines
- Additional knife profiles available on request

| Item | D | L | S |
|---------------------------|-------|------|----|
| W263.000.R only tool body | 35÷38 | 92,5 | 20 |
| W264.000.R only tool body | 35÷38 | 92,5 | 25 |

Add the requested knives

| |
|----------|
| W202.A05 |
| W202.A06 |
| W203.A07 |
| W204.A08 |
| W204.A09 |
| W205.A10 |



On the tool bodies W260 - W261 - W262 - W263 - W264 special profile knives on customer's drawing can fit

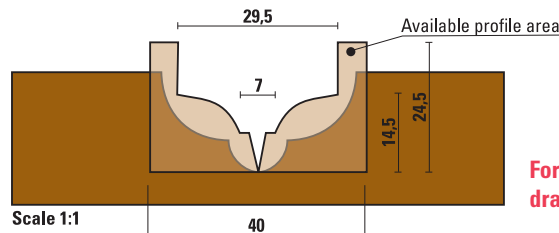
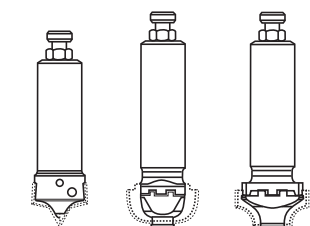

For special knives please provide drawing and quantity requested.

DP ROUTER BITS

ART. X500 - X501 - X502 - X503

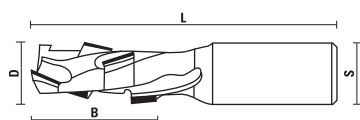

- 2/3 times regrindable
- HW plunging tip
- Recommended for grooving and routing solid hard wood, veneered and laminated MDF
- Used on CNC router machines

| RH rotation | LH rotation | D | B | L | S | Z |
|-------------|-------------|----|----|-----|-------|-----|
| X500.120.R | | 12 | 25 | 75 | 12x35 | 3+1 |
| X500.121.R | | 12 | 34 | 85 | 12x35 | 4+1 |
| X501.160.R | | 16 | 25 | 85 | 16x45 | 3+1 |
| X501.161.R | X501.161.L | 16 | 34 | 94 | 16x45 | 4+1 |
| X501.180.R | | 18 | 25 | 85 | 16x45 | 3+1 |
| X501.181.R | X501.181.L | 18 | 34 | 94 | 16x45 | 4+1 |
| X501.182.R | | 18 | 43 | 103 | 16x45 | 5+1 |
| X502.180.R | X502.180.L | 18 | 25 | 85 | 20x50 | 3+1 |
| X502.181.R | X502.181.L | 18 | 34 | 95 | 20x50 | 4+1 |
| X502.182.R | X502.182.L | 18 | 43 | 103 | 20x50 | 5+1 |
| X502.200.R | X502.200.L | 20 | 25 | 85 | 20x50 | 3+1 |
| X502.201.R | X502.201.L | 20 | 34 | 94 | 20x50 | 4+1 |
| X502.202.R | X502.202.L | 20 | 43 | 103 | 20x50 | 5+1 |
| X502.203.R | X502.203.L | 20 | 53 | 112 | 20x50 | 6+1 |
| X503.160.R | | 16 | 25 | 85 | 25x55 | 3+1 |
| X503.180.R | | 18 | 25 | 85 | 25x55 | 3+1 |
| X503.181.R | X503.181.L | 18 | 34 | 94 | 25x55 | 4+1 |
| X503.182.R | X503.182.L | 18 | 43 | 103 | 25x55 | 5+1 |
| X503.203.R | X503.203.L | 20 | 52 | 112 | 25x55 | 6+1 |



DP ROUTER BITS

ART. X505 - X506

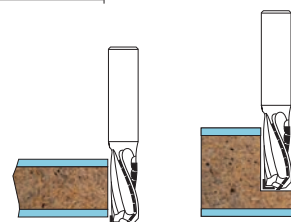
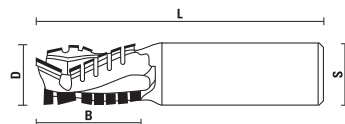

- DP plunging tip
- Recommended for grooving and routing veneered and double-sided laminated boards, also MDF
- Excellent finish on both sides of the workpiece thanks to the alternate shear angle
- Higher feed rate (max. 20.000 m/min)
- Used on CNC router machines

| Item | D | B | L | S | Z | n° Teeth |
|------------|----|----|-----|-------|-----|----------|
| X505.200.R | 20 | 30 | 88 | 20x50 | 3+3 | 11 |
| X505.201.R | 20 | 35 | 95 | 20x50 | 3+3 | 13 |
| X505.202.R | 20 | 42 | 102 | 20x50 | 3+3 | 16 |
| X505.250.R | 25 | 30 | 88 | 20x50 | 3+3 | 11 |
| X505.251.R | 25 | 35 | 95 | 20x50 | 3+3 | 13 |
| X505.252.R | 25 | 45 | 102 | 20x50 | 3+3 | 17 |
| X505.253.R | 25 | 50 | 110 | 20x50 | 3+3 | 19 |
| X506.200.R | 20 | 30 | 88 | 25x50 | 3+3 | 11 |
| X506.201.R | 20 | 35 | 95 | 25x50 | 3+3 | 13 |
| X506.202.R | 20 | 42 | 102 | 25x50 | 3+3 | 16 |
| X506.250.R | 25 | 30 | 88 | 25x50 | 3+3 | 11 |
| X506.251.R | 25 | 35 | 95 | 25x50 | 3+3 | 13 |
| X506.252.R | 25 | 42 | 102 | 25x50 | 3+3 | 17 |
| X506.253.R | 25 | 50 | 110 | 25x50 | 3+3 | 19 |

DP ROUTER BITS

ART. X508 - X509

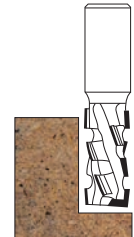
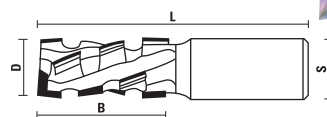

- HW plunging tip
- Used on CNC router machines
- Recommended for grooving and routing solid hard wood, veneered and laminated MDF
- Double number of DP tips compared with items X501÷X503

| RH rotation | LH rotation | D | B | L | S | Z |
|-------------|-------------|----|----|-----|-------|------|
| X508.160.R | | 16 | 25 | 85 | 16x45 | 6+1 |
| X508.161.R | X508.161.L | 16 | 34 | 94 | 16x45 | 8+1 |
| X508.180.R | | 18 | 25 | 85 | 16x45 | 6+1 |
| X508.181.R | X508.181.L | 18 | 34 | 94 | 16x45 | 8+1 |
| X508.182.R | | 18 | 43 | 103 | 16x45 | 10+1 |
| X509.180.R | X509.180.L | 18 | 25 | 85 | 20x50 | 6+1 |
| X509.181.R | X509.181.L | 18 | 34 | 95 | 20x50 | 8+1 |
| X509.182.R | X509.182.L | 18 | 43 | 103 | 20x50 | 10+1 |
| X509.200.R | X509.200.L | 20 | 25 | 85 | 20x50 | 6+1 |
| X509.201.R | X509.201.L | 20 | 34 | 94 | 20x50 | 8+1 |
| X509.202.R | X509.202.L | 20 | 43 | 103 | 20x50 | 10+1 |
| X509.203.R | X509.203.L | 20 | 53 | 112 | 20x50 | 12+1 |



DP ROUTER BITS Z=1

ART. X510

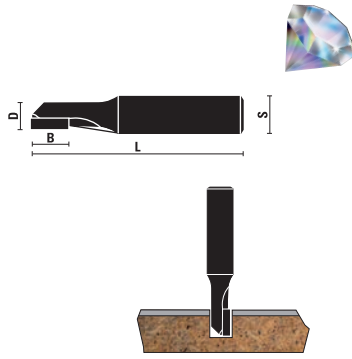

- Right hand rotation
- Solid carbide tool body
- **2/3 times regrindable**
- For cutting and boring on panels of composite materials with lacquered or veneered surfaces
- Best results when working on **phenolic resins and HPL** (Förmica plastic)

| Item | D | B | L | S |
|------------|----|----|----|-------|
| X510.040.R | 4 | 10 | 60 | 12x35 |
| X510.050.R | 5 | 10 | 60 | 12x35 |
| X510.060.R | 6 | 10 | 60 | 12x35 |
| X510.080.R | 8 | 15 | 60 | 12x35 |
| X510.100.R | 10 | 15 | 60 | 12x35 |

DP ROUTER BITS Z=2

ART. X512

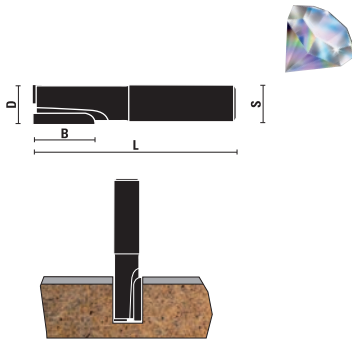

- Right hand rotation
- Solid carbide tool body (only Ø8 - Ø10 - Ø12)
- **2/3 times regrindable**
- For cutting and boring on panels of composite materials with lacquered or veneered surfaces
- Best results when working on **phenolic resins and HPL** (Förmica plastic)

| Item | D | B | L | S |
|------------|----|----|----|-------|
| X512.080.R | 8 | 15 | 60 | 12x35 |
| X512.100.R | 10 | 15 | 60 | 12x35 |
| X512.120.R | 12 | 25 | 70 | 12x35 |
| X512.160.R | 16 | 35 | 80 | 16x40 |

DP ROUTER CUTTERS WITH 40° SHEAR ANGLE

ART. X520 - X521

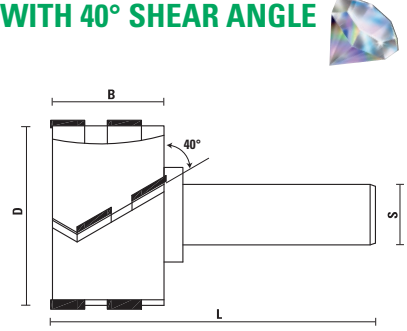

- **40° shear angle**
- Recommended for routing and trimming solid hardwood, MDF, veneered, melamine and HPL panels
- To be used on machining centres and CNC routers
- **DP tip height 4 mm (up to 10 times regrindable)**

| Item | D | B | L | S | Z | n° Teeth |
|-----------------------|----|----|----|-------|-----|----------|
| X520.501.R NEW | 50 | 23 | 80 | 20x55 | 3+3 | 9 |
| X520.502.R NEW | 50 | 23 | 80 | 20x55 | 4+4 | 12 |
| X520.511.R NEW | 50 | 28 | 80 | 20x55 | 3+3 | 15 |
| X520.512.R NEW | 50 | 28 | 80 | 20x55 | 4+4 | 20 |
| X520.521.R NEW | 50 | 38 | 80 | 20x55 | 3+3 | 21 |
| X520.522.R NEW | 50 | 38 | 80 | 20x55 | 4+4 | 28 |

| | | | | | | |
|-----------------------|----|----|----|-------|-----|----|
| X521.501.R NEW | 50 | 23 | 80 | 25x55 | 3+3 | 9 |
| X521.502.R NEW | 50 | 23 | 80 | 25x55 | 4+4 | 12 |
| X521.511.R NEW | 50 | 28 | 80 | 25x55 | 3+3 | 15 |
| X521.512.R NEW | 50 | 28 | 80 | 25x55 | 4+4 | 20 |
| X521.521.R NEW | 50 | 38 | 80 | 25x55 | 3+3 | 21 |
| X521.522.R NEW | 50 | 38 | 80 | 25x55 | 4+4 | 28 |

DP ROUTER BITS H=1,5

ART. X522 - X523

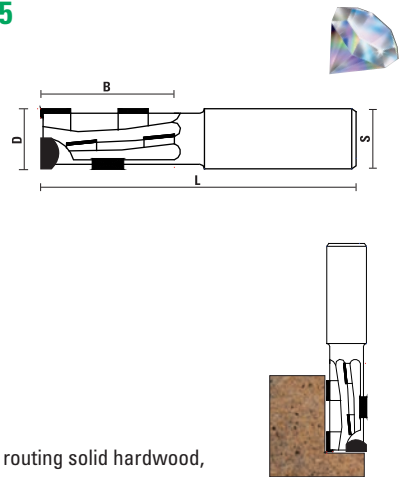

- **DP tip height 1,5 mm**
- Recommended for grooving and routing solid hardwood, veneered and laminated MDF
- **HW plunging tip**
- To be used on CNC router machines

| RH rotation | LH rotation | D | B | L | S | Z | n° Teeth |
|-----------------------|-----------------------|----|----|-----|-------|---|----------|
| X522.180.R NEW | X522.180.L NEW | 18 | 25 | 85 | 20x50 | 3 | 3+1 |
| X522.181.R NEW | X522.181.L NEW | 18 | 36 | 96 | 20x50 | 3 | 4+1 |
| X522.182.R NEW | X522.182.L NEW | 18 | 45 | 105 | 20x50 | 3 | 5+1 |
| X522.200.R NEW | X522.200.L NEW | 20 | 25 | 85 | 20x50 | 3 | 3+1 |
| X522.201.R NEW | X522.201.L NEW | 20 | 36 | 96 | 20x50 | 3 | 4+1 |
| X522.202.R NEW | X522.202.L NEW | 20 | 45 | 105 | 20x50 | 3 | 5+1 |
| X522.203.R NEW | X522.203.L NEW | 20 | 53 | 113 | 20x50 | 3 | 6+1 |
| X523.200.R NEW | X523.200.L NEW | 20 | 25 | 90 | 25x55 | 3 | 3+1 |
| X523.201.R NEW | X523.201.L NEW | 20 | 36 | 100 | 25x55 | 3 | 4+1 |
| X523.202.R NEW | X523.202.L NEW | 20 | 45 | 110 | 25x55 | 3 | 5+1 |
| X523.203.R NEW | X523.203.L NEW | 20 | 53 | 118 | 25x55 | 3 | 6+1 |
| X523.250.R NEW | X523.250.L NEW | 25 | 36 | 100 | 25x55 | 3 | 4+1 |
| X523.251.R NEW | X523.251.L NEW | 25 | 45 | 110 | 25x55 | 3 | 5+1 |
| X523.252.R NEW | X523.252.L NEW | 25 | 53 | 118 | 25x55 | 3 | 6+1 |
| X523.253.R NEW | X523.253.L NEW | 25 | 62 | 127 | 25x55 | 3 | 7+1 |

DP ROUTER BITS FOR NESTING OPERATION

ART. X528

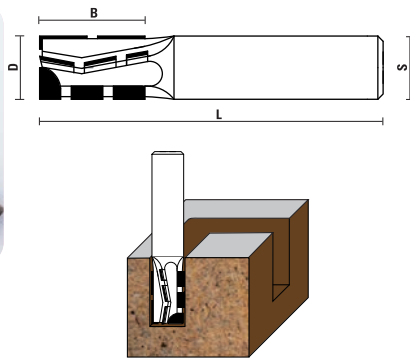

- DP tip height 3 mm (3 times regrindeable)
- Sturdy tool body in high density metal (Densimet®)
- Recommended for **Nesting operations** on chipboard, veneered and laminated MDF
- DP plunging tip
- To be used on CNC router machines
- For improved dust extraction use together with our Art. T139 "Tornado" chip & dust conveyor clamping nut

| Item | D | B | L | S | Z | n° Teeth |
|-----------------------|----|----|----|-------|---|----------|
| X528.120.R NEW | 12 | 20 | 70 | 12x45 | 3 | 8 |
| X528.121.R NEW | 12 | 25 | 75 | 12x45 | 3 | 10 |
| X528.122.R NEW | 12 | 30 | 80 | 12x45 | 3 | 12 |
| X528.123.R NEW | 12 | 35 | 85 | 12x45 | 3 | 14 |

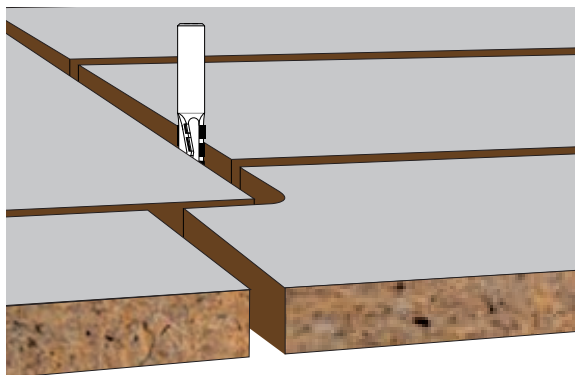

DP DOWEL DRILLS

ART. X530 - X531

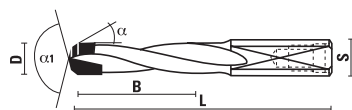

- Shank with flat and screw
- Suitable for drilling very abrasive materials
- Used on CNC router machines

| RH rotation | LH rotation | D | B | L | S | Z |
|-------------|-------------|---|----|------|-------|---|
| X530.050.R | X530.050.L | 5 | 27 | 57,5 | 10x26 | 2 |
| X530.060.R | X530.060.L | 6 | 27 | 57,5 | 10x26 | 2 |
| X530.080.R | X530.080.L | 8 | 27 | 57,5 | 10x26 | 2 |
| X531.050.R | X531.050.L | 5 | 35 | 70 | 10x30 | 2 |
| X531.080.R | X531.080.L | 8 | 35 | 70 | 10x30 | 2 |

DP THROUGH-HOLE DRILL BITS

ART. X532 - X533

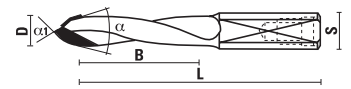

- Shank with flat and screw
- Suitable for drilling very abrasive materials
- Used on CNC router machines

| RH rotation | LH rotation | D | B | L | S | Z |
|-------------|-------------|---|----|------|-------|---|
| X532.050.R | X532.050.L | 5 | 27 | 57,5 | 10x26 | 1 |
| X533.050.R | X533.050.L | 5 | 35 | 70 | 10x26 | 1 |
| X533.060.R | X533.060.L | 6 | 35 | 70 | 10x26 | 2 |
| X533.080.R | X533.080.L | 8 | 35 | 70 | 10x26 | 2 |

DP HINGE BORING BITS

ART. X540 - X541

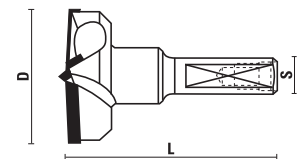

- Shank with flat and screw
- HW centerpoint
- Suitable for drilling very abrasive materials
- Used on CNC router machines

| RH rotation | LH rotation | D | L | S | Z |
|-------------|-------------|----|----|-------|-----|
| X540.150.R | X540.150.L | 15 | 56 | 10x26 | 2+2 |
| X540.160.R | X540.160.L | 16 | 56 | 10x26 | 2+2 |
| X540.180.R | X540.180.L | 18 | 56 | 10x26 | 2+2 |
| X540.200.R | X540.200.L | 20 | 56 | 10x26 | 2+2 |
| X540.250.R | X540.250.L | 25 | 56 | 10x26 | 2+2 |
| X540.260.R | X540.260.L | 26 | 56 | 10x26 | 2+2 |
| X540.300.R | X540.300.L | 30 | 56 | 10x26 | 2+2 |
| X540.350.R | X540.350.L | 35 | 56 | 10x26 | 2+2 |
| X540.400.R | X540.400.L | 40 | 56 | 10x26 | 2+2 |
| X541.150.R | X541.150.L | 15 | 70 | 10x26 | 2+2 |
| X541.200.R | X541.200.L | 20 | 70 | 10x26 | 2+2 |
| X541.250.R | X541.250.L | 25 | 70 | 10x26 | 2+2 |
| X541.350.R | X541.350.L | 35 | 70 | 10x26 | 2+2 |

DP GROOVE CUTTER FOR "LAMELLO"® JOINTS

ART. XAH

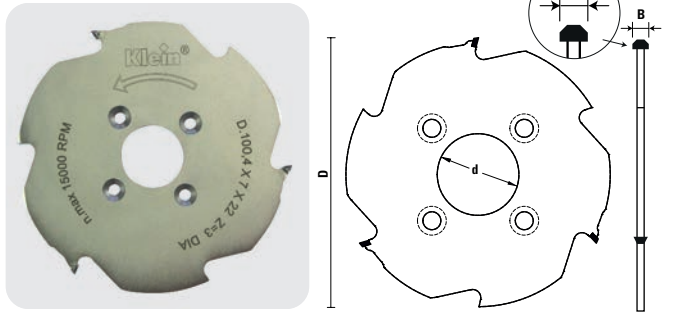

- Suitable for making **Clamex P** connecting fittings for furniture, shelf units and kitchen making
- To be used both on CNC machines and ZETA P2 hand power tool
- Recommended for grooving corner and longitudinal joints on hardwood, veneered and laminated MDF with the P-System anchorage

| Item | D | d | B | Z | Pin holes |
|-------------------------|-------|----|---|---|-----------|
| XAH100.10330 NEW | 100,4 | 30 | 7 | 3 | 4/6,6/48 |
| XAH100.10630 NEW | 100,4 | 30 | 7 | 6 | 4/6,6/48 |
| XAH100.10322 NEW | 100,4 | 22 | 7 | 3 | 4/4/36 |

CLAMEX P JOINTS



P-SYSTEM ANCHORAGE

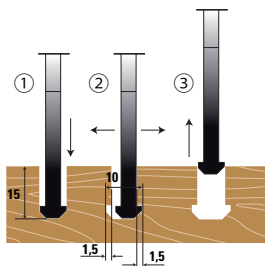

TOOL SET FOR CNC

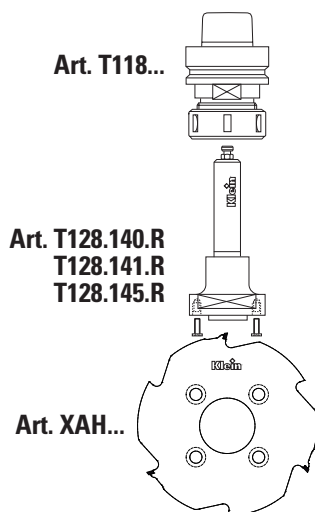

DP SAW BLADES FOR CUTTING ABRASIVE MATERIALS

ART. XGE

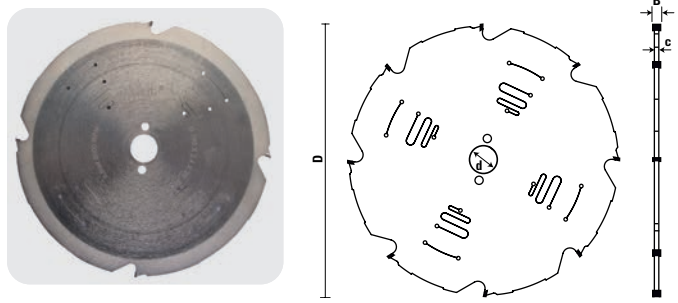

- Suitable for cutting cement fiber, plasterboards, fiber reinforced plastics, solid surface and Eternit
- **DP** flat teeth
- **DP** tooth height 3,5 mm
- = no-noise

Pin holes: **PH02**= 2/7/42 + 2/9,5/46,5 + 2/10/60

| Item | D | d | B/c | Z | Pin holes |
|-------------------------|-----|----|---------|----|-----------|
| XGE160.10420 NEW | 160 | 20 | 2,4/1,6 | 4 | 2/6/32 |
| XGE160.10820 NEW | 160 | 20 | 2,4/1,6 | 8 | 2/6/32 |
| XGE190.10420 NEW | 190 | 20 | 2,4/1,6 | 4 | 2/6/32 |
| XGE200.10430 NEW | 200 | 30 | 2,4/1,6 | 4 | 2/7/42 |
| XGE200.10830 NEW | 200 | 30 | 2,4/1,6 | 8 | 2/7/42 |
| XGE216.10830 NEW | 216 | 30 | 2,4/1,6 | 8 | - |
| XGE230.10630 NEW | 230 | 30 | 2,4/1,6 | 6 | 2/7/42 |
| XGE250.10630 NEW | 250 | 30 | 2,4/1,6 | 6 | PH02 |
| XGE250.11230 NEW | 250 | 30 | 2,4/1,6 | 12 | PH02 |
| XGE300.11230 NEW | 300 | 30 | 2,4/1,6 | 12 | PH02 |
| XGE300.12030 NEW | 300 | 30 | 2,4/1,6 | 20 | PH02 |

visit our website

www.sistemiklein.com



DP SAWBLADES

ART. XFC

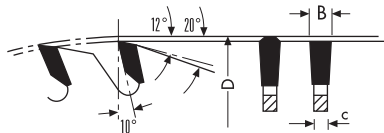

- (FZ/TR) DP triple chip teeth
- For cutting along and across grain of **softwoods, hardwood and exotic timber, double-side veneer laminate boards, MDF and plywood**
- Tooth height **H= 4 mm**

Pin holes: PH02= 2/7/42 + 2/9,5/46,5 + 2/10/60

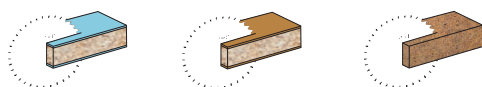

| Item | D | d | B/c | Z | Pin holes |
|--------------|-----|----|---------|----|-----------|
| XFC250.04830 | 250 | 30 | 3,2/2,2 | 48 | PH02 |
| XFC250.06030 | 250 | 30 | 3,2/2,2 | 60 | PH02 |
| XFC300.06030 | 300 | 30 | 3,2/2,2 | 60 | PH02 |
| XFC300.07230 | 300 | 30 | 3,2/2,2 | 72 | PH02 |
| XFC350.07230 | 350 | 30 | 3,5/2,5 | 72 | PH02 |
| XFC350.08430 | 350 | 30 | 3,5/2,5 | 84 | PH02 |
| XFC350.09630 | 350 | 30 | 3,5/2,5 | 96 | PH02 |

DP CONICAL SCORING SAWBLADES

ART. XFI

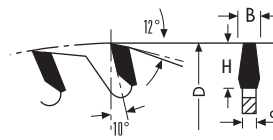

- (KON/FZ) DP conical teeth
- For cutting along and across grain of **softwoods, hardwood and exotic timber, double-side veneer laminate boards, MDF and plywood**
- Tooth height **H= 2,5 mm**

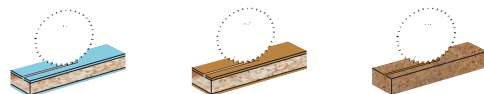

| Item | D | d | B/c | Z | Pin holes |
|--------------|-----|----|-------------|-------|-----------|
| XFI120.02020 | 120 | 20 | 3,1-3,7/2,2 | 20 | |
| XFI120.02022 | 120 | 22 | 3,1-3,7/2,2 | 20 | |
| XFI125.01020 | 125 | 20 | 2,8-3,4/2,2 | 10+10 | |
| XFI125.01022 | 125 | 22 | 2,8-3,4/2,2 | 10+10 | |
| XFI125.02420 | 125 | 20 | 3,1-3,7/2,2 | 20 | |
| XFI125.02422 | 125 | 22 | 3,1-3,7/2,2 | 20 | |
| XFI160.03645 | 160 | 45 | 4,4-5,0/3,2 | 36 | Giben |
| XFI160.03655 | 160 | 55 | 4,4-5,0/3,2 | 36 | Gabbiani |
| XFI180.03620 | 180 | 20 | 4,4-5,0/3,2 | 36 | |
| XFI180.03645 | 180 | 45 | 4,4-5,0/3,2 | 36 | Holzma |
| XFI180.04450 | 180 | 50 | 4,4-5,0/3,2 | 44 | Giben |
| XFI181.03645 | 180 | 45 | 4,8-5,6/3,5 | 36 | Holzma |
| XFI182.03620 | 180 | 20 | 5,8-6,6/4,0 | 36 | Anthon |
| XFI200.03620 | 200 | 20 | 4,4-5,0/3,2 | 36 | |
| XFI200.03630 | 200 | 30 | 4,4-5,0/3,2 | 36 | |
| XFI200.03645 | 200 | 45 | 4,4-5,0/3,2 | 36 | Holzma |
| XFI200.03665 | 200 | 65 | 4,4-5,0/3,2 | 36 | Selco |
| XFI201.03645 | 200 | 45 | 4,8-5,6/3,5 | 36 | Holzma |
| XFI201.03665 | 200 | 65 | 4,8-5,6/3,5 | 36 | Selco |
| XFI202.03620 | 200 | 20 | 5,0-5,8/3,5 | 36 | Schelling |
| XFI203.03645 | 200 | 45 | 5,8-6,6/4,0 | 36 | Holzma |
| XFI215.04250 | 215 | 50 | 4,4-5,0/3,2 | 42 | Giben |

DP ADJUSTABLE SCORING SAWBLADES

ART. XFL

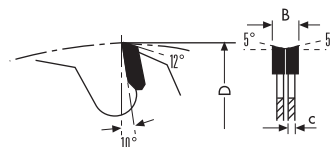

- (LFZ) DP flat teeth
- Supplied with spacers
- For cutting along and across grain of **softwoods, hardwood and exotic timber, double-side veneer laminate boards, MDF and plywood**
- For panel sizing machines
- Tooth height **H= 2,5 mm**

| Item | D | d | B/c | Z |
|--------------|-----|----|-------------|-------|
| XFL125.01020 | 125 | 20 | 2,8-3,4/2,2 | 10+10 |
| XFL125.01022 | 125 | 22 | 2,8-3,4/2,2 | 10+10 |

DP PANEL SIZING SAWBLADES

ART. XHC

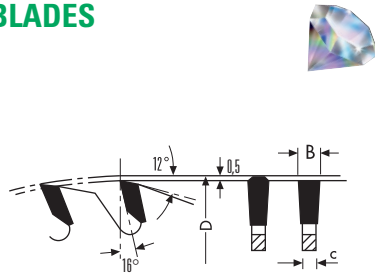

- (FZ/TR) DP triple chip teeth
- For cutting along and across grain of **softwoods, hardwood and exotic timber, double-side veneer laminate boards, MDF and plywood**
- Tooth height **H= 4 mm** (can be produced also with H= 5/6 mm)

Pin holes:

PH01= 2/7/42 + 2/9,5/46,5 + 2/10/60

PH04= 2/14/110 + 2/7/110 + 4/9/100 + 4/19/120 + 2/9/130 (Selco-Gabbani-SCM)

PH05= 4/15/105 + 3/7/100 (Giben-Homag-MacMazza)

| Item | D | d | B/c | Z | Pin holes |
|--------------|-----|----|---------|----|-------------|
| XHC300.06030 | 300 | 30 | 4,4/3,2 | 60 | PH01 |
| XHC300.06065 | 300 | 65 | 4,4/3,2 | 60 | Selco |
| XHC320.06050 | 320 | 50 | 4,4/3,2 | 60 | Giben |
| XHC320.06065 | 320 | 65 | 4,4/3,2 | 60 | Selco |
| XHC330.06050 | 330 | 50 | 4,4/3,2 | 60 | Giben |
| XHC350.07230 | 350 | 30 | 4,4/3,2 | 72 | PH01 |
| XHC350.07250 | 350 | 50 | 4,4/3,2 | 72 | Giben |
| XHC350.07260 | 350 | 60 | 4,4/3,2 | 72 | Holzma |
| XHC350.07265 | 350 | 65 | 4,4/3,2 | 72 | Selco |
| XHC350.07275 | 350 | 75 | 4,4/3,2 | 72 | PH05 |
| XHC350.07280 | 350 | 80 | 4,4/3,2 | 72 | PH04 |
| XHC360.07250 | 360 | 50 | 4,4/3,2 | 72 | Giben |
| XHC360.07265 | 360 | 65 | 4,4/3,2 | 72 | Selco |
| XHC370.07230 | 370 | 30 | 4,4/3,2 | 72 | PH01 |
| XHC380.07260 | 380 | 60 | 4,8/3,5 | 72 | Holzma |
| XHC400.07230 | 400 | 30 | 4,4/3,2 | 72 | 2/10/60 |
| XHC400.07260 | 400 | 60 | 4,4/3,2 | 72 | Anthon |
| XHC400.07275 | 400 | 75 | 4,4/3,2 | 72 | Giben-Homag |
| XHC400.07280 | 400 | 80 | 4,4/3,2 | 72 | PH04 |
| XHC401.07260 | 400 | 60 | 4,8/3,5 | 72 | Holzma |
| XHC420.07260 | 420 | 60 | 4,8/3,5 | 72 | Holzma |
| XHC430.07275 | 430 | 75 | 4,8/3,5 | 72 | Giben |
| XHC430.07280 | 430 | 80 | 4,8/3,5 | 72 | PH04 |
| XHC450.07230 | 450 | 30 | 4,8/3,5 | 72 | Schelling |
| XHC450.07280 | 450 | 80 | 4,8/3,5 | 72 | PH04 |
| XHC451.07260 | 450 | 60 | 4,8/3,5 | 72 | Holzma |
| XHC451.07280 | 450 | 80 | 4,8/3,5 | 72 | PH04 |
| XHC460.07230 | 460 | 30 | 4,4/3,2 | 72 | Schelling |
| XHC470.07275 | 470 | 75 | 4,4/3,2 | 72 | Giben |
| XHC480.07230 | 480 | 30 | 4,4/3,2 | 72 | Schelling |
| XHC481.07260 | 480 | 60 | 4,8/3,5 | 72 | Holzma |
| XHC481.07280 | 480 | 80 | 4,8/3,5 | 72 | Selco |
| XHC500.07260 | 500 | 60 | 4,8/3,5 | 72 | Holzma |
| XHC520.07260 | 520 | 60 | 4,8/3,5 | 60 | Holzma |



DP REVERSIBLE KNIVES

See the full range at section 11 page 11.10



Spare Parts

10

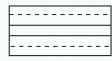

BUSHINGS
Page 10.03

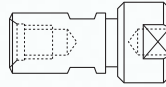

**COLLET CHUCKS WITH
SPRING COLLETS 6 - 8 - 9,5**
Page 10.03



SETTING RINGS
Page 10.03



DRILL HOLDER-SLEEVE
Page 10.03

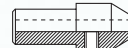

DRILL HOLDERS
Page 10.04



EXTENSION SHAFTS
Page 10.04

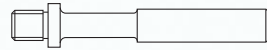

EXTENSION SHAFTS
Page 10.04



**SHAFT ADAPTERS Ø10 FOR
BORING MACHINES**
Page 10.04

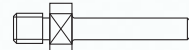

**SHAFT ADAPTERS
FOR PORTABLE ROUTERS**
Page 10.04

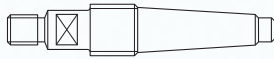

SHAFT ADAPTERS MK2
Page 10.05



ADAPTERS OR EXTENSION SHAFTS
Page 10.05



BALL BEARINGS
Page 10.05



"DELIN"™ BALL BEARINGS
Page 10.05



CHEESE HEAD SCREWS
Page 10.06



SLOTTED CHEESE HEAD SCREWS
Page 10.06



COUNTERSUNK HEAD SCREWS
Page 10.06



DUST PLUG
Page 10.06



SET SCREWS
Page 10.06



ROUNDED HEAD SCREWS
Page 10.06



**HEXAGON SOCKET SET SCREWS
FOR WEDGES**
Page 10.07



ALLEN KEYS
Page 10.07



TORX KEYS
Page 10.07

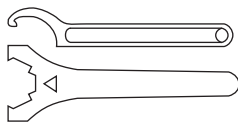

WRENCHES
Page 10.07

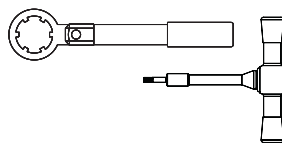

TORQUE WRENCHES
Page 10.08 - 10.09



WASHERS
Page 10.10



SPRING WASHERS
Page 10.10

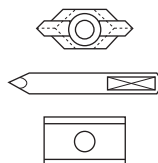

KNIVES
Page 10.10

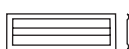

HW "VERSOFIX" KNIVES
Page 10.10

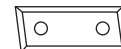

HW STANDARD REVERSIBLE KNIVES
Page 10.10



HW KNIVES
Page 10.11



WEDGES
Page 10.12



SPACERS
Page 10.12



LOCK RING
Page 10.12



O-RING
Page 10.12

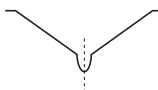

SPRINGS
Page 10.12



THREADED RINGS
Page 10.12

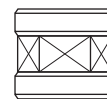

THREADED NUTS FOR MK2 SHANKS
Page 10.13

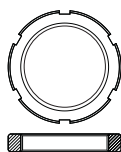

COLLET NUTS
Page 10.13



"NO-NOISE" COLLET NUTS
Page 10.13

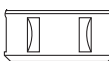

COLLET NUTS
Page 10.13

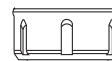

COLLET NUTS WITH BALL BEARINGS
Page 10.13

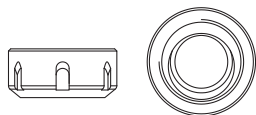

CLAMPING NUT WITH ECCENTRIC RING
Page 10.14

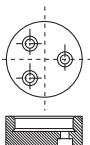

END CAPS
Page 10.14

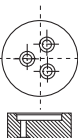

FIXING FLANGE FOR ART. T132.320.NS
Page 10.14



REDUCTION RINGS FOR SAWBLADES
Page 10.14



REDUCTION RINGS FOR CUTTERHEADS
Page 10.15

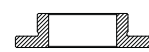

REDUCING BUSHES
Page 10.15

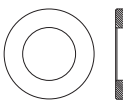

SPACERS AND SPACERS SET
Page 10.16

BUSHINGS

ART. Z001

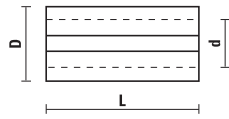

| Item | D | d | L |
|------------|------|-----|----|
| Z001.001.N | 8 | 6 | 25 |
| Z001.002.N | 9,5 | 6 | 25 |
| Z001.003.N | 9,5 | 8 | 25 |
| Z001.004.N | 10 | 8 | 25 |
| Z001.005.N | 12 | 8 | 25 |
| Z001.006.N | 12 | 6 | 25 |
| Z001.007.N | 12 | 10 | 25 |
| Z001.008.N | 16 | 13 | 40 |
| Z001.009.N | 8 | 6,4 | 25 |
| Z001.010.N | 12 | 9,5 | 25 |
| Z001.011.N | 10 | 6 | 25 |
| Z001.012.N | 8 | 5 | 25 |
| Z001.013.N | 8 | 4 | 25 |
| Z001.014.N | 8 | 3 | 25 |
| Z001.015.N | 10 | 5 | 25 |
| Z001.016.N | 10 | 4 | 25 |
| Z001.017.N | 9,5 | 6,4 | 25 |
| Z001.018.N | 12,7 | 9,5 | 25 |
| Z001.019.N | 12,7 | 8 | 25 |
| Z001.020.N | 12,7 | 6,4 | 25 |

COLLET CHUCKS WITH SPRING COLLETS 6 - 8 - 9,5

ART. Z002

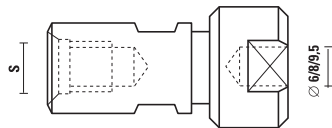

Supplied with nr 3 spring collets Ø6 - Ø8 - Ø9,5

| Item | S |
|------------|----------------------------------|
| Z002.001.R | M12x1 (kit with spring collet) |
| Z002.002.R | M10x1,5 (kit with spring collet) |

Spare parts

| | |
|----------------------------------|--------------------|
| Z002.101.R chuck without collets | M12x1 |
| Z002.102.R chuck without collets | M10x1,5 |
| Z002.160.R | spring collet Ø6 |
| Z002.180.R | spring collet Ø8 |
| Z002.195.R | spring collet Ø9,5 |

SETTING RINGS

ART. Z003

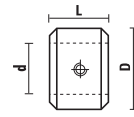

- Rings for setting the drilling depth use when working with manual feed
- Used with Art. R101 - R201 - R 205

| Item | d | D | L |
|------------|----|----|----|
| Z003.050.N | 5 | 16 | 10 |
| Z003.060.N | 6 | 16 | 10 |
| Z003.070.N | 7 | 18 | 10 |
| Z003.080.N | 8 | 18 | 10 |
| Z003.090.N | 9 | 20 | 10 |
| Z003.100.N | 10 | 20 | 10 |
| Z003.120.N | 12 | 22 | 10 |



Z051.301.R



Z052.006.N



1



2

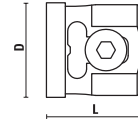
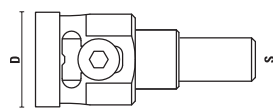

| Item | D | Drawing |
|-----------------------|----|---------|
| Z003.900.N NEW | 32 | 1 |
| Z003.905.N NEW | 25 | 2 |

DRILL HOLDER-SLEEVE

ART. Z010

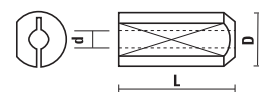

Used with Art. L120



| Item | d | D | L |
|------------|-----|----|----|
| Z010.020.N | 2 | 10 | 24 |
| Z010.025.N | 2,5 | 10 | 24 |
| Z010.030.N | 3 | 10 | 24 |
| Z010.032.N | 3,2 | 10 | 24 |
| Z010.035.N | 3,5 | 10 | 24 |
| Z010.040.N | 4 | 10 | 24 |
| Z010.045.N | 4,5 | 10 | 24 |
| Z010.050.N | 5 | 10 | 24 |
| Z010.060.N | 6 | 10 | 24 |

DRILL HOLDERS

ART. Z011

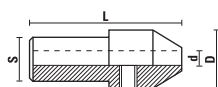

Used with Art. L120



| Item | d | D | L | S |
|------------|-----|----|----|-------|
| Z011.020.N | 2 | 15 | 35 | 10x19 |
| Z011.025.N | 2,5 | 15 | 35 | 10x19 |
| Z011.030.N | 3 | 15 | 35 | 10x19 |
| Z011.032.N | 3,2 | 15 | 35 | 10x19 |
| Z011.035.N | 3,5 | 15 | 35 | 10x19 |
| Z011.040.N | 4 | 15 | 35 | 10x19 |
| Z011.045.N | 4,5 | 15 | 35 | 10x19 |
| Z011.050.N | 5 | 15 | 35 | 10x19 |
| Z011.060.N | 6 | 15 | 35 | 10x19 |



Z051.311.R



Z052.102.N

EXTENSION SHAFTS

ART. Z021

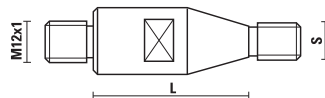
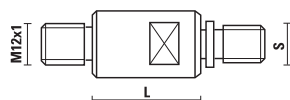

Used with Art. R130

| RH rotation | LH rotation | S | L |
|-------------|-------------|---------|----|
| Z021.025.R | Z021.025.L | M10/11 | 25 |
| Z021.035.R | Z021.035.L | M10/11 | 35 |
| Z021.045.R | Z021.045.L | M10/11 | 45 |
| Z021.125.R | Z021.125.L | M10/30° | 25 |
| Z021.135.R | Z021.135.L | M10/30° | 35 |
| Z021.145.R | Z021.145.L | M10/30° | 45 |

EXTENSION SHAFTS

ART. Z021

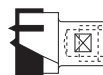
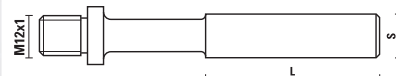

Used with Art. R130 and
Art. F101 - F103 - F104 - F105 - F202 - F203 - F204

| RH rotation | LH rotation | S | L |
|-------------|-------------|----|----|
| Z021.213.R | Z021.213.L | 13 | 50 |
| Z021.216.R | Z021.216.L | 16 | 50 |

SHAFT ADAPTERS Ø10 FOR BORING MACHINES

ART. Z021

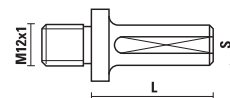

Used with Art. R130

| RH rotation | LH rotation | S | L |
|-------------|-------------|----|----|
| Z021.310.R | Z021.310.L | 10 | 27 |
| Z021.311.R | Z021.311.L | 10 | 40 |
| Z021.312.R | Z021.312.L | 10 | 47 |

SHAFT ADAPTERS FOR PORTABLE ROUTERS

ART. Z021

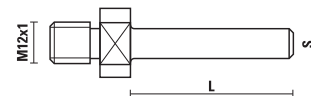

Used with Art. R130 and
Art. F101 - F103 - F104 - F105 - F202 - F203 - F204

| RH rotation | S | L |
|-------------|-----|----|
| Z021.406.R | 6 | 40 |
| Z021.408.R | 8 | 40 |
| Z021.409.R | 9,5 | 40 |
| Z021.410.R | 10 | 40 |
| Z021.412.R | 12 | 40 |

SHAFT ADAPTERS MK2

ART. Z021

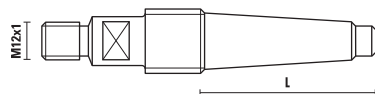

Used with Art. R130

| RH rotation | S | L |
|-------------|---------|----|
| Z021.500.R | MK2/M20 | 67 |

ADAPTERS OR EXTENSION SHAFTS

ART. Z021

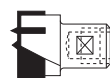
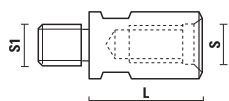

Used with Art. R130
and Art. F101 - F103 - F104 - F105 - F202 - F203 - F204

| RH rotation | S | S1 | L |
|-------------|---------|---------|----|
| Z021.600.R | M12x1 | M12x1 | 25 |
| Z021.601.R | M12x1 | M10x1,5 | 25 |
| Z021.610.R | M10x1,5 | M12x1 | 25 |
| Z021.611.R | M10x1,5 | M10x1,5 | 25 |

BALL BEARINGS

ART. Z050

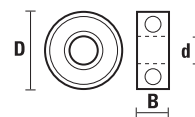

| Item | D | d | B |
|------------|------|------|-----|
| Z050.001.N | 9,5 | 3,2 | 4 |
| Z050.002.N | 9,5 | 4,8 | 3,2 |
| Z050.003.N | 12,7 | 4,8 | 5 |
| Z050.004.N | 16 | 5 | 5 |
| Z050.005.N | 19 | 6,4 | 7,1 |
| Z050.006.N | 19 | 6 | 6 |
| Z050.007.N | 12,7 | 6,4 | 4,7 |
| Z050.008.N | 22 | 8 | 7 |
| Z050.009.N | 25,4 | 15 | 5,5 |
| Z050.010.N | 28 | 8 | 9 |
| Z050.011.N | 15,8 | 6,4 | 5 |
| Z050.012.N | 19 | 12,7 | 4 |
| Z050.013.N | 38 | 15 | 8,5 |
| Z050.014.N | 35 | 15 | 11 |
| Z050.015.N | 28,6 | 12,7 | 8 |
| Z050.016.N | 33,5 | 8 | 8,6 |
| Z050.017.N | 6,4 | 3,2 | 2,8 |
| Z050.018.N | 16 | 8 | 5 |
| Z050.019.N | 14 | 8 | 4 |
| Z050.022.N | 16 | 4,8 | 5 |
| Z050.023.N | 19 | 4,8 | 5 |
| Z050.024.N | 19 | 5 | 5 |

"DELRIN®" BALL BEARINGS

ART. Z050

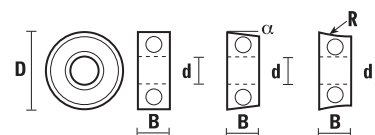

Used for working solid surface (CORIAN®)

| Item | D | d | B | α | R |
|------------|------|-----|-----|-----|--------|
| Z050.100.N | 12,7 | 4,8 | 3,2 | 0° | |
| Z050.101.N | 19 | 6,4 | 5 | 0° | |
| Z050.102.N | 21,8 | 6,4 | 5 | 10° | |
| Z050.103.N | 22,2 | 6,4 | 5 | 5° | |
| Z050.104.N | 28,6 | 15 | 7 | 0° | |
| Z050.105.N | 19 | 6,4 | 6,4 | | R=12,7 |
| Z050.106.N | 25,4 | 6,4 | 7 | 5° | |
| Z050.107.N | 28 | 8 | 8,5 | 0° | |
| Z050.108.N | 29 | 8 | 8,5 | 0° | |
| Z050.109.N | 34 | 8 | 8,5 | 0° | |
| Z050.110.N | 22 | 6 | 7 | 11° | |
| Z050.111.N | 19 | 6 | 7 | 0° | |
| Z050.112.N | 28,6 | 7,9 | 7 | 0° | |
| Z050.113.N | 19,5 | 6,4 | 6,4 | | R=11,9 |
| Z050.120.N | 22,2 | 6,4 | 5 | 10° | |

CHEESE HEAD SCREWS

ART. Z051

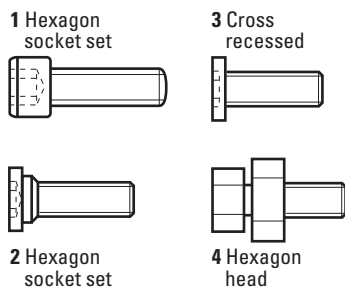

| Item | Description | Draw. |
|------------|--|-------|
| Z051.001.R | M 2,5x12 ch 1,9 | 1 |
| Z051.002.R | M 3,5x13 ch 2,4 | 1 |
| Z051.004.R | M 5x17 ch 4 | 1 |
| Z051.006.R | M 2,2x8 for art. A119.064.R | 3 |
| Z051.007.R | M 5x13 ch 3 for art. E316 | 2 |
| Z051.008.R | M 3x12 ch 2,4 | 1 |
| Z051.012.R | M 5x16 ch 4 for art. R110.600.R | 1 |
| Z051.013.R | M 6,3x19 ch 4,7 for art. R110.800.R | 1 |
| Z051.016.R | M 6x25 ch 5 for art. T128 cutter arbors | 1 |
| Z051.050.R | anti dust set for art. WE178 | |
| Z051.312.R | M 5x10 for NOVASYSTEM | 1 |
| Z051.401.R | M 8x10 | 1 |
| Z051.408.R | M 6x8 for art. W168 | 1 |
| Z051.409.R | M 5x16 for art. W168 | 1 |
| Z051.506.R | M 8x30 hex socket 13 complete with hexagon nut for art. T128.140.R | 4 |

COUNTERSUNK HEAD SCREWS

ART. Z051

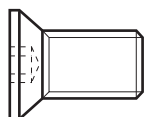

| Item | Description |
|------------|--|
| Z051.011.R | M 4x8 Torx T15 |
| Z051.014.R | M 6x10 for art. T128.140.R slotted head |
| Z051.015.R | M 5x15 ch 3 for art. A/B/C/E/G - 117.280.R |
| Z051.018.R | M 4x12 for art. T128.141.R |
| Z051.020.R | M 5x6,75 ch 3 for art. W190 |
| Z051.024.R | M 6x15 for art. Z092 |
| Z051.205.R | M 5x12,3 Torx T20 for art. W190 |
| Z051.307.R | M 5x6 |
| Z051.309.R | M 3x6 Torx T9 |
| Z051.310.R | M 3x8 Torx T9 |
| Z051.315.R | M 4x6,5 Torx T9 |
| Z051.403.R | M 5x6 Torx T20 |
| Z051.405.R | M 5x15 ch 2,5 |
| Z051.700.R | M 4x3,2 Torx T15 |
| Z051.701.R | M 5x7 Torx T15 |

DUST PLUG

ART. Z051

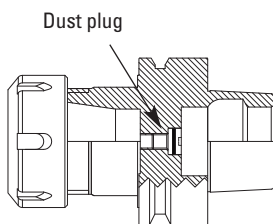
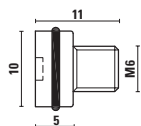

- To be used with our HSK toolholders to avoid any contamination of dust into the electrospindle.
- Inexpensive and easy to use.

| Item | Description |
|-----------------------|-------------|
| Z051.070.N NEW | M6x6 |

SET SCREWS

ART. Z051

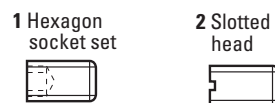

| Item | Description | Draw. |
|------------|--|-------|
| Z051.005.R | M 3x2,5 ch 1,6 with flat point | 1 |
| Z051.101.R | M 2,5x2,5 ch 1,3 with flat point | 1 |
| Z051.102.R | M 4x4 ch 2 with flat point | 1 |
| Z051.300.R | M 6x6 ch 3 with cone point for L130 D=∅ 8÷12 | 1 |
| Z051.301.R | M 5x5 ch 2,5 with flat point | 1 |
| Z051.302.R | M 5x10 | 2 |
| Z051.303.R | M 5x6 ch 2,5 with cone point for art. L130 D=∅ 4÷8 1 | |
| Z051.304.R | M 6x6 ch 3 with flat point for art. L131 D=∅ 10÷12 1 | |
| Z051.306.R | M 5x6 ch 2,5 with cone point | 1 |
| Z051.311.R | M 4x5 ch 2 with flat point for art. Z011 | 1 |
| Z051.313.R | M 5x4 ch 2,5 with flat point | 1 |
| Z051.314.R | M 6x5 ch 3 with flat point for art. L131 D=∅ 10 1 | |
| Z051.321.R | M 3x5 ch 1,6 | 1 |
| Z051.324.R | M 5x3 ch 1,6 for art. R155÷R159 | 1 |
| Z051.404.R | M 3x6 ch 1,5 with cone point for art. W182 | 1 |
| Z051.407.R | M 6x10 ch 3 | 1 |
| Z051.704.R | M 8x12 ch 4 with cyl point for art. SA | 1 |
| Z051.705.R | M 8x16 ch 4 with cyl point for art. SA | 1 |

ROUNDED HEAD SCREWS

ART. Z051

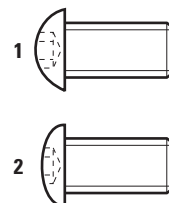

| Item | Description | Draw. |
|------------|-------------------------------------|-------|
| Z051.010.R | M 4x8 - ∅ 9 - T15 | 1 |
| Z051.201.R | M 4x9 - ∅ 7,8 - T15 | 1 |
| Z051.210.R | M 3,5x7 - ∅ 7,8 - T15 | 2 |
| Z051.211.R | M 3,5x7 - ∅ 9 - T15 | 1 |
| Z051.212.R | M 3,5x6,6 for art. W170 - ∅ 6 - T15 | 1 |
| Z051.214.R | M 5x7 ch 2,5 for art. R155 e R159 | 1 |
| Z051.308.R | M 3x6 - T9 - ∅ 5,5 | 1 |
| Z051.320.R | M 3x4 | 1 |
| Z051.400.R | M 4x6 for art. W178 - ∅ 8 | 1 |
| Z051.402.R | M 4x8 for art. W171/W176 - ∅ 9 | 1 |
| Z051.406.R | M 4x3,2 for art. W182 | 1 |
| Z051.702.R | M 5x10 for art. TTL | 1 |

SLOTTED CHEESE HEAD SCREWS

ART. Z051

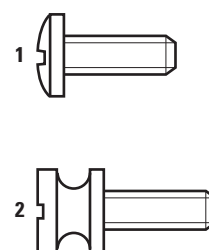

| Item | Description | Draw. |
|------------|---------------------------------|-------|
| Z051.501.R | M 3x4 for spare knife art. WC | 1 |
| Z051.503.R | M 3x10 for ball bearing art. WC | 1 |
| Z051.505.R | M 5x17 for machines Weeke | 2 |

HEXAGON SOCKET SET SCREWS FOR WEDGES

ART. Z051

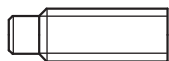

| Item | Description | For item |
|------------|-------------------|----------|
| Z051.800.R | M 5x18 | TA/TB/TC |
| Z051.801.R | M 7x21 | TB |
| Z051.802.R | M 8x21 | THL |
| Z051.803.R | M 6x10 | TI 120 |
| Z051.804.R | M 6x12 | TI 160 |
| Z051.805.R | M 8x20 | TLL |
| Z051.807.R | M 6x20 | TYL |
| Z051.808.R | M 6x25 | TWL |
| Z051.809.R | M 8x18 | TZA |
| Z051.810.R | M 8x16 | TEL |
| Z051.811.R | M 4x10 - Torx T15 | TIL |

ALLEN KEYS

ART. Z052



| Item | Description |
|------------|--|
| Z052.001.N | ch 1,9 |
| Z052.002.N | ch 2,4 |
| Z052.003.N | ch 4 |
| Z052.005.N | ch 1,6 |
| Z052.006.N | ch 2,5 for art. L001.100L/R |
| Z052.007.N | ch 1,5 |
| Z052.013.N | ch 4,7 for art. R110.800.R |
| Z052.055.N | ch 1,6 and ch 2,5 for art. R156 and R159 |
| Z052.101.N | ch 1,3 |
| Z052.102.N | ch 2 |
| Z052.103.N | ch 3 for art. W168 |
| Z052.104.N | ch 4 for art. W168 |
| Z052.406.N | ch 3 for art. SB080 |

TORX KEYS

ART. Z052



| Item | Description |
|------------|-------------|
| Z052.004.N | Torx T10 |
| Z052.201.N | Torx T15 |
| Z052.205.N | Torx T20 |
| Z052.302.N | Torx T9 |

WRENCHES

ART. Z052

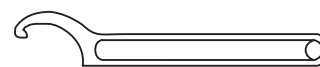

| Item | Description | Collet nut |
|------------|--|---------------|
| Z052.300.N | Wrench 34/38 | DIN6388/EOC12 |
| Z052.305.N | Wrench 45/50 | Z091.005.R |
| Z052.301.N | Wrench 40/42 | Z091.000.R |
| Z052.310.N | Wrench 58/62 | DIN6388/EOC25 |
| Z052.314.N | Wrench for dust & chip extraction nut D=80 | |
| Z052.315.N | Wrench for dust & chip extraction nut D=92 | |

WRENCHES FOR COLLET NUT "STANDARD"

ART. Z052



| Item | Description |
|------------|---|
| Z052.401.N | Wrench for collet nut ER 32 "standard" type |
| Z052.402.N | Wrench for collet nut ER 40 "standard" type |
| Z052.404.N | Wrench for collet nut ER 20 "standard" type |
| Z052.407.N | Wrench for collet nut ER 25 "standard" type |
| Z052.409.N | Wrench for collet nut ER 16 "standard" type |

WRENCHES FOR COLLET NUT "MINI"

ART. Z052

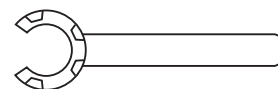

| Item | Description |
|------------|---|
| Z052.503.N | Wrench for collet nut ER 25 "mini" type |
| Z052.505.N | Wrench for collet nut ER 16 "mini" type |
| Z052.508.N | Wrench for collet nut ER 20 "mini" type |
| Z052.511.N | Wrench for collet nut ER 11 "mini" type |

TORQUE WRENCHES

While setting a tool it is extremely important to tighten it properly.

If not effectively tight indeed a cutting tool could slide away from the tool holder during the working process. On the other side, an excessive tightening can cause damages to the tool holder or spring collet or the tool itself.

The wrench indicates when the torque (Nm) is reached according to the value indicated, in order to avoid any damages.

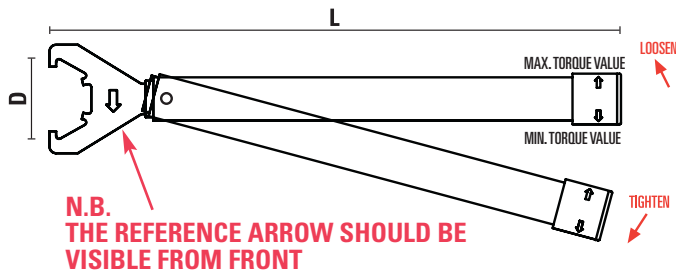

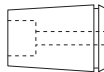
Dr. ①  Collets as per drawing n. 1 must be tightened by setting the minimum torque value and rotating the handle counterclockwise.

Dr. ②  Collets as per drawing n. 2 must be tightened by setting the maximum torque value and rotating the handle clockwise.

TORQUE WRENCHES FOR "MINI" NUTS

ART. Z052

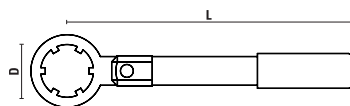

| Item | D | L | Nm | Threaded nut |
|------------|----|-----|----|--------------|
| Z052.701.N | 16 | 120 | 18 | ER11 |
| Z052.702.N | 22 | 175 | 28 | ER16 |
| Z052.703.N | 28 | 180 | 35 | ER20 |
| Z052.704.N | 35 | 185 | 40 | ER25 |

TORQUE WRENCHES FOR "STANDARD" NUTS

ART. Z052

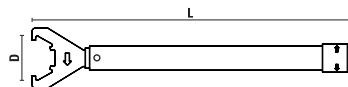

| Item | D | L | Nm (Dr. 1) | Nm (Dr. 2) | Threaded nut |
|------------|----|-----|------------|------------|--------------|
| Z052.710.N | 32 | 380 | 25-35 | 45-55 | ER16 |
| Z052.711.N | 35 | 380 | 30-40 | 60-70 | ER20 |
| Z052.712.N | 40 | 400 | 40-55 | 80-90 | ER25 |
| Z052.713.N | 50 | 400 | 66-70 | 120-130 | ER32 |
| Z052.714.N | 63 | 450 | 110-120 | 190-200 | ER40 |

TORQUE WRENCHES FOR TORNADO®

ART. Z052



| Item | Type | L | Nm (dis. 1) | Nm (dis. 2) |
|-----------------------|-------|-----|-------------|-------------|
| Z052.722.N NEW | ER25 | 480 | 40-55 | 80-90 |
| Z052.723.N NEW | ER32 | 480 | 66-70 | 120-130 |
| Z052.724.N NEW | ER40 | 480 | 110-120 | 190-200 |
| Z052.728.N NEW | EOC25 | 480 | 110-120 | 190-200 |

TORQUE HOOK WRENCHES

ART. Z052

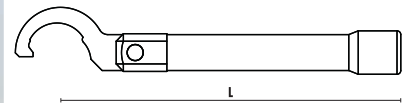

| Item | D | L | Nm (Dr. 1) | Nm (Dr. 2) | Threaded nut |
|-----------------------|-------|-----|------------|------------|----------------|
| Z052.732.N | 58-62 | 380 | 110-120 | 190-200 | DIN 6388/EOC25 |
| Z052.735.N NEW | 50 | 380 | 110-120 | 190-200 | Z091.005.R |

TORQUE WRENCHES FOR "NO-NOISE" NUTS

ART. Z052

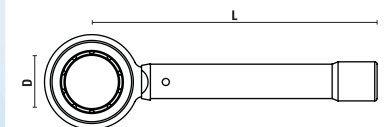

| Item | D | L | Nm (Dr. 1) | Nm (Dr. 2) | Threaded nut |
|------------|----|-----|------------|------------|----------------|
| Z052.790.N | 32 | 400 | 25-35 | 45-55 | ER 16 |
| Z052.793.N | 50 | 400 | 65-70 | 120-130 | ER 32 |
| Z052.795.N | 60 | 400 | 110-120 | 190-200 | DIN 6388/EOC25 |

While tightening with constant action a strong shot is perceived both mechanically and acoustically. This indicates that the set torque is reached.

TORQUE WRENCHES FOR "TORX" SCREWS

ART. Z052

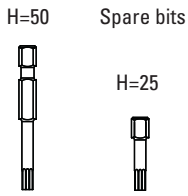
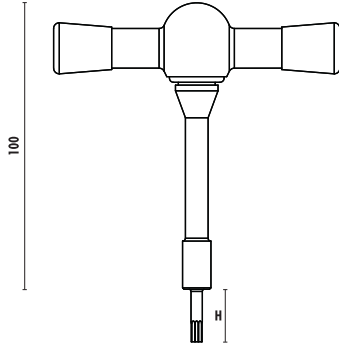

Supplied with H=25

| Item | Torx | Nm |
|------------|------|-----|
| Z052.748.N | T6 | 0,6 |
| Z052.749.N | T7 | 0,9 |
| Z052.750.N | T8 | 1,2 |
| Z052.751.N | T9 | 1,4 |
| Z052.752.N | T10 | 2 |
| Z052.753.N | T15 | 3 |
| Z052.754.N | T20 | 5 |
| Z052.755.N | T25 | 7,2 |

| Spare parts | Torx | H |
|----------------|------|----|
| Z052.748.NCH25 | T6 | 25 |
| Z052.749.NCH25 | T7 | 25 |
| Z052.750.NCH25 | T8 | 25 |
| Z052.750.NCH50 | T8 | 50 |
| Z052.751.NCH25 | T9 | 25 |
| Z052.751.NCH50 | T9 | 50 |
| Z052.752.NCH25 | T10 | 25 |
| Z052.752.NCH50 | T10 | 50 |
| Z052.753.NCH25 | T15 | 25 |
| Z052.753.NCH50 | T15 | 50 |
| Z052.754.NCH25 | T20 | 25 |
| Z052.754.NCH50 | T20 | 50 |
| Z052.755.NCH25 | T25 | 25 |
| Z052.755.NCH50 | T25 | 50 |

Insert bits in 5 pieces box

TORQUE WRENCHES FOR "HEX" SCREWS

ART. Z052

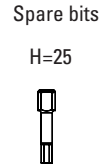
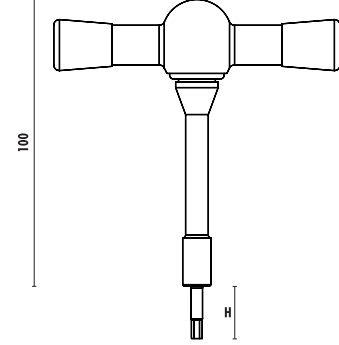

Supplied with H=25

| Item | Socket size | Nm | Used on screw |
|------------|-------------|------|---------------|
| Z052.771.N | 1,3 | 0,10 | Z051.101.R |
| Z052.772.N | 1,5 | 0,12 | Z051.404.R |
| Z052.773.N | 2 | 0,50 | Z051.001.R |
| Z052.774.N | 2,4 | 0,76 | Z051.002.R |
| Z052.775.N | 4 | 3,10 | Z051.004.R |
| Z052.776.N | 5 | 5,00 | Z051.016.R |
| Z052.785.N | 1,6 | 3,00 | Z051.005.R |
| Z052.786.N | 2,5 | 5,00 | Z051.301.R |
| Z052.787.N | 3 | 7,00 | Z051.314.R |

| Spare parts | Socket size |
|----------------|-------------|
| Z052.771.NCH25 | 1,3 |
| Z052.772.NCH25 | 1,5 |
| Z052.773.NCH25 | 2 |
| Z052.774.NCH25 | 2,4 |
| Z052.775.NCH25 | 4 |
| Z052.776.NCH25 | 5 |
| Z052.785.NCH25 | 1,6 |
| Z052.786.NCH25 | 2,5 |
| Z052.787.NCH25 | 3 |

Insert bits in 5 pieces box

WASHERS

ART. Z053



| Item | D | d |
|------------|------|-----|
| Z053.001.N | 9,5 | 3,2 |
| Z053.002.N | 8 | 4,8 |
| Z053.003.N | 12,7 | 4,8 |
| Z053.004.N | 16 | 5 |
| Z053.010.N | 9,5 | 6,4 |

SPRING WASHERS

ART. Z054



| Item | D | d |
|------------|-----|-----|
| Z054.001.N | 6 | 2,5 |
| Z054.002.N | 7,5 | 3,2 |
| Z054.003.N | 11 | 6,4 |
| Z054.410.N | 9,5 | 6,4 |

KNIVES

ART. Z055

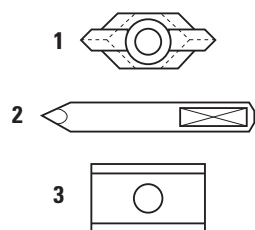

10 pcs. set

| Item | Drawing | |
|------------|---------|------------------|
| Z055.100.N | 1 | spur |
| Z055.101.N | 2 | centerpoint |
| Z055.125.N | 3 | HW-knife for Ø25 |
| Z055.126.N | 3 | HW-knife for Ø26 |
| Z055.130.N | 3 | HW-knife for Ø30 |
| Z055.135.N | 3 | HW-knife for Ø35 |
| Z055.140.N | 3 | HW-knife for Ø40 |

HW "VERSOFIX" KNIVES

ART. Z055

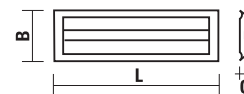

10 pcs. set

- With "Kawedur" coating
- 4 cutting edges
- Spare parts for W120-W127 and W138

| Item | L | B | C |
|------------|----|-----|-----|
| Z055.220.N | 20 | 5,5 | 1,1 |
| Z055.221.N | 20 | 10 | 1,5 |
| Z055.230.N | 30 | 6,5 | 1,1 |
| Z055.231.N | 30 | 10 | 1,5 |
| Z055.250.N | 50 | 10 | 1,5 |

HW STANDARD REVERSIBLE KNIVES

ART. Z055

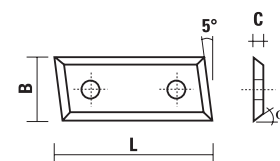

10 pcs. set

- 4 cutting edges
- 2 fixing holes
- 5° right
- Spare parts for Art. W153 - W154 - W155 - W156

| Item | Grade | L | B | C | α |
|------------|-------|----|----|-----|----------|
| Z055.423.N | HC05 | 30 | 9 | 1,5 | 35° |
| Z055.424.N | HC05 | 40 | 9 | 1,5 | 35° |
| Z055.425.N | HC05 | 50 | 9 | 1,5 | 35° |
| Z055.430.N | HC05 | 30 | 12 | 1,5 | 35° |
| Z055.440.N | HC05 | 40 | 12 | 1,5 | 35° |
| Z055.450.N | HC05 | 50 | 12 | 1,5 | 35° |

HW KNIVES

ART. Z055

| Item | Description | For item |
|------------|---------------------------|----------------|
| Z055.330.N | 29,5x9x1,5 | WC101 |
| Z055.500.R | 50x5,5x1,1 | W174 - W175 |
| Z055.500.L | 50x5,5x1,1 Sx | W174 - W175 |
| Z055.501.N | 16x7x1,5 (1 chip breaker) | W172 - W173 |
| Z055.502.N | 16x7x1,5 (2 chip breaker) | W172 - W173 |
| Z055.503.N | 23x7x1,5 (1 chip breaker) | W172 - W173 |
| Z055.504.N | 23x7x1,5 (2 chip breaker) | W172 - W173 |
| Z055.505.N | 48x12x1,5 | W171 |
| Z055.506.N | 27x9x1,5 | W170.210.R+260 |
| Z055.507.N | 28x12x1,5 | W170.380.R |
| Z055.516.N | 16x7x1,5 | W165 |
| Z055.528.N | 28x7x1,5 | W165 |
| Z055.529.N | 29,5x5,5x1,1 | WE101.120.R |
| Z055.520.N | R= 3 | WE152.250.R |
| Z055.521.N | R= 6 | WE152.280.R |
| Z055.522.N | R= 8 | WE152.320.R |
| Z055.523.N | R= 10 | WE152.360.R |
| Z055.550.N | R= 6 | WC111 |
| Z055.551.N | 20x9x1,5 | WC120 |
| Z055.552.N | 13,25x9x1,1 | WC121 |
| Z055.553.N | R= 3/45° | WC122 |
| Z055.554.N | R= 6 | WC123 |
| Z055.555.N | R= 6 | WC125 |
| Z055.556.N | R= 4,5 | WC129 |
| Z055.560.N | 33,3x18,5x2 | W178.860.R |
| Z055.561.N | 31x17x2 | W178.861.R |
| Z055.562.N | 32x20x1,5 | W178.862.R |
| Z055.569.N | 13,9x9,5x2 - R=8 | W178.999.R |
| Z055.571.N | 40x19x2 | WE180 |
| Z055.572.N | R= 6,4 | WE112 |
| Z055.573.N | R= 8 | WE112 |
| Z055.574.N | R= 9,5 | WE112 |
| Z055.575.N | R= 12,7 | WE112 |
| Z055.580.N | 30x23x2 | WE194 |
| Z055.581.N | 30x23x2 | WE194 |
| Z055.582.N | 30x23x2 | WE195 |
| Z055.583.N | 30x23x2 | WE195 |
| Z055.584.N | 30x23x2 | WE197 |
| Z055.585.N | 30x23x2 | WE197 |
| Z055.586.N | 30x23x2 | WE198 |
| Z055.587.N | 30x23x2 | WE198 |
| Z055.628.N | 40x28x1,5 | WE180 - W181 |
| Z055.641.N | Profile C1 - 45° | W162 |
| Z055.642.N | Profile C2 - R= 4/45° | W162 |
| Z055.643.N | Profile C3 - R= 1/11 | W162 |
| Z055.644.N | Profile C4 - R= 3° | W162 |
| Z055.645.N | Profile C5 - R= 8/30° | W162 |
| Z055.646.N | Profile C6 - R= 4/2 | W162 |
| Z055.647.N | Profile C7 - R= 12 | W162 |
| Z055.648.N | Profile C8 - R= 3/2 | W162 |
| Z055.649.N | Profile C9 - R= 2/10 | W162 |
| Z055.650.N | Profile C10 - R= 45°/2 | W162 |
| Z055.651.N | Profile B1 - R= 12x4 | W161 |
| Z055.652.N | Profile B2 - R= 12 | W161 |
| Z055.653.N | Profile B3 - R= 15 | W161 |
| Z055.654.N | Profile B4 - R= 3/R3 | W161 |
| Z055.655.N | Profile B5 - R= 26/5 | W161 |
| Z055.656.N | Profile B6 - R= 6/1,5 | W161 |

| Item | Item | Description | For item |
|------------|------------|-----------------------|-----------|
| Z055.661.N | | Profile A1 - R= 10/4 | W160 |
| Z055.662.N | | Profile A2 - R= 6/6 | W160 |
| Z055.663.N | | Profile A3 - R= 5/6 | W160 |
| Z055.664.N | | Profile A4 - R= 15/14 | W160 |
| Z055.665.N | | Profile A5 - R= 3/20° | W160 |
| Z055.666.N | | Profile A6 - R= 5/20° | W160 |
| Z055.800.R | Z055.800.L | R= 2/45° | TLL |
| Z055.801.R | Z055.801.L | R= 3/45° | TLL |
| Z055.802.R | Z055.802.L | R= 4/45° | TLL |
| Z055.803.R | Z055.803.L | R= 5/45° | TLL |
| Z055.804.R | Z055.804.L | R= 6/45° | TLL |
| Z055.805.R | | R= 3/6 | TML |
| Z055.806.R | | R= 4/8 | TML |
| Z055.807.R | | R= 5/10 | TML |
| Z055.808.R | | R= 12/18 | TML |
| Z055.809.R | | R= 15/20 | TML |
| Z055.810.R | | R= 4/4 | TNL |
| Z055.811.R | | R= 6/6 | TNL |
| Z055.812.R | | R= 8/8 | TNL |
| Z055.813.R | | R= 10/10 | TNL |
| Z055.814.R | | R= 12/12 | TNL |
| Z055.815.R | | R= 15/15 | TNL |
| Z055.830.R | | 45° | TSL |
| Z055.831.N | | Profile A | TTL |
| Z055.832.N | | Profile B | TTL |
| Z055.833.N | | Profile C | TTL |
| Z055.834.N | | Profile D | TTL |
| Z055.835.N | | Profile E | TTL |
| Z055.836.N | | Profile F | TTL |
| Z055.841.R | | Profile A | TVL |
| Z055.842.R | | Profile B | TVL |
| Z055.843.N | | Profile A | TWL |
| Z055.844.N | | Profile B | TWL |
| Z055.845.N | | Profile C | TWL |
| Z055.846.N | | Profile D | TWL |
| Z055.847.N | | Profile A4 | TZL |
| Z055.848.N | | Profile B4 | TZL |
| Z055.851.R | | Profile A1 | TYL |
| Z055.852.R | | Profile A2 | TYL |
| Z055.853.R | | Profile B1 | TYL |
| Z055.854.R | | Profile B2 | TYL |
| Z055.855.R | | Profile C1 | TYL |
| Z055.856.R | | Profile C2 | TYL |
| Z055.857.R | | Profile D1 | TYL |
| Z055.858.R | | Profile D2 | TYL |
| Z055.859.R | | Profile E1 | TYL |
| Z055.860.R | | Profile E2 | TYL |
| Z055.861.N | | Profile A1 | TS |
| Z055.862.N | | Profile A2 | TS |
| Z055.863.N | | Profile B1 | TS |
| Z055.864.N | | Profile B2 | TS |
| Z055.870.R | Z055.870.L | R= 3 | W184+W185 |
| Z055.871.R | Z055.871.L | R= 4 | W184+W185 |
| Z055.872.R | Z055.872.L | R= 5 | W184+W185 |
| Z055.873.R | Z055.873.L | R= 6 | W184+W185 |
| Z055.874.R | Z055.874.L | R= 8 | W184+W185 |
| Z055.875.R | Z055.875.L | R= 10 | W184+W185 |
| Z055.876.R | Z055.876.L | 45° | W184+W185 |

WEDGES

ART. Z056



| Item | Description | For item |
|------------|-----------------------------|-----------|
| Z056.100.N | 40x22,5x4 | W180 |
| Z056.101.N | 40x13,5x8 | W180/W181 |
| Z056.102.N | L= 6,5 | W182 |
| Z056.700.N | L= 6,8 | TA/TC |
| Z056.701.N | L= 14 | TB |
| Z056.702.N | L= 46 | TEL |
| Z056.703.N | L= 26 | TF |
| Z056.704.N | 45° | THL |
| Z056.705.N | L= 37 | TI |
| Z056.706.N | L= 47 | TI 160 |
| Z056.707.N | wedge | TLL |
| Z056.708.N | wedge | TLL |
| Z056.709.N | D= 112/113 | TML |
| Z056.710.N | D= 109/132 | TML |
| Z056.711.N | D= 122 | TNL |
| Z056.712.N | R= 8/9/10 | TOL |
| Z056.719.N | 45° | TSL |
| Z056.721.N | for profile A | TVL |
| Z056.722.N | for profile B | TVL |
| Z056.723.N | for profiles A/B/C/D | TWL |
| Z056.724.N | for profiles A1/B1/C1/D1/E1 | TYL |
| Z056.725.N | for profiles A2/B2/C2/D2/E2 | TYL |
| Z056.726.N | L= 46 | TS |
| Z056.760.N | L= 120 | TZA |
| Z056.761.N | L= 130 | TZA |
| Z056.762.N | L= 150 | TZA |
| Z056.763.N | L= 180 | TZA |
| Z056.764.N | L= 230 | TZA |
| Z056.765.N | L= 38 | W168 |
| Z056.790.N | 38x24x13 | SA |
| Z056.791.N | 38x15x16 | SA |
| Z056.800.N | wedges | TSL/THL |

SPACERS

ART. Z057

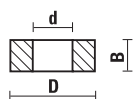

| Item | D | d | B |
|------------|-----|------|------|
| Z057.001.N | 16 | 7,94 | 3,6 |
| Z057.002.N | 16 | 7,94 | 1 |
| Z057.003.N | 16 | 7,94 | 0,5 |
| Z057.004.N | 16 | 7,94 | 0,1 |
| Z057.005.N | 16 | 7,94 | 3 |
| Z057.006.N | 16 | 7,94 | 6 |
| Z057.007.N | 16 | 7,94 | 0,4 |
| Z057.008.N | 16 | 7,94 | 0,05 |
| Z057.009.N | 16 | 7,94 | 5,3 |
| Z057.010.N | 9,5 | 6,4 | 2,2 |
| Z057.101.N | 10 | 6 | 1 |
| Z057.102.N | 10 | 6 | 1,5 |
| Z057.103.N | 10 | 6 | 3 |

LOCK RING

ART. Z058

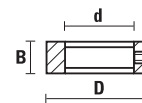

| Item | D | d | B |
|------------|------|------|---|
| Z058.001.N | 11 | 6,4 | 5 |
| Z058.002.N | 18,2 | 12,7 | 6 |
| Z058.003.N | 20 | 12,7 | 6 |

O-RING

ART. Z059



| Item | D | Rotation |
|------------|-----|---------------------|
| Z059.001.L | 8,5 | Left (red color) |
| Z059.001.R | 8,5 | Right (black color) |

SPRINGS

ART. Z060

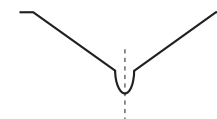

| Item | Description | For item |
|------------|-------------|----------|
| Z060.100.N | 36x95 | TZA |

THREADED RINGS

ART. Z060

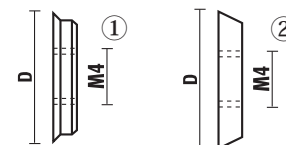

| Item | Description | For item | Drawing |
|------------|--------------|----------|---------|
| Z060.700.R | thread M4/10 | TA | 1 |
| Z060.701.R | thread M4/12 | TA | 2 |
| Z060.750.N | thread M4/12 | W182 | 2 |
| Z060.751.N | thread M4/10 | W182 | 1 |

THREADED NUTS FOR MK2 SHANKS

ART. Z090

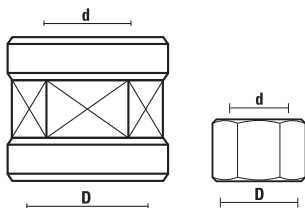

| RH rotation | LH rotation | D | d | Wrench |
|-------------|-------------|------------|-----------|--------|
| Z090.001.R | Z090.001.L | M33x3 | ∅20/14x1" | 38 |
| Z090.002.R | Z090.002.L | M33x3 | M30x1,5 | 38 |
| Z090.011.R | | 1"1/8"x7G8 | ∅20/14x1" | 38 |
| Z090.012.R | Z090.012.L | 1"1/8"x7G9 | M30x1,5 | 38 |

COLLET NUTS

ART. Z091

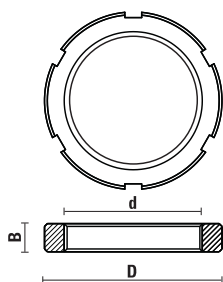

For Art. T118.953.R/T118.956.R/T118.959.R

| Item | D | B | d | Rotation |
|------------|----|----|----------|----------|
| Z091.902.R | 63 | 10 | M 50x1,5 | RH |

"NO-NOISE" COLLET NUTS

ART. Z091

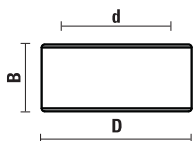

- Recommended when using router bits working at higher RPM
- Threaded nut with ground contours, remarkable reduction of noise

| Item | Type | D | B | d | Rot. |
|------------|-------------------|----|------|----------|------|
| Z091.501.R | DIN 6499 (ER 32) | 50 | 23 | M 40x1,5 | RH |
| Z091.505.R | DIN 6499 (ER 16) | 32 | 17,5 | M 22x1,5 | RH |
| Z091.522.R | DIN 6499 (EOC 25) | 60 | 30 | M 48x2 | RH |

COLLET NUTS

ART. Z091

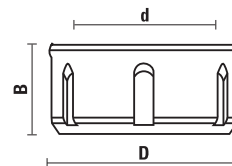

| Item | Type | D | B | d | Rot. |
|-----------------------|------------------------------|----|------|-----------|------|
| Z091.000.R | For spring collets Art. T117 | 40 | 20 | M 30x1,5 | RH |
| Z091.000.L | For spring collets Art. T117 | 40 | 20 | M 30x1,5 | LH |
| Z091.001.R | DIN 6499 (ER 32) | 50 | 23 | M 40x1,5 | RH |
| Z091.001.L | DIN 6499 (ER 32) | 50 | 23 | M 40x1,5 | LH |
| Z091.002.R | DIN 6499 (ER 40) | 63 | 25 | M 50x1,5 | RH |
| Z091.002.L | DIN 6499 (ER 40) | 63 | 25 | M 50x1,5 | LH |
| Z091.005.R NEW | For spring collets T133 | 50 | 23 | M 40x1,5 | RH |
| Z091.103.R | DIN 6499 (ER 25) | 42 | 20 | M 32x1,5 | RH |
| Z091.104.R | DIN 6499 (ER 20) | 35 | 19 | M 25x1,5 | RH |
| Z091.105.R | DIN 6499 (ER 16) | 32 | 17,5 | M 22x1,5 | RH |
| Z091.202.R | DIN 6388 (EOC25) | 60 | 30 | M 48x2 | RH |
| Z091.205.R | DIN 6388 (EOC12) | 35 | 28 | M 27x1,5 | RH |
| Z091.301.R | ETS 32 | 50 | 22 | M 40x1,5 | RH |
| Z091.302.R | ETS 40 | 63 | 25 | M 50x1,5 | RH |
| Z091.403.R | ER 25 Type mini | 35 | 20 | M 30x1 | RH |
| Z091.404.R | ER 20 Type mini | 28 | 19 | M 24x1 | RH |
| Z091.405.R | ER 16 Type mini | 22 | 18 | M 19x1 | RH |
| Z091.406.R | ER 11 Type mini | 16 | 12 | M 13x0,75 | RH |

COLLET NUTS WITH BALL BEARINGS

ART. Z091

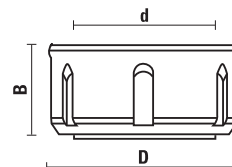

- The ball bearing clamping nut **improves the clamping precision** thanks to a **homogeneous clamping force**
- Easy and fast removal of the collet from the nut
- It can be used **both for right-hand and left-hand rotation**

| Item | Type | D | B | d | Rot. |
|------------|------------------|----|----|----------|-------|
| Z091.100.R | DIN 6499 (ER 25) | 42 | 20 | M 32x1,5 | RH/LH |
| Z091.101.R | DIN 6499 (ER 32) | 50 | 26 | M 40x1,5 | RH/LH |
| Z091.102.R | DIN 6499 (ER 40) | 63 | 29 | M 50x1,5 | RH/LH |
| Z091.203.R | DIN 6388 (EOC25) | 60 | 30 | M 48x2 | RH/LH |

CLAMPING NUT WITH ECCENTRIC RING

ART. Z091

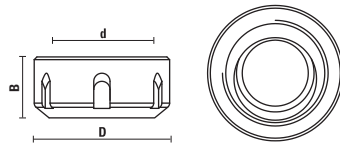

- To be used with our water-tight collets (Items T119/T123 NTS) at page 7.26 and stainless steel collet chucks at page 7.23 of our Catalog
 - Suitable when working with coolant

| Item | Type | D | B | d | Rot. |
|-----------------------|------------------|----|----|----------|------|
| Z091.051.R NEW | DIN 6499 (ER 32) | 50 | 23 | M 40x1,5 | RH |
| Z091.052.R NEW | DIN 6499 (ER 40) | 63 | 25 | M 50x1,5 | RH |

END CAPS

ART. Z092

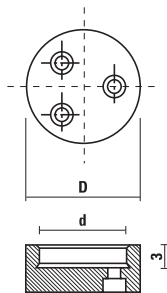

Hollow end cap (FF)

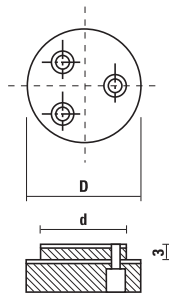

Extended end cap (FP)

Use on arbors Art. T128

| Item | d | D | Type |
|------------|--------------|----|------|
| Z092.001.R | 30 | 40 | FF |
| Z092.002.R | 30 | 40 | FP |
| Z092.003.R | 35 | 50 | FF |
| Z092.004.R | 35 | 50 | FP |
| Z092.005.R | 40 | 50 | FF |
| Z092.006.R | 40 | 50 | FP |
| Z092.007.R | 25,4 (1") | 50 | FF |
| Z092.008.R | 25,4 (1") | 50 | FP |
| Z092.009.R | 31,75 (1/4") | 50 | FF |
| Z092.010.R | 31,75 (1/4") | 50 | FP |

FIXING FLANGE FOR ART. T132.320.NS

ART. Z092

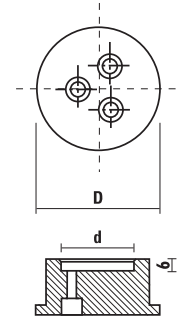

Hollow end cap (FF)

Use on arbors Art. T132.320.NS

| Item | d | D | Type |
|------------|----|----|------|
| Z092.050.R | 40 | 80 | FF |

REDUCTION RINGS FOR SAWBLADES

ART. ZA

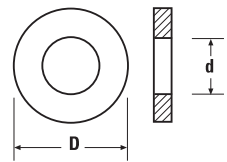

| Item | D | d |
|-------------|----|------|
| ZA000.02012 | 20 | 12,7 |
| ZA000.02013 | 20 | 13 |
| ZA000.02015 | 20 | 15 |
| ZA000.02016 | 20 | 16 |
| ZA000.03015 | 30 | 15 |
| ZA000.03016 | 30 | 16 |
| ZA000.03020 | 30 | 20 |
| ZA000.03025 | 30 | 25 |
| ZA000.03026 | 30 | 25,4 |
| ZA000.03028 | 30 | 28,6 |
| ZA000.03220 | 32 | 20 |
| ZA000.03230 | 32 | 30 |
| ZA000.03516 | 35 | 16 |
| ZA000.03520 | 35 | 20 |
| ZA000.03526 | 35 | 26 |
| ZA000.03530 | 35 | 30 |
| ZA000.03532 | 35 | 32 |
| ZA000.04030 | 40 | 30 |
| ZA000.04032 | 40 | 32 |
| ZA000.04035 | 40 | 35 |

REDUCTION RINGS FOR CUTTERHEADS

ART. ZA010

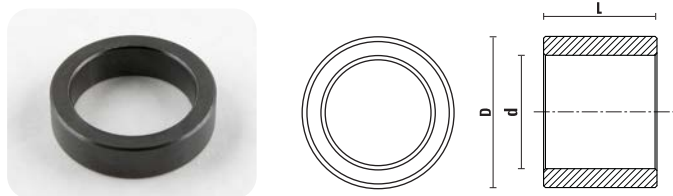

Tolerance:

D= 0/- 0,02
d= + 0,02/0
L= ± 0,02

| Item | D | d | L |
|--------------|----|----|----|
| ZA010.322020 | 32 | 20 | 20 |
| ZA010.353005 | 35 | 30 | 5 |
| ZA010.353010 | 35 | 30 | 10 |
| ZA010.353015 | 35 | 30 | 15 |
| ZA010.353020 | 35 | 30 | 20 |
| ZA010.353025 | 35 | 30 | 25 |
| ZA010.353030 | 35 | 30 | 30 |
| ZA010.353035 | 35 | 30 | 35 |
| ZA010.353040 | 35 | 30 | 40 |
| ZA010.403005 | 40 | 30 | 5 |
| ZA010.403010 | 40 | 30 | 10 |
| ZA010.403015 | 40 | 30 | 15 |
| ZA010.403020 | 40 | 30 | 20 |
| ZA010.403025 | 40 | 30 | 25 |
| ZA010.403030 | 40 | 30 | 30 |
| ZA010.403035 | 40 | 30 | 35 |
| ZA010.403040 | 40 | 30 | 40 |
| ZA010.403505 | 40 | 35 | 5 |
| ZA010.403510 | 40 | 35 | 10 |
| ZA010.403515 | 40 | 35 | 15 |
| ZA010.403520 | 40 | 35 | 20 |
| ZA010.403525 | 40 | 35 | 25 |
| ZA010.403530 | 40 | 35 | 30 |
| ZA010.403535 | 40 | 35 | 35 |
| ZA010.403540 | 40 | 35 | 40 |

REDUCING BUSHES

ART. ZA011



Tolerance:

D= 0/- 0,02
d= + 0,02/0

| Item | D | d | D2 |
|-------------|----|----|----|
| ZA011.03530 | 35 | 30 | 55 |
| ZA011.04030 | 40 | 30 | 60 |
| ZA011.04035 | 40 | 35 | 55 |
| ZA011.05030 | 50 | 30 | 70 |
| ZA011.05035 | 50 | 35 | 70 |
| ZA011.05040 | 50 | 40 | 70 |

visit our website

www.sistemiklein.com



SPACERS

ART. YD300 - YD350 - YD400 - YD500 - YD600

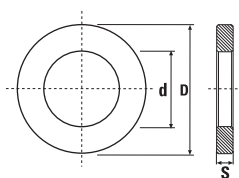

- For arbors Art. T128 - Art. T130 - Art. T131 - Art. T132
- Burnished
- Spacer rings fine-blanking processed for thickness 0,1÷1 mm (tolerance $\pm 0,02$)
- Spacer rings grinded on two sides for thickness 2÷50 mm (tolerance $\pm 0,01$)

| Item | D | d | S |
|-----------|----|----|-----|
| YD300.001 | 30 | 50 | 0,1 |
| YD300.002 | 30 | 50 | 0,2 |
| YD300.005 | 30 | 50 | 0,5 |
| YD300.010 | 30 | 50 | 1 |
| YD300.020 | 30 | 50 | 2 |
| YD300.030 | 30 | 50 | 3 |
| YD300.040 | 30 | 50 | 4 |
| YD300.050 | 30 | 50 | 5 |
| YD300.060 | 30 | 50 | 6 |
| YD300.080 | 30 | 50 | 8 |
| YD300.100 | 30 | 50 | 10 |
| YD300.120 | 30 | 50 | 12 |
| YD300.150 | 30 | 50 | 15 |
| YD300.200 | 30 | 50 | 20 |
| YD300.250 | 30 | 50 | 25 |
| YD300.300 | 30 | 50 | 30 |
| YD300.400 | 30 | 50 | 40 |
| YD300.500 | 30 | 50 | 50 |
| YD350.001 | 35 | 55 | 0,1 |
| YD350.002 | 35 | 55 | 0,2 |
| YD350.005 | 35 | 55 | 0,5 |
| YD350.010 | 35 | 55 | 1 |
| YD350.020 | 35 | 55 | 2 |
| YD350.030 | 35 | 55 | 3 |
| YD350.040 | 35 | 55 | 4 |
| YD350.050 | 35 | 55 | 5 |
| YD350.060 | 35 | 55 | 6 |
| YD350.080 | 35 | 55 | 8 |
| YD350.100 | 35 | 55 | 10 |
| YD350.120 | 35 | 55 | 12 |
| YD350.150 | 35 | 55 | 15 |
| YD350.200 | 35 | 55 | 20 |
| YD350.250 | 35 | 55 | 25 |
| YD350.300 | 35 | 55 | 30 |
| YD350.400 | 35 | 55 | 40 |
| YD350.500 | 35 | 55 | 50 |

| Item | D | D1 | S |
|-----------|----|----|-----|
| YD400.001 | 40 | 60 | 0,1 |
| YD400.002 | 40 | 60 | 0,2 |
| YD400.005 | 40 | 60 | 0,5 |
| YD400.010 | 40 | 60 | 1 |
| YD400.020 | 40 | 60 | 2 |
| YD400.030 | 40 | 60 | 3 |
| YD400.040 | 40 | 60 | 4 |
| YD400.050 | 40 | 60 | 5 |
| YD400.060 | 40 | 60 | 6 |
| YD400.080 | 40 | 60 | 8 |
| YD400.100 | 40 | 60 | 10 |
| YD400.120 | 40 | 60 | 12 |
| YD400.150 | 40 | 60 | 15 |
| YD400.200 | 40 | 60 | 20 |
| YD400.250 | 40 | 60 | 25 |
| YD400.300 | 40 | 60 | 30 |
| YD400.400 | 40 | 60 | 40 |
| YD400.500 | 40 | 60 | 50 |
| YD500.001 | 50 | 70 | 0,1 |
| YD500.002 | 50 | 70 | 0,2 |
| YD500.005 | 50 | 70 | 0,5 |
| YD500.010 | 50 | 70 | 1 |
| YD500.020 | 50 | 70 | 2 |
| YD500.030 | 50 | 70 | 3 |
| YD500.040 | 50 | 70 | 4 |
| YD500.050 | 50 | 70 | 5 |
| YD500.060 | 50 | 70 | 6 |
| YD500.080 | 50 | 70 | 8 |
| YD500.100 | 50 | 70 | 10 |
| YD500.120 | 50 | 70 | 12 |
| YD500.150 | 50 | 70 | 15 |
| YD500.200 | 50 | 70 | 20 |
| YD500.250 | 50 | 70 | 25 |
| YD500.300 | 50 | 70 | 30 |
| YD500.400 | 50 | 70 | 40 |
| YD500.500 | 50 | 70 | 50 |
| YD600.001 | 60 | 80 | 0,1 |
| YD600.002 | 60 | 80 | 0,2 |
| YD600.005 | 60 | 80 | 0,5 |
| YD600.010 | 60 | 80 | 1 |
| YD600.020 | 60 | 80 | 2 |
| YD600.030 | 60 | 80 | 3 |
| YD600.040 | 60 | 80 | 4 |
| YD600.050 | 60 | 80 | 5 |
| YD600.060 | 60 | 80 | 6 |
| YD600.080 | 60 | 80 | 8 |
| YD600.100 | 60 | 80 | 10 |
| YD600.120 | 60 | 80 | 12 |
| YD600.150 | 60 | 80 | 15 |
| YD600.200 | 60 | 80 | 20 |
| YD600.250 | 60 | 80 | 25 |
| YD600.300 | 60 | 80 | 30 |
| YD600.400 | 60 | 80 | 40 |
| YD600.500 | 60 | 80 | 50 |



SPACERS SET

ART. YD300 - YD350 - YD400 - YD500 - YD600

| Item | D | D1 |
|-----------|----|----|
| YD300.990 | 30 | 50 |
| YD350.990 | 35 | 55 |
| YD400.990 | 40 | 60 |
| YD500.990 | 50 | 70 |
| YD600.990 | 60 | 80 |

Complete with:

- nr. 4 sp. 2 mm - nr. 3 sp. 4 mm - nr. 2 sp. 5 mm
- nr. 2 sp. 10 mm - nr. 1 sp. 20 mm - nr. 1 sp. 30 mm

Reversible knives and knives for planers



11



HW STANDARD REVERSIBLE KNIVES
Page 11.04



HW STANDARD REVERSIBLE KNIVES
Page 11.04

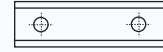

HW STANDARD REVERSIBLE KNIVES
Page 11.04



HW STANDARD REVERSIBLE KNIVES
Page 11.05



HW STANDARD REVERSIBLE KNIVES
Page 11.05

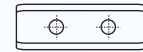

HW SPECIAL KNIVES
Page 11.05



HW SPECIAL KNIVES
Page 11.05



HW STANDARD REVERSIBLE KNIVES
Page 11.05



HW STANDARD REVERSIBLE KNIVES
Page 11.05



HW STANDARD REVERSIBLE KNIVES
Page 11.06



HW STANDARD REVERSIBLE KNIVES
Page 11.06

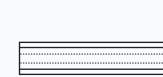

HW REVERSIBLE KNIVES "MINI"
Page 11.06



HW REVERSIBLE KNIVES "MINI"
Page 11.06

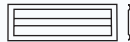

HW "VERSOFIX" KNIVES
Page 11.06



HW EDGE ROUNDING KNIVES
Page 11.06



HW STANDARD REVERSIBLE KNIVES
Page 11.08



HW STANDARD REVERSIBLE KNIVES
Page 11.08



HW STANDARD REVERSIBLE KNIVES
Page 11.08



HW STANDARD REVERSIBLE KNIVES
Page 11.08



HW STANDARD REVERSIBLE KNIVES
Page 11.08



HW SPECIAL KNIVES
Page 11.08

11



KleinDIA



HW SPECIAL KNIVES
Page 11.09

KleinDIA



HW STANDARD REVERSIBLE KNIVES
Page 11.09

KleinDIA



HW STANDARD REVERSIBLE KNIVES
Page 11.09

KleinDIA



HW STANDARD REVERSIBLE KNIVES
Page 11.09

KleinDIA



HW STANDARD REVERSIBLE KNIVES
Page 11.09

KleinDIA



HW REVERSIBLE KNIVES "MINI"
Page 11.09

KleinDIA



HW REVERSIBLE KNIVES "MINI"
Page 11.09



KleinDIA

HW EDGE ROUNDING KNIVES
Page 11.09



DP STANDARD REVERSIBLE KNIVES
Pag. 11.10

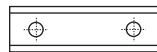

DP STANDARD REVERSIBLE KNIVES
Pag. 11.10

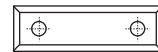

DP STANDARD REVERSIBLE KNIVES WITH 4 CUTTING EDGES
Pag. 11.10

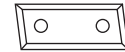

DP 5° INCLINED REVERSIBLE KNIVES WITH 4 CUTTING EDGES
Pag. 11.10



DP STANDARD REVERSIBLE KNIVES
Pag. 11.10



KNIVES FOR PORTABLE PLANERS
Page 11.11



HW TURNBLADE KNIVES FOR PORTABLE PLANERS
Page 11.11



LAMINATE CUTTERS
Page 11.12



MAGNETIC ALIGNERS FOR PLANER KNIVES
Page 11.12



PLANER KNIVES H=30/35 - HS=18% W
Page 11.12



PLANER KNIVES H=30/35 - HL=13% Cr
Page 11.13



PLANER KNIVES H=30/35 - HW=TCT
Page 11.13

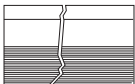

CORRUGATED BLANK KNIVES HS: 18% W
Page 11.14

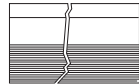

HW CORRUGATED BLANK KNIVES
Page 11.14



TURNBLADES "TERSA"
Page 11.15



TURNBLADES "CENTROLOCK"
Page 11.15



TURNBLADES "CENTROFIX QUICKFIX" - "CENTROSTAR"
Page 11.15



TURNBLADES "TERMINUS"
Page 11.16



TURNBLADES "BULLDOZER"
Page 11.16



TURNBLADES "ENSHIN"
Page 11.16



TURNBLADES "SINUS"
Page 11.16



TURNBLADES "VARIPLAN"
Page 11.17



TURNBLADES "BRUCK"
Page 11.17



TURNBLADES "ESTA"
Page 11.17

REVERSIBLE KNIVES

Grades and application chart

| Grades | Code USA | Code ISO | Cobalt | Density | Hardness | Softwood | Hardwood | Chipboard | MDF |
|--------------------|----------|----------|--------|--------------------|----------|----------|----------|-----------|-----|
| Fine grain | | | % | gr/cm ³ | HV10 | | | | |
| HC05 (HL05) | C3 | K10 | 4 | 15.15 | 1760 | X | X | XX | X |
| HC20 (HL15) | C2 | K20 | 6 | 14.95 | 1640 | XX | XX | X | - |
| HC27 (HL30) | C1 | K30 | 7,5 | 14.70 | 1470 | XX | XX | X | - |
| HC35 (HL40) | C1 | K30 | 9 | 14.60 | 1400 | XX | X | - | - |

Micro grain

| | | | | | | | | | |
|---------------------|----|-----|-----|-------|------|---|----|---|----|
| MG06 (DO50) | C4 | K01 | 3.3 | 15.20 | 2020 | - | - | X | XX |
| MG18 (HL20F) | C2 | K20 | 10 | 14.50 | 1680 | X | XX | - | - |

Ultra fine grain

| | | | | | | | | | |
|--------------|---|---|-----|-------|------|---|---|---|----|
| SMG02 | - | - | 2,5 | 15.25 | 2350 | - | - | X | XX |
|--------------|---|---|-----|-------|------|---|---|---|----|

Nano grain

| | | | | | | | | | |
|--------------|---|---|---|-------|------|---|---|---|----|
| UMG04 | - | - | 2 | 15.30 | 2550 | - | - | - | XX |
|--------------|---|---|---|-------|------|---|---|---|----|

Micro grain

| | | | | | | | | | |
|--------------|---|---|-----|-------|------|----|----|----|----|
| KCR08 | - | - | 3,2 | 15.20 | 1920 | XX | XX | XX | XX |
|--------------|---|---|-----|-------|------|----|----|----|----|

HC05 - HC20 - HC27 - HC35

This is the most widely used grade for indexable knives and profile blanks. Good performance on the whole range of materials used today in the woodworking industry. This grade sets the standard for performance and price

MG06

This micrograin carbide is harder than HC05 and can increase tool life by 50% when used on MDF.

MG18

By virtue of its micrograin structure MG18 is the optimum grade for 45° cutting edges. It creates a sharp, tough and wear resistant edge. This makes it ideal for machining hardwoods and brings the benefit of increased tool life.

SMG02

This is an even harder micrograin grade giving an increase of 100% in tool life compared with MG06. It allows longer production running on MDF.

UMG04

Tests have shown tool life increased by 3 times compared to SMG02 or 9 times the life of standard grades. For cutting very hard materials this is an economical alternative to DP tools with far less financial risk should breakage occur.

KCR08

Covers 99% of all applications (soft and hard wood, melamine, HDF, MDF).
More precise cutting edge execution due to submicrograin grade.
High corrosion resistance due to special power mix.

| Grain size definition | Average grain size range |
|-----------------------|--------------------------|
| Nano grain | < 0,2 µm |
| Ultrafine grain | 0,2 < 0,5 µm |
| Micrograin | 0,5 < 0,8 µm |
| Fine grain | 0,8 < 1,3 µm |
| Medium grain | 1,3 < 2,5 µm |
| Coarse grain | 2,5 < 6,0 µm |



HW STANDARD REVERSIBLE KNIVES

ART. Z055 - Z155 - Z255 - Z355 - Z455 - Z555

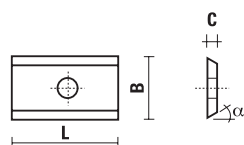

10 pcs. set

- 2 cutting edges
- 1 fixing hole

| Item | Grade | L | B | C | α |
|------------|-------|------|----|-----|----------|
| Z055.000.N | HC05 | 7,5 | 12 | 1,5 | 35° |
| Z055.012.N | HC05 | 9,6 | 12 | 1,5 | 35° |
| Z055.013.N | HC05 | 10,5 | 12 | 1,5 | 35° |
| Z055.002.N | HC05 | 15 | 12 | 1,5 | 35° |
| Z055.003.N | HC05 | 20 | 12 | 1,5 | 35° |
| Z055.014.N | HC05 | 25 | 12 | 1,5 | 35° |
| Z055.900.N | HC05 | 7,5 | 9 | 1,5 | 35° |
| Z055.901.N | HC05 | 12 | 9 | 1,5 | 35° |
| Z055.903.N | HC05 | 20 | 9 | 1,5 | 35° |
| Z155.000.N | MG06 | 7,5 | 12 | 1,5 | 35° |
| Z155.003.N | MG06 | 20 | 12 | 1,5 | 35° |
| Z255.003.N | SMG02 | 20 | 12 | 1,5 | 35° |
| Z355.003.N | UMG04 | 20 | 12 | 1,5 | 35° |
| Z455.000.N | MG18 | 7,5 | 12 | 1,5 | 45° |
| Z455.012.N | MG18 | 9,6 | 12 | 1,5 | 45° |
| Z455.002.N | MG18 | 15 | 12 | 1,5 | 45° |
| Z455.003.N | MG18 | 20 | 12 | 1,5 | 45° |
| Z555.000.N | KCR08 | 7,5 | 12 | 1,5 | 35° |
| Z555.012.N | KCR08 | 9,6 | 12 | 1,5 | 35° |
| Z555.002.N | KCR08 | 15 | 12 | 1,5 | 35° |
| Z555.003.N | KCR08 | 20 | 12 | 1,5 | 35° |
| Z555.014.N | KCR08 | 25 | 12 | 1,5 | 35° |

HW STANDARD REVERSIBLE KNIVES

ART. Z055 - Z355

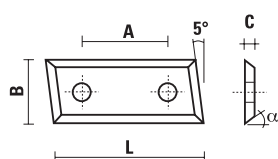

10 pcs. set

- 4 cutting edges
- 2 fixing holes
- 5° right

| Item | Grade | L | B | C | α | A |
|------------|-------|----|----|-----|----------|----|
| Z055.423.N | HC05 | 30 | 9 | 1,5 | 35° | 14 |
| Z055.424.N | HC05 | 40 | 9 | 1,5 | 35° | 26 |
| Z055.425.N | HC05 | 50 | 9 | 1,5 | 35° | 26 |
| Z055.430.N | HC05 | 30 | 12 | 1,5 | 35° | 14 |
| Z055.440.N | HC05 | 40 | 12 | 1,5 | 35° | 26 |
| Z055.450.N | HC05 | 50 | 12 | 1,5 | 35° | 26 |
| Z355.450.N | UMG04 | 50 | 12 | 1,5 | 35° | 26 |

HW STANDARD REVERSIBLE KNIVES

ART. Z055 - Z155 - Z255 - Z355 - Z455 - Z555

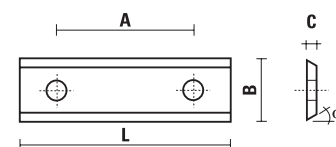

10 pcs. set

- 2 cutting edges
- 2 fixing holes

| Item | Grade | L | B | C | α | A |
|------------|-------|-----|----|-----|----------|----|
| Z055.015.N | HC05 | 25 | 12 | 1,5 | 35° | 14 |
| Z055.008.N | HC05 | 30 | 12 | 1,5 | 35° | 14 |
| Z055.009.N | HC05 | 40 | 12 | 1,5 | 35° | 26 |
| Z055.010.N | HC05 | 50 | 12 | 1,5 | 35° | 26 |
| Z055.011.N | HC05 | 60 | 12 | 1,5 | 35° | 26 |
| Z055.070.N | HC27 | 80 | 13 | 2,2 | 35° | 60 |
| Z055.071.N | HC27 | 100 | 13 | 2,2 | 35° | 60 |
| Z055.072.N | HC27 | 120 | 13 | 2,2 | 35° | 60 |
| Z055.073.N | HC27 | 130 | 13 | 2,2 | 35° | 60 |
| Z055.908.N | HC05 | 30 | 9 | 1,5 | 35° | 14 |
| Z055.909.N | HC05 | 40 | 9 | 1,5 | 35° | 26 |
| Z055.910.N | HC05 | 50 | 9 | 1,5 | 35° | 26 |
| Z155.008.N | MG06 | 30 | 12 | 1,5 | 35° | 14 |
| Z155.009.N | MG06 | 40 | 12 | 1,5 | 35° | 26 |
| Z155.010.N | MG06 | 50 | 12 | 1,5 | 35° | 26 |
| Z155.011.N | MG06 | 60 | 12 | 1,5 | 35° | 26 |
| Z255.008.N | SMG02 | 30 | 12 | 1,5 | 35° | 14 |
| Z255.009.N | SMG02 | 40 | 12 | 1,5 | 35° | 26 |
| Z255.010.N | SMG02 | 50 | 12 | 1,5 | 35° | 26 |
| Z255.011.N | SMG02 | 60 | 12 | 1,5 | 35° | 26 |
| Z355.008.N | UMG04 | 30 | 12 | 1,5 | 35° | 14 |
| Z355.010.N | UMG04 | 50 | 12 | 1,5 | 35° | 26 |
| Z455.008.N | MG18 | 30 | 12 | 1,5 | 45° | 14 |
| Z455.009.N | MG18 | 40 | 12 | 1,5 | 45° | 26 |
| Z455.010.N | MG18 | 50 | 12 | 1,5 | 45° | 26 |
| Z455.011.N | MG18 | 60 | 12 | 1,5 | 45° | 26 |
| Z455.980.N | MG18 | 80 | 13 | 2,2 | 45° | 60 |
| Z555.015.N | KCR08 | 25 | 12 | 1,5 | 35° | 14 |
| Z555.008.N | KCR08 | 30 | 12 | 1,5 | 35° | 14 |
| Z555.009.N | KCR08 | 40 | 12 | 1,5 | 35° | 26 |
| Z555.010.N | KCR08 | 50 | 12 | 1,5 | 35° | 26 |
| Z555.011.N | KCR08 | 60 | 12 | 1,5 | 35° | 26 |
| Z555.070.N | KCR08 | 80 | 13 | 2,2 | 35° | 60 |
| Z555.071.N | KCR08 | 100 | 13 | 2,2 | 35° | 60 |
| Z555.072.N | KCR08 | 120 | 13 | 2,2 | 35° | 60 |

HW STANDARD REVERSIBLE KNIVES

ART. Z055

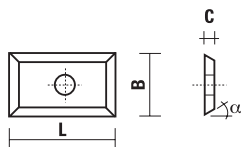

10 pcs. set

- 4 cutting edges
- 1 fixing hole

| Item | Grade | L | B | C | α |
|------------|-------|------|----|-----|----------|
| Z055.319.N | HC05 | 19,5 | 12 | 1,5 | 35° |
| Z055.320.N | HC05 | 19,5 | 9 | 1,5 | 35° |

HW STANDARD REVERSIBLE KNIVES

ART. Z055 - Z255 - Z355 - Z555

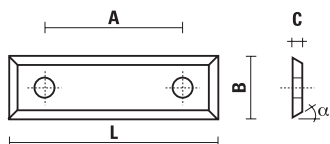

10 pcs. set

- 4 cutting edges
- 2 fixing holes

| Item | Grade | L | B | C | α | A |
|-----------------------|-------|------|----|-----|----------|----|
| Z055.110.N NEW | HC05 | 30 | 12 | 1,5 | 35° | 14 |
| Z055.329.N | HC05 | 29,5 | 12 | 1,5 | 35° | 14 |
| Z055.340.N | HC05 | 39,5 | 12 | 1,5 | 35° | 26 |
| Z055.349.N | HC05 | 49,5 | 12 | 1,5 | 35° | 26 |
| Z055.330.N | HC05 | 29,5 | 9 | 1,5 | 35° | 14 |
| Z055.341.N | HC05 | 39,5 | 9 | 1,5 | 35° | 26 |
| Z055.350.N | HC05 | 49,5 | 9 | 1,5 | 35° | 26 |
| Z255.329.N | SMG02 | 29,5 | 12 | 1,5 | 35° | 14 |
| Z255.340.N | SMG02 | 39,5 | 12 | 1,5 | 35° | 26 |
| Z255.349.N | SMG02 | 49,5 | 12 | 1,5 | 35° | 26 |
| Z355.349.N | UMG04 | 49,5 | 12 | 1,5 | 35° | 26 |
| Z555.329.N | KCR08 | 29,5 | 12 | 1,5 | 35° | 14 |
| Z555.340.N | KCR08 | 39,5 | 12 | 1,5 | 35° | 26 |
| Z555.350.N | KCR08 | 49,5 | 12 | 1,5 | 35° | 26 |

HW SPECIAL KNIVES

ART. Z055

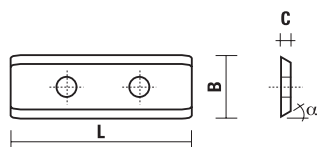

10 pcs. set

- 2 cutting edges
- 2 fixing holes

| Item | Grade | L | B | C | α |
|------------|-------|----|----|-----|----------|
| Z055.033.N | HC05 | 30 | 12 | 1,5 | 35° |
| Z055.035.N | HC05 | 50 | 12 | 1,5 | 35° |

HW SPECIAL KNIVES

ART. Z055

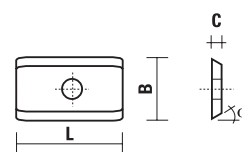

10 pcs. set

- 2 cutting edges
- 1 fixing hole

| Item | Grade | L | B | C | α |
|------------|-------|----|----|-----|----------|
| Z055.032.N | HC05 | 20 | 12 | 1,5 | 35° |

HW STANDARD REVERSIBLE KNIVES

ART. Z055 - Z155 - Z255 - Z455 - Z555

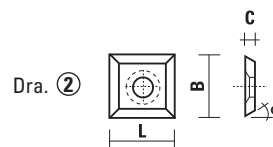
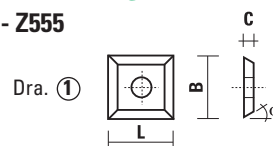
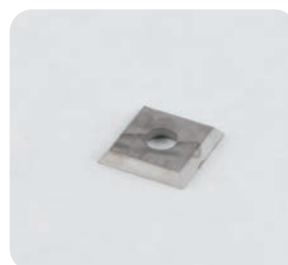

- 4 cutting edges
- 1 fixing hole

10 pcs. set

| Item | Grade | Drawing | L | B | C | α |
|-----------------------|-------|---------|------|------|-----|----------|
| Z055.016.N | HC05 | 1 | 10,5 | 10,5 | 1,5 | 35° |
| Z055.001.N | HC05 | 1 | 12 | 12 | 1,5 | 35° |
| Z055.006.N | HC35 | 2 | 14 | 14 | 1,2 | 30° |
| Z055.007.N | HC35 | 2 | 14 | 14 | 2 | 30° |
| Z055.107.N NEW | HC35 | 2 R=2 | 14 | 14 | 2 | 30° |
| Z155.001.N | MG06 | 1 | 12 | 12 | 1,5 | 35° |
| Z155.007.N | MG06 | 2 | 14 | 14 | 2 | 30° |
| Z255.001.N | SMG02 | 1 | 12 | 12 | 1,5 | 35° |
| Z255.007.N | SMG02 | 2 | 14 | 14 | 2 | 30° |
| Z455.001.N | MG18 | 1 | 12 | 12 | 1,5 | 45° |
| Z455.007.N | MG18 | 2 | 14 | 14 | 2 | 45° |
| Z555.001.N | KCR08 | 1 | 12 | 12 | 1,5 | 35° |
| Z555.007.N | KCR08 | 2 | 14 | 14 | 2 | 30° |

HW STANDARD REVERSIBLE KNIVES

ART. Z055

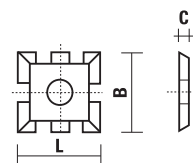

10 pcs. set

- 4 cutting edges
- 1 fixing hole

| Item | Grade | L | B | C |
|------------|-------|----|----|---|
| Z055.019.N | HC27 | 15 | 15 | 2 |

HW STANDARD REVERSIBLE KNIVES

ART. Z055

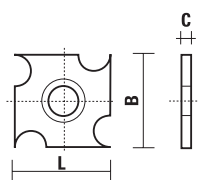

10 pcs. set

4 cutting edges

| Item | Grade | L | B | C |
|------------|-------|----|----|------|
| Z055.020.N | HC20 | 18 | 18 | 1,95 |
| Z055.021.N | HC20 | 18 | 18 | 2,45 |
| Z055.022.N | HC20 | 18 | 18 | 2,95 |

HW STANDARD REVERSIBLE KNIVES

ART. Z455

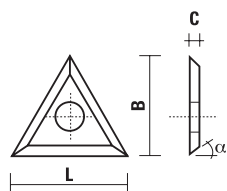

10 pcs. set

3 cutting edges

| Item | Grade | L | B | C | α |
|------------|-------|----|----|---|----------|
| Z455.030.N | MG18 | 22 | 19 | 2 | 30° |

HW REVERSIBLE KNIVES "MINI"

ART. Z055

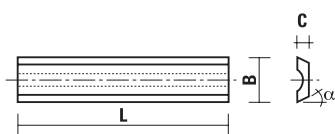

10 pcs. set

- 2 cutting edges
- Front groove

| Item | Grade | L | B | C | α |
|------------|-------|----|-----|-----|----------|
| Z055.080.N | HC05 | 12 | 5,5 | 1,1 | 35° |
| Z055.081.N | HC05 | 20 | 5,5 | 1,1 | 35° |
| Z055.082.N | HC05 | 30 | 5,5 | 1,1 | 35° |
| Z055.083.N | HC05 | 40 | 5,5 | 1,1 | 35° |
| Z055.084.N | HC05 | 50 | 5,5 | 1,1 | 35° |

HW REVERSIBLE KNIVES "MINI"

ART. Z055

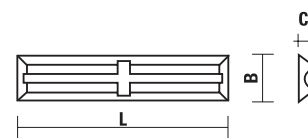

10 pcs. set

- 4 cutting edges
- Back groove with safety notch

| Item | Grade | L | B | C | α |
|------------|-------|----|-----|-----|----------|
| Z055.085.N | HC05 | 20 | 4,1 | 1,1 | 35° |
| Z055.086.N | HC05 | 20 | 5,5 | 1,1 | 35° |
| Z055.087.N | HC05 | 25 | 5,5 | 1,1 | 35° |
| Z055.088.N | HC05 | 30 | 5,5 | 1,1 | 35° |
| Z055.089.N | HC05 | 50 | 5,5 | 1,1 | 35° |

HW "VERSOFIX" KNIVES

ART. Z055

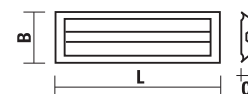

10 pcs. set

- With "Kawedur" coating
- 4 cutting edges
- Spare parts for W120÷W127 and W138

| Item | L | B | C |
|------------|----|-----|-----|
| Z055.220.N | 20 | 5,5 | 1,1 |
| Z055.221.N | 20 | 10 | 1,5 |
| Z055.230.N | 30 | 6,5 | 1,1 |
| Z055.231.N | 30 | 10 | 1,5 |
| Z055.250.N | 50 | 10 | 1,5 |

HW EDGE ROUNDING KNIVES

ART. Z060

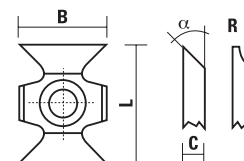

10 pcs. set

| Item | Grade | L | B | C | α/R |
|------------|-------|----|----|---|------------|
| Z060.000.N | HC20 | 22 | 16 | 5 | 45° |
| Z060.015.N | HC20 | 22 | 16 | 5 | R=1,5 |
| Z060.020.N | HC20 | 22 | 16 | 5 | R=2 |
| Z060.030.N | HC20 | 22 | 16 | 5 | R=3 |
| Z060.050.N | HC20 | 22 | 16 | 5 | R=5 |

KleinDIA

A surface treatment developed for large-scale production

KleinDIA is a DLC (**Diamond-like Carbon**) anti-friction coating which allows to solve problems of tool abrasion, chip evacuation and chemical attack.

A layer of approx. 1 micron is laid on the tool surface at low temperature, thus not altering the properties of the router bit or knife.

Its high hardness is granted by both Sp2 (**Graphite**) and Sp3 (**Diamond**) carbon hybridisation.

Our several tests confirmed remarkable results on both panel working and solid wood processing.

Working plastic and aluminium without coolant is also possible thanks to a very low friction coefficient.

TECHNICAL FEATURES:

- **High hardness** Hv0,025: 2500-3100
- **Higher wear resistance** (longer working time)
- **Low frictional coefficient** (lowered working temperature)
- **Very low sticking coefficient** (Better chips evacuation)
- **Thickness:** approx. 1 micron
- **Colour:** bright black



KleinDIA is the most advantageous coating, ensuring:

- **Production increase**
- **Better finishing**
- **Less maintenance**

The surface coating **KleinDIA** can be applied on many other products giving extraordinary results depending on the type of material processed. Excellent results can be achieved processing solid wood, plywood, Plexiglas, plastic and graphitic materials.

HERE ARE SOME OF THE ITEMS WHICH ARE SUITABLE TO BE COATED WITH **KleinDIA**:

Solid carbide straight router bits
ART. A101/2/3 - C101/2/3 - C190 - D101/2



Page 1.07, 1.23, 2.05

Solid carbide spiral router bits
ART. T141/2/3 - T151/2/3 - T157/8/9



Page from 7.46 to 7.52, 7.54

Solid carbide dowel drills
ART. L116 - L117



Page 5.11

Solid carbide through-hole boring bits
ART. L134 - L135



Pag. 5.17

HW reversible knives
ART. ZB



Pag. 11.10

HS planer knives
ART. ZC 30 - ZC 35



Pag. 11.11, 11.12, 11.13



HW STANDARD REVERSIBLE KNIVES

ART. Z055.KD

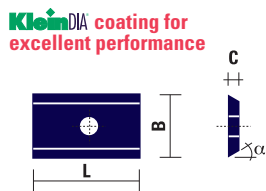
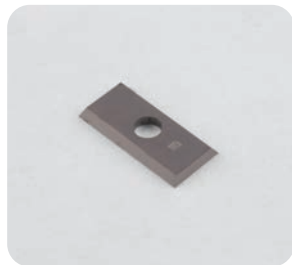

10 pcs. set

- 2 cutting edges
- 1 fixing hole

| Item | Grade | L | B | C | α |
|--------------|-------|------|----|-----|----------|
| Z055.000.NKD | HC05 | 7,5 | 12 | 1,5 | 35° |
| Z055.012.NKD | HC05 | 9,6 | 12 | 1,5 | 35° |
| Z055.013.NKD | HC05 | 10,5 | 12 | 1,5 | 35° |
| Z055.002.NKD | HC05 | 15 | 12 | 1,5 | 35° |
| Z055.003.NKD | HC05 | 20 | 12 | 1,5 | 35° |
| Z055.014.NKD | HC05 | 25 | 12 | 1,5 | 35° |
| Z055.900.NKD | HC05 | 7,5 | 9 | 1,5 | 35° |
| Z055.901.NKD | HC05 | 12 | 9 | 1,5 | 35° |
| Z055.903.NKD | HC05 | 20 | 9 | 1,5 | 35° |

HW STANDARD REVERSIBLE KNIVES

ART. Z055.KD

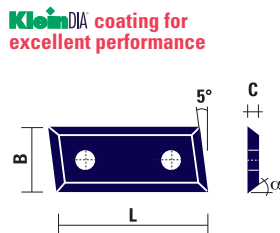

10 pcs. set

- 4 cutting edges
- 2 fixing holes
- 5° right

| Item | Grade | L | B | C | α |
|--------------|-------|----|----|-----|----------|
| Z055.423.NKD | HC05 | 30 | 9 | 1,5 | 35° |
| Z055.424.NKD | HC05 | 40 | 9 | 1,5 | 35° |
| Z055.425.NKD | HC05 | 50 | 9 | 1,5 | 35° |
| Z055.430.NKD | HC05 | 30 | 12 | 1,5 | 35° |
| Z055.440.NKD | HC05 | 40 | 12 | 1,5 | 35° |
| Z055.450.NKD | HC05 | 50 | 12 | 1,5 | 35° |

HW STANDARD REVERSIBLE KNIVES

ART. Z055.KD

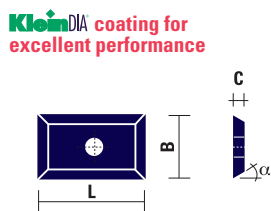
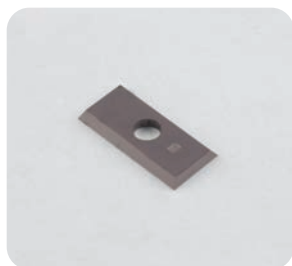

10 pcs. set

- 4 cutting edges
- 1 fixing hole

| Item | Grade | L | B | C | α |
|--------------|-------|------|----|-----|----------|
| Z055.319.NKD | HC05 | 19,5 | 12 | 1,5 | 35° |
| Z055.320.NKD | HC05 | 19,5 | 9 | 1,5 | 35° |

HW STANDARD REVERSIBLE KNIVES

ART. Z055.KD

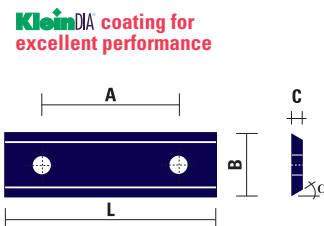

10 pcs. set

- 2 cutting edges
- 2 fixing holes

| Item | Grade | L | B | C | α | A |
|--------------|-------|----|----|-----|----------|----|
| Z055.015.NKD | HC05 | 25 | 12 | 1,5 | 35° | 14 |
| Z055.008.NKD | HC05 | 30 | 12 | 1,5 | 35° | 14 |
| Z055.009.NKD | HC05 | 40 | 12 | 1,5 | 35° | 26 |
| Z055.010.NKD | HC05 | 50 | 12 | 1,5 | 35° | 26 |
| Z055.011.NKD | HC05 | 60 | 12 | 1,5 | 35° | 26 |
| Z055.908.NKD | HC05 | 30 | 9 | 1,5 | 35° | 14 |
| Z055.909.NKD | HC05 | 40 | 9 | 1,5 | 35° | 26 |
| Z055.910.NKD | HC05 | 50 | 9 | 1,5 | 35° | 26 |

HW STANDARD REVERSIBLE KNIVES

ART. Z055.KD

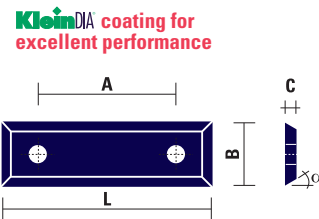

10 pcs. set

- 4 cutting edges
- 2 fixing holes

| Item | Grade | L | B | C | α | A |
|--------------|-------|------|----|-----|----------|----|
| Z055.329.NKD | HC05 | 29,5 | 12 | 1,5 | 35° | 14 |
| Z055.340.NKD | HC05 | 39,5 | 12 | 1,5 | 35° | 26 |
| Z055.349.NKD | HC05 | 49,5 | 12 | 1,5 | 35° | 26 |
| Z055.330.NKD | HC05 | 29,5 | 9 | 1,5 | 35° | 14 |
| Z055.341.NKD | HC05 | 39,5 | 9 | 1,5 | 35° | 26 |
| Z055.350.NKD | HC05 | 49,5 | 9 | 1,5 | 35° | 26 |

HW SPECIAL KNIVES

ART. Z055.KD

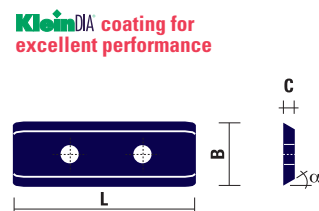

10 pcs. set

- 2 cutting edges
- 2 fixing holes

| Item | Grade | L | B | C | α |
|--------------|-------|----|----|-----|----------|
| Z055.033.NKD | HC05 | 30 | 12 | 1,5 | 35° |
| Z055.035.NKD | HC05 | 50 | 12 | 1,5 | 35° |

HW SPECIAL KNIVES

ART. Z055.KD

KleinDIA coating for excellent performance

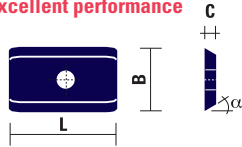

- 2 cutting edges
- 1 fixing hole

10 pcs. set

| Item | Grade | L | B | C | α |
|--------------|-------|----|----|-----|----------|
| Z055.032.NKD | HC05 | 20 | 12 | 1,5 | 35° |

HW STANDARD REVERSIBLE KNIVES

ART. Z055.KD

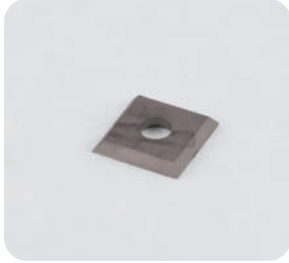

KleinDIA coating for excellent performance

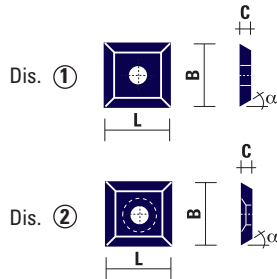

- 4 cutting edges
- 1 fixing hole

10 pcs. set

| Item | Grade | Drawing | L | B | C | α |
|--------------|-------|---------|------|------|-----|----------|
| Z055.016.NKD | HC05 | 1 | 10,5 | 10,5 | 1,5 | 35° |
| Z055.001.NKD | HC05 | 1 | 12 | 12 | 1,5 | 35° |
| Z055.006.NKD | HC35 | 2 | 14 | 14 | 1,2 | 30° |
| Z055.007.NKD | HC35 | 2 | 14 | 14 | 2 | 30° |

HW STANDARD REVERSIBLE KNIVES

ART. Z055.KD

KleinDIA coating for excellent performance

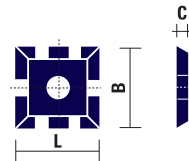

- 4 cutting edges
- 1 fixing hole

10 pcs. set

| Item | Grade | L | B | C |
|--------------|-------|----|----|---|
| Z055.019.NKD | HC27 | 15 | 15 | 2 |

HW STANDARD REVERSIBLE KNIVES

ART. Z055.KD

KleinDIA coating for excellent performance

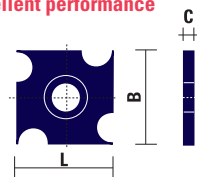

10 pcs. set

4 cutting edges

| Item | Grade | L | B | C |
|--------------|-------|----|----|------|
| Z055.020.NKD | HC20 | 18 | 18 | 1,95 |
| Z055.021.NKD | HC20 | 18 | 18 | 2,45 |
| Z055.022.NKD | HC20 | 18 | 18 | 2,95 |

HW STANDARD REVERSIBLE KNIVES

ART. Z455.KD

KleinDIA coating for excellent performance

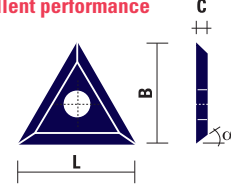
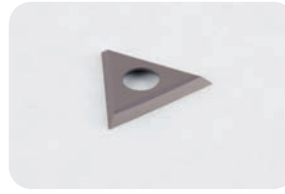

3 cutting edges

10 pcs. set

| Item | Grade | L | B | C | α |
|--------------|-------|----|----|---|----------|
| Z455.030.NKD | MG18 | 22 | 19 | 2 | 30° |

HW REVERSIBLE KNIVES "MINI"

ART. Z055.KD

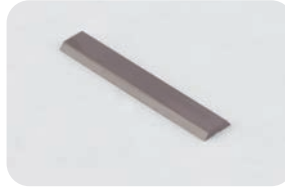

KleinDIA coating for excellent performance



- 2 cutting edges
- Front groove

10 pcs. set

| Item | Grade | L | B | C | α |
|--------------|-------|----|-----|-----|----------|
| Z055.080.NKD | HC05 | 12 | 5,5 | 1,1 | 35° |
| Z055.081.NKD | HC05 | 20 | 5,5 | 1,1 | 35° |
| Z055.082.NKD | HC05 | 30 | 5,5 | 1,1 | 35° |
| Z055.083.NKD | HC05 | 40 | 5,5 | 1,1 | 35° |
| Z055.084.NKD | HC05 | 50 | 5,5 | 1,1 | 35° |

HW REVERSIBLE KNIVES "MINI"

ART. Z055.KD



KleinDIA coating for excellent performance

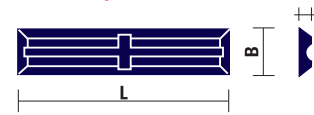

- 4 cutting edges
- Back groove with safety notch

10 pcs. set

| Item | Grade | L | B | C | α |
|--------------|-------|----|-----|-----|----------|
| Z055.085.NKD | HC05 | 20 | 4,1 | 1,1 | 35° |
| Z055.086.NKD | HC05 | 20 | 5,5 | 1,1 | 35° |
| Z055.087.NKD | HC05 | 25 | 5,5 | 1,1 | 35° |
| Z055.088.NKD | HC05 | 30 | 5,5 | 1,1 | 35° |
| Z055.089.NKD | HC05 | 50 | 5,5 | 1,1 | 35° |

HW EDGE ROUNDING KNIVES

ART. Z060.KD

KleinDIA coating for excellent performance

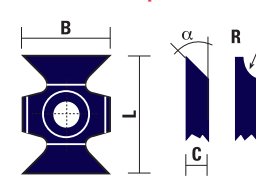
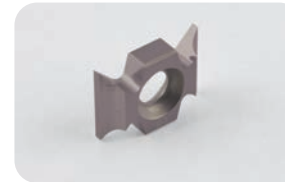

10 pcs. set

| Item | Grade | L | B | C | α/R |
|--------------|-------|----|----|---|------------|
| Z060.000.NKD | HC20 | 22 | 16 | 5 | 45° |
| Z060.015.NKD | HC20 | 22 | 16 | 5 | R=1,5 |
| Z060.020.NKD | HC20 | 22 | 16 | 5 | R=2 |
| Z060.030.NKD | HC20 | 22 | 16 | 5 | R=3 |
| Z060.050.NKD | HC20 | 22 | 16 | 5 | R=5 |

DP STANDARD REVERSIBLE KNIVES

ART. XZ055

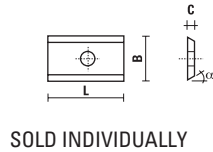

- These knives replace perfectly the HW standard knives
- **2 cutting edges**
- Lifetime up to 35/50 times longer compared to the HC05 (HW) knives
- 1 fixing hole
- Regrindable knives
- **CAUTION:** when sharpening a multicutter bit make sure that all the knives are mounted at the same height

| Item | L | B | C | α |
|------------------------|-----|----|-----|----------|
| XZ055.000.N NEW | 7,5 | 12 | 1,5 | 35° |
| XZ055.012.N NEW | 9,6 | 12 | 1,5 | 35° |
| XZ055.002.N NEW | 15 | 12 | 1,5 | 35° |
| XZ055.003.N NEW | 20 | 12 | 1,5 | 35° |
| XZ055.014.N NEW | 25 | 12 | 1,5 | 35° |

DP STANDARD REVERSIBLE KNIVES

ART. XZ055

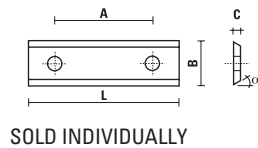

- These knives replace perfectly the HW standard knives
- **2 cutting edges**
- Lifetime up to 35/50 times longer compared to the HC05 (HW) knives
- 2 fixing hole
- Regrindable knives
- **CAUTION:** when sharpening a multicutter bit make sure that all the knives are mounted at the same height

| Item | L | B | C | α | A |
|------------------------|----|----|-----|----------|----|
| XZ055.008.N NEW | 30 | 12 | 1,5 | 35° | 14 |
| XZ055.009.N NEW | 40 | 12 | 1,5 | 35° | 26 |
| XZ055.010.N NEW | 50 | 12 | 1,5 | 35° | 26 |
| XZ055.011.N NEW | 60 | 12 | 1,5 | 35° | 26 |

DP STANDARD REVERSIBLE KNIVES WITH 4 CUTTING EDGES

ART. XZ055

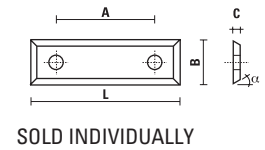

- These knives replace perfectly the HW standard knives
- **4 cutting edges**
- Lifetime up to 35/50 times longer compared to the HC05 (HW) knives
- 2 fixing hole
- Regrindable knives
- **CAUTION:** when sharpening a multicutter bit make sure that all the knives are mounted at the same height

| Item | L | B | C | α | A |
|------------------------|------|----|-----|----------|----|
| XZ055.329.N NEW | 29,5 | 12 | 1,5 | 35° | 14 |
| XZ055.340.N NEW | 39,5 | 12 | 1,5 | 35° | 26 |
| XZ055.349.N NEW | 49,5 | 12 | 1,5 | 35° | 26 |

DP 5° INCLINED REVERSIBLE KNIVES WITH 4 CUTTING EDGES

ART. XZ055

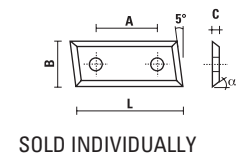

- These knives replace perfectly the HW standard knives
- **4 cutting edges**
- Lifetime up to 35/50 times longer compared to the HC05 (HW) knives
- **5° right-hand inclination**
- 2 fixing hole
- Regrindable knives
- **CAUTION:** when sharpening a multicutter bit make sure that all the knives are mounted at the same height

| Item | L | B | C | α | A |
|------------------------|------|----|-----|----------|----|
| XZ055.430.N NEW | 29,5 | 12 | 1,5 | 35° | 14 |
| XZ055.440.N NEW | 39,5 | 12 | 1,5 | 35° | 26 |
| XZ055.450.N NEW | 49,5 | 12 | 1,5 | 35° | 26 |

DP STANDARD REVERSIBLE KNIVES

ART. XZ055

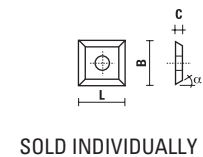
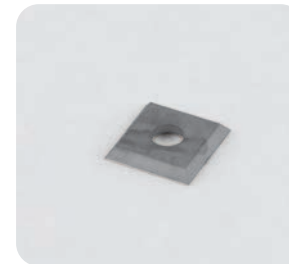

- **4 cutting edges**
- Lifetime up to 35/50 times longer compared to the HC05 (HW) knives
- 1 fixing hole
- Regrindable knives
- **CAUTION:** when sharpening a multicutter bit make sure that all the knives are mounted at the same height

| Item | L | B | C | α |
|------------------------|----|----|-----|----------|
| XZ055.001.N NEW | 12 | 12 | 1,5 | 35° |

KNIVES FOR PORTABLE PLANERS

| Item | L | H | S | Machine model |
|-------------|-----|----|---|---------------|
| *Z081.010.N | 82 | 28 | 3 | HS Hitachi |
| *Z081.021.N | 80 | 27 | 3 | HS Elu |
| *Z080.040.N | 80 | 29 | 3 | HW Star |
| *Z081.040.N | 80 | 29 | 3 | HS Star |
| Z080.050.N | 82 | 29 | 3 | HW Makita |
| Z081.050.N | 82 | 29 | 3 | HS Makita |
| Z080.052.N | 110 | 29 | 3 | HW Makita |
| Z081.052.N | 110 | 29 | 3 | HS Makita |
| Z080.051.N | 155 | 33 | 3 | HW Makita |
| Z081.051.N | 155 | 33 | 3 | HS Makita |
| Z080.053.N | 170 | 35 | 3 | HW Makita |
| Z081.053.N | 170 | 35 | 3 | HS Makita |
| Z080.080.N | 260 | 21 | 3 | HW Dewalt |
| Z081.080.N | 260 | 21 | 3 | HS Dewalt |

* Selling out



CONTACT US
 (+39) 0721 28950
 info@sistemiklein.com

HW TURNBLADE KNIVES FOR PORTABLE PLANERS

ART. ZB



10 pcs. set

| Item | Dimension | Producer | Machine model |
|--------|--------------|----------------|---|
| ZB0755 | 75,5X5,5X1,1 | AEG | HTH75 |
| | | BLACK & DECKER | DN75, 750SR, 600K |
| | | BOSCH | 0590, 1590, 1591, P400 |
| | | FESTO | REP75 |
| | | HAFFNER | FH222 |
| | | HOLZ-HER | 2223, 2286, 2320 |
| | | KRESS | JET-STAR 6701, 6702 |
| | | MAFELL | HU75 |
| | | METABO | 6375 |
| | | SCHEER | MH75/3, MH80 |
| | | SKIL | 98H |
| ZB0805 | 80,5X5,9X1,2 | ELU | MFF40, MFF80, PF161, MFF81, MFF81EK |
| ZB0820 | 82X5,5X1,1 | AEG | EH450, EH825, EH700, EH700R |
| | | | EH822, H500, H750 |
| | | BLACK & DECKER | DN710, DN712, DN730 |
| | | BOSCH | PH0282, PH0382 |
| | | CASALS | CE82 |
| | | FEIN | HS2151 |
| | | FELISATTI | TP282 |
| | | HAFFNER | FH224 |
| | | HITACHI | F20, F20A, P20V, P20SA, FP20A |
| | | HOLZ-HER | 2223, 2321 |
| | | LEGNA | R82, G82 |
| | | MAFELL | MHU82 |
| | | MAKITA | 1001, 1100, 1900, 1901, 1125B, 1923B, 1923H, 1923HO |
| | | METABO | 0882, 0883, E0983, 3360, 4382, 8382 |
| | | PERLES | HHB82B |
| | | PEUGEOT | BRA3-82, BR82, RA400, 82RAC, RA1082CA |
| | | SKIL | 92H, 94H, 96H, 1506, 1510 |
| | | STAYER | 980B |
| ZB0920 | 92X5,5X1,1 | HITACHI | F30A |
| | | RYOBI | L120N, 1323 |
| | | TOWA | |
| ZB1030 | 103X5,5X1,1 | AEG | EH102, HB750, HBE800 |

2 PIECES HANGING PACKAGING



| | |
|----------|--------------|
| ZB0755X2 | 75x5,5x1,1 |
| ZB0805X2 | 80,5x5,9x1,2 |
| ZB0820X2 | 82x5,5x1,1 |
| ZB0920X2 | 92x5,5x1,1 |
| ZB1030X2 | 103x5,5x1,1 |

LAMINATE CUTTERS

ART. Y100



| Item | |
|------------|--|
| Y100.001.R | Two identical knives for cutting: Plastic material, Laminates etc. |
| Y100.002.R | Two identical knives for cutting: Side A: Laminates etc. Side B: Glass, Tiles etc. |

MAGNETIC ALIGNERS FOR PLANER KNIVES

ART. Y200

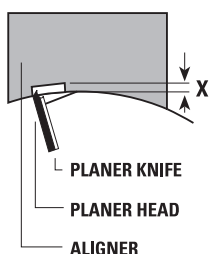

Klein magnetic aligners for planer knives have been specially designed for rapid knife positioning after sharpening. They are made of galvanized steel and feature permanent magnets.

In just a few minutes, in a simple and precise way, problems of knife alignment after sharpening are solved.

No adjustments are required. Simply position on cutterhead along the step where the knife is to be rested. All your knives will be parallel and positioned with the same working thickness.

| Item | ∅Planer head | X | Item | ∅Planer head | X |
|------------|--------------|---|------------|--------------|---|
| Y200.056.N | 56 | 1 | Y200.100.N | 100 | 1 |
| Y200.060.N | 60 | 1 | Y200.110.N | 110 | 1 |
| Y200.070.N | 70 | 1 | Y200.118.N | 118 | 1 |
| Y200.080.N | 80 | 1 | Y200.120.N | 120 | 1 |
| Y200.090.N | 90 | 1 | Y200.125.N | 125 | 1 |
| Y200.095.N | 95 | 1 | Y200.140.N | 140 | 1 |



PLANER KNIVES H=30/35

ART. ZC 30 - ZC 35

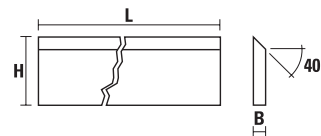

- HS= 18% W, suitable for softwood dry and hardwood wet
- 4 pcs. set

| Item | Quality | H | B | L |
|------------|---------|----|---|------|
| ZC30.060HS | HS | 30 | 3 | 60 |
| ZC30.080HS | HS | 30 | 3 | 80 |
| ZC30.100HS | HS | 30 | 3 | 100 |
| ZC30.120HS | HS | 30 | 3 | 120 |
| ZC30.180HS | HS | 30 | 3 | 180 |
| ZC30.200HS | HS | 30 | 3 | 200 |
| ZC30.210HS | HS | 30 | 3 | 210 |
| ZC30.230HS | HS | 30 | 3 | 230 |
| ZC30.250HS | HS | 30 | 3 | 250 |
| ZC30.260HS | HS | 30 | 3 | 260 |
| ZC30.300HS | HS | 30 | 3 | 300 |
| ZC30.310HS | HS | 30 | 3 | 310 |
| ZC30.350HS | HS | 30 | 3 | 350 |
| ZC30.400HS | HS | 30 | 3 | 400 |
| ZC30.410HS | HS | 30 | 3 | 410 |
| ZC30.430HS | HS | 30 | 3 | 430 |
| ZC30.500HS | HS | 30 | 3 | 500 |
| ZC30.510HS | HS | 30 | 3 | 510 |
| ZC30.520HS | HS | 30 | 3 | 520 |
| ZC30.530HS | HS | 30 | 3 | 530 |
| ZC30.600HS | HS | 30 | 3 | 600 |
| ZC30.610HS | HS | 30 | 3 | 610 |
| ZC30.630HS | HS | 30 | 3 | 630 |
| ZC30.810HS | HS | 30 | 3 | 810 |
| ZC30.999HS | HS | 30 | 3 | 1000 |
| ZC35.300HS | HS | 35 | 3 | 300 |
| ZC35.310HS | HS | 35 | 3 | 310 |
| ZC35.350HS | HS | 35 | 3 | 350 |
| ZC35.400HS | HS | 35 | 3 | 400 |
| ZC35.410HS | HS | 35 | 3 | 410 |
| ZC35.430HS | HS | 35 | 3 | 430 |
| ZC35.500HS | HS | 35 | 3 | 500 |
| ZC35.510HS | HS | 35 | 3 | 510 |
| ZC35.520HS | HS | 35 | 3 | 520 |
| ZC35.530HS | HS | 35 | 3 | 530 |
| ZC35.600HS | HS | 35 | 3 | 600 |
| ZC35.630HS | HS | 35 | 3 | 630 |
| ZC35.640HS | HS | 35 | 3 | 640 |
| ZC35.700HS | HS | 35 | 3 | 700 |
| ZC35.810HS | HS | 35 | 3 | 810 |
| ZC35.999HS | HS | 35 | 3 | 1000 |

PLANER KNIVES H=30/35

ART. ZC 30 - ZC 35

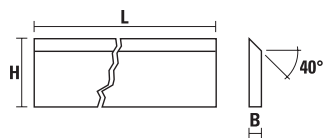

- HL= 13% Cr, suitable for softwood wet
- 4 pcs. set

| Item | Quality | H | B | L |
|------------|---------|----|---|------|
| ZC30.250HL | HL | 30 | 3 | 250 |
| ZC30.260HL | HL | 30 | 3 | 260 |
| ZC30.300HL | HL | 30 | 3 | 300 |
| ZC30.400HL | HL | 30 | 3 | 400 |
| ZC30.430HL | HL | 30 | 3 | 430 |
| ZC30.500HL | HL | 30 | 3 | 500 |
| ZC30.510HL | HL | 30 | 3 | 510 |
| ZC30.515HL | HL | 30 | 3 | 515 |
| ZC30.520HL | HL | 30 | 3 | 520 |
| ZC30.530HL | HL | 30 | 3 | 530 |
| ZC30.600HL | HL | 30 | 3 | 600 |
| ZC30.630HL | HL | 30 | 3 | 630 |
| ZC30.810HL | HL | 30 | 3 | 810 |
| ZC30.999HL | HL | 30 | 3 | 1000 |
| ZC35.300HL | HL | 35 | 3 | 300 |
| ZC35.350HL | HL | 35 | 3 | 350 |
| ZC35.400HL | HL | 35 | 3 | 400 |
| ZC35.410HL | HL | 35 | 3 | 410 |
| ZC35.430HL | HL | 35 | 3 | 430 |
| ZC35.500HL | HL | 35 | 3 | 500 |
| ZC35.510HL | HL | 35 | 3 | 510 |
| ZC35.520HL | HL | 35 | 3 | 520 |
| ZC35.530HL | HL | 35 | 3 | 530 |
| ZC35.600HL | HL | 35 | 3 | 600 |
| ZC35.610HL | HL | 35 | 3 | 610 |
| ZC35.630HL | HL | 35 | 3 | 630 |
| ZC35.640HL | HL | 35 | 3 | 640 |
| ZC35.740HL | HL | 35 | 3 | 740 |
| ZC35.810HL | HL | 35 | 3 | 810 |
| ZC35.999HL | HL | 35 | 3 | 1000 |

PLANER KNIVES H=30/35

ART. ZC 30 - ZC 35

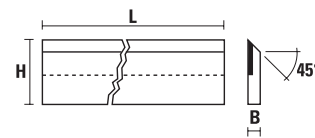
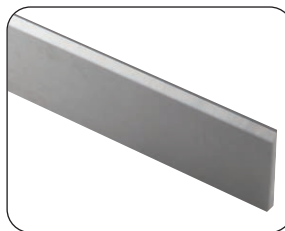

- HW= TCT
- 4 pcs. set
- Suitable for hardwood dry and pressed wood

| Item | Quality | H | B | L |
|------------|---------|----|---|------|
| ZC30.080HW | HW | 30 | 3 | 80 |
| ZC30.100HW | HW | 30 | 3 | 100 |
| ZC30.120HW | HW | 30 | 3 | 120 |
| ZC30.130HW | HW | 30 | 3 | 130 |
| ZC30.150HW | HW | 30 | 3 | 150 |
| ZC30.180HW | HW | 30 | 3 | 180 |
| ZC30.200HW | HW | 30 | 3 | 200 |
| ZC30.230HW | HW | 30 | 3 | 230 |
| ZC30.250HW | HW | 30 | 3 | 250 |
| ZC30.260HW | HW | 30 | 3 | 260 |
| ZC30.310HW | HW | 30 | 3 | 310 |
| ZC30.350HW | HW | 30 | 3 | 350 |
| ZC30.400HW | HW | 30 | 3 | 400 |
| ZC30.410HW | HW | 30 | 3 | 410 |
| ZC30.450HW | HW | 30 | 3 | 450 |
| ZC30.500HW | HW | 30 | 3 | 500 |
| ZC30.520HW | HW | 30 | 3 | 520 |
| ZC30.530HW | HW | 30 | 3 | 530 |
| ZC30.600HW | HW | 30 | 3 | 600 |
| ZC30.630HW | HW | 30 | 3 | 630 |
| ZC30.710HW | HW | 30 | 3 | 710 |
| ZC30.810HW | HW | 30 | 3 | 810 |
| ZC30.999HW | HW | 30 | 3 | 1040 |
| ZC35.300HW | HW | 35 | 3 | 300 |
| ZC35.320HW | HW | 35 | 3 | 320 |
| ZC35.400HW | HW | 35 | 3 | 400 |
| ZC35.500HW | HW | 35 | 3 | 500 |
| ZC35.520HW | HW | 35 | 3 | 520 |
| ZC35.600HW | HW | 35 | 3 | 600 |
| ZC35.630HW | HW | 35 | 3 | 630 |
| ZC35.640HW | HW | 35 | 3 | 640 |
| ZC35.710HW | HW | 35 | 3 | 710 |
| ZC35.810HW | HW | 35 | 3 | 810 |
| ZC35.999HW | HW | 35 | 3 | 1040 |

CORRUGATED BLANK KNIVES

ART. ZC 50 - ZC 60 - ZC 70

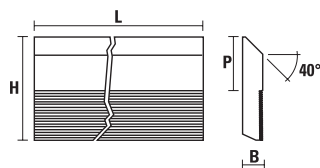

- **HS: 18% W**, suitable for softwood dry or wet and hardwood wet
- Precision serration, angle 60°, pitch 1,6 mm

| Item | H | B | L | Pmax |
|------------|----|---|-----|------|
| ZC50.060HS | 50 | 8 | 60 | 12 |
| ZC50.080HS | 50 | 8 | 80 | 12 |
| ZC50.100HS | 50 | 8 | 100 | 12 |
| ZC50.120HS | 50 | 8 | 120 | 12 |
| ZC50.130HS | 50 | 8 | 130 | 12 |
| ZC50.150HS | 50 | 8 | 150 | 12 |
| ZC50.180HS | 50 | 8 | 180 | 12 |
| ZC50.230HS | 50 | 8 | 230 | 12 |
| ZC50.260HS | 50 | 8 | 260 | 12 |
| ZC50.650HS | 50 | 8 | 650 | 12 |
| ZC60.060HS | 60 | 8 | 60 | 20 |
| ZC60.080HS | 60 | 8 | 80 | 20 |
| ZC60.100HS | 60 | 8 | 100 | 20 |
| ZC60.120HS | 60 | 8 | 120 | 20 |
| ZC60.130HS | 60 | 8 | 130 | 20 |
| ZC60.150HS | 60 | 8 | 150 | 20 |
| ZC60.180HS | 60 | 8 | 180 | 20 |
| ZC60.230HS | 60 | 8 | 230 | 20 |
| ZC60.260HS | 60 | 8 | 260 | 20 |
| ZC60.650HS | 60 | 8 | 650 | 20 |
| ZC70.060HS | 70 | 8 | 60 | 30 |
| ZC70.080HS | 70 | 8 | 80 | 30 |
| ZC70.100HS | 70 | 8 | 100 | 30 |
| ZC70.120HS | 70 | 8 | 120 | 30 |
| ZC70.130HS | 70 | 8 | 130 | 30 |
| ZC70.150HS | 70 | 8 | 150 | 30 |
| ZC70.180HS | 70 | 8 | 180 | 30 |
| ZC70.230HS | 70 | 8 | 230 | 30 |
| ZC70.260HS | 70 | 8 | 260 | 30 |
| ZC70.650HS | 70 | 8 | 650 | 30 |

CORRUGATED BLANK KNIVES

ART. ZC 50 - ZC 60 - ZC 70

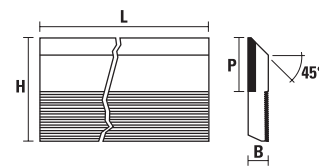

- **HW:** carbide tipped, suitable for hardwood dry, pressed wood
- Precision serration, angle 60°, pitch 1,6 mm

| Item | H | B | L | Pmax |
|------------|----|---|-----|------|
| ZC50.040HW | 50 | 8 | 40 | 20 |
| ZC50.050HW | 50 | 8 | 50 | 20 |
| ZC50.060HW | 50 | 8 | 60 | 20 |
| ZC50.080HW | 50 | 8 | 80 | 20 |
| ZC50.100HW | 50 | 8 | 100 | 20 |
| ZC50.120HW | 50 | 8 | 120 | 20 |
| ZC50.130HW | 50 | 8 | 130 | 20 |
| ZC50.150HW | 50 | 8 | 150 | 20 |
| ZC50.180HW | 50 | 8 | 180 | 20 |
| ZC50.230HW | 50 | 8 | 230 | 20 |
| ZC50.640HW | 50 | 8 | 640 | 20 |
| ZC60.040HW | 60 | 8 | 40 | 25 |
| ZC60.050HW | 60 | 8 | 50 | 25 |
| ZC60.060HW | 60 | 8 | 60 | 25 |
| ZC60.080HW | 60 | 8 | 80 | 25 |
| ZC60.100HW | 60 | 8 | 100 | 25 |
| ZC60.120HW | 60 | 8 | 120 | 25 |
| ZC60.130HW | 60 | 8 | 130 | 25 |
| ZC60.150HW | 60 | 8 | 150 | 25 |
| ZC60.180HW | 60 | 8 | 180 | 25 |
| ZC60.230HW | 60 | 8 | 230 | 25 |
| ZC60.640HW | 60 | 8 | 640 | 25 |
| ZC70.040HW | 70 | 8 | 40 | 30 |
| ZC70.050HW | 70 | 8 | 50 | 30 |
| ZC70.060HW | 70 | 8 | 60 | 30 |
| ZC70.080HW | 70 | 8 | 80 | 30 |
| ZC70.100HW | 70 | 8 | 100 | 30 |
| ZC70.120HW | 70 | 8 | 120 | 30 |
| ZC70.130HW | 70 | 8 | 130 | 30 |
| ZC70.150HW | 70 | 8 | 150 | 30 |
| ZC70.180HW | 70 | 8 | 180 | 30 |
| ZC70.230HW | 70 | 8 | 230 | 30 |
| ZC70.640HW | 70 | 8 | 640 | 30 |

TURNBLADES "TERSA"

ART. ZE 01

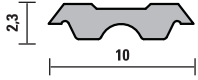

- Antioxidant treatment on knife body
- Polished cutting face for an excellent finish quality
- HS 18% for medium hard wood
- HW for very hard wood and abrasive materials
- M42 for hard wood, long-life performance

| Item | Quality | L |
|-------------|---------|-----|
| ZE01.060HS | HS | 60 |
| ZE01.100HS | HS | 100 |
| ZE01.130HS | HS | 130 |
| ZE01.180HS | HS | 180 |
| ZE01.230HS | HS | 230 |
| ZE01.310HS | HS | 310 |
| ZE01.330HS | HS | 330 |
| ZE01.410HS | HS | 410 |
| ZE01.430HS | HS | 430 |
| ZE01.510HS | HS | 510 |
| ZE01.520HS | HS | 520 |
| ZE01.530HS | HS | 530 |
| ZE01.630HS | HS | 630 |
| ZE01.640HS | HS | 640 |
| ZE01.060HW | HW | 60 |
| ZE01.100HW | HW | 100 |
| ZE01.130HW | HW | 130 |
| ZE01.180HW | HW | 180 |
| ZE01.230HW | HW | 230 |
| ZE01.310HW | HW | 310 |
| ZE01.330HW | HW | 330 |
| ZE01.410HW | HW | 410 |
| ZE01.430HW | HW | 430 |
| ZE01.510HW | HW | 510 |
| ZE01.520HW | HW | 520 |
| ZE01.530HW | HW | 530 |
| ZE01.630HW | HW | 630 |
| ZE01.640HW | HW | 640 |
| ZE01.650HW | HW | 650 |
| ZE01.060M42 | M42 | 60 |
| ZE01.100M42 | M42 | 100 |
| ZE01.130M42 | M42 | 130 |
| ZE01.180M42 | M42 | 180 |
| ZE01.230M42 | M42 | 230 |
| ZE01.310M42 | M42 | 310 |
| ZE01.330M42 | M42 | 330 |
| ZE01.410M42 | M42 | 410 |
| ZE01.430M42 | M42 | 430 |
| ZE01.510M42 | M42 | 510 |
| ZE01.520M42 | M42 | 520 |
| ZE01.530M42 | M42 | 530 |
| ZE01.630M42 | M42 | 630 |
| ZE01.640M42 | M42 | 640 |

Other dimensions available on request

TURNBLADES "CENTROLOCK"

ART. ZE 02

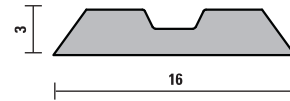

- Antioxidant treatment on knife body
- Polished cutting face for an excellent finish quality
- HS 18% for medium hard wood
- HW for very hard wood and abrasive materials

| Item | Quality | L |
|------------|---------|-----|
| ZE02.020HS | HS | 20 |
| ZE02.080HS | HS | 80 |
| ZE02.150HS | HS | 150 |
| ZE02.210HS | HS | 210 |
| ZE02.240HS | HS | 240 |
| ZE02.300HS | HS | 300 |
| ZE02.360HS | HS | 360 |
| ZE02.460HS | HS | 460 |
| ZE02.020HW | HW | 20 |
| ZE02.110HW | HW | 110 |
| ZE02.160HW | HW | 160 |
| ZE02.200HW | HW | 200 |
| ZE02.220HW | HW | 220 |
| ZE02.250HW | HW | 250 |
| ZE02.275HW | HW | 275 |
| ZE02.280HW | HW | 280 |
| ZE02.350HW | HW | 350 |
| ZE02.450HW | HW | 450 |

TURNBLADES "CENTROFIX - QUICKFIX" - "CENTROSTAR"

ART. ZE 03

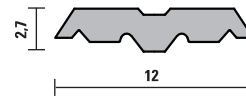

- Antioxidant treatment on knife body
- Polished cutting face for an excellent finish quality
- HS 18% for medium hard wood
- HW for very hard wood and abrasive materials

| Item | Quality | L |
|------------|---------|-----|
| ZE03.130HS | HS | 130 |
| ZE03.150HS | HS | 150 |
| ZE03.180HS | HS | 180 |
| ZE03.210HS | HS | 210 |
| ZE03.230HS | HS | 230 |
| ZE03.310HS | HS | 310 |
| ZE03.410HS | HS | 410 |
| ZE03.430HS | HS | 430 |
| ZE03.510HS | HS | 510 |
| ZE03.520HS | HS | 520 |
| ZE03.530HS | HS | 530 |
| ZE03.630HS | HS | 630 |
| ZE03.640HS | HS | 640 |
| ZE03.930HS | HS | 930 |
| ZE03.130HW | HW | 130 |
| ZE03.180HW | HW | 180 |
| ZE03.230HW | HW | 230 |
| ZE03.310HW | HW | 310 |
| ZE03.410HW | HW | 410 |
| ZE03.430HW | HW | 430 |
| ZE03.510HW | HW | 510 |
| ZE03.520HW | HW | 520 |
| ZE03.630HW | HW | 630 |
| ZE03.640HW | HW | 640 |
| ZE03.650HW | HW | 650 |

Other dimensions available on request

TURNBLADES "TERMINUS"

ART. ZE 04

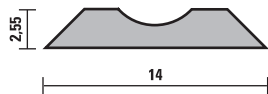

- Antioxidant treatment on knife body
- Polished cutting face for an excellent finish quality
- HS 18% for medium hard wood
- HW for very hard wood and abrasive materials

| Item | Quality | L |
|------------|---------|-----|
| ZE04.130HS | HS | 130 |
| ZE04.180HS | HS | 180 |
| ZE04.210HS | HS | 210 |
| ZE04.230HS | HS | 230 |
| ZE04.310HS | HS | 310 |
| ZE04.520HS | HS | 520 |
| ZE04.650HS | HS | 650 |
| ZE04.130HW | HW | 130 |
| ZE04.180HW | HW | 180 |
| ZE04.210HW | HW | 210 |
| ZE04.230HW | HW | 230 |
| ZE04.310HW | HW | 310 |
| ZE04.520HW | HW | 520 |
| ZE04.650HW | HW | 650 |

Other dimensions available on request

TURNBLADES "BULLDOZER"

ART. ZE 05

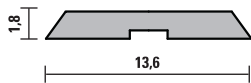

- Antioxidant treatment on knife body
- Polished cutting face for an excellent finish quality
- HW for very hard wood and abrasive materials

| Item | Quality | L |
|------------|---------|-----|
| ZE05.100HW | HW | 100 |
| ZE05.130HW | HW | 130 |
| ZE05.150HW | HW | 150 |
| ZE05.210HW | HW | 210 |
| ZE05.230HW | HW | 230 |
| ZE05.265HW | HW | 265 |

Other dimensions available on request

TURNBLADES "ENSHIN"

ART. ZE 06

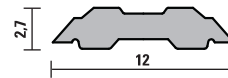

- Antioxidant treatment on knife body
- Polished cutting face for an excellent finish quality
- HS 18% for medium hard wood
- HW for very hard wood and abrasive materials

| Item | Quality | L |
|------------|---------|-----|
| ZE06.080HS | HS | 80 |
| ZE06.130HS | HS | 130 |
| ZE06.150HS | HS | 150 |
| ZE06.210HS | HS | 210 |
| ZE06.240HS | HS | 240 |
| ZE06.080HW | HW | 80 |
| ZE06.130HW | HW | 130 |
| ZE06.150HW | HW | 150 |
| ZE06.210HW | HW | 210 |
| ZE06.240HW | HW | 240 |
| ZE06.640HW | HW | 640 |

Other dimensions available on request

TURNBLADES "SINUS"

ART. ZE 07

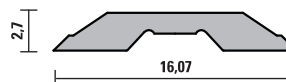

- Antioxidant treatment on knife body
- Polished cutting face for an excellent finish quality
- HS 18% for medium hard wood
- HW for very hard wood and abrasive materials

| Item | Quality | L |
|-------------|---------|------|
| ZE07.080HS | HS | 80 |
| ZE07.130HS | HS | 130 |
| ZE07.180HS | HS | 180 |
| ZE07.210HS | HS | 210 |
| ZE07.250HS | HS | 250 |
| ZE07.310HS | HS | 310 |
| ZE07.430HS | HS | 430 |
| ZE07.510HS | HS | 510 |
| ZE07.630HS | HS | 630 |
| ZE07.1050HS | HS | 1050 |
| ZE07.080HW | HW | 80 |
| ZE07.130HW | HW | 130 |
| ZE07.180HW | HW | 180 |
| ZE07.210.HW | HW | 210 |
| ZE07.250HW | HW | 250 |
| ZE07.310HW | HW | 310 |
| ZE07.430HW | HW | 430 |
| ZE07.510HW | HW | 510 |
| ZE07.630HW | HW | 630 |

Other dimensions available on request

TURNBLADES "VARIPLAN"

ART. ZE 08

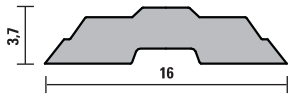

- Antioxidant treatment on knife body
- Polished cutting face for an excellent finish quality
- HS 18% for medium hard wood
- HW for very hard wood and abrasive materials

| Item | Quality | L |
|------------|---------|-----|
| ZE08.050HS | HS | 50 |
| ZE08.100HS | HS | 100 |
| ZE08.130HS | HS | 130 |
| ZE08.180HS | HS | 180 |
| ZE08.210HS | HS | 210 |
| ZE08.410HS | HS | 410 |
| ZE08.430HS | HS | 430 |
| ZE08.510HS | HS | 510 |
| ZE08.600HS | HS | 600 |
| ZE08.630HS | HS | 630 |
| ZE08.050HW | HW | 50 |
| ZE08.100HW | HW | 100 |
| ZE08.130HW | HW | 130 |
| ZE08.180HW | HW | 180 |
| ZE08.210HW | HW | 210 |
| ZE08.410HW | HW | 410 |
| ZE08.430HW | HW | 430 |
| ZE08.510HW | HW | 510 |
| ZE08.600HW | HW | 600 |
| ZE08.630HW | HW | 630 |

Other dimensions available on request

TURNBLADES "BRÜCK"

ART. ZE 09

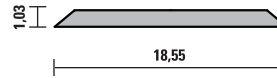

- Antioxidant treatment on knife body
- Polished cutting face for an excellent finish quality
- HS 18% for medium hard wood
- HSCo (cobalt) for very hard wood and abrasive materials

| Item | Quality | L |
|--------------|---------|-----|
| ZE09.060HS | HS | 60 |
| ZE09.100HS | HS | 100 |
| ZE09.130HS | HS | 130 |
| ZE09.180HS | HS | 180 |
| ZE09.210HS | HS | 210 |
| ZE09.250HS | HS | 250 |
| ZE09.310HS | HS | 310 |
| ZE09.400HS | HS | 400 |
| ZE09.450HS | HS | 450 |
| ZE09.510HS | HS | 510 |
| ZE09.630HS | HS | 630 |
| ZE09.810HS | HS | 810 |
| ZE09.060HSCo | HSCo | 60 |
| ZE09.100HSCo | HSCo | 100 |
| ZE09.130HSCo | HSCo | 130 |
| ZE09.180HSCo | HSCo | 180 |
| ZE09.210HSCo | HSCo | 210 |
| ZE09.250HSCo | HSCo | 250 |
| ZE09.310HSCo | HSCo | 310 |
| ZE09.400HSCo | HSCo | 400 |
| ZE09.450HSCo | HSCo | 450 |
| ZE09.510HSCo | HSCo | 510 |
| ZE09.630HSCo | HSCo | 630 |
| ZE09.810HSCo | HSCo | 810 |

Other dimensions available on request

TURNBLADES "ESTA"

ART. ZE 10

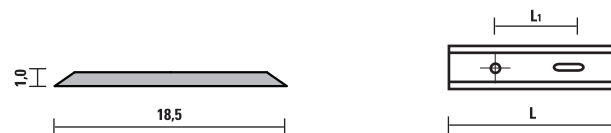

- Antioxidant treatment on knife body
- Polished cutting face for an excellent finish quality
- HS 18% for medium hard wood
- Up to L= 280 (20 pcs packaging)
- From L= 280 (12 pcs packaging)

| Item | Quality | L | L1 | n. holes | n. slots |
|------------|---------|-----|-----|----------|----------|
| ZE10.060HS | HS | 60 | 45 | 1 | 1 |
| ZE10.100HS | HS | 100 | 45 | 1 | 1 |
| ZE10.130HS | HS | 130 | 45 | 1 | 2 |
| ZE10.200HS | HS | 200 | 45 | 1 | 2 |
| ZE10.300HS | HS | 300 | 100 | 1 | 2 |
| ZE10.400HS | HS | 400 | 100 | 2 | 3 |
| ZE10.500HS | HS | 500 | 100 | 1 | 4 |
| ZE10.650HS | HS | 650 | 200 | 1 | 3 |
| ZE10.810HS | HS | 810 | 200 | 1 | 3 |

Other dimensions available on request

Sawblades

12



HW SAWBLADES FOR PORTABLE MACHINES
Page 12.12



HW SAWBLADES FOR PORTABLE MACHINES
Page 12.13



HW SAWBLADES FOR PORTABLE MACHINES
Page 12.13



HW GROOVING CUTTER FOR "LAMELLO"[®]
Page 12.13



DP GROOVE CUTTER FOR "LAMELLO"[®] JOINTS
Pag. 12.13



HW MULTI PURPOSE CIRCULAR SAWBLADES
Page 12.14



HW TRIMMING FINISHING
Page 12.15



HW MULTI PURPOSE SAWBLADES (thin kerf)
Page 12.16



HW MULTI PURPOSE CIRCULAR SAWBLADES
Page 12.16



HW MULTI PURPOSE CIRCULAR SAWBLADES
Page 12.17



HW RADIAL ARM SAWBLADES
Page 12.17



HW TRIMMING AND SIZING SAWBLADES
Page 12.17



HW TRIMMING AND SIZING SAWBLADES
Page 12.18



HW TRIMMING AND SIZING SAWBLADES "EXTRA CUT"
Page. 12.18

Xtra cut



HW MULTIRIP SAWBLADES WITHOUT RAKERS
Page 12.19



HW SHOULDER RIP SAWBLADES WITH RAKERS
Page 12.19



HW MULTIRIP SAWBLADES WITH RAKERS
Page 12.20



HW MULTIRIP SAWBLADES WITH RAKERS (THIN KERF)
Page 12.20



Klein[®]



HW CONICAL SCORING SAWBLADES
Page 12.27



HW ADJUSTABLE SCORING SAWBLADES
Page 12.28



HW PANEL SIZING SAWBLADES
Page 12.28



HW PANEL SIZING SAWBLADES
Page 12.29



HW SCORING SAWBLADES FOR EDGE BANDING AND SQUARING MACHINES
Page 12.30



HW SCORING SAWBLADES FOR EDGE BANDING AND SQUARING MACHINES
Page 12.30



HW SAWBLADES FOR BUILDING SITES
Page 12.31



HW SAWBLADES FOR ALUMINIUM
Page 12.32



HW SAWBLADES FOR ALUMINIUM
Page 12.32



HW SAWBLADES FOR PVC
Page 12.33



HW GROOVING SAWBLADES
Page 12.33



HW "DRY" OR "QUATTRO" SAWBLADES
Page 12.34



HW SAWBLADES FOR "SOLID SURFACE"
Page 12.34



HW SAWBLADES FOR PVC AND PLEXIGLASS
Page 12.34



HW SAWBLADES FOR FRAMES
Page 12.35



HW SAWBLADES FOR "SANDWICH" PANELS
Page 12.35



HW DMo5 SAWBLADES FOR FERROUS MATERIALS
Page 12.35



DP SAWBLADES
Page 12.36



DP CONICAL SCORING SAWBLADES
Page 12.36



DP ADJUSTABLE SCORING SAWBLADES
Page 12.36



DP PANEL SIZING SAWBLADES
Page 12.37



DP SAWBLADES FOR CUTTING ABRASIVE MATERIALS
Pag. 12.37



REDUCTION RINGS FOR SAWBLADES
Page 12.38

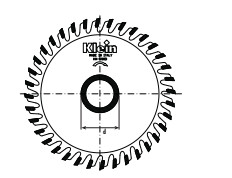

SPECIAL SAWBLADE REBORING
Page 12.38



SAFETY PIN HOLES FOR SAWBLADES
Page 12.38

T.C.T. SAWBLADES

Klein sawblades are high quality products, guaranteed by the choice of raw materials developed in collaboration with leading European manufacturers of steel and carbide (i. e. our carbide tips are produced by Ceratizit). Throughout the production cycle, controls are followed extremely scrupulous and final acceptance ensures that all the characteristics of the blades **Klein** are meeting the highest standards of quality. At the end the production lots are numbered and filed.

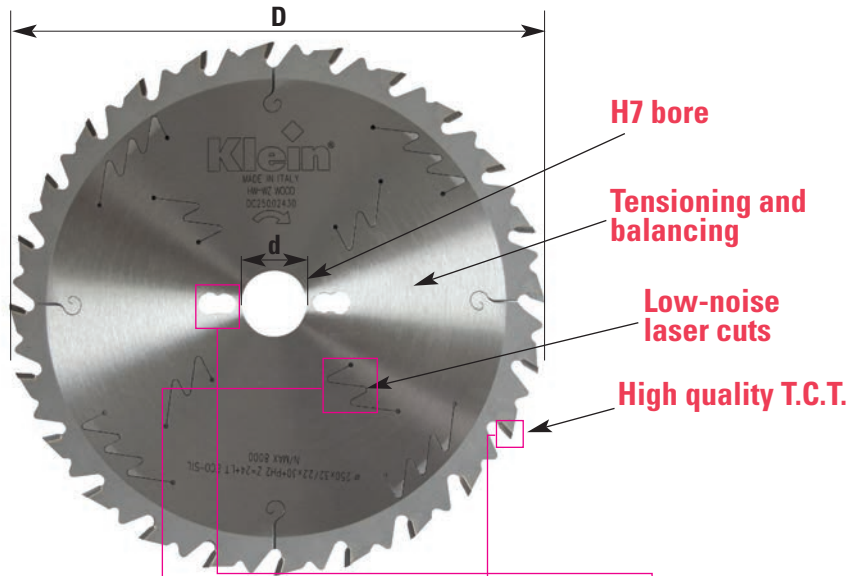

The sawblades **Klein** are exclusively worked with laser cutting. **Bores and keyways are honed to ensure maximum precision (h7)**. Without this process there will be a visible mark on the bore edge.

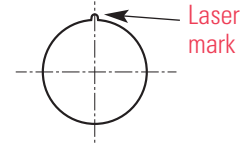

Tensioning and balancing are operated with completely automatic machines, which assure **the absence of vibrations and higher quality results**.

| Item | D | d | B/c | Z | α | P. holes |
|--------------|-----|----|---------|----|----------|----------|
| CCS250.04830 | 250 | 30 | 3,2/2,2 | 48 | 15° | PH02 |
| CCS300.06030 | 300 | 30 | 3,2/2,2 | 60 | 15° | PH02 |

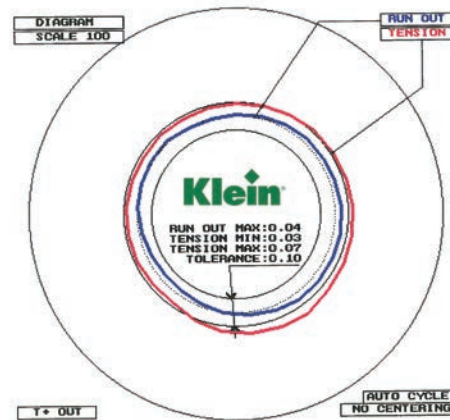
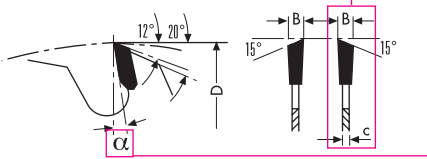

Low noise sawblades

According to the latest technical tests, our saw blades are manufactured **with an advanced system of noise reduction guaranteed by an attentive position of the laser ornaments**, different for each diameter (🎵).

The body of the saw blade remains solid and perfectly tensioned while sound waves generated during the working process are absorbed either longitudinally or crosswise.

The laser ornaments in the sizing saw blades (Items HBS/HBC) **and in the saw blades for cutting PVC (item LE) and for cutting aluminium (items LA/LB) are filled up with a special soundproofing plastic resin** (🎵), resistant to ultrasound and high temperatures. Considerably lowering the vibrations, the tool can work longer and perform a better finish cut, also after its resharpening.

Quality of tungsten carbide used:

| Quality | Composition | Grain size | Bending strength | Hardness | Density | Toughness | Wear resistance |
|---------------------------------------|--------------|--|----------------------------|------------------------------------|-------------------------|----------------------------|------------------------|
| KCR05 ISO: K01 USA: C4 | Co+Ni 2,76%, | Ultrafine grain 0,2- \angle 0,5 μ m | 2500 MPa 363.000 P.S.I. | 2150 HV10 2110 HV30 94,4 HRA | 15,20 g/cm ³ | 6,0 MPa.m ^{-1/2} | 0 1 2 3 4 5 6 7 8 9 10 |
| KCR06 ISO: K01 USA: C4 | Co+Ni 3,0%, | Micrograin 0,5- \angle 0,8 μ m | 2300 MPa 334.000 P.S.I. | 1950 HV10 1910 HV30 93,6 HRA | 15,25 g/cm ³ | 8,5 MPa.m ^{-1/2} | 0 1 2 3 4 5 6 7 8 9 10 |
| HC10 ISO: K10 USA: C3 | Co 5,6%, | Fine grain 0,8- \angle 1,3 μ m | 2150 MPa 334.000 P.S.I. | 1760 HV10 1730 HV30 92,7 HRA | 15,00 g/cm ³ | 9,2 MPa.m ^{-1/2} | 0 1 2 3 4 5 6 7 8 9 10 |
| HC20 ISO: K20 USA: C2-C3 | Co 6,0%, | Fine grain 0,8- \angle 1,3 μ m | 2200 MPa 334.000 P.S.I. | 1640 HV10 1620 HV30 92,1 HRA | 15,00 g/cm ³ | 9,9 MPa.m ^{-1/2} | 0 1 2 3 4 5 6 7 8 9 10 |
| SMX ISO: P20-P25 USA: C6 | Co 10.5%, | Fine grain 0,8- \angle 1,3 μ m | 2200 MPa 316.000 P.S.I. | 1550 HV10 1530 HV30 91,5 HRA | 12,65 g/cm ³ | 10,0 MPa.m ^{-1/2} | 0 1 2 3 4 5 6 7 8 9 10 |

Technical data and images are just an indication. **SISTEMI** srl reserves the right to modify the above information at any time and without notice.

Diagram for determining the peripheral cutting speed:

Diagram shows the peripheral cutting speed in m/sec, defined RPM and sawblades diameter.

V_t = cutting speed (m/sec)
D = sawblades diameter (mm)
n = RPM

$$V_t = \frac{D \times \pi \times n}{60 \times 1.000}$$

| RPM \ D=mm | 1500 | 2000 | 2500 | 2800 | 3000 | 3500 | 4000 | 4500 | 5000 | 5600 | 6000 | 8000 | 9000 | 10000 | 12000 | 18000 |
|------------|------|------|------|------|------|------|------|------|------|------|------|------|------|-------|-------|-------|
| 80 | 6,5 | 8,5 | 10,5 | 12 | 13 | 14 | 15 | 19,1 | 21 | 23,5 | 26 | 34 | 38 | 42 | 52 | 76 |
| 90 | 7 | 9,5 | 12 | 13,5 | 14 | 16 | 17 | 21 | 24 | 26,5 | 28 | 38 | 42 | 48 | 56 | 84 |
| 100 | 8 | 10 | 13 | 15 | 16 | 18 | 21 | 24 | 26 | 29 | 31 | 41 | 47 | 52 | 63 | 96 |
| 120 | 9,5 | 13 | 16 | 18 | 19 | 22 | 25 | 28 | 31 | 35 | 38 | 49 | 57 | 63 | 65 | |
| 125 | 10 | 14 | 16,5 | 20 | 19,5 | 24 | 27 | 31 | 34 | 36,5 | 41 | 53 | 61 | 68 | 82 | |
| 140 | 11 | 15 | 18 | 21 | 22 | 26 | 29 | 33 | 37 | 41 | 44 | 57 | 66 | 73 | 88 | |
| 150 | 12 | 16 | 19,5 | 22 | 23,5 | 27 | 31 | 35 | 39 | 44 | 47 | 63 | 71 | 79 | 94 | |
| 160 | 13 | 17 | 21 | 24 | 26 | 29 | 33 | 38 | 42 | 47 | 50 | 65 | 75 | 84 | | |
| 180 | 14 | 19 | 24 | 27 | 28 | 33 | 42 | 42 | 47 | 53 | 57 | 73 | 85 | 94 | | |
| 200 | 16 | 21 | 26 | 29 | 32 | 37 | 42 | 47 | 52 | 58,5 | 63 | 81 | 94 | | | |
| 225 | 17 | 23 | 30 | 32 | 36 | 40 | 46 | 52 | 58 | 66 | 69 | 92 | 104 | | | |
| 250 | 20 | 26 | 33 | 37 | 40 | 46 | 52 | 59 | 65 | 73,5 | 79 | | | | | |
| 300 | 24 | 31 | 40 | 44 | 48 | 55 | 63 | 71 | 79 | 88 | 94 | | | | | |
| 350 | 27 | 37 | 47 | 51 | 56 | 64 | 73 | 83 | 92 | 105 | | | | | | |
| 400 | 31 | 42 | 54 | 59 | 64 | 73 | 83 | 92 | 105 | | | | | | | |
| 450 | 35 | 47 | 59 | 66 | 70,5 | 83 | 94 | 105 | | | | | | | | |
| 500 | 39 | 52 | 67 | 73 | 80 | 92 | | | | | | | | | | |

- Mineral fibreplates
- Wood-based material, plastic material and non-ferrous metal
- Hardwood
- Softwood
- Safety limit

Recommended peripheral cutting speed:

| CUTTING MATERIAL | Peripheral cutting speed (m/s) | Feed rate (mm/z) |
|---|--------------------------------|------------------|
| Softwood | Cutting along grain | 58÷100 |
| | Cutting across grain | 60÷100 |
| Hardwood | Cutting along grain | 61÷100 |
| | Cutting across grain | 65÷100 |
| Exotic timber | Cutting along grain | 58÷100 |
| Plywood | | 55÷80 |
| Particle board | | 60÷85 |
| HDF | | 60÷80 |
| MDF | | 60÷80 |
| Playwood boards, veneered or coated on both sides | | 60÷100 |
| Laminated boards | | 55÷80 |
| Melamine | | 58÷80 |
| Thermoplastic | | 50÷75 |
| Duroplastic | | 30÷60 |
| Aluminium profiles | | 35÷70 |

Pin holes as per following details:

Scale 1:1

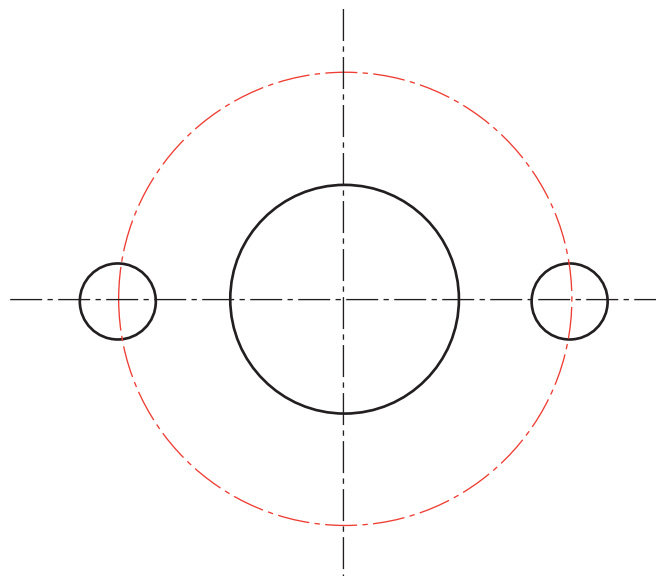

PH01

| Name | Nr of holes/diameter of holes/pitch circle diameter |
|------|---|
| PH01 | 2/10/60 |

Scale 1:1

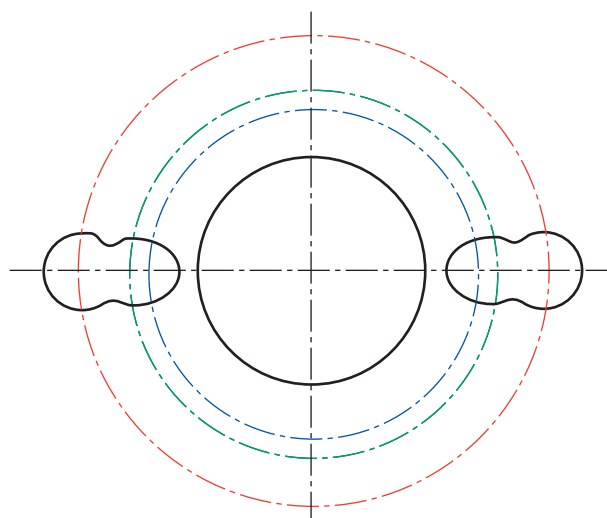

PH02

| Name | Nr of holes/diameter of holes/pitch circle diameter | Machine type |
|------|---|--------------|
| PH02 | 2/7/42 + 2/9,5/46,5 + 2/10/60 | Universal |

Instructions for a correct use of sawblades:

- 1- Be sure the spindle where the sawblade has to be mounted is clean and balanced;
- 2- Be sure the sawblade is perfectly aligned with the working table;
- 3- Be sure the working parameters (feed rate, cutting speed, etc.) are correct;
- 4- Never exceed the RPM indicated on the sawblade, otherwise it can be dangerous for the operator;
- 5- Check time to time the state of the cutting tips and, in case, let the sawblade professionally resharpened;
- 6- When processing thicker material, reduce the number of teeth;
- 7- Use flanges of the same diameter of the saw blade to secure it (or at least 1/3 of the blade's diameter);
- 8- The machine must be in perfect condition, without any unusual vibrations;
- 9- Reduce the number of teeth when processing thicker material.

Reference table for the choice of the right sawblade (X= sufficient - XX= good - XXX= excellent) **Information just as a guide**

| Item | Natural woods | | | | | | Pressed woods | | Board materials | | | Paper and mineral fiber |
|---|-----------------------------------|-----------|---------------------------------|-----------|---------------|-----------|---------------|---------------|-----------------|----------|-----------|-------------------------|
| | SOFTWOOD (cider, poplar, pine) | | HARDWOOD (ash, walnut, teak) | | EXOTIC TIMBER | | PLYWOOD | PARTIAL BOARD | BLOCK BOARD | VENEERED | LAMINATED | |
| | Rip cut | Cross cut | Rip cut | Cross cut | Rip cut | Cross cut | | | | | | |
| Art. AA - Page 12.12 | XXX | XXX | XXX | XXX | XX | XX | X | X | XX | XX | X | |
| Art. AB - Page 12.13 | | | | | | | | | | | | |
| Art. AL - Page 12.13 | | | | | | | | | | | | |
| Art. CA - Page 12.14 | X | XX | X | XX | X | X | XX | XXX | X | | | |
| Art. CB - Page 12.14 | XXX | XX | XXX | XX | XX | XX | X | XXX | XX | XX | X | XXX |
| Art. CC - Page 12.14 | XX | XX | XXX | XXX | X | XX | XX | XXX | XX | XX | X | X |
| Art. CD - Page 12.15 | XXX | XX | XXX | XXX | X | XXX | XX | XXX | XXX | XX | XX | |
| Art. CE - Page 12.15 | X | XX | XXX | XXX | XXX | XXX | XXX | XXX | X | XX | XX | |
| Art. CF - Page 12.16 | X | X | X | XX | XX | XX | | | X | XX | XXX | |
| Art. CG - Page 12.16 | XX | XXX | XX | XXX | XX | XXX | XXX | XXX | X | XX | XX | X |
| Art. CH - Page 12.16 | XX | XXX | XX | XXX | XX | XXX | XXX | XXX | X | XX | XX | XXX |
| Art. DA - Page 12.16 | XXX | X | XXX | X | | | X | X | | | | |
| Art. DC - Page 12.17 | XXX | XX | XXX | XX | XXX | X | XX | X | XX | XX | XX | |
| Art. FAS - Page 12.17 | | XX | | XX | | X | | | | | X | |
| Art. FB - Page 12.17 | | | | | | | XXX | XX | XX | XXX | XXX | |
| Art. FCS - Page 12.18 | | | | | | | XX | XXX | XXX | XXX | XXX | |
| Art. FE - Page 12.19 | XXX | XX | XX | XX | XX | XX | X | X | | | | |
| Art. FG - Page 12.19 | XXX | XX | XXX | XX | XX | XX | X | X | | | | |
| Art. FH - Page 12.20 | XXX | XX | XXX | XX | XX | XX | X | X | | | | |
| Art. FK - Page 12.20 | XXX | XX | XXX | XX | XX | XX | X | X | | | | |
| Art. FI - Page 12.27 | | | | | | | XX | XXX | XXX | XXX | XXX | |
| Art. FL - Page 12.28 | | | | | | | XX | XXX | XXX | XXX | XXX | |
| Art. FM - Page 12.30 | | | | | | | XX | XXX | XXX | XXX | XXX | |
| Art. FP - Page 12.30 | | | | | | | XX | XXX | XXX | XXX | XXX | |
| Art. GA - Page 12.31 | XXX | XX | XXX | XX | X | X | | | | | | |
| Art. HBS - Page 12.28 | | | | | | | X | XX | XX | XX | XX | |
| Art. HCS - Page 12.29 | | | | | | | XXX | XXX | XXX | XXX | XXX | |
| Art. KA - Page 12.33 | XXX | XXX | XXX | XX | XXX | XX | XX | | | | | |
| Art. LA - Page 12.32 | | | | | | | | | | | | |
| Art. LB - Page 12.32 | | | | | | | | | | | | |
| Art. LZ - Page 12.34 | X | X | XX | XX | X | X | X | X | | | | |
| Art. MES - Page 12.34 | | | | | | | | | | | | |
| Art. MGS/LE Pages 12.33/12.34 | | | | | | | | | | | | |
| A.MLS/MMS - P. 12.34 | XXX | XXX | XXX | XXX | XX | XX | XX | XX | X | XX | XX | |
| Art. MP - Page 12.34 | | | | | | | | | | | | |
| Art. PA - Page 12.35 | | | | | | | | | | | | |
| Art. PB - Page 12.35 | | | | | | | | | | | | |
| Art. XFC - Page 12.35 | X | X | XX | XX | XXX | XXX | XXX | XXX | XXX | XX | XX | |
| Art. XFI - Page 12.36 | X | X | XX | XX | XXX | XXX | XXX | XXX | XXX | XX | XX | |
| Art. XHC - Page 12.37 | X | X | XX | XX | XXX | XXX | XXX | XXX | XXX | XX | XX | |

Reference table for the choice of the right sawblade (X= sufficient - XX= good - XXX= excellent) Information just as a guide









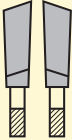
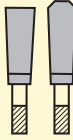

| Item | Panels | | | Plastic materials | | | Sandwich | Non-ferrous materials | | | Ferrous materials | |
|---|--------|-----|----------------|-------------------|--------------|----------------------|----------|-----------------------|------------|-----------------|-------------------|-------|
| | FIBER | | PLASTIC COATED | THERMOPLASTIC | DUROPLASTICS | WITH PLASTIC BINDERS | | ALUMINIUM PROFILES | ALLUMINIUM | ALUMINIUM ALOYS | PROFILES | SOLID |
| | HDF | MDF | | | | | | | | | | |
| Art. AA - Page 12.12 | | | | | | | | | | | | |
| Art. AB - Page 12.13 | | | | XXX | XX | XX | | XX | XX | XX | | |
| Art. AL - Page 12.13 | | | | XX | XX | XX | | XXX | XX | XX | | |
| Art. CA - Page 12.14 | | X | | | | | | | | | | |
| Art. CB - Page 12.14 | X | X | | | | | | | | | | |
| Art. CC - Page 12.14 | X | X | | | | | | | | | | |
| Art. CD - Page 12.15 | X | X | | | | | | | | | | |
| Art. CE - Page 12.15 | XX | XX | | XXX | XX | X | | | | | | |
| Art. CF - Page 12.16 | | XX | | | | | | | | | | |
| Art. CG - Page 12.16 | X | XX | X | XX | XX | XX | | | | | | |
| Art. CH - Page 12.16 | | | | XXX | XX | XX | | | | | | |
| Art. DA - Page 12.16 | | | | | | | | | | | | |
| Art. DC - Page 12.17 | | X | | X | | | | | | | | |
| Art. FAS - Page 12.17 | | | XXX | | | X | | | | | | |
| Art. FB - Page 12.17 | XX | XX | XXX | XXX | XXX | X | | | | | | |
| Art. FCS - Page 12.18 | XX | XXX | XX | XX | XX | X | X | | | | | |
| Art. FE - Page 12.19 | | | | | | | | | | | | |
| Art. FG - Page 12.19 | | | | | | | | | | | | |
| Art. FH - Page 12.20 | | | | | | | | | | | | |
| Art. FK - Page 12.20 | | | | | | | | | | | | |
| Art. FI - Page 12.27 | XXX | XXX | XXX | | | | | | | | | |
| Art. FL - Page 12.28 | XXX | XXX | XXX | | | | | | | | | |
| Art. FM - Page 12.30 | XXX | XXX | XXX | | | | | | | | | |
| Art. FP - Page 12.30 | XX | XX | XXX | X | X | XX | | | | | | |
| Art. GA - Page 12.31 | | | | | | | | | | | | |
| Art. HBS - Page 12.28 | XX | XX | X | | | | | | | | | |
| Art. HCS - Page 12.29 | XXX | XXX | XXX | X | XXX | X | | | | | | |
| Art. KA - Page 12.33 | | | | | | | | | | | | |
| Art. LA - Page 12.32 | | | | | | | | XX | XXX | XXX | | |
| Art. LB - Page 12.32 | | | | | | | | XXX | XX | XX | | XX |
| Art. LZ - Page 12.34 | | | | X | X | X | | XX | XX | XX | XXX | |
| Art. MES - Page 12.34 | | | | X | XXX | XX | | | | | | |
| Art. MGS/LE Pages 12.33/12.34 | | | | XX | XXX | X | | | | | | |
| A.MLS/MMS - P. 12.34 | XX | XXX | XX | | | | | | | XX | | |
| Art. MP - Page 12.34 | | | | | | | XXX | | | | | |
| Art. PA - Page 12.35 | | | | | | | | | | | XXX | XXX |
| Art. PB - Page 12.35 | | | | | | | | | | | XXX | XXX |
| Art. XFC - Page 12.35 | XXX | XXX | XXX | X | X | | | X | X | X | | |
| Art. XFI - Page 12.36 | XXX | XXX | XX | X | X | | | X | X | X | | |
| Art. XHC - Page 12.37 | XXX | XXX | XX | X | X | | | X | X | X | | |

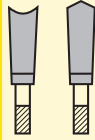
Number of teeth suggested:

Calculation of the number of teeth, given the diameter of the saw blade and the thickness of the material to be worked.

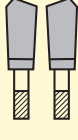
$$Z \text{ (nr. theet)} = \frac{D \text{ (diameter/mm)} \times K}{Sp \text{ (thickness/mm)}}$$

K = 7 for ripcutting on natural wood
K = 9 for ripping or crosscutting
K = 11 for crosscutting of hard woods and hard materials

| | | | |
|---|--|---|--|
|  <p>WZ: alternate top bevel teeth, suitable for soft and hardwood, fibre materials, MDF. Especially clean cuts.</p> |  <p>FZ/TR: triple chip teeth form, suitable for solid wood, plastic coated materials, non ferrous profiles, hardwood.</p> |  <p>FZ: flat teeth, suitable for cutting along grain on large cutting height soft and hardwood.</p> |  <p>HZ/DZ: Hollow tooth/inverted V-tooth, suitable for saw benches on plastic coated chipboards and fibre materials.</p> |
|  <p>FZ/FA: Flat tooth with bevel, with chip limiter, for cutting timber, also in presence of concrete or metal remains, nails, etc.</p> |  <p>LFZ: flat teeth with chip limiter, suitable for table saws. For cutting along and across grain in wooden boarding materials.</p> |  <p>KON/FZ: conical tooth, used on scoring blades</p> |  <p>WZ/FA: alternate top bevel teeth, suitable for soft and hardwood, fibre materials, MDF. Especially clean cuts.</p> |
|  <p>TR: trapezoidal tooth, used on saw blades "dry" (Item LZ).</p> |  <p>ES: (ES-L/ES-R) One-sided top bevel tooth (right or left), used on edge banding machines or hogging units.</p> |  <p>BW: special tooth shape for item "PB" (steel blade, for cutting metals).</p> |  <p>C: special tooth shape for item "PA" (steel blade, for cutting metals).</p> |

Klein saw blades for portable machines are delivered in hanging packaging while those for industrial machines in a very robust carton packaging.

PACKAGING SAW BLADES FOR PORTABLE MACHINES



PACKAGING SAW BLADES FOR INDUSTRIAL MACHINES



| | |
|------------------|-------------------|
| Sawblades | Dimensions |
| Ø127÷Ø140 | 165x179x5 |
| Ø150÷Ø190 | 215x234x5 |
| Ø200÷Ø240 | 254x277x5 |

| | |
|------------------|-------------------|
| Sawblades | Dimensions |
| Ø80÷Ø150 | 210x210x15 |
| Ø160÷Ø210 | 255x255x15 |
| Ø220÷Ø250 | 300x300x15 |
| Ø280÷Ø300 | 355x355x15 |
| Ø320÷Ø350 | 400x400x15 |
| Ø355÷Ø400 | 455x455x15 |
| Ø420÷Ø500 | 550x550x15 |
| Ø520÷Ø600 | 655x655x15 |
| Ø620÷Ø700 | 725x725x20 |

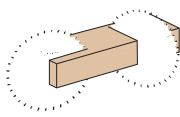
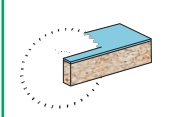
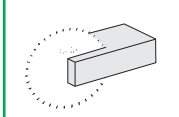
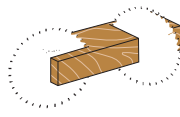
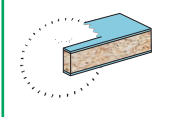
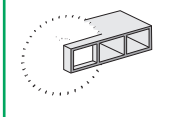
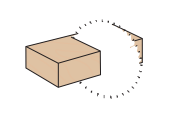
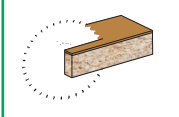
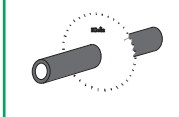
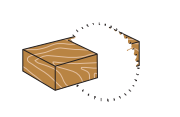
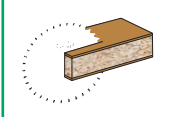
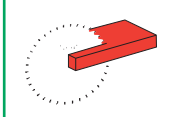
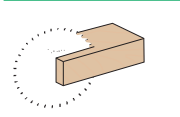
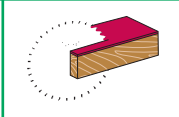
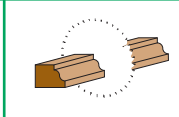
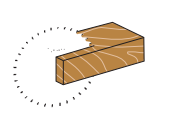
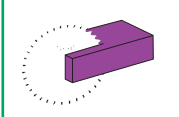
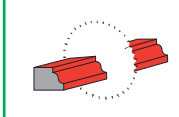
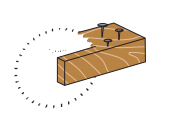
Symbols:

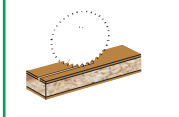
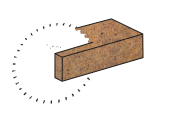
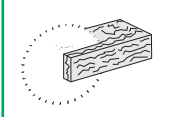
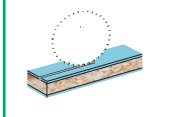
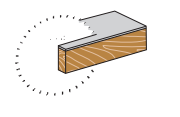
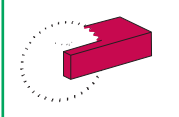
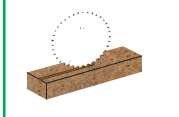
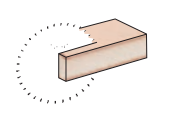
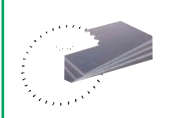
| | | |
|--|--|--|
|  <p>Art. AA - CB - CA - CF DC - KA - LZ XFC - XFI - XHC</p> <p>For cutting along and across grain of softwood</p> |  <p>Art. CD - CE - CF DC</p> <p>For cutting single side laminate board</p> |  <p>Art. LB</p> <p>For cutting aluminium</p> |
|  <p>Art. AA - CB - CC DC - KA - LZ XFC - XFI - XHC</p> <p>For cutting along and across grain of hardwood</p> |  <p>Art. FB - FCS - FCT - FM - FP - HBS - HCS - MMS - XFC XHC - XFI</p> <p>For cutting double side laminate board</p> |  <p>Art. AL - LA - LZ</p> <p>For cutting aluminium profiles</p> |
|  <p>Art. FAS</p> <p>For cutting across grain of softwood</p> |  <p>Art. AA - CB - CC CD - CE - CG CH - DC</p> <p>For cutting single side veneer board</p> |  <p>Art. LZ - PA - PB</p> <p>For cutting steel and ferrous materials</p> |
|  <p>Art. CD - CE CG - FAS</p> <p>For cutting across grain of hardwood</p> |  <p>Art. FB - FCS - FCT - FI FM - FP - HBS HCS - XFC XFI - XHC</p> <p>For cutting double side veneer board</p> |  <p>Art. LA - LB - LE MGS</p> <p>For cutting PVC</p> |
|  <p>Art. DA - FE - FG FH - FK</p> <p>For cutting along grain of softwood</p> |  <p>Art. FAS - FCS - FCT FP</p> <p>For cutting plastic coated materials</p> |  <p>Art. MLS</p> <p>For cutting wood frames</p> |
|  <p>Art. CA - DA - FE FG - FH - FK</p> <p>For cutting along grain of hardwood</p> |  <p>Art. MES</p> <p>For cutting CORIAN®</p> |  <p>Art. MLS</p> <p>For cutting PVC frames</p> |
|  <p>Art. AB - AL GA - GB</p> <p>For cutting wood for construction with small metal parts</p> |  <p>Art. GA - GB</p> <p>For working on building sites</p> |  <p>Art. FI - FL</p> <p>Scoring sawblades for cutting veneer board</p> |
|  <p>Art. CE - CG - FCS FCT - FM - FP HBS - HCS XFC - XFI - XHC</p> <p>For cutting MDF</p> |  <p>Art. CB - CC - CH</p> <p>For cutting paper coated materials</p> |  <p>Art. FI - FL</p> <p>Scoring sawblades for cutting laminate materials</p> |
|  <p>Art. FAS</p> <p>For cutting aluminium wood profiles</p> |  <p>Art. AB - AL FB - LZ MES - MGS</p> <p>For cutting plastic materials</p> |  <p>Art. FI - FL</p> <p>Scoring sawblades for cutting MDF</p> |
|  <p>Art. MP</p> <p>For cutting "Sandwich" panels</p> |  <p>Art. CH - MES - MGS</p> <p>For cutting plexiglass</p> | |

REFERENCE TABLE FOR PORTABLE MACHINES

| Diameter | Producer | Model |
|------------|---|--|
| 125 x 12,7 | B & D | DN55, DN56, D985, D984, DN254 |
| 127 x 12,7 | B & D | DN55, DN56, D985, D984, DN254 |
| 130 x 16 | Bosch Metabo | PKS240, PKS40 S, S43 BHK01, KS3340 S, 4340, 6311, BHK2, MaxKS40 S |
| 134 x 20 | AEG Holz-Her Peugeot | TKS42 2110, 2111, 2171, Mosquito S SC42 C |
| 140 x 12,7 | B & D | DN227, DN227 H, BD227, BD846, BD 228 |
| 140 x 16 | Makita | 5000SBR, 500, 5000GB, N500 |
| 140 x 20 | Bosch Holz-Her Metabo AEG Peugeot Stayer | 1551, 1559 2260, 2270, 170, 260, 270 BTK, C1, C2, BTKO HK 40 SC47 C, HKS 700, Profiline, SC 1 Profiline, CP 46 |
| 150 x 13 | Kress Mafell Skil | 6006, 6018, 9060, HKS400, 6000, 6010 Biberella 533, 553 |
| 150 x 16 | Bosch Scheer/Ryobi Skil | PKS46, S33, S1, GKS12V, GB1923 (England) MS 50 52465 |
| 150 x 20 | AEG B & D Casals De Walt Felisatti Metabo Perles Stayer Peugeot Hitachi Fein Skil Elu Scheer/Ryobi Makita | HK45A, HK50, HK52, HKS52, HK737 HK46S, AHK52, HK46N, HK46, HK45 P88.09 BSC150, VSC50 DW 351 TP 751 4341S, KS52 S, KS0846, BTK0, 62, 61, KS0846 S, KS0852 S, KSE0946 S KS50 CP50 SC53 C, SC52, SC52 C, SC46 C5, FC5, FC5 SA SSK646 1850H, 1850 MH151 MS45, 45E, MS45-3 5600 B |
| 150 x 30 | Festo Elu | AXF45, AF45 E MH18 |
| 156 x 12,7 | B & D | DN228, DN57, SR352E, BD228, P36-01, BD228L, BD228CK, SR352 |

Use reduction rings Art. ZA page 10.14
to have different bores in your sawblades

REFERENCE TABLE FOR PORTABLE MACHINES

| Diameter | Producer | Model |
|----------|---|---|
| 160 x 16 | B & D Bosch Peugeot Rockwell Ryobi Scheer Skil Ulmia | M336, M975, M976, BD855 PKS54, GKS54CE, PKS54CE, GKS54 SC4510XA 63416 W5502 C FM 534, 536, 552B, 416H, 1409H, 1408H, 552H, 1855H, 367, 856, 1410H 1607, 1610 |
| 160 x 20 | AEG Atlas Copco Festool Haffner Hitachi Mafell Makita Metabo Kress Holz-Her Ryobi Fein Festo Protool Techline Tip Valex | HK55A, HK55B, HK160A, HK160B K55S, K55SE T555 KSU50 FC65A, C6DA X55, XE55, PS52, MKS55, MS55, A55, B55, FU50 5600NB, 5600 DW KS1155S 6050, 6055 Duo, 1050KS HKU50, HKU264, 1420, 2103, 2104, 2105, 2106 W-560 (P), W5502 SSK660 ATF55E, ATF55, AP55E, AP55, AP55E-FS CSP55 EHS 160 HKS 160 SC 160 |
| 160 x 30 | Festo Mafell | AU50, AUP50, AAU KS320 |
| 165 x 20 | Festo | 5603R |
| 170 x 20 | Makita Mafell | 5600 BR B55, FK50, A55, FUS50 |
| 170 x 30 | Elu Festo Holz-Her Haffner Bosch Hitachi | MH 155, MH55, MH 65 AM42S+A, AMT42S, AXT55, AT55E, AXT50LA 2115(t55A), 2266, 2271, 2281, 281, HKUS266 KSU110 1552, 1556, 1563, GKS55 PSU6, C-6SA |
| 180 x 20 | Makita Haffner Peugeot Metabo Ryobi B & D | SR1800, 5800B, 5801 B, 5800, 5800N, S800BR KSU60, SKU113 FIP50S 6317S W-66N, W-651A, W-6502 HS1200, HD2062 |
| 180 x 30 | Elu Bosch Festo Holz-Her Haffner | MH65 0550, 1560, 1557, 1550, 1553 AU60S, AU55S, AU60P, AUT60S, AUT42S 2112, HKU55, HKU2272, HKU2291, 2113, 2292, 2282, 2269 KSU113 |

Use reduction rings Art. ZA page 10.14
to have different bores in your sawblades

REFERENCE TABLE FOR PORTABLE MACHINES

| Diameter | Producer | Model |
|-----------------------|-------------|--|
| 184 x 16 | B & D | HD1000, DN59, DN229, DN820 |
| | | SR300, P37-03, P37-05, GD60, |
| | | HD1200P, HD2062, SEC718, SR362E |
| | | BD229, BD865E |
| | Skil | 1865U, 77, 77U, 537, 553B, 553H, |
| | | 559, 559U, 574U, 857, 1865H |
| | Wolf | 6070 |
| | Peugeot | SC66C, SC650, 10XA, SC65C |
| | Rockwell | 315, 4500, 63417 |
| | 190 x 16 | Bosch |
| Skil | | 1865U, 1965U, 1865H |
| 190 x 20 | Makita | 5800BR, 3501 |
| | Kress | 6060, CHKS6060, 1400KS, 1600KS, |
| | | 1600HTKS |
| | Metabo | KS4345S, 5348, KS4346S, KS65S, |
| Robert, BTK, KSE1668S | | |
| 190 x 30 | AEG | HK65A, HK65, HKS65, HK190, HK66, |
| | | HKS66, HKSE66, HKE66, HKS65A |
| | Atlas Copco | K66S, K66SE |
| | Holz-Her | 2116(t-65a), 2117(t65i), 2127, 2119, |
| | | 2269(t65e), 2126, 2282, 2114, 2292, 2113 |
| | Bosch | 1553, 0051, 1564, PKS66, GKS66CE, |
| | | GKS65, PKS66CE |
| | De walt | DW65, DW365 |
| | Elu | MH165 |
| | Hitachi | FC75A, PSM-7, PSU-7 |
| | Felisatti | TP765, TP766 |
| | Festo | AP65E, AP65E-FS, AT65E |
| | Mafell | MKS65 |
| | Skil | 1965U |
| | Scheer | MS 65 |
| Makita | 5703R | |
| 200 x 16 | B & D | M338 |
| | Hanning | TK200, TK20S, TK20N, TK300 |
| | Ulmia | 1607, 1708 |
| | Ryobi | W750 |
| | | |
| 200 x 30 | Festo | AU65S, AD65, AXP65, AXP200, |
| | | AP68E, AP65S |
| | AEG | HK200, HK201 |
| | Bosch | 1561, 0551 |
| | Haffner | AKS |
| | Mafell | B65, X72 |
| | Holz-Her | 2113, 2292, 2555 |
| | Kity | 0618 |
| | Scheer | MS 70, FM16DNC, |
| | | FM16Electronic, FM16Standard |
| | Makita | 5700 |
| | Ulmia | 1706 |
| | Valex | SC200 |
| | 210 x 25 | Makita |
| Skil | | 1524H, 1873H, 1525, 1886, 1985, 1986 |

Use reduction rings Art. ZA page 10.14
to have different bores in your sawblades

REFERENCE TABLE FOR PORTABLE MACHINES

| Diameter | Producer | Model |
|----------|-------------------|------------------------------------|
| 210 x 30 | AEG | HK75A, HK75, HKS75 |
| | Atlas Copco | HKS75 |
| | Fein | SSK661 |
| | Elu | MH82, MH182, MH30 |
| | Casals | SC210, VSC70 |
| | B & D | SEC818, DN800, DN810, PS174, |
| | | SR700, P38.02, BD800, HD2075S |
| | Bosch | 1554, 1588, 1565, GKS75S |
| | Haffner | RS75, KSU118 |
| | Hitachi | PSU8, PSM8, C8U, C8FA |
| | Holz-Her | 2264, 2267, 2284, PKS267, 2279 |
| | Mafell | MKS75, MKS85S, MS75 |
| | Perles | KS70 |
| | Skil | 1873H, 1524H |
| Metabo | KSE 1678, KG 1670 | |
| 216 x 30 | De Walt | DW712, DW771, DW777 |
| 220 x 20 | Flott | 2000, KS3000 |
| | Schleicher | Compact151 |
| 220 x 30 | Festo | AU77S, |
| | Haffner | KL177, KL178, KSU118 |
| | Holz-Her | PKS+HKU75, 274, 1205, 1331, |
| | | 1342, 1345, 1346, 2279 |
| | Metabo | 6322S |
| Scheer | MS80, M585 | |
| 225 x 30 | Festo | CS70EB |
| 230 x 30 | Holz-Her | 2218(t85i), 2120(t85e), 2293, 2294 |
| | | AEG |
| | Atlas Copco | HKS85 |
| | B & D | P39-02, SEC918, HD2086S |
| | Bosch | 1562, 0052, 1566, GKS85S |
| | Casals | SC230 |
| | Haffner | SP187, KS85, HUS85 |
| | Skil | 1886H |
| | Scheer | MS85 |
| | | |
| 235 x 25 | Makita | SR2300, 5900BR, 5900B, 5900 |
| 235 x 30 | De Walt | DW383 |
| | Haffner | KL176, KS85, KSU85, SP187 |
| | B & D | P39-02, SEC 918 |
| | Skil | 1986 |
| | Makita | 5903R |
| | Hitachi | C9U, PSM9, PSU9 |
| 240 x 30 | Festo | AXP85, AP85E, AP88E, AP85-E-TS |
| | Holz-Her | 2268, HKD65 |
| | Metabo | 6323 S, KS1785S, KS6323S Automatic |
| | Elu | MH85 |
| | Bosch | 1555 |
| | Mafell | B82, MKS85 |
| | Hitachi | PSM-9, PSU-9 |
| | AEG | HK240 |
| | De Walt | DW86 |
| | | |
| 305 x 30 | De Walt | DW718, DWS780 |

Use reduction rings Art. ZA page 10.14
to have different bores in your sawblades

HW SAWBLADES FOR PORTABLE MACHINES

ART. AA

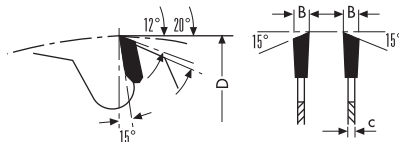

- Fine cut HW sawblades
- **WZ** alternate top bevel teeth
- For cutting along and across grain of **softwood, hardwood, exotic timber and veneer boards**
- High teeth number sawblades best finishing cut
- **HW grade: HC10 (K10-C3)**

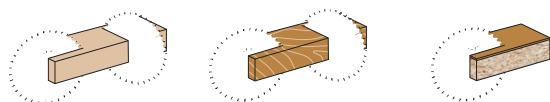

| Item | D | d | B/c | Z | Pin holes |
|-------------|-------|------|---------|----|-------------|
| AA127.03613 | 125 | 12,7 | 2,6/1,6 | 36 | |
| AA130.02016 | 130 | 16 | 2,6/1,6 | 20 | |
| AA130.03616 | 130 | 16 | 2,6/1,6 | 36 | |
| AA134.03620 | 134 | 20 | 2,6/1,6 | 36 | |
| AA140.02013 | 140 | 12,7 | 2,6/1,6 | 20 | |
| AA140.02016 | 140 | 16 | 2,6/1,6 | 20 | |
| AA140.02020 | 140 | 20 | 2,6/1,6 | 20 | |
| AA140.03020 | 140 | 20 | 2,6/1,6 | 30 | |
| AA140.04213 | 140 | 12,7 | 2,6/1,6 | 42 | |
| AA140.04216 | 140 | 16 | 2,6/1,6 | 42 | |
| AA140.04220 | 140 | 20 | 2,6/1,6 | 42 | |
| AA150.02016 | 150 | 16 | 2,6/1,6 | 24 | |
| AA150.02020 | 150 | 20 | 2,6/1,6 | 24 | |
| AA150.02030 | 150 | 30 | 2,6/1,6 | 24 | |
| AA150.03016 | 150 | 16 | 2,6/1,6 | 40 | |
| AA150.03020 | 150 | 20 | 2,6/1,6 | 40 | |
| AA150.04820 | 150 | 20 | 2,6/1,6 | 48 | |
| AA150.04830 | 150 | 30 | 2,6/1,6 | 48 | |
| AA156.04813 | 156,5 | 12,7 | 2,6/1,8 | 48 | selling out |
| AA160.02416 | 160 | 16 | 2,6/1,6 | 24 | 2/6/32 |
| AA160.02420 | 160 | 20 | 2,6/1,6 | 24 | 2/6/32 |
| AA160.02430 | 160 | 30 | 2,6/1,6 | 24 | 2/7/42 |
| AA160.03016 | 160 | 16 | 2,6/1,6 | 30 | 2/6/32 |
| AA160.03020 | 160 | 20 | 2,6/1,6 | 30 | 2/6/32 |
| AA160.03030 | 160 | 30 | 2,6/1,6 | 30 | 2/7/42 |
| AA160.04816 | 160 | 16 | 2,6/1,6 | 48 | 2/6/32 |
| AA160.04820 | 160 | 20 | 2,6/1,6 | 48 | 2/6/32 |
| AA165.02420 | 165 | 20 | 2,6/1,8 | 24 | |
| AA170.03030 | 170 | 30 | 2,6/1,6 | 30 | 2/7/42 |
| AA170.05230 | 170 | 30 | 2,6/1,6 | 52 | 2/7/42 |

| Item | D | d | B/c | Z | Pin holes |
|-------------|-----|----|---------|----|-------------|
| AA180.02420 | 180 | 20 | 2,6/1,6 | 24 | 2/6/32 |
| AA180.02430 | 180 | 30 | 2,6/1,6 | 24 | 2/7/42 |
| AA180.03020 | 180 | 20 | 2,6/1,6 | 40 | 2/6/32 |
| AA180.03030 | 180 | 30 | 2,6/1,6 | 40 | 2/7/42 |
| AA180.05620 | 180 | 20 | 2,6/1,6 | 56 | 2/6/32 |
| AA180.05630 | 180 | 30 | 2,6/1,6 | 56 | 2/7/42 |
| AA184.03016 | 184 | 16 | 2,6/1,6 | 30 | |
| AA184.05616 | 184 | 16 | 2,6/1,6 | 56 | |
| AA190.02416 | 190 | 16 | 2,6/1,6 | 24 | 2/6/32 |
| AA190.02420 | 190 | 20 | 2,6/1,6 | 24 | 2/6/32 |
| AA190.02430 | 190 | 30 | 2,6/1,6 | 24 | 2/7/42 |
| AA190.03616 | 190 | 16 | 2,6/1,6 | 40 | 2/6/32 |
| AA190.03620 | 190 | 20 | 2,6/1,6 | 40 | 2/6/32 |
| AA190.03630 | 190 | 30 | 2,6/1,6 | 40 | 2/7/42 |
| AA190.05616 | 190 | 16 | 2,6/1,6 | 56 | 2/6/32 |
| AA190.05620 | 190 | 20 | 2,6/1,6 | 56 | 2/6/32 |
| AA190.05630 | 190 | 30 | 2,6/1,6 | 56 | 2/7/42 |
| AA200.02430 | 200 | 30 | 2,6/1,8 | 24 | 2/7/42 |
| AA200.03630 | 200 | 30 | 2,6/1,8 | 36 | 2/7/42 |
| AA200.06430 | 200 | 30 | 2,6/1,8 | 64 | 2/7/42 |
| AA210.02430 | 210 | 30 | 2,8/1,8 | 24 | 2/7/42 |
| AA210.03625 | 210 | 25 | 2,8/1,8 | 36 | 2/7/42 |
| AA210.03630 | 210 | 30 | 2,8/1,8 | 36 | 2/7/42 |
| AA210.06430 | 210 | 30 | 2,8/1,8 | 64 | 2/7/42 |
| AA220.02430 | 220 | 30 | 2,6/1,8 | 24 | selling out |
| AA220.03630 | 220 | 30 | 2,8/1,8 | 36 | 2/7/42 |
| AA220.06430 | 220 | 30 | 2,8/1,8 | 64 | 2/7/42 |
| AA225.03430 | 225 | 30 | 2,6/1,8 | 34 | 2/7/42 |
| AA230.02430 | 230 | 30 | 2,8/1,8 | 24 | 2/7/42 |
| AA230.03630 | 230 | 30 | 2,8/1,8 | 36 | 2/7/42 |
| AA230.06430 | 230 | 30 | 2,8/1,8 | 64 | 2/7/42 |
| AA235.03625 | 235 | 25 | 2,8/1,8 | 36 | 2/7/42 |
| AA235.03630 | 235 | 30 | 2,8/1,8 | 36 | 2/7/42 |
| AA235.06430 | 235 | 30 | 2,8/1,8 | 64 | 2/7/42 |
| AA240.03630 | 240 | 30 | 2,8/1,8 | 36 | 2/7/42 |
| AA240.07230 | 240 | 30 | 2,8/1,8 | 72 | 2/7/42 |

BASE 1 modular panel

Small display, ideal for starting with a basic assortment
Dimensions (cm): 110 (L) x 90 (H) x 30 (P)



HW SAWBLADES FOR PORTABLE MACHINES

ART. AB

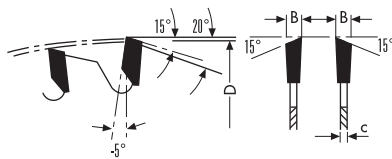

- Fine cut HW sawblades
- **WZ** alternate top bevel teeth
- For cutting **plastic materials** and **wood for construction with small metal parts**
- **5° negative** hook angle
- **HW grade: HC10 (K10-C3)**

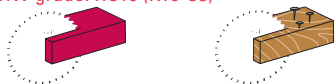

| Item | D | d | B/c | Z |
|-------------|-----|----|---------|----|
| AB216.02430 | 216 | 30 | 3,0/2,0 | 24 |
| AB216.04830 | 216 | 30 | 3,0/2,0 | 48 |
| AB216.06030 | 216 | 30 | 3,0/2,0 | 60 |
| AB305.06030 | 305 | 30 | 3,2/2,2 | 60 |

HW SAWBLADES FOR PORTABLE MACHINES

ART. AL

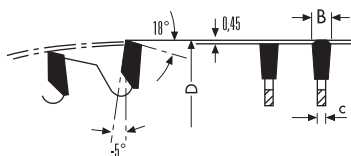

- Fine cut HW sawblades
- **FZ/TR** triple chip teeth
- For cutting **Alu-panels, laminated materials, plastics, solid surface** and **wood for construction with small metal parts**
- **5° negative** hook angle
- **HW grade: HC10 (K10-C3)**

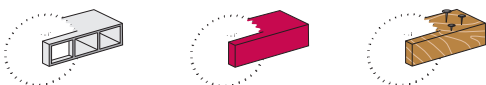

| Item | D | d | B/c | Z |
|-------------|-----|----|---------|----|
| AL160.02416 | 160 | 16 | 2,6/1,6 | 40 |
| AL160.02420 | 160 | 20 | 2,6/1,6 | 40 |
| AL160.05620 | 160 | 20 | 2,2/1,6 | 56 |
| AL180.02420 | 180 | 20 | 2,6/1,6 | 48 |
| AL190.03020 | 190 | 20 | 2,6/1,6 | 54 |
| AL190.03030 | 190 | 30 | 2,6/1,6 | 54 |
| AL210.03430 | 210 | 30 | 2,6/1,6 | 54 |
| AL216.06030 | 216 | 30 | 3,0/2,0 | 64 |
| AL220.03430 | 220 | 30 | 3,0/2,0 | 64 |

HW GROOVING CUTTER FOR "LAMELLO®"

ART. AH

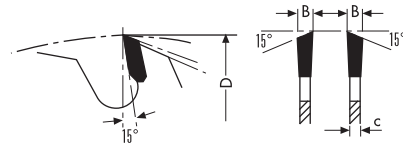

Grooving cutter for "Lamello®"

- Fine cut HW sawblades
- **WZ** alternate top bevel teeth
- **For grooving of "Lamello®" joints**
- **HW grade: HC10 (K10-C3)**



| Item | D | d | B/c | Z |
|-------------|-----|----|----------|----|
| AH100.10622 | 100 | 22 | 3,96/2,8 | 8 |
| AH100.21222 | 100 | 22 | 3,96/2,8 | 12 |



"Lamello®"-groove cutter

- **For grooving of "Lamello®" joints**
- Cutter with 2 teeth positive + 4 teeth negative for best finishing cut
- **HW grade: HC10 (K10-C3)**



| Item | D | d | B/c | Z |
|-------------|-----|----|----------|---------------|
| AH100.20622 | 100 | 22 | 3,96/2,8 | 2 pos.+4 neg. |

Cutter with reversible knives art. TAH100.20622 (page 13.22)

DP GROOVE CUTTER FOR "LAMELLO®" JOINTS

ART. XAH

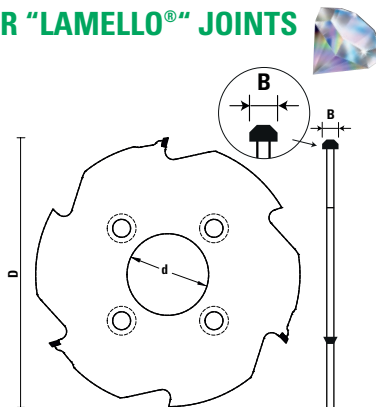

- **Suitable for making Clamex P connecting fittings** for furniture, shelf units and kitchen making
- To be used both on CNC machines and ZETA P2 hand power tool
- Recommended for grooving corner and longitudinal joints on hardwood, veneered and laminated MDF with the P-System anchorage

| Item | D | d | B | Z | Pin holes |
|-------------------------|-------|----|---|---|-----------|
| XAH100.10330 NEW | 100,4 | 30 | 7 | 3 | 4/6,6/48 |
| XAH100.10630 NEW | 100,4 | 30 | 7 | 6 | 4/6,6/48 |
| XAH100.10322 NEW | 100,4 | 22 | 7 | 3 | 4/4/36 |

CLAMEX P JOINTS



P-SYSTEM ANCHORAGE

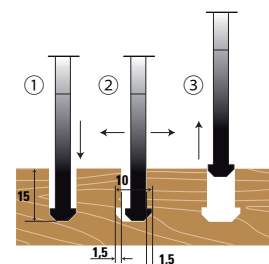

HW MULTI PURPOSE CIRCULAR SAWBLADES

ART. CA - CB/CBS - CC/CCS

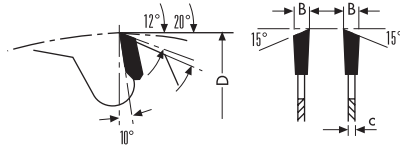

- WZ alternate top bevel teeth
- Suitable for table saws and panels saws
- Suitable for **particle board in stack**
- = no-noise
- HW grade: KCR06 (K01-C4)

Pin holes: PH01= 2/10/60 - PH02=2/7/42 + 2/9,5/46,5 + 2/10/60

ART. CA

- Suitable for ripping of **hardwood and plywood** for cutting across grain suitable for **softwood**

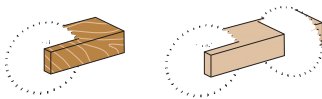

| Item | D | d | B/c | Z | α | Pin holes |
|--|-----|----|---------|----|-----|-----------|
| CA200.02430 <small>selling out</small> | 200 | 30 | 3,2/2,2 | 24 | 14° | |
| CA250.03030 | 250 | 30 | 3,2/2,2 | 30 | 14° | PH02 |
| CA300.03630 | 300 | 30 | 3,2/2,2 | 36 | 14° | PH02 |
| CA350.04230 | 350 | 30 | 3,5/2,5 | 42 | 14° | PH02 |
| CA400.04830 | 400 | 30 | 4,0/2,8 | 48 | 14° | PH02 |
| CA450.05430 | 450 | 30 | 4,2/2,8 | 54 | 14° | PH01 |
| CA500.06030 | 500 | 30 | 4,2/2,8 | 60 | 14° | PH01 |
| CA550.06030 | 550 | 30 | 5,2/3,6 | 60 | 14° | PH01 |
| CA600.06030 | 600 | 30 | 5,2/3,6 | 60 | 14° | PH01 |
| CA700.06440 | 700 | 40 | 6,2/4,0 | 64 | 14° | PH01 |

ART. CB - CBS

- For cutting along and across grain of **softwood and hardwood**, **single sided veneer-paper boards and plywood**

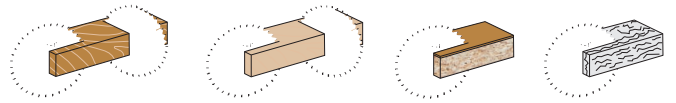

| Item | D | d | B/c | Z | α | Pin holes |
|--------------|-----|----|---------|----|-----|-----------|
| CB 100.02020 | 100 | 20 | 3,2/2,2 | 20 | 15° | |
| CB 120.02020 | 120 | 20 | 3,2/2,2 | 20 | 15° | |
| CB 150.02430 | 150 | 30 | 3,2/2,2 | 24 | 15° | |
| CB 180.03030 | 180 | 30 | 3,2/2,2 | 30 | 15° | |
| CB 200.03230 | 200 | 30 | 3,2/2,2 | 34 | 15° | |
| CBS250.04230 | 250 | 30 | 3,2/2,2 | 40 | 15° | PH02 |
| CBS300.04830 | 300 | 30 | 3,2/2,2 | 48 | 15° | PH02 |
| CBS350.05430 | 350 | 30 | 3,5/2,5 | 54 | 15° | PH02 |
| CBS350.05435 | 350 | 35 | 3,5/2,5 | 54 | 15° | PH02 |
| CBS400.06030 | 400 | 30 | 4,0/2,8 | 60 | 15° | PH02 |
| CB 450.06630 | 450 | 30 | 4,2/2,8 | 66 | 15° | PH01 |
| CB 500.07230 | 500 | 30 | 4,2/2,8 | 72 | 15° | PH01 |
| CB 600.08030 | 600 | 30 | 5,2/3,6 | 80 | 15° | PH01 |
| CB 700.08440 | 700 | 40 | 6,2/4,0 | 84 | 15° | PH01 |

ART. CC - CCS

- For cutting along and across grain fine finish suitable for **hardwood**, **single sided veneer-plastic boards, plywood and hardwood**

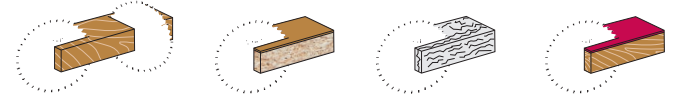

| Item | D | d | B/c | Z | α | Pin holes |
|--------------|-----|----|---------|----|-----|-----------|
| CC 200.04230 | 200 | 30 | 3,2/2,2 | 42 | 15° | |
| CCS250.04830 | 250 | 30 | 3,2/2,2 | 48 | 15° | PH02 |
| CCS300.06030 | 300 | 30 | 3,2/2,2 | 60 | 15° | PH02 |
| CCS350.07230 | 350 | 30 | 3,5/2,5 | 72 | 15° | PH02 |
| CC 400.08430 | 400 | 30 | 4,0/2,8 | 80 | 15° | PH02 |

HW TRIMMING FINISHING

ART. CD/CDS - CE/CES

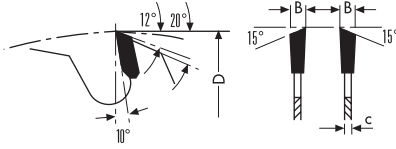

- WZ alternate top bevel teeth
- Suitable for table saws and panels saws
- Suitable for **particle board in stack**
- ♪ = no-noise
- HW grade: KCR06 (K01-C4)

Pin holes: **PH01**= 2/10/60 - **PH02**=2/7/42 + 2/9,5/46,5 + 2/10/60

ART. CD - CDS

- For cutting across grain of **exotic timber and hardwood, single sided veneer, laminate boards and plastic coated materials**
- Extra fine finish

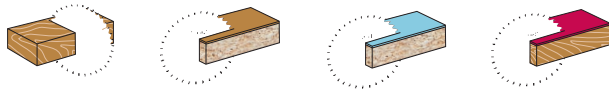

| Item | D | d | B/c | Z | Pin holes |
|----------------|-----|----|---------|-----|-----------|
| CD 150.03630 | 150 | 30 | 3,2/2,2 | 36 | |
| CD 200.04830 | 200 | 30 | 3,2/2,2 | 48 | |
| CDS250.06030 ♪ | 250 | 30 | 3,2/2,2 | 60 | PH02 |
| CDS250.06035 ♪ | 250 | 35 | 3,2/2,2 | 60 | PH02 |
| CD 280.06030 | 280 | 30 | 3,2/2,2 | 60 | PH02 |
| CDS300.07230 ♪ | 300 | 30 | 3,2/2,2 | 72 | PH02 |
| CDS300.07235 ♪ | 300 | 35 | 3,2/2,2 | 72 | PH02 |
| CD 315.07230 | 315 | 30 | 3,2/2,2 | 72 | PH02 |
| CDS350.08430 ♪ | 350 | 30 | 3,5/2,5 | 84 | PH02 |
| CDS350.08435 ♪ | 350 | 35 | 3,5/2,5 | 84 | PH02 |
| CDS400.09630 ♪ | 400 | 30 | 4,0/2,8 | 96 | PH02 |
| CD 450.10830 | 450 | 30 | 4,2/2,8 | 108 | PH01 |
| CD 500.12030 | 500 | 30 | 4,2/3,0 | 120 | PH01 |

ART. CE - CES

- For cutting across grain of **exotic and hardwood, for cutting double-sided veneer boards, single sided laminate boards, MDF and hard boards**
- Extra fine finish

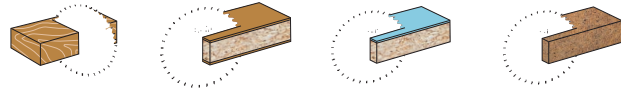

| Item | D | d | B/c | Z | Pin holes |
|----------------|-----|----|---------|-----|-----------|
| CE 150.04830 | 150 | 30 | 3,2/2,2 | 48 | |
| CE 180.05430 | 180 | 30 | 3,2/2,2 | 56 | |
| CE 200.06430 | 200 | 30 | 3,2/2,2 | 64 | |
| CES250.08030 ♪ | 250 | 30 | 3,2/2,2 | 80 | PH02 |
| CES300.09630 ♪ | 300 | 30 | 3,2/2,2 | 96 | PH02 |
| CES350.10830 ♪ | 350 | 30 | 3,5/2,5 | 112 | PH02 |
| CES400.12030 ♪ | 400 | 30 | 4,0/2,8 | 120 | PH02 |
| CE 450.13230 | 450 | 30 | 4,2/3,0 | 132 | PH01 |
| CE 500.14430 | 500 | 30 | 4,2/3,0 | 144 | PH01 |

RPM suggested referred to the blade diameter

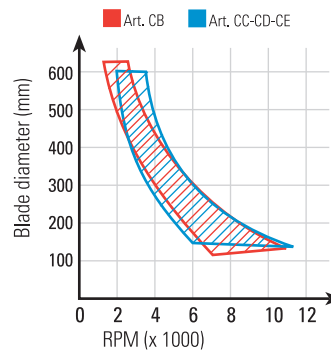

CONTACT US
 (+39) 0721 28950
 info@sistemiklein.com

visit our website
www.sistemiklein.com



HW MULTI PURPOSE SAWBLADES (THIN KERF)

ART. CF - CG - CH

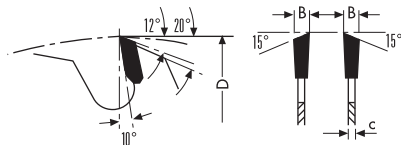

- WZ alternate teeth
- Suitable for table saws and panels saws
- With thin kerf for less friction cuts
- HW grade: HC10 (K10-C3)

Pin holes: PH02=2/7/42 + 2/9,5/46,5 + 2/10/60

ART. CF

- For cutting along and across grain of **softwood, rare woods and laminate boards**

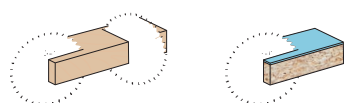

| Item | D | d | B/c | Z | Pin holes |
|-------------|-----|----|---------|----|-----------|
| CF150.02430 | 150 | 30 | 2,2/1,6 | 24 | |
| CF180.03030 | 180 | 30 | 2,2/1,6 | 30 | |
| CF200.03230 | 200 | 30 | 2,2/1,6 | 34 | |
| CF250.04030 | 250 | 30 | 2,2/1,6 | 40 | PH02 |
| CF300.04830 | 300 | 30 | 2,2/1,6 | 48 | PH02 |
| CF350.05430 | 350 | 30 | 2,4/1,8 | 54 | PH02 |

ART. CG

- For separating plastic up to 10 mm cutting height chipboards
- For cutting along and across grain of **fine wood, hardwood, single sided veneer boards and MDF**

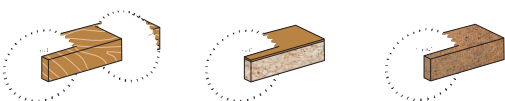

| Item | D | d | B/c | Z | Pin holes |
|-------------|-----|----|---------|-----|-----------|
| CG150.04830 | 150 | 30 | 2,2/1,6 | 48 | |
| CG180.05630 | 180 | 30 | 2,2/1,6 | 56 | |
| CG200.06430 | 200 | 30 | 2,2/1,6 | 64 | |
| CG250.08030 | 250 | 30 | 2,2/1,6 | 80 | PH02 |
| CG300.09630 | 300 | 30 | 2,2/1,6 | 96 | PH02 |
| CG350.10830 | 350 | 30 | 2,4/1,8 | 108 | PH02 |

ART. CH

- For cutting **single sided veneer boards plastic and aluminium profiles, plexiglass, pertinax, hard paper and print boards**

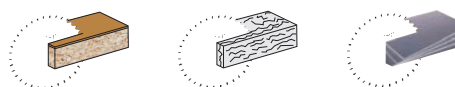

| Item | D | d | B/c | Z | Pin holes |
|-------------|-----|----|---------|-----|-----------|
| CH150.06030 | 150 | 30 | 2,2/1,6 | 60 | |
| CH200.08030 | 200 | 30 | 2,2/1,6 | 80 | |
| CH250.10030 | 250 | 30 | 2,2/1,6 | 100 | PH02 |
| CH300.12030 | 300 | 30 | 2,2/1,6 | 120 | PH02 |

RPM suggested referred to the blade diameter

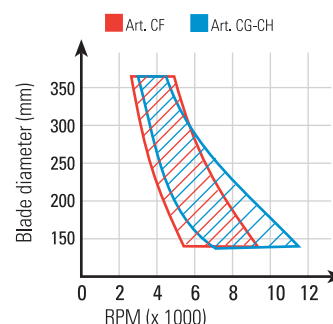

HW MULTI PURPOSE CIRCULAR SAWBLADES

ART. DA

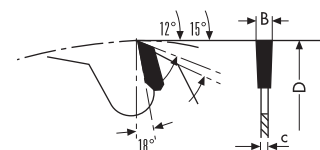

- FZ flat teeth
- For cutting along grain of all **natural woods** with large cutting heights
- For table saws
- ♪ = no-noise
- HW grade: HC10 (K10-C3)

Pin holes: PH02=2/7/42 + 2/9,5/46,5 + 2/10/60



| Item | D | d | B/c | Z | Pin holes |
|---------------|-----|---------------|---------|----|-----------|
| DA250.01830 | 250 | 30 | 3,2/2,2 | 20 | PH02 |
| DA300.02030 ♪ | 300 | 30 | 3,2/2,2 | 24 | PH02 |
| DA300.02070 ♪ | 300 | 70+ch (21x84) | 3,2/2,2 | 24 | |
| DA350.02430 ♪ | 350 | 30 | 3,5/2,5 | 28 | PH02 |

HW MULTI PURPOSE CIRCULAR SAWBLADES

ART. DC

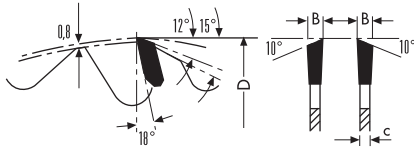

- WZ alternate top bevel teeth
- Anti-kickback design
- For cutting along and across grain of all **natural woods**, **wooden boarding materials**, also veneered or plastic coated one size
- For table saws
- = no-noise
- HW grade: HC10 (K10-C3)

Pin holes: **PH01**= 2/10/60 - **PH02**=2/7/42 + 2/9,5/46,5 + 2/10/60



| Item | D | d | B/c | Z | Pin holes |
|-------------|-----|----|---------|----|-----------|
| DC250.02430 | 250 | 30 | 3,2/2,2 | 24 | PH02 |
| DC300.02830 | 300 | 30 | 3,2/2,2 | 28 | PH02 |
| DC350.03230 | 350 | 30 | 3,5/2,5 | 32 | PH02 |
| DC400.03630 | 400 | 30 | 4,0/2,8 | 36 | PH02 |
| DC450.04030 | 450 | 30 | 4,2/2,8 | 40 | PH01 |
| DC500.04430 | 500 | 30 | 4,2/2,8 | 44 | PH01 |
| DC550.04430 | 550 | 30 | 4,2/3,0 | 48 | PH01 |
| DC600.05430 | 600 | 30 | 4,2/3,0 | 48 | PH01 |

RPM suggested referred to the blade diameter

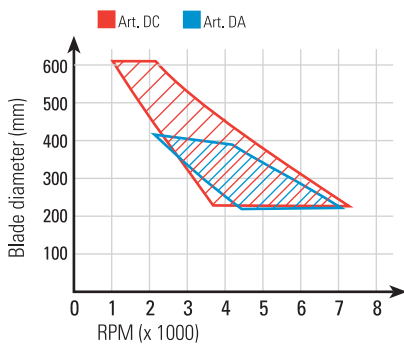

The anti-kickback design reduces the amount of wood each tooth takes away. The wood worker understands the dangers of kick back.

HW RADIAL ARM SAWBLADES

ART. FAS

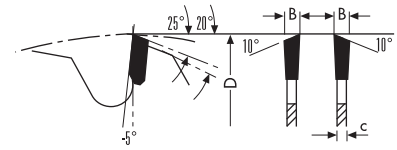

- WZ alternate top bevel teeth
- 5° negative hook angle
- For cutting across grain of **soft wood**, **hard wood**, **aluminium-wood profiles**, **plastic-wood profiles**
- For table saws
- = no-noise
- HW grade: HC10 (K10-C3)

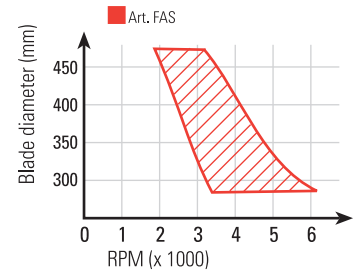

RPM suggested referred to the blade diameter

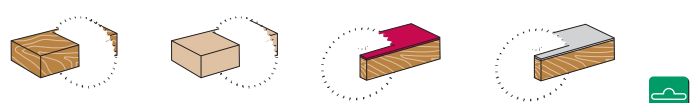

| Item | D | d | B/c | Z |
|--------------|-----|----|---------|----|
| FAS300.03630 | 300 | 30 | 4,4/2,8 | 36 |
| FAS350.04230 | 350 | 30 | 4,4/2,8 | 42 |
| FAS400.04830 | 400 | 30 | 4,4/2,8 | 48 |

HW TRIMMING AND SIZING SAWBLADES

ART. FB

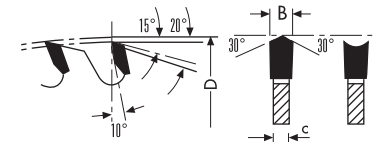

- HZ/DZ inverted "V" and hollow ground teeth
- For cutting boards with **synthetic resincoating**, **double sided veneer** and **laminated boards and plywood**
- For panel saws and table saws
- Extra finish and long cutting life
- HW grade: KCR06 (K01-C4)

Pin holes: **PH02**=2/7/42 + 2/9,5/46,5 + 2/10/60



| Item | D | d | B/c | Z | Pin holes |
|-------------|-----|----|---------|----|-----------|
| FB220.04230 | 220 | 30 | 3,2/2,2 | 42 | |
| FB253.04830 | 250 | 30 | 3,2/2,2 | 48 | PH02 |
| FB303.06030 | 300 | 30 | 3,2/2,2 | 60 | PH02 |
| FB350.07230 | 350 | 30 | 3,5/2,5 | 72 | PH02 |

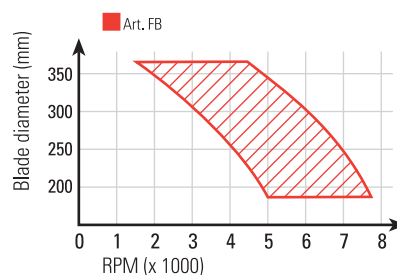

RPM suggested referred to the blade diameter

HW TRIMMING AND SIZING SAWBLADES

ART. FCS

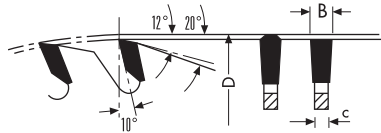

- FZ/TR triple chip teeth trapezoidal
- For table saws
- Ideal for working **ALUCOBOND®**
- For cutting **hardwoods, double sided veneer and laminate board, MDF, hard paper and thermoplastic boards**
- Extra finish and long cutting life
- = no-noise
- HW grade: **KCR06 (K01-C4)**

Pin holes: **PH02=2/7/42 + 2/9,5/46,5 + 2/10/60**

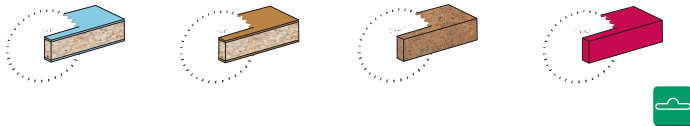

| Item | D | d | B/c | Z | Pin holes |
|--------------|-----|----|---------|-----|-----------|
| FCS250.06030 | 250 | 30 | 3,2/2,2 | 60 | PH02 |
| FCS250.08030 | 250 | 30 | 3,2/2,2 | 80 | PH02 |
| FCS300.07230 | 300 | 30 | 3,2/2,2 | 72 | PH02 |
| FCS300.09630 | 300 | 30 | 3,2/2,2 | 96 | PH02 |
| FCS350.08430 | 350 | 30 | 3,5/2,5 | 84 | PH02 |
| FCS350.11230 | 350 | 30 | 3,5/2,5 | 112 | PH02 |

RPM suggested referred to the blade diameter

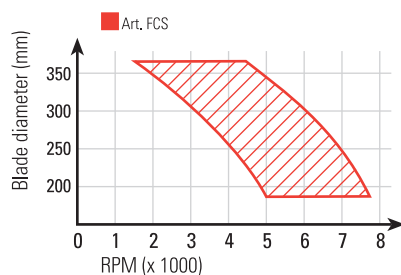

HW TRIMMING AND SIZING SAWBLADES "EXTRA CUT"

ART. FCT

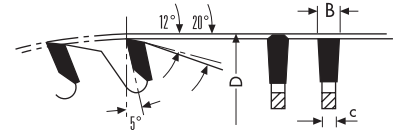

Xtra
cut

- FZ/TR triple chip teeth trapezoidal
- For cutting **hardwoods, double sided veneer and laminate board, MDF, hard paper and thermoplastic boards**
- Ideal for working **ALUCOBOND®**
- For table saws
- Extra finish and long cutting life
- = **no-noise and less vibration thanks to a special synthetic resin filled in the slots to increase the stability and reduce vibrations**
- HW grade: **KCR06 (K01-C4)**

Pin holes: **PH02=2/7/42 + 2/9,5/46,5 + 2/10/60**

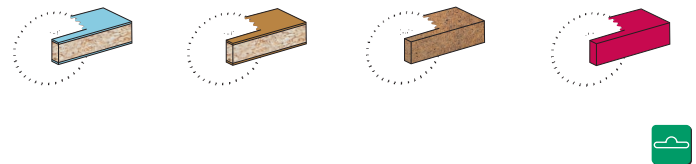

| Item | D | d | B/c | Z | Pin holes |
|-------------------------|-----|----|---------|-----|-----------|
| FCT250.06030 NEW | 250 | 30 | 3,2/2,2 | 60 | PH02 |
| FCT250.08030 NEW | 250 | 30 | 3,2/2,2 | 80 | PH02 |
| FCT300.07230 NEW | 300 | 30 | 3,2/2,2 | 72 | PH02 |
| FCT300.09630 NEW | 300 | 30 | 3,2/2,2 | 96 | PH02 |
| FCT350.08430 NEW | 350 | 30 | 3,5/2,5 | 84 | PH02 |
| FCT350.11230 NEW | 350 | 30 | 3,5/2,5 | 112 | PH02 |

Xtra
cut

A NEW LEVEL OF CUTTING WITH SPECIAL SYNTHETIC RESIN FILLED IN THE SLOTS TO INCREASE THE STABILITY AND REDUCE VIBRATIONS

- **LOW NOISE**
- **NO VIBRATION**
- **BETTER FINISHING**
- **LONGER LIFE**

Some tips for working with multi-ripping saws

A) When operating with a multi-rip saw the use of shoulder saw blades is very important (Items FG). Positioned as the first blade on the machine side they allow, especially during heavy-duty processing or working uneven timber, that the forces have a proper distribution.

B) The use of rakers is highly recommended to avoid the saw blade rubbing on the wood, causing overheating and friction which can damage the saw blades.

C) If the machine spindle has only one keyway it is highly recommended not to use saw blades having two to avoid any unbalanced coupling.

D) Keyways of the saw blades and machine spindle are best coupled when they have the same dimensions.

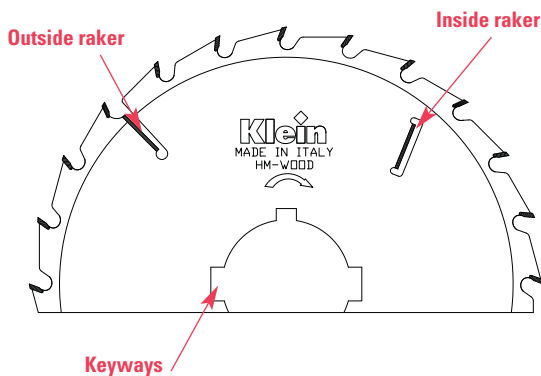

HW MULTIRIP SAWBLADES WITHOUT RAKERS

ART. FE

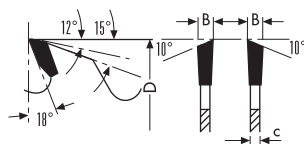

- WZ alternate top bevel teeth
- For cutting along grain of **softwood, hardwood and exotic timber**
- For multi blades saws
- HW grade: HC10 (K10-C3)



| Item | D | d+keyways | B/c | Z |
|-------------|-----|---------------|---------|----|
| FE300.02870 | 300 | 70+ch (21x84) | 3,2/2,2 | 24 |
| FE300.02880 | 300 | 80+ch (13x90) | 3,2/2,2 | 24 |
| FE350.03270 | 350 | 70+ch (21x84) | 3,5/2,5 | 28 |

HW SHOULDER RIP SAWBLADES WITH RAKERS

ART. FG

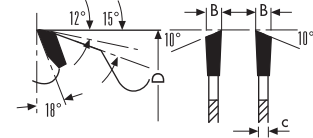

- WZ alternate teeth
- With HW rakers for better result in cutting along grain of hard wood and rare wood
- For sizing and trimming
- For multi blades saws
- HW grade: HC10 (K10-C3)



| Item | D | d+keyways | B/c | Z | L max |
|-------------|-----|---------------|---------|--------|-------|
| FG300.02470 | 300 | 70+ch (21x84) | 4,0/2,8 | 24+2+2 | 80 |
| FG300.02480 | 300 | 80+ch (13x90) | 4,0/2,8 | 24+2+2 | 80 |
| FG301.02470 | 300 | 70+ch (21x84) | 5,2/3,6 | 24+2+2 | 80 |
| FG301.02475 | 300 | 75+ch (21x91) | 5,2/3,6 | 24+2+2 | 80 |
| FG301.02480 | 300 | 80+ch (13x90) | 5,2/3,6 | 24+2+2 | 80 |
| FG320.02480 | 320 | 80+ch (13x90) | 4,0/2,8 | 24+2+2 | 90 |
| FG350.02470 | 350 | 70+ch (21x84) | 4,2/2,8 | 24+2+4 | 105 |
| FG350.02475 | 350 | 75+ch (21x91) | 4,2/2,8 | 24+2+4 | 105 |
| FG350.02480 | 350 | 80+ch (14x92) | 4,2/2,8 | 24+2+4 | 105 |
| FG351.02470 | 350 | 70+ch (21x84) | 4,5/3,2 | 24+2+2 | 105 |
| FG351.02475 | 350 | 75+ch (21x91) | 4,5/3,2 | 24+2+4 | 105 |
| FG351.02480 | 350 | 80+ch (14x92) | 4,5/3,2 | 24+2+4 | 105 |
| FG352.02470 | 350 | 70+ch (21x84) | 5,2/3,6 | 24+2+4 | 105 |
| FG352.02475 | 350 | 75+ch (21x91) | 5,2/3,6 | 24+2+4 | 105 |
| FG352.02480 | 350 | 80+ch (14x92) | 5,2/3,6 | 24+2+4 | 105 |

RPM suggested referred to the blade diameter

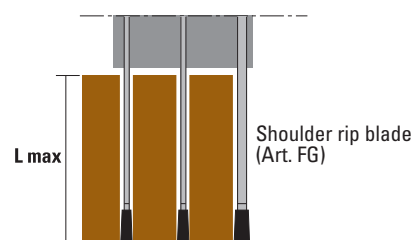
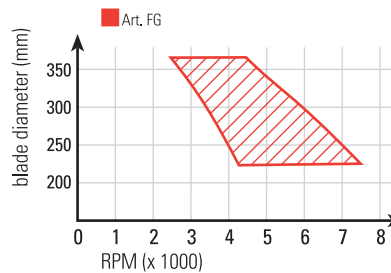

Lmax= Max cutting length

HW MULTIRIP SAWBLADES WITH RAKERS

ART. FH

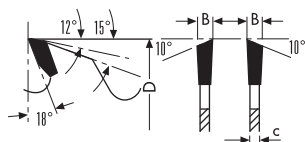

- **WZ** alternate top bevel teeth
- With HW outside and inside rakers for better result in cutting
- For cutting along grain of **softwood and hardwood** dried at 15% humidity rate, **exotic timber and rare wood**
- HW grade: **HC10 (K10-C3)**



| Item | D | d+keyways | B/c | Z | L max |
|-------------|-----|---------------|---------|--------|-------|
| FH250.01830 | 250 | 30 | 3,2/2,2 | 20+2+2 | 65 |
| FH250.01860 | 250 | 60+ch (21x74) | 3,2/2,2 | 20+2+2 | 65 |
| FH250.01870 | 250 | 70+ch (21x84) | 3,2/2,2 | 20+2+2 | 65 |
| FH250.01880 | 250 | 80+ch (13x90) | 3,2/2,2 | 20+2+2 | 65 |
| FH280.02070 | 280 | 70+ch (21x84) | 3,2/2,2 | 24+2+2 | 65 |
| FH280.02080 | 280 | 80+ch (13x90) | 3,2/2,2 | 24+2+2 | 70 |

| | | | | | |
|-------------|-----|----------------|---------|--------|-----|
| FH300.02430 | 300 | 30 | 3,2/2,2 | 24+2+2 | 80 |
| FH300.02460 | 300 | 60+ch (21x74) | 3,2/2,2 | 24+2+2 | 80 |
| FH300.02470 | 300 | 70+ch (21x84) | 3,2/2,2 | 24+2+2 | 80 |
| FH300.02475 | 300 | 75+ch (21x91) | 3,2/2,2 | 24+2+2 | 80 |
| FH300.02480 | 300 | 80+ch (13x90) | 3,2/2,2 | 24+2+2 | 80 |
| FH320.02480 | 320 | 80+ch (13x90) | 3,5/2,5 | 24+2+2 | 90 |
| FH350.02475 | 350 | 75+ch (21x91) | 3,5/2,5 | 24+2+4 | 105 |
| FH350.02480 | 350 | 80+ch (14x92) | 3,5/2,5 | 24+2+4 | 105 |
| FH350.02490 | 350 | 90+ch (21x110) | 3,5/2,5 | 24+2+4 | 95 |
| FH350.02630 | 350 | 30 | 3,5/2,5 | 24+2+4 | 105 |
| FH350.02660 | 350 | 60+ch (21x74) | 3,5/2,5 | 24+2+4 | 105 |
| FH350.02870 | 350 | 70+ch (21x84) | 3,5/2,5 | 24+2+4 | 105 |

| | | | | | |
|-------------|-----|---------------|---------|--------|-----|
| FH400.02875 | 400 | 75+ch (21x91) | 4,0/2,8 | 28+2+4 | 120 |
| FH400.02880 | 400 | 80+ch (13x90) | 4,0/2,8 | 28+2+4 | 120 |
| FH400.03030 | 400 | 30 | 4,0/2,8 | 28+2+4 | 120 |
| FH400.03070 | 400 | 70+ch (21x84) | 4,0/2,8 | 28+2+4 | 120 |

| | | | | | |
|-------------|-----|----------------|---------|--------|-----|
| FH450.02430 | 450 | 30 | 4,6/3,2 | 24+2+4 | 135 |
| FH450.02470 | 450 | 70+ch (21x84) | 4,6/3,2 | 24+2+4 | 135 |
| FH450.02475 | 450 | 75+ch (21x91) | 4,6/3,2 | 24+2+4 | 135 |
| FH450.02480 | 450 | 80+ch (13x92) | 4,6/3,2 | 24+2+4 | 135 |
| FH450.02490 | 450 | 90+ch (21x110) | 4,6/3,2 | 24+2+4 | 135 |

| | | | | | |
|-------------|-----|----|---------|--------|-----|
| FH500.02630 | 500 | 30 | 4,6/3,2 | 26+2+6 | 175 |
|-------------|-----|----|---------|--------|-----|

RPM suggested referred to the blade diameter

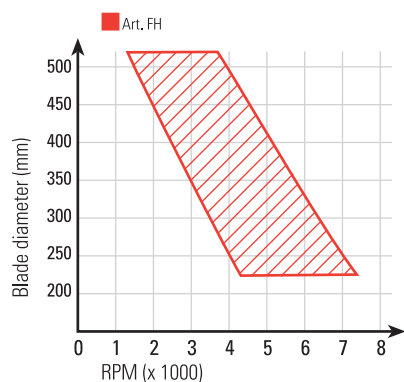

On request we can also supply multirip sawblades for "RAIMANN" machines.

HW MULTIRIP SAWBLADES WITH RAKERS (THIN KERF)

ART. FK

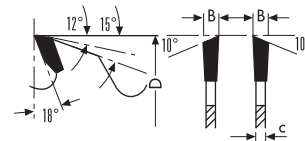

- **WZ** alternate top bevel teeth
- With HW outside and inside rakers for better result in cutting
- For cutting along grain of **softwood and hardwood** dried at 10%-15% humidity rate, **exotic timber and rare wood**
- Suitable for ripping where its thin body greatly reduces material wastes
- Ideal for processing **wooden floors and matchboardings**
- HW grade: **HC10 (K10-C3)**



| Item | D | d+keyways | B/c | Z | L max |
|-------------|-----|-----------|---------|------|-------|
| FK180.02135 | 180 | 35 | 2,5/1,8 | 21+3 | 30 |
| FK180.02140 | 180 | 40 | 2,5/1,8 | 21+3 | 30 |

| | | | | | |
|-------------|-----|----|---------|------|----|
| FK200.02135 | 200 | 35 | 2,5/1,8 | 21+3 | 35 |
| FK200.02140 | 200 | 40 | 2,5/1,8 | 21+3 | 35 |

| | | | | | |
|-------------|-----|---------------|---------|--------|----|
| FK250.02060 | 250 | 60+ch (21x74) | 2,7/1,8 | 20+2+2 | 50 |
| FK250.02070 | 250 | 70+ch (21x84) | 2,7/1,8 | 20+2+2 | 50 |
| FK250.02080 | 250 | 80+ch (13x90) | 2,7/1,8 | 20+2+2 | 50 |

| | | | | | |
|-------------|-----|---------------|---------|--------|----|
| FK300.02460 | 300 | 60+ch (21x74) | 2,7/1,8 | 24+2+2 | 60 |
| FK300.02470 | 300 | 70+ch (21x84) | 2,7/1,8 | 24+2+2 | 60 |
| FK300.02480 | 300 | 80+ch (13x90) | 2,7/1,8 | 24+2+2 | 60 |

RPM suggested referred to the blade diameter

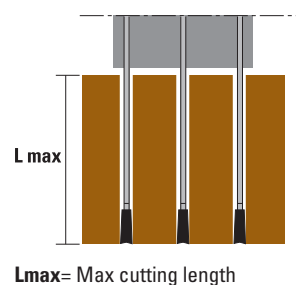
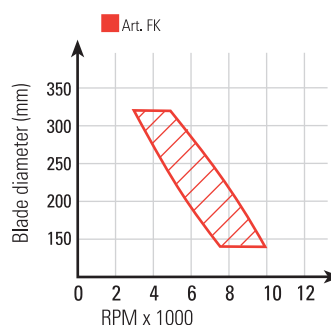

Pin holes for sizing sawblades:

Scale 1:1

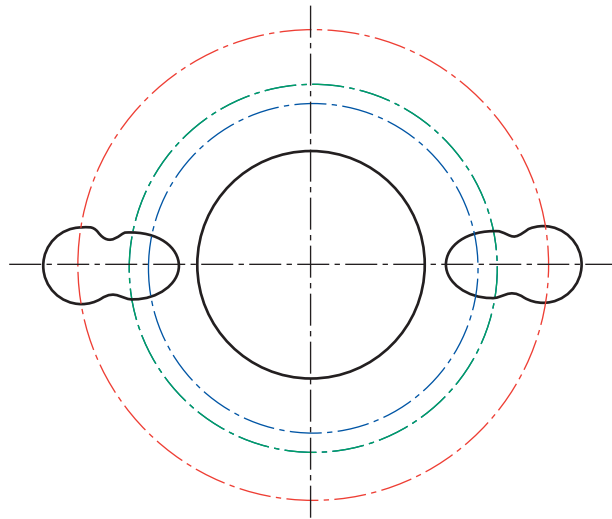

PH02

| Name | Nr of holes/diameter of holes/pitch circle diameter | Machine type |
|------|---|--------------|
| PH02 | 2/7/42 + 2/9,5/46,5 + 2/10/60 | Universal |

Scale 1:1

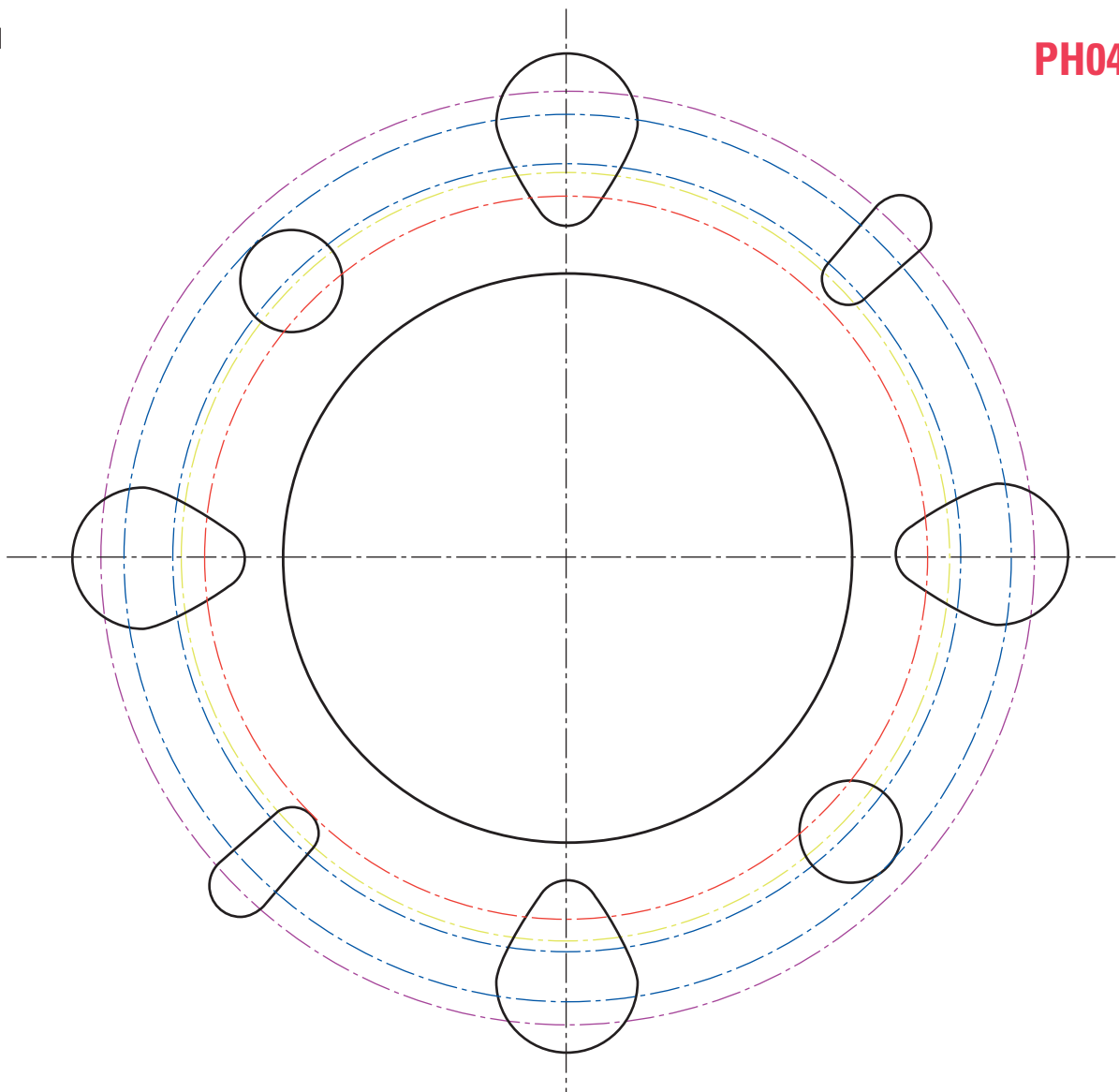

PH04

| Name | Nr of holes/diameter of holes/pitch circle diameter | Machine type |
|------|---|------------------------|
| PH04 | 2/14/110 + 2/7/110 + 4/9/100 + 4/19/120 + 2/9/130 | GABBIANI - SCM - SELCO |

Scale 1:1

PH05

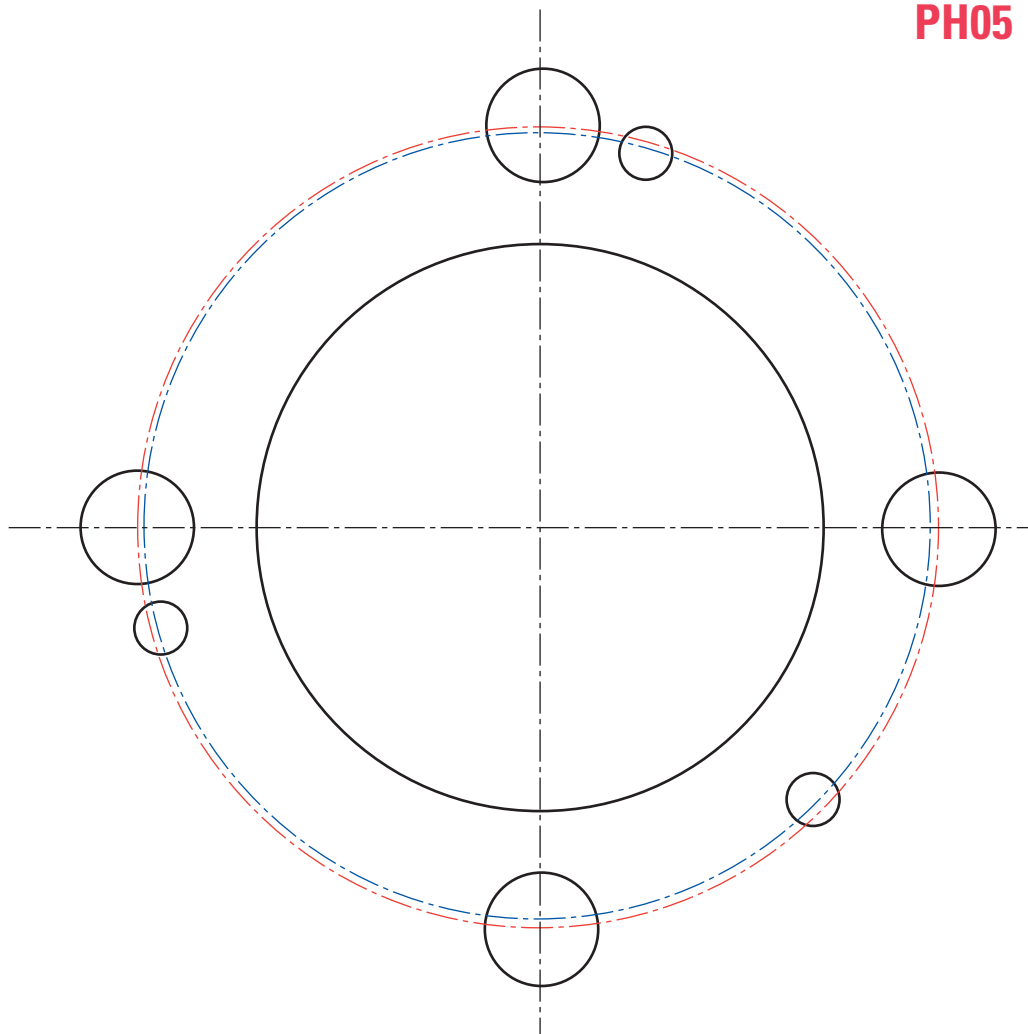

| Name | Nr of holes/diameter of holes/pitch circle diameter | Machine type |
|------|---|--------------------------|
| PH05 | 4/15/105 + 3/7/100 | GIBEN - HOMAG - MACMAZZA |

REFERENCE TABLE OF PANEL SIZING MACHINES

ANTHON: MAIN SAWBLADE

| Item | D | B | d | Z | MAT. |
|--------------|-----|---------|------|----------|------|
| HCS400.07260 | 400 | 4.4/3.2 | 60+2 | 72 FZ/TR | HW |
| HCS430.07260 | 430 | 4.4/3.2 | 60+2 | 72 FZ/TR | HW |
| HCS450.07260 | 450 | 4.4/3.2 | 60+2 | 72 FZ/TR | HW |
| HCS531.06060 | 530 | 5.8/4.0 | 60+2 | 60 FZ/TR | HW |

| | | | | | |
|--------------|-----|---------|------|----------|----|
| XHC400.07260 | 400 | 4.4/3.2 | 60+2 | 72 FZ/TR | DP |
|--------------|-----|---------|------|----------|----|

Pin holes 2/11/85

ANTHON: SCORING SAWBLADE

| Item | D | B | d | Z | MAT. |
|-------------|-----|---------|----|-----------|------|
| FI180.03620 | 180 | 4.3/5.5 | 20 | 36 KON/FZ | HW |
| FI183.03620 | 180 | 5.8/7.0 | 20 | 36 KON/FZ | HW |

| | | | | | |
|--------------|-----|---------|----|-----------|----|
| XFI180.03620 | 180 | 4.4/5.0 | 20 | 36 KON/FZ | DP |
| XFI182.03620 | 180 | 5.8/6.6 | 20 | 36 KON/FZ | DP |

GABBIANI: MAIN SAWBLADE

| Item | D | B | d | Z | MAT. |
|--------------|-----|---------|--------|----------|------|
| HCS300.06080 | 300 | 4.4/3.2 | 80+PH4 | 60 FZ/TR | HW |
| HCS300.07280 | 300 | 4.4/3.2 | 80+PH4 | 72 FZ/TR | HW |
| HCS350.05680 | 350 | 4.4/3.2 | 80+PH4 | 54 FZ/TR | HW |
| HCS350.07280 | 350 | 4.4/3.2 | 80+PH4 | 72 FZ/TR | HW |
| HCS351.07280 | 350 | 4.6/3.2 | 80+PH4 | 72 FZ/TR | HW |
| HCS355.07280 | 350 | 4.4/3.2 | 80+PH4 | 72 FZ/TR | HW |
| HCS380.07280 | 380 | 4.4/3.2 | 80+PH4 | 72 FZ/TR | HW |
| HCS400.06080 | 400 | 4.4/3.2 | 80+PH4 | 60 FZ/TR | HW |
| HCS400.07280 | 400 | 4.4/3.2 | 80+PH4 | 72 FZ/TR | HW |
| HCS401.07280 | 400 | 4.6/3.2 | 80+PH4 | 72 FZ/TR | HW |
| HCS420.07280 | 420 | 4.4/3.2 | 80+PH4 | 72 FZ/TR | HW |
| HCS450.07280 | 450 | 4.4/3.2 | 80+PH4 | 72 FZ/TR | HW |

| | | | | | |
|--------------|-----|---------|--------|-------|----|
| HBS350.05680 | 350 | 4.4/3.2 | 80+PH4 | 54 WZ | HW |
| HBS350.07280 | 350 | 4.4/3.2 | 80+PH4 | 72 WZ | HW |
| HBS400.03680 | 400 | 4.4/3.2 | 80+PH4 | 36 WZ | HW |
| HBS400.06080 | 400 | 4.4/3.2 | 80+PH4 | 60 WZ | HW |
| HBS400.07280 | 400 | 4.4/3.2 | 80+PH4 | 72 WZ | HW |
| HBS401.06080 | 400 | 4.6/3.2 | 80+PH4 | 60 WZ | HW |
| HBS450.03680 | 450 | 4.4/3.2 | 80+PH4 | 36 WZ | HW |
| HBS450.05480 | 450 | 4.4/3.2 | 80+PH4 | 54 WZ | HW |

| | | | | | |
|--------------|-----|---------|--------|----------|----|
| XHC350.07280 | 350 | 4.4/3.2 | 80+PH4 | 72 FZ/TR | DP |
| XHC400.07280 | 400 | 4.4/3.2 | 80+PH4 | 72 FZ/TR | DP |
| XHC450.07280 | 450 | 4.4/3.2 | 80+PH4 | 72 FZ/TR | DP |

Pin holes 2/14/110+2/7/110+4/9/100

GABBIANI: SCORING SAWBLADE

| Item | D | B | d | Z | MAT. |
|-------------|-----|---------|------|-----------|------|
| FI161.03655 | 160 | 4.3/5.5 | 55+3 | 36 KON/FZ | HW |
| FI162.03655 | 160 | 4.5/5.7 | 55+3 | 36 KON/FZ | HW |
| FI163.03655 | 160 | 4.7/6.0 | 55+3 | 36 KON/FZ | HW |
| FI200.03680 | 200 | 4.3/5.5 | 80 | 36 KON/FZ | HW |

Pin holes 2/14/110

| | | | | | |
|--------------|-----|---------|------|-----------|----|
| XFI160.03655 | 160 | 4.4/5.0 | 55+3 | 36 KON/FZ | DP |
|--------------|-----|---------|------|-----------|----|

Pin holes 3/7/66

GIBEN: MAIN SAWBLADE

| Item | D | B | d | Z | MAT. |
|--------------|-----|---------|------|----------|------|
| HCS320.06050 | 320 | 4.4/3.2 | 50+8 | 60 FZ/TR | HW |
| HCS320.07250 | 320 | 4.4/3.2 | 50+8 | 72 FZ/TR | HW |
| HCS330.06050 | 330 | 4.4/3.2 | 50+8 | 60 FZ/TR | HW |
| HCS350.07250 | 350 | 4.4/3.2 | 50+8 | 72 FZ/TR | HW |
| HCS360.07250 | 360 | 4.4/3.2 | 50+8 | 72 FZ/TR | HW |
| HCS380.07250 | 380 | 4.4/3.2 | 50+8 | 72 FZ/TR | HW |

| | | | | | |
|--------------|-----|---------|------|-------|----|
| HBS320.03650 | 320 | 4.4/3.2 | 50+8 | 36 WZ | HW |
|--------------|-----|---------|------|-------|----|

| | | | | | |
|--------------|-----|---------|------|----------|----|
| XHC320.06050 | 320 | 4.4/3.2 | 50+8 | 60 FZ/TR | DP |
| XHC330.06050 | 330 | 4.4/3.2 | 50+8 | 60 FZ/TR | DP |
| XHC350.07250 | 350 | 4.4/3.2 | 50+8 | 72 FZ/TR | DP |
| XHC360.07250 | 360 | 4.4/3.2 | 50+8 | 72 FZ/TR | DP |

Pin holes 6/12.5/80+2/12.5/80

| | | | | | |
|--------------|-----|---------|------|----------|----|
| HCS320.07275 | 320 | 4.4/3.2 | 75+3 | 72 FZ/TR | HW |
|--------------|-----|---------|------|----------|----|

Pin holes 3/13/95

| | | | | | |
|--------------|-----|---------|--------|----------|----|
| HCS350.05675 | 350 | 4.4/3.2 | 75+PH5 | 54 FZ/TR | HW |
| HCS350.07275 | 350 | 4.4/3.2 | 75+PH5 | 72 FZ/TR | HW |
| HCS355.07275 | 355 | 4.4/3.2 | 75+PH5 | 72 FZ/TR | HW |
| HCS380.07250 | 380 | 4.4/3.2 | 75+PH5 | 72 FZ/TR | HW |
| HCS400.06075 | 400 | 4.4/3.2 | 75+4 | 60 FZ/TR | HW |
| HCS400.07275 | 400 | 4.4/3.2 | 75+4 | 72 FZ/TR | HW |
| HCS430.07275 | 430 | 4.4/3.2 | 75+4 | 72 FZ/TR | HW |
| HCS430.09675 | 430 | 4.4/3.2 | 75+4 | 96 FZ/TR | HW |
| HCS470.07275 | 470 | 4.4/3.2 | 75+4 | 72 FZ/TR | HW |
| HCS470.09675 | 470 | 4.4/3.2 | 75+4 | 96 FZ/TR | HW |

| | | | | | |
|--------------|-----|---------|--------|-------|----|
| HBS350.05675 | 350 | 4.4/3.2 | 75+PH5 | 54 WZ | HW |
| HBS350.07275 | 350 | 4.4/3.2 | 75+PH5 | 72 WZ | HW |
| HBS400.06075 | 400 | 4.4/3.2 | 75+4 | 60 WZ | HW |
| HBS400.07275 | 400 | 4.4/3.2 | 75+4 | 72 WZ | HW |
| HBS401.06075 | 400 | 4.6/3.2 | 75+4 | 60 WZ | HW |

| | | | | | |
|--------------|-----|---------|------|----------|----|
| XHC350.07275 | 350 | 4.4/3.2 | 75+4 | 72 FZ/TR | DP |
| XHC400.07275 | 400 | 4.4/3.2 | 75+4 | 72 FZ/TR | DP |
| XHC430.07275 | 430 | 4.4/3.2 | 75+4 | 72 FZ/TR | DP |
| XHC470.07275 | 470 | 4.4/3.2 | 75+4 | 72 FZ/TR | DP |

Pin holes 4/15/105

| | | | | | |
|--------------|-----|---------|-----|----------|----|
| HCS550.07299 | 550 | 5.2/3.5 | 100 | 72 FZ/TR | HW |
| HCS565.07299 | 565 | 5.2/3.5 | 100 | 72 FZ/TR | HW |

GIBEN: SCORING SAWBLADE

| Item | D | B | d | Z | MAT. |
|--------------|-----|---------|------|--------------|------|
| FI127.02045 | 125 | 4.0/4.8 | 45 | 20+20 KON/FZ | HW |
| FI126.02445 | 125 | 4.3/5.5 | 45 | 24 KON/FZ | HW |
| XFI126.02045 | 125 | 4.0/4.8 | 45 | 20+20 KON/FZ | DP |
| FI161.03645 | 160 | 4.3/5.5 | 45+3 | 36 KON/FZ | HW |
| FI162.03645 | 160 | 4.5/5.7 | 45+3 | 36 KON/FZ | HW |

| | | | | | |
|--------------|-----|---------|------|-----------|----|
| XFI160.03645 | 160 | 4.4/5.0 | 45+3 | 36 KON/FZ | DP |
|--------------|-----|---------|------|-----------|----|

Pin holes 3/11/70

| | | | | | |
|-------------|-----|---------|------|-----------|----|
| FI180.03650 | 180 | 4.3/5.5 | 50+3 | 44 KON/FZ | HW |
|-------------|-----|---------|------|-----------|----|

| | | | | | |
|--------------|-----|---------|------|-----------|----|
| XFI180.04450 | 180 | 4.4/5.0 | 50+3 | 44 KON/FZ | DP |
|--------------|-----|---------|------|-----------|----|

Pin holes 3/12.5/80

| | | | | | |
|-------------|-----|---------|----|-----------|----|
| FI182.03655 | 180 | 5.0/6.2 | 55 | 36 KON/FZ | HW |
|-------------|-----|---------|----|-----------|----|

| | | | | | |
|-------------|-----|---------|------|-----------|----|
| FI215.04250 | 215 | 4.3/5.5 | 50+3 | 42 KON/FZ | HW |
| FI216.04250 | 215 | 4.5/5.7 | 50+3 | 42 KON/FZ | HW |
| FI300.04850 | 300 | 4.3/5.5 | 50+3 | 48 KON/FZ | HW |
| FI301.04850 | 300 | 4.5/5.7 | 50+3 | 48 KON/FZ | HW |

| | | | | | |
|--------------|-----|---------|------|-----------|----|
| XFI215.04250 | 215 | 4.4/5.0 | 50+3 | 42 KON/FZ | DP |
|--------------|-----|---------|------|-----------|----|

Pin holes 3/15/80

HOLZMA: MAIN SAWBLADE

| Item | D | B | d | Z | MAT. |
|-----------------------------|-----|---------|------|----------|------|
| HCS350.07260 | 350 | 4.4/3.2 | 60+2 | 72 FZ/TR | HW |
| HCS380.07260 | 380 | 4.4/3.2 | 60+2 | 72 FZ/TR | HW |
| HCS381.06050 | 380 | 4.8/3.5 | 60+2 | 72 FZ/TR | HW |
| HCS381.08460 | 380 | 4.8/3.5 | 60+2 | 84 FZ/TR | HW |
| XHC350.07260 | 350 | 4.4/3.2 | 60+2 | 72 FZ/TR | DP |
| XHC380.07260 | 380 | 4.8/3.5 | 60+2 | 72 FZ/TR | DP |
| Pin holes 2/14/100 | | | | | |
| HCS402.07260 | 400 | 4.8/3.5 | 60+4 | 72 FZ/TR | HW |
| XHC401.07260 | 400 | 4.8/3.5 | 60+4 | 72 FZ/TR | DP |
| Pin holes 2/14/100+2/14/125 | | | | | |
| HCS421.07260 | 420 | 4.8/3.5 | 60+2 | 72 FZ/TR | HW |
| HCS450.07260 | 450 | 4.4/3.2 | 60+2 | 72 FZ/TR | HW |
| HCS452.07260 | 450 | 4.8/3.5 | 60+2 | 72 FZ/TR | HW |
| XHC420.07260 | 420 | 4.8/3.5 | 60+2 | 72 FZ/TR | DP |
| XHC451.07260 | 450 | 4.8/3.5 | 60+2 | 72 FZ/TR | DP |
| Pin holes 2/14/125 | | | | | |
| HCS500.06060 | 500 | 4.8/3.5 | 60+2 | 60 FZ/TR | HW |
| HCS500.07260 | 500 | 4.8/3.5 | 60+2 | 72 FZ/TR | HW |
| XHC500.07260 | 500 | 4.8/3.5 | 60+2 | 72 FZ/TR | DP |
| Pin holes 2/11/115 | | | | | |
| HCS481.07260 | 480 | 4.8/3.5 | 60+4 | 72 FZ/TR | HW |
| HCS520.06060 | 520 | 4.8/3.5 | 60+4 | 60 FZ/TR | HW |
| HCS540.08460 | 540 | 4.8/3.5 | 60+4 | 84 FZ/TR | HW |
| HCS541.06060 | 540 | 5.8/4.0 | 60+4 | 60 FZ/TR | HW |
| HCS570.06060 | 570 | 4.8/3.5 | 60+4 | 60 FZ/TR | HW |
| HCS571.09660 | 570 | 5.8/4.0 | 60+4 | 96 FZ/TR | HW |
| HCS600.06060 | 600 | 5.8/4.0 | 60+4 | 60 FZ/TR | HW |
| HCS600.07260 | 600 | 5.8/4.0 | 60+4 | 72 FZ/TR | HW |
| XHC481.07260 | 480 | 4.8/3.5 | 60+4 | 72 FZ/TR | DP |
| XHC520.06060 | 520 | 4.8/3.5 | 60+4 | 60 FZ/TR | DP |
| Pin holes 2/11/115+2/19/120 | | | | | |

GIBEN: SCORING SAWBLADE

| Item | D | B | d | Z | MAT. |
|--------------|-----|---------|----|-----------|------|
| FI180.03645 | 180 | 4.3/5.5 | 45 | 36 KON/FZ | HW |
| FI181.03645 | 180 | 4.7/6.0 | 45 | 36 KON/FZ | HW |
| FI200.03645 | 200 | 4.3/5.5 | 45 | 36 KON/FZ | HW |
| FI201.03645 | 200 | 4.7/6.0 | 45 | 36 KON/FZ | HW |
| FI204.03645 | 200 | 5.8/7.0 | 45 | 36 KON/FZ | HW |
| XFI180.03645 | 180 | 4.4/5.0 | 45 | 36 KON/FZ | DP |
| XFI181.03645 | 180 | 4.8/5.6 | 45 | 36 KON/FZ | DP |
| XFI200.03645 | 200 | 4.4/5.0 | 45 | 36 KON/FZ | DP |
| XFI201.03645 | 200 | 4.8/5.6 | 45 | 36 KON/FZ | DP |
| XFI203.03645 | 200 | 5.8/6.6 | 45 | 36 KON/FZ | DP |

HOMAG: MAIN SAWBLADE

| Item | D | B | d | Z | MAT. |
|--------------|-----|---------|----|----------|------|
| HCS300.06075 | 300 | 4.4/3.2 | 75 | 60 FZ/TR | HW |
| HCS350.05675 | 350 | 4.4/3.2 | 75 | 54 FZ/TR | HW |
| HCS350.07275 | 350 | 4.4/3.2 | 75 | 72 FZ/TR | HW |
| HCS355.07275 | 355 | 4.4/3.2 | 75 | 72 FZ/TR | HW |
| HCS400.06075 | 400 | 4.4/3.2 | 75 | 60 FZ/TR | HW |
| HCS400.07275 | 400 | 4.4/3.2 | 75 | 72 FZ/TR | HW |
| HBS350.05675 | 350 | 4.4/3.2 | 75 | 54 WZ | HW |
| HBS350.07275 | 350 | 4.4/3.2 | 75 | 72 WZ | HW |
| HBS400.06075 | 400 | 4.4/3.2 | 75 | 60 WZ | HW |
| HBS400.07275 | 400 | 4.4/3.2 | 75 | 72 WZ | HW |
| HBS401.06075 | 400 | 4.6/3.2 | 75 | 60 WZ | HW |
| XHC350.07275 | 350 | 4.4/3.2 | 75 | 72 FZ/TR | DP |
| XHC400.07275 | 400 | 4.4/3.2 | 75 | 72 FZ/TR | DP |

HOMAG: SCORING SAWBLADE

| Item | D | B | d | Z | MAT. |
|--------------|-----|---------|----|-----------|------|
| FI126.02445 | 125 | 4.3/5.5 | 45 | 24 KON/FZ | HW |
| FI151.03645 | 150 | 4.3/5.5 | 45 | 36 KON/FZ | HW |
| FI180.03645 | 180 | 4.3/5.5 | 45 | 36 KON/FZ | HW |
| FI200.03645 | 200 | 4.3/5.5 | 45 | 36 KON/FZ | HW |
| XFI160.03645 | 160 | 4.4/5.0 | 45 | 36 KON/FZ | DP |
| XFI180.03645 | 180 | 4.4/5.0 | 45 | 36 KON/FZ | DP |
| XFI200.03645 | 200 | 4.4/5.0 | 45 | 36 KON/FZ | DP |

MACMAZZA: MAIN SAWBLADE

| Item | D | B | d | Z | MAT. |
|--------------|-----|---------|------|----------|------|
| HCS350.05675 | 350 | 4.4/3.2 | 75+3 | 54 FZ/TR | HW |
| HCS350.07275 | 350 | 4.4/3.2 | 75+3 | 72 FZ/TR | HW |
| HCS355.07275 | 355 | 4.4/3.2 | 75+3 | 72 FZ/TR | HW |
| HCS380.07275 | 380 | 4.4/3.2 | 75+3 | 72 FZ/TR | HW |
| HBS350.05675 | 350 | 4.4/3.2 | 75+3 | 54 WZ | HW |
| HBS350.07275 | 350 | 4.4/3.2 | 75+3 | 72WZ | HW |

| | | | | | |
|-------------------|-----|---------|------|----------|----|
| XHC350.07275 | 350 | 4.4/3.2 | 75+3 | 72 FZ/TR | DP |
| Pin holes 3/7/100 | | | | | |

| | | | | | |
|-------------------|-----|---------|------|----------|----|
| HCS450.07275 | 450 | 4.4/3.2 | 75+3 | 72 FZ/TR | HW |
| Pin holes 3/7/120 | | | | | |

MACMAZZA: SCORING SAWBLADE

| Articolo | D | B | d | Z | MAT. |
|------------------|-----|---------|------|-----------|------|
| FI161.03655 | 160 | 4.3/5.5 | 55+3 | 36 KON/FZ | HW |
| FI280.04855 | 280 | 4.5/5.6 | 55+3 | 48 KON/FZ | HW |
| XFI160.03645 | 160 | 4.4/5.0 | 55+3 | 36 KON/FZ | DP |
| Pin holes 3/6/84 | | | | | |

MAYER: MAIN SAWBLADE

| Item | D | B | d | Z | MAT. |
|--------------|-----|---------|--------|----------|------|
| HCS300.06030 | 300 | 4.4/3.2 | 30+PH1 | 60 FZ/TR | HW |
| HCS300.07230 | 300 | 4.4/3.2 | 30+PH1 | 72 FZ/TR | HW |
| HCS350.05630 | 350 | 4.4/3.2 | 30+PH1 | 54 FZ/TR | HW |
| HCS350.07230 | 350 | 4.4/3.2 | 30+PH1 | 72 FZ/TR | HW |
| HCS400.06030 | 400 | 4.4/3.2 | 30+2 | 60 FZ/TR | HW |
| HCS400.07230 | 400 | 4.4/3.2 | 30+2 | 72 FZ/TR | HW |

| | | | | | |
|--------------|-----|---------|--------|-----|----|
| HBS300.04830 | 300 | 4.4/3.2 | 30+PH1 | 48A | HW |
| HBS300.06030 | 300 | 4.4/3.2 | 30+PH1 | 60A | HW |
| HBS300.07230 | 300 | 4.4/3.2 | 30+PH1 | 72A | HW |
| HBS350.05430 | 350 | 4.4/3.2 | 30+PH1 | 54A | HW |
| HBS350.07230 | 350 | 4.4/3.2 | 30+PH1 | 72A | HW |
| HBS400.06030 | 400 | 4.4/3.2 | 30+2 | 60A | HW |
| HBS400.07230 | 400 | 4.4/3.2 | 30+2 | 72A | HW |

| | | | | | |
|--------------|-----|---------|--------|----------|----|
| XHC300.06030 | 300 | 4.4/3.2 | 30+PH1 | 60 FZ/TR | DP |
| XHC350.07230 | 350 | 4.4/3.2 | 30+PH1 | 72 FZ/TR | DP |
| XHC400.07230 | 400 | 4.4/3.2 | 30+2 | 72 FZ/TR | DP |

Pin holes 2/10/60

MAYER: SCORING SAWBLADE

| Item | D | B | d | Z | MAT. |
|-------------|-----|---------|----|--------------|------|
| FL127.02045 | 125 | 4.0/4.8 | 45 | 20+20 KON/FZ | HW |
| FI126.02445 | 125 | 4.3/5.5 | 45 | 24 KON/FZ | HW |
| FI151.03630 | 150 | 4.3/5.5 | 30 | 36 KON/FZ | HW |

| | | | | | |
|--------------|-----|---------|----|--------------|----|
| XFI126.02045 | 125 | 4.0/4.8 | 45 | 20+20 KON/FZ | DP |
|--------------|-----|---------|----|--------------|----|

PANHANS: MAIN SAWBLADE

| Item | D | B | d | Z | MAT. |
|--------------|-----|---------|--------|----------|------|
| HCS300.06030 | 300 | 4.4/3.2 | 30+PH1 | 60 FZ/TR | HW |
| HCS300.07230 | 300 | 4.4/3.2 | 30+PH1 | 72 FZ/TR | HW |
| HCS350.05430 | 350 | 4.4/3.2 | 30+PH1 | 54 FZ/TR | HW |
| HCS350.07230 | 350 | 4.4/3.2 | 30+PH1 | 72 FZ/TR | HW |
| HCS400.06030 | 400 | 4.4/3.2 | 30+PH1 | 60 FZ/TR | HW |
| HCS400.07230 | 400 | 4.4/3.2 | 30+PH1 | 72 FZ/TR | HW |
| HCS450.07230 | 450 | 4.4/3.2 | 30+2 | 72 FZ/TR | HW |

| | | | | | |
|--------------|-----|---------|--------|-------|----|
| HBS300.04830 | 300 | 4.4/3.2 | 30+PH1 | 48 WZ | HW |
| HBS300.06030 | 300 | 4.4/3.2 | 30+PH1 | 60 WZ | HW |
| HBS300.07230 | 300 | 4.4/3.2 | 30+PH1 | 72 WZ | HW |
| HBS350.05430 | 350 | 4.4/3.2 | 30+PH1 | 54 WZ | HW |
| HBS350.07230 | 350 | 4.4/3.2 | 30+PH1 | 72 WZ | HW |
| HBS400.06030 | 400 | 4.4/3.2 | 30+2 | 60 WZ | HW |
| HBS400.07230 | 400 | 4.4/3.2 | 30+2 | 72 WZ | HW |
| HBS450.05430 | 450 | 4.4/3.2 | 30+2 | 54 WZ | HW |
| HBS450.07230 | 450 | 4.4/3.2 | 30+2 | 72 WZ | HW |

| | | | | | |
|--------------|-----|---------|--------|----------|----|
| XHC300.06030 | 300 | 4.4/3.2 | 30+PH1 | 60 FZ/TR | DP |
| XHC350.07230 | 350 | 4.4/3.2 | 30+PH1 | 72 FZ/TR | DP |
| XHC400.07230 | 400 | 4.4/3.2 | 30+2 | 72 FZ/TR | DP |

Pin holes 2/10/60

PANHANS: SCORING SAWBLADE

| Item | D | B | d | Z | MAT. |
|-------------|-----|---------|----|-----------|------|
| FI126.02420 | 125 | 4.3/5.5 | 20 | 24 KON/FZ | HW |
| FI180.03630 | 180 | 4.3/5.5 | 30 | 36 KON/FZ | HW |
| FI200.03630 | 200 | 4.3/5.5 | 30 | 36 KON/FZ | HW |

| | | | | | |
|--------------|-----|---------|----|-----------|----|
| XFI200.03630 | 200 | 4.4/5.0 | 30 | 36 KON/FZ | DP |
|--------------|-----|---------|----|-----------|----|

SCHELLING: MAIN SAWBLADE

| Item | D | B | d | Z | MAT. |
|--------------|-----|---------|--------|----------|------|
| HCS350.05630 | 350 | 4.4/3.2 | 30+PH1 | 54 FZ/TR | HW |
| HCS350.07230 | 350 | 4.4/3.2 | 30+PH1 | 72 FZ/TR | HW |
| HCS370.07230 | 370 | 4.4/3.2 | 30+2 | 72 FZ/TR | HW |
| HCS400.06030 | 400 | 4.4/3.2 | 30+PH1 | 60 FZ/TR | HW |
| HCS400.07230 | 400 | 4.4/3.2 | 30+PH1 | 72 FZ/TR | HW |

| | | | | | |
|--------------|-----|---------|--------|-------|----|
| HBS350.05430 | 350 | 4.4/3.2 | 30+PH1 | 54 WZ | HW |
| HBS350.07230 | 350 | 4.4/3.2 | 30+PH1 | 72 WZ | HW |
| HBS400.06030 | 400 | 4.4/3.2 | 30+2 | 60 WZ | HW |
| HBS400.07230 | 400 | 4.4/3.2 | 30+2 | 72 WZ | HW |

| | | | | | |
|--------------|-----|---------|--------|----------|----|
| XHC300.06030 | 300 | 4.4/3.2 | 30+PH1 | 60 FZ/TR | DP |
| XHC350.07230 | 350 | 4.4/3.2 | 30+PH1 | 72 FZ/TR | DP |
| XHC370.07230 | 370 | 4.4/3.2 | 30+2 | 72 FZ/TR | DP |
| XHC400.07230 | 400 | 4.4/3.2 | 30+2 | 72 FZ/TR | DP |

Pin holes 2/10/60

| | | | | | |
|--------------|-----|---------|------|----------|----|
| HCS450.07230 | 450 | 4.4/3.2 | 30+2 | 72 FZ/TR | HW |
| HCS460.07230 | 460 | 4.4/3.2 | 30+2 | 72 FZ/TR | HW |
| HCS480.07230 | 480 | 4.4/3.2 | 30+2 | 72 FZ/TR | HW |
| HCS500.07230 | 500 | 4.6/3.2 | 30+2 | 72 FZ/TR | HW |
| HCS520.07230 | 520 | 4.8/3.5 | 30+2 | 72 FZ/TR | HW |
| HCS530.06030 | 530 | 5.0/3.5 | 30+2 | 60 FZ/TR | HW |

| | | | | | |
|--------------|-----|---------|------|-------|----|
| HBS450.05430 | 450 | 4.4/3.2 | 30+2 | 54 WZ | HW |
| HBS450.05430 | 450 | 4.4/3.2 | 30+2 | 72 WZ | HW |
| HBS500.07230 | 500 | 4.6/3.2 | 30+2 | 72 WZ | HW |

| | | | | | |
|--------------|-----|---------|------|----------|----|
| XHC450.07230 | 450 | 4.4/3.2 | 30+2 | 72 FZ/TR | DP |
| XHC460.07230 | 460 | 4.4/3.2 | 30+2 | 72 FZ/TR | DP |
| XHC480.07230 | 480 | 4.4/3.2 | 30+2 | 72 FZ/TR | DP |

Pin holes 2/13/94

| | | | | | |
|--------------|-----|---------|------|----------|----|
| HCS550.06040 | 550 | 5.2/3.5 | 40+2 | 60 FZ/TR | HW |
|--------------|-----|---------|------|----------|----|

Pin holes 2/13/122

SCHELLING: SCORING SAWBLADE

| Item | D | B | d | Z | MAT. |
|-------------|-----|---------|----|-----------|------|
| FI180.03630 | 180 | 4.3/5.5 | 20 | 36 KON/FZ | HW |
| FI200.03620 | 200 | 4.3/5.5 | 20 | 36 KON/FZ | HW |
| FI203.03620 | 200 | 5.0/6.2 | 20 | 36 KON/FZ | HW |

| | | | | | |
|--------------|-----|---------|----|-----------|----|
| XFI180.03620 | 180 | 4.4/5.0 | 20 | 36 KON/FZ | DP |
| XFI200.03620 | 200 | 4.4/5.0 | 20 | 36 KON/FZ | DP |
| XFI201.03620 | 200 | 5.0/5.8 | 20 | 36 KON/FZ | DP |

SCM: MAIN SAWBLADE

| Item | D | B | d | Z | MAT. |
|--------------|-----|---------|--------|----------|------|
| HCS300.06080 | 300 | 4.4/3.2 | 80+PH4 | 60 FZ/TR | HW |
| HCS300.07280 | 300 | 4.4/3.2 | 80+PH4 | 72 FZ/TR | HW |
| HCS350.05680 | 350 | 4.4/3.2 | 80+PH4 | 54 FZ/TR | HW |
| HCS350.07280 | 350 | 4.4/3.2 | 80+PH4 | 72 FZ/TR | HW |
| HCS351.07280 | 350 | 4.6/3.2 | 80+PH4 | 72 FZ/TR | HW |
| HCS355.07280 | 355 | 4.4/3.2 | 80+PH4 | 72 FZ/TR | HW |
| HCS380.07280 | 380 | 4.4/3.2 | 80+PH4 | 72 FZ/TR | HW |
| HCS400.06080 | 400 | 4.4/3.2 | 80+PH4 | 60 FZ/TR | HW |
| HCS400.07280 | 400 | 4.4/3.2 | 80+PH4 | 72 FZ/TR | HW |
| HCS401.07280 | 400 | 4.6/3.2 | 80+PH4 | 72 FZ/TR | HW |

| | | | | | |
|--------------|-----|---------|--------|-------|----|
| HBS350.05680 | 350 | 4.4/3.2 | 80+PH4 | 54 WZ | HW |
| HBS350.07280 | 350 | 4.4/3.2 | 80+PH4 | 72 WZ | HW |
| HBS400.03680 | 400 | 4.4/3.2 | 80+PH4 | 36 WZ | HW |
| HBS400.04880 | 400 | 4.4/3.2 | 80+PH4 | 48 WZ | HW |
| HBS400.06080 | 400 | 4.4/3.2 | 80+PH4 | 60 WZ | HW |
| HBS400.07280 | 400 | 4.4/3.2 | 80+PH4 | 72 WZ | HW |
| HBS401.06080 | 400 | 4.6/3.2 | 80+PH4 | 60 WZ | HW |
| HBS450.03680 | 450 | 4.4/3.2 | 80+PH4 | 36 WZ | HW |
| HBS450.05480 | 450 | 4.4/3.2 | 80+PH4 | 54 WZ | HW |

| | | | | | |
|--------------|-----|---------|--------|----------|----|
| XHC350.07280 | 350 | 4.4/3.2 | 80+PH4 | 72 FZ/TR | DP |
| XHC400.07280 | 400 | 4.4/3.2 | 80+PH4 | 72 FZ/TR | DP |
| XHC450.07280 | 450 | 4.4/3.2 | 80+PH4 | 72 FZ/TR | DP |

Pin holes 2/14/110+2/7/110+4/9/100

SCM: SCORING SAWBLADE

| Item | D | B | d | Z | MAT. |
|-------------|-----|---------|------|-----------|------|
| FI151.03655 | 150 | 4.3/5.5 | 55+3 | 36 KON/FZ | HW |
| FI161.03655 | 160 | 4.3/5.5 | 55+3 | 36 KON/FZ | HW |
| FI162.03655 | 160 | 4.5/5.7 | 55+3 | 36 KON/FZ | HW |

| | | | | | |
|--------------|-----|---------|------|-----------|----|
| XFI160.03645 | 160 | 4.4/5.0 | 55+3 | 36 KON/FZ | DP |
|--------------|-----|---------|------|-----------|----|

Pin holes 3/7/66

SELCO: MAIN SAWBLADE

| Item | D | B | d | Z | MAT. |
|--------------|-----|---------|------|----------|------|
| HCS300.06065 | 300 | 4.4/3.2 | 65+4 | 60 FZ/TR | HW |
| HCS300.07265 | 300 | 4.4/3.2 | 65+4 | 72 FZ/TR | HW |
| HCS320.06065 | 320 | 4.4/3.2 | 65+4 | 60 FZ/TR | HW |
| HCS321.06065 | 320 | 4.6/3.2 | 65+4 | 60 FZ/TR | HW |
| HCS350.07265 | 350 | 4.4/3.2 | 65+4 | 72 FZ/TR | HW |
| HCS361.07265 | 360 | 4.6/3.2 | 65+4 | 72 FZ/TR | HW |

| | | | | | |
|--------------|-----|---------|------|----------|----|
| XHC300.06065 | 300 | 4.4/3.2 | 65+4 | 60 FZ/TR | DP |
| XHC320.06065 | 320 | 4.4/3.2 | 65+4 | 60 FZ/TR | DP |
| XHC350.07265 | 350 | 4.4/3.2 | 65+4 | 72 FZ/TR | DP |
| XHC360.07265 | 360 | 4.4/3.2 | 65+4 | 72 FZ/TR | DP |

Pin holes 2/9/100+2/9/110

| | | | | | |
|--------------|-----|---------|--------|----------|----|
| HCS350.05680 | 350 | 4.4/3.2 | 80+PH4 | 54 FZ/TR | HW |
| HCS350.07280 | 350 | 4.4/3.2 | 80+PH4 | 72 FZ/TR | HW |
| HCS351.07280 | 350 | 4.6/3.2 | 80+PH4 | 72 FZ/TR | HW |
| HCS355.07280 | 355 | 4.4/3.2 | 80+PH4 | 72 FZ/TR | HW |
| HCS400.06080 | 400 | 4.4/3.2 | 80+PH4 | 60 FZ/TR | HW |
| HCS400.07280 | 400 | 4.4/3.2 | 80+PH4 | 72 FZ/TR | HW |
| HCS401.07280 | 400 | 4.6/3.2 | 80+PH4 | 72 FZ/TR | HW |
| HCS430.07280 | 430 | 4.4/3.2 | 80+PH4 | 72 FZ/TR | HW |
| HCS450.07280 | 450 | 4.4/3.2 | 80+PH4 | 72 FZ/TR | HW |
| HCS451.07280 | 450 | 4.6/3.2 | 80+PH4 | 72 FZ/TR | HW |
| HCS452.07280 | 450 | 4.8/3.5 | 80+PH4 | 72 FZ/TR | HW |
| HCS481.07280 | 480 | 4.8/3.5 | 80+6 | 72 FZ/TR | HW |
| HCS482.07280 | 480 | 5.2/3.5 | 80+6 | 72 FZ/TR | HW |

| | | | | | |
|--------------|-----|---------|--------|-------|----|
| HBS350.05480 | 350 | 4.4/3.2 | 80+PH4 | 54 WZ | HW |
| HBS350.07280 | 350 | 4.4/3.2 | 80+PH4 | 72 WZ | HW |
| HBS400.03680 | 400 | 4.4/3.2 | 80+PH4 | 36 WZ | HW |
| HBS400.04880 | 400 | 4.4/3.2 | 80+PH4 | 48 WZ | HW |
| HBS400.06080 | 400 | 4.4/3.2 | 80+PH4 | 60 WZ | HW |
| HBS400.07280 | 400 | 4.4/3.2 | 80+PH4 | 72 WZ | HW |
| HBS401.06080 | 400 | 4.6/3.2 | 80+PH4 | 60 WZ | HW |
| HBS450.03680 | 450 | 4.4/3.2 | 80+PH4 | 36 WZ | HW |
| HBS450.05480 | 450 | 4.4/3.2 | 80+PH4 | 54 WZ | HW |
| HBS451.04880 | 450 | 4.8/3.5 | 80+PH4 | 48 WZ | HW |

| | | | | | |
|--------------|-----|---------|--------|----------|----|
| XHC350.07280 | 350 | 4.4/3.2 | 80+PH4 | 72 FZ/TR | DP |
| XHC400.07280 | 400 | 4.4/3.2 | 80+PH4 | 72 FZ/TR | DP |
| XHC430.07280 | 430 | 4.4/3.2 | 80+PH4 | 72 FZ/TR | DP |
| XHC450.07280 | 450 | 4.4/3.2 | 80+PH4 | 72 FZ/TR | DP |
| XHC451.07280 | 450 | 4.8/3.5 | 80+PH4 | 72 FZ/TR | DP |
| XHC481.07280 | 480 | 4.8/3.5 | 80+6 | 72 FZ/TR | DP |

Pin holes 4/19/120+2/9/130

SELCO: SCORING SAWBLADE

| Item | D | B | d | Z | MAT. |
|-------------|-----|---------|------|-----------|------|
| FI200.03665 | 200 | 4.3/5.5 | 65+4 | 36 KON/FZ | HW |
| FI201.03665 | 200 | 4.7/6.0 | 65+4 | 36 KON/FZ | HW |
| FI202.03665 | 200 | 4.5/5.7 | 65+4 | 36 KON/FZ | HW |
| FI203.03665 | 200 | 5.0/6.2 | 65+4 | 36 KON/FZ | HW |
| FI300.07265 | 300 | 4.3/5.5 | 65+4 | 72 KON/FZ | HW |
| FI301.07265 | 300 | 4.5/5.7 | 65+4 | 72 KON/FZ | HW |
| FI302.07265 | 300 | 4.7/6.0 | 65+4 | 72 KON/FZ | HW |

| | | | | | |
|--------------|-----|---------|------|-----------|----|
| XFI200.03665 | 200 | 4.4/5.0 | 65+4 | 36 KON/FZ | DP |
| XFI200.03645 | 200 | 4.8/5.6 | 65+4 | 36 KON/FZ | DP |

Pin holes 2/9/100+2/9/110

HW CONICAL SCORING SAWBLADES

ART. FI

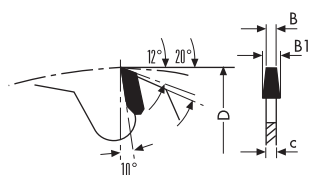

- **KON/FZ** conical teeth
- For cutting double sided **veneer and laminate boards, MDF and particle board**
- To be used on panel sizing machines that allow the vertical adjustment of the scorer in relation to the panel sizing sawblade
- **HW grade: KCR05 (K01-C4)**

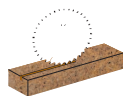
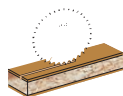
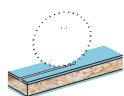

| Item | D | d | B-B1/c | Z | Pin holes |
|--------------------------------|-----|----|-------------|----|-----------|
| FI080.01220 | 80 | 20 | 3,1-4,0/2,2 | 12 | |
| FI100.02020 | 100 | 20 | 3,1-4,3/2,2 | 20 | |
| FI100.02022 | 100 | 22 | 3,1-4,3/2,2 | 20 | |
| FI110.02020 | 110 | 20 | 3,1-4,3/2,2 | 20 | |
| FI110.02022 | 110 | 22 | 3,1-4,3/2,2 | 20 | |
| FI120.02420 | 120 | 20 | 3,1-4,3/2,2 | 20 | |
| FI120.02422 | 120 | 22 | 3,1-4,3/2,2 | 20 | |
| FI121.02445 <i>selling out</i> | 120 | 45 | 4,3-5,5/2,8 | 24 | |
| FI122.02020 | 120 | 20 | 3,4-4,5/2,2 | 20 | |
| FI125.02420 | 125 | 20 | 3,1-4,3/2,2 | 24 | |
| FI125.02445 | 125 | 45 | 3,1-4,3/2,2 | 24 | |
| FI126.02420 | 125 | 20 | 4,3-5,5/3,2 | 24 | |
| FI126.02422 | 125 | 22 | 4,3-5,5/3,2 | 24 | |
| FI126.02445 | 125 | 45 | 4,3-5,5/3,2 | 24 | |
| FI127.02420 | 125 | 20 | 3,4-4,5/2,2 | 24 | |
| FI127.02430 | 125 | 30 | 3,4-4,5/2,2 | 24 | |
| FI150.03630 | 150 | 30 | 3,4-4,5/2,2 | 36 | |
| FI150.03645 <i>selling out</i> | 150 | 45 | 3,4-4,5/2,2 | 36 | |
| FI150.03650 <i>selling out</i> | 150 | 50 | 3,4-4,5/2,2 | 36 | |
| FI151.02430 | 150 | 30 | 4,3-5,5/3,2 | 24 | |
| FI151.02445 | 150 | 45 | 4,3-5,5/3,2 | 24 | |
| FI151.03630 | 150 | 30 | 4,3-5,5/3,2 | 36 | |
| FI151.03645 | 150 | 45 | 4,3-5,5/3,2 | 36 | Giben |
| FI151.03655 | 150 | 55 | 4,3-5,5/3,2 | 36 | Gabbiani |
| FI152.03630 | 150 | 30 | 3,9-5,1/2,8 | 36 | |
| FI153.03630 | 150 | 30 | 3,1-4,3/2,2 | 36 | |

| Item | D | d | B-B1/c | Z | Pin holes |
|-------------|-----|----|-------------|----|----------------------|
| FI161.02430 | 160 | 30 | 4,3-5,5/3,2 | 36 | |
| FI161.03620 | 160 | 20 | 4,3-5,5/3,2 | 36 | |
| FI161.03645 | 160 | 45 | 4,3-5,5/3,2 | 36 | Giben |
| FI161.03655 | 160 | 55 | 4,3-5,5/3,2 | 36 | MacMazza Gabbiani |
| FI162.03645 | 160 | 45 | 4,5-5,7/3,2 | 36 | Giben |
| FI162.03655 | 160 | 55 | 4,5-5,7/3,2 | 36 | Gabbiani |
| FI163.03655 | 160 | 55 | 4,7-6,0/3,5 | 36 | Gabbiani |
| FI180.03620 | 180 | 20 | 4,3-5,5/3,2 | 36 | |
| FI180.03630 | 180 | 30 | 4,3-5,5/3,2 | 36 | 2/10/60 |
| FI180.03650 | 180 | 50 | 4,3-5,5/3,2 | 44 | Giben |
| FI180.03645 | 180 | 45 | 4,3-5,5/3,2 | 36 | Holzma |
| FI180.03655 | 180 | 55 | 4,3-5,5/3,2 | 36 | Giben |
| FI181.03645 | 180 | 45 | 4,7-6,0/3,5 | 36 | Holzma |
| FI182.03655 | 180 | 55 | 5,0-6,2/3,5 | 36 | Giben |
| FI183.03620 | 180 | 20 | 5,8-7,0/4,0 | 36 | Anthon |
| FI200.03620 | 200 | 20 | 4,3-5,5/3,2 | 36 | |
| FI200.03630 | 200 | 30 | 4,3-5,5/3,2 | 36 | |
| FI200.03645 | 200 | 45 | 4,3-5,5/3,2 | 36 | Holzma |
| FI200.03665 | 200 | 65 | 4,3-5,5/3,2 | 36 | Selco |
| FI200.03680 | 200 | 80 | 4,3-5,5/3,2 | 36 | Gabbiani |
| FI201.03645 | 200 | 45 | 4,7-6,0/3,5 | 36 | Holzma |
| FI201.03665 | 200 | 65 | 4,7-6,0/3,5 | 36 | Selco |
| FI202.03665 | 200 | 65 | 4,5-5,7/3,2 | 36 | Selco |
| FI203.03665 | 200 | 65 | 5,0-6,2/3,5 | 36 | Selco |
| FI204.03645 | 200 | 45 | 5,8-7,0/4,0 | 36 | Holzma |
| FI215.04250 | 215 | 50 | 4,3-5,5/3,2 | 42 | Giben |
| FI216.04250 | 215 | 50 | 4,5-5,7/3,2 | 42 | Giben |
| FI280.04855 | 280 | 55 | 4,5-5,6/3,2 | 48 | MacMazza |
| FI300.04850 | 300 | 50 | 4,3-5,5/3,2 | 48 | Giben |
| FI300.07265 | 300 | 65 | 4,3-5,5/3,2 | 72 | Selco |
| FI301.04850 | 300 | 50 | 4,5-5,7/3,2 | 48 | Giben |
| FI301.07265 | 300 | 65 | 4,5-5,7/3,2 | 72 | Selco |
| FI302.07265 | 300 | 65 | 4,7-6,0/3,5 | 72 | Selco |

HW ADJUSTABLE SCORING SAWBLADES

ART. FL

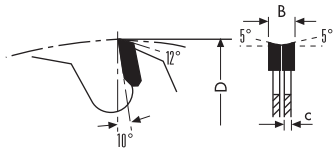

- LFZ flat teeth
- Supplied with spacers
- For cutting double sided veneer and laminate boards, MDF and particle board
- For panel sizing machines
- HW grade: KCR05 (K01-C4)

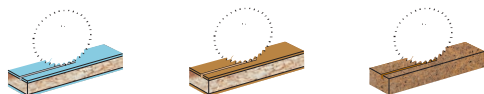

| Item | D | d | B/c | Z |
|-------------|-----|----|-------------|-------------|
| FL080.01020 | 80 | 20 | 2,8-3,6/2,2 | 10+10 |
| FL100.01220 | 100 | 20 | 2,8-3,6/2,2 | 10+10 |
| FL100.01222 | 100 | 22 | 2,8-3,6/2,2 | 10+10 |
| FL101.01220 | 100 | 20 | 3,1-3,9/2,2 | 10+10 |
| FL101.01222 | 100 | 22 | 3,1-3,9/2,2 | 10+10 |
| FL120.01220 | 120 | 20 | 2,8-3,6/2,2 | 12+12 |
| FL120.01222 | 120 | 22 | 2,8-3,6/2,2 | 12+12 |
| FL121.01220 | 120 | 20 | 3,1-3,9/2,2 | 12+12 |
| FL121.01222 | 120 | 22 | 3,1-3,9/2,2 | 12+12 |
| FL125.01220 | 125 | 20 | 2,8-3,6/2,2 | 12+12 |
| FL125.01222 | 125 | 22 | 2,8-3,6/2,2 | 12+12 |
| FL126.01220 | 125 | 20 | 3,1-3,9/2,2 | 12+12 |
| FL126.01222 | 125 | 22 | 3,1-3,9/2,2 | 12+12 |
| FL126.01230 | 125 | 30 | 3,1-3,9/2,2 | 12+12 |
| FL127.02045 | 125 | 45 | 4,0-4,8/2,2 | 20+20 Giben |

HW adjustable scoring sawblades unit without rings

| | | | | |
|---------------|-----|------|-------------|-------|
| FL120.01250AN | 120 | 50+4 | 2,8-3,8/2,2 | 12+12 |
|---------------|-----|------|-------------|-------|

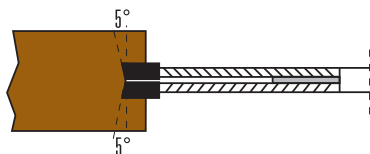

HW PANEL SIZING SAWBLADES

ART. HBS

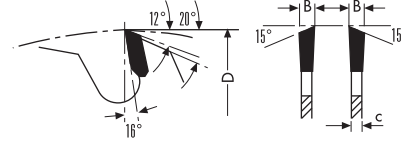

- WZ alternate top bevel teeth
- For cutting double sided veneer and laminate boards, MDF and particle board
- = no-noise with a special sound absorbing resin inside the silent slots
- HW grade: KCR05 (K01-C4)

Pin holes:

PH01= 2/10/60

PH02= 2/7/42 + 2/9,5/46,5 + 2/10/60

PH04= 2/14/110 + 2/7/110 + 4/9/100 + 4/19/120 + 2/9/130 (Selco-Gabbani-SCM)

PH05= 4/15/105 + 3/7/100 (Giben-Homag-MacMazza)



| Item | D | d | B/c | Z | Pin holes |
|--------------|-----|----|---------|----|-----------------|
| HBS300.04830 | 300 | 30 | 4,4/3,2 | 48 | PH02 |
| HBS300.06030 | 300 | 30 | 4,4/3,2 | 60 | PH02 |
| HBS300.07230 | 300 | 30 | 4,4/3,2 | 72 | PH02 |
| HBS320.03650 | 320 | 50 | 4,4/3,2 | 36 | Giben |
| HBS350.05630 | 350 | 30 | 4,4/3,2 | 54 | PH02 |
| HBS350.05675 | 350 | 75 | 4,4/3,2 | 54 | PH05 |
| HBS350.05680 | 350 | 80 | 4,4/3,2 | 54 | PH04 |
| HBS350.07230 | 350 | 30 | 4,4/3,2 | 72 | PH02 |
| HBS350.07275 | 350 | 75 | 4,4/3,2 | 72 | PH05 |
| HBS350.07280 | 350 | 80 | 4,4/3,2 | 72 | PH04 |
| HBS400.03630 | 400 | 30 | 4,4/3,2 | 36 | PH01 |
| HBS400.03680 | 400 | 80 | 4,4/3,2 | 36 | PH04 |
| HBS400.06030 | 400 | 30 | 4,4/3,2 | 60 | PH01 |
| HBS400.06075 | 400 | 75 | 4,4/3,2 | 60 | Giben-Homag |
| HBS400.06080 | 400 | 80 | 4,4/3,2 | 60 | PH04 |
| HBS400.07230 | 400 | 30 | 4,4/3,2 | 72 | PH01 |
| HBS400.07275 | 400 | 75 | 4,4/3,2 | 72 | Giben-Homag |
| HBS400.07280 | 400 | 80 | 4,4/3,2 | 72 | PH04 |
| HBS401.06075 | 400 | 75 | 4,6/3,2 | 60 | Giben-Homag |
| HBS401.06080 | 400 | 80 | 4,6/3,2 | 60 | PH04 |
| HBS450.03680 | 450 | 80 | 4,4/3,2 | 36 | PH04 |
| HBS450.05430 | 450 | 30 | 4,4/3,2 | 54 | PH01 +Schelling |
| HBS450.05480 | 450 | 80 | 4,4/3,2 | 54 | PH04 |
| HBS450.07230 | 450 | 30 | 4,4/3,2 | 72 | PH01 +Schelling |
| HBS451.04880 | 450 | 80 | 4,8/3,5 | 48 | PH04 |
| HBS500.07230 | 500 | 30 | 4,6/3,2 | 72 | PH01 +Schelling |

HW PANEL SIZING SAWBLADES

ART. HCS

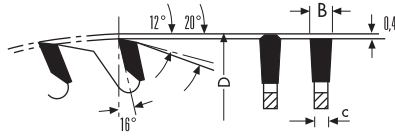

- FZ/TR triple chip teeth
- For cutting double sided veneer and laminate boards, MDF, particle board and plastic materials
- = no-noise with a special sound absorbing resin inside the silent slots
- HW grade: KCR05 (K01-C4)

Pin holes:

- PH01= 2/10/60 - PH02= 2/7/42 + 2/9,5/46,5 + 2/10/60
- PH04= 2/14/110 + 2/7/110 + 4/9/100 + 4/19/120 + 2/9/130 (Selco-Gabbani-SCM)
- PH05= 4/15/105 + 3/7/100 (Giben-Homag-MacMazza)



| Item | D | d | B/c | Z | Pin holes |
|--------------|-----|----|---------|----|-----------|
| HCS300.06030 | 300 | 30 | 4,4/3,2 | 60 | PH02 |
| HCS300.06065 | 300 | 65 | 4,4/3,2 | 60 | Selco |
| HCS300.06075 | 300 | 75 | 4,4/3,2 | 60 | Homag |
| HCS300.06080 | 300 | 80 | 4,4/3,2 | 60 | Gabbiani |
| HCS300.07230 | 300 | 30 | 4,4/3,2 | 72 | PH02 |
| HCS300.07265 | 300 | 65 | 4,4/3,2 | 72 | Selco |
| HCS300.07280 | 300 | 80 | 4,4/3,2 | 72 | Gabbiani |
| | | | | | |
| HCS320.06050 | 320 | 50 | 4,4/3,2 | 60 | Giben |
| HCS320.06065 | 320 | 65 | 4,4/3,2 | 60 | Selco |
| HCS320.07250 | 320 | 50 | 4,4/3,2 | 72 | Giben |
| HCS320.07275 | 320 | 75 | 4,4/3,2 | 72 | Giben |
| | | | | | |
| HCS321.06065 | 320 | 65 | 4,6/3,2 | 60 | Selco |
| | | | | | |
| HCS330.06050 | 330 | 50 | 4,4/3,2 | 60 | Giben |
| | | | | | |
| HCS350.05630 | 350 | 30 | 4,4/3,2 | 54 | PH02 |
| HCS350.05675 | 350 | 75 | 4,4/3,2 | 54 | PH05 |
| HCS350.05680 | 350 | 80 | 4,4/3,2 | 54 | PH04 |
| HCS350.07230 | 350 | 30 | 4,4/3,2 | 72 | PH02 |
| HCS350.07250 | 350 | 50 | 4,4/3,2 | 72 | Giben |
| HCS350.07260 | 350 | 60 | 4,4/3,2 | 72 | Holzma |
| HCS350.07265 | 350 | 65 | 4,4/3,2 | 72 | Selco |
| HCS350.07275 | 350 | 75 | 4,4/3,2 | 72 | PH05 |
| HCS350.07280 | 350 | 80 | 4,4/3,2 | 72 | PH04 |
| | | | | | |
| HCS351.07280 | 350 | 80 | 4,6/3,2 | 72 | PH04 |
| | | | | | |
| HCS355.07230 | 355 | 30 | 4,4/3,2 | 72 | PH02 |
| HCS355.07275 | 355 | 75 | 4,4/3,2 | 72 | PH05 |
| HCS355.07280 | 355 | 80 | 4,4/3,2 | 72 | PH04 |
| | | | | | |
| HCS360.07250 | 360 | 50 | 4,4/3,2 | 72 | Giben |
| | | | | | |
| HCS361.07265 | 360 | 65 | 4,6/3,2 | 72 | Selco |
| | | | | | |
| HCS370.07230 | 370 | 30 | 4,4/3,2 | 72 | Schelling |
| | | | | | |
| HCS380.07250 | 380 | 50 | 4,4/3,2 | 72 | Giben |
| HCS380.07260 | 380 | 60 | 4,4/3,2 | 72 | Holzma |
| HCS380.07275 | 380 | 75 | 4,4/3,2 | 72 | PH05 |
| HCS380.07280 | 380 | 80 | 4,4/3,2 | 72 | PH04 |
| | | | | | |
| HCS381.07260 | 380 | 60 | 4,8/3,5 | 72 | Holzma |
| HCS381.08460 | 380 | 60 | 4,8/3,5 | 84 | Holzma |

| Item | D | d | B/c | Z | Pin holes |
|--------------|-----|-----|---------|----|---------------|
| HCS400.06030 | 400 | 30 | 4,4/3,2 | 60 | PH01 |
| HCS400.06075 | 400 | 75 | 4,4/3,2 | 60 | Giben-Homag |
| HCS400.06080 | 400 | 80 | 4,4/3,2 | 60 | PH04 |
| HCS400.07230 | 400 | 30 | 4,4/3,2 | 72 | PH01 |
| HCS400.07260 | 400 | 60 | 4,4/3,2 | 72 | Anthon |
| HCS400.07275 | 400 | 75 | 4,4/3,2 | 72 | Giben-Homag |
| HCS400.07280 | 400 | 80 | 4,4/3,2 | 72 | PH04 |
| | | | | | |
| HCS401.07280 | 400 | 80 | 4,6/3,2 | 72 | PH04 |
| | | | | | |
| HCS402.07260 | 400 | 60 | 4,8/3,5 | 72 | Holzma |
| | | | | | |
| HCS420.07280 | 420 | 80 | 4,4/3,2 | 72 | PH04 |
| | | | | | |
| HCS421.07260 | 420 | 60 | 4,8/3,5 | 72 | Holzma |
| | | | | | |
| HCS430.07230 | 430 | 30 | 4,4/3,2 | 72 | PH01 |
| HCS430.07260 | 430 | 60 | 4,4/3,2 | 72 | Anthon |
| HCS430.07275 | 430 | 75 | 4,4/3,2 | 72 | Giben |
| HCS430.07280 | 430 | 80 | 4,4/3,2 | 72 | PH04 |
| HCS430.09675 | 430 | 75 | 4,4/3,2 | 96 | Giben |
| | | | | | |
| HCS431.07280 | 430 | 80 | 4,6/3,2 | 72 | PH04 |
| | | | | | |
| HCS450.07230 | 450 | 30 | 4,4/3,2 | 72 | Schelling |
| HCS450.07260 | 450 | 60 | 4,4/3,2 | 72 | Anthon-Holzma |
| HCS450.07275 | 450 | 75 | 4,4/3,2 | 72 | MacMazza |
| HCS450.07280 | 450 | 80 | 4,4/3,2 | 72 | PH04 |
| | | | | | |
| HCS451.07280 | 450 | 80 | 4,6/3,2 | 72 | PH04 |
| | | | | | |
| HCS452.07260 | 450 | 60 | 4,8/3,5 | 72 | Holzma |
| HCS452.07280 | 450 | 80 | 4,8/3,5 | 72 | PH04 |
| | | | | | |
| HCS460.07230 | 460 | 30 | 4,4/3,2 | 72 | Schelling |
| | | | | | |
| HCS470.07275 | 470 | 75 | 4,4/3,2 | 72 | Giben |
| HCS470.09675 | 470 | 75 | 4,4/3,2 | 96 | Giben |
| | | | | | |
| HCS480.07230 | 480 | 30 | 4,4/3,2 | 72 | Schelling |
| | | | | | |
| HCS481.07260 | 480 | 60 | 4,8/3,5 | 72 | Holzma |
| HCS481.07280 | 480 | 80 | 4,8/3,5 | 72 | Selco |
| | | | | | |
| HCS482.07280 | 480 | 80 | 5,2/3,5 | 72 | Selco |
| | | | | | |
| HCS500.06060 | 500 | 60 | 4,8/3,5 | 60 | Holzma |
| HCS500.07230 | 500 | 30 | 4,6/3,2 | 72 | Schelling |
| HCS500.07260 | 500 | 60 | 4,8/3,5 | 72 | Holzma |
| | | | | | |
| HCS520.06060 | 520 | 60 | 4,8/3,5 | 60 | Holzma |
| HCS520.07230 | 520 | 30 | 4,8/3,5 | 72 | Schelling |
| | | | | | |
| HCS530.06030 | 530 | 30 | 5,0/3,5 | 60 | Schelling |
| HCS531.06060 | 530 | 60 | 5,8/4,0 | 60 | Anthon |
| | | | | | |
| HCS540.08460 | 540 | 60 | 4,8/3,5 | 84 | Holzma |
| | | | | | |
| HCS541.06060 | 540 | 60 | 5,8/4,0 | 60 | Holzma |
| | | | | | |
| HCS550.06040 | 550 | 40 | 5,2/3,5 | 60 | Schelling |
| HCS550.07299 | 550 | 100 | 5,2/3,5 | 72 | Giben |
| | | | | | |
| HCS565.07299 | 565 | 100 | 5,2/3,5 | 72 | Giben |
| | | | | | |
| HCS570.06060 | 570 | 60 | 4,8/3,5 | 60 | Holzma |
| | | | | | |
| HCS571.09660 | 570 | 60 | 5,8/4,0 | 96 | Holzma |
| | | | | | |
| HCS600.06060 | 600 | 60 | 5,8/4,0 | 60 | Holzma |
| HCS600.07260 | 600 | 60 | 5,8/4,0 | 72 | Holzma |

HW SCORING SAWBLADES FOR EDGE BANDING AND SQUARING MACHINES

ART. FM

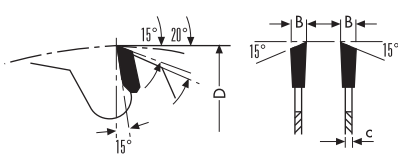

- **WZ** alternate top bevel teeth
- For cutting double sided **veneer and laminate boards, MDF and particle board**
- **HW grade: KCR06 (K01-C4)**

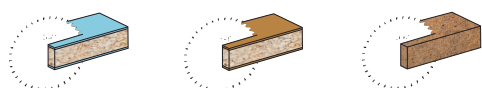

| Item | D | d | B/c | Z |
|-------------|-----|----|---------|----|
| FM100.02020 | 100 | 20 | 3,2/2,2 | 20 |
| FM115.02430 | 115 | 30 | 2,6/1,8 | 24 |
| FM120.03020 | 120 | 20 | 3,2/2,2 | 30 |
| FM125.02020 | 125 | 20 | 3,2/2,2 | 20 |
| FM160.04830 | 160 | 30 | 3,2/2,2 | 48 |

HW SCORING SAWBLADES FOR EDGE BANDING AND SQUARING MACHINES (for Art. FP)

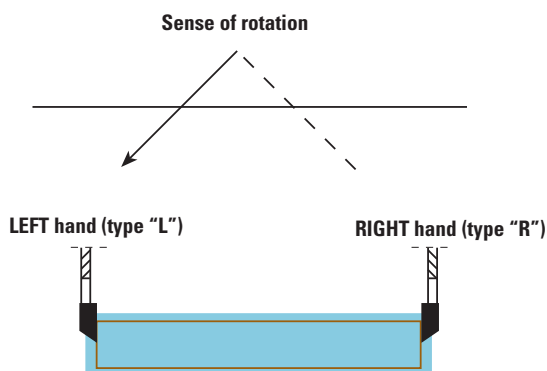

HW SCORING SAWBLADES FOR EDGE BANDING AND SQUARING MACHINES

ART. FP

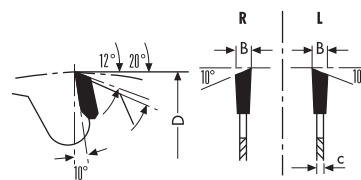

- **ES** 1 sided top bevel teeth
- **R**= right hand
- **L**= left hand
- For cutting double sided **veneer and laminate boards, thermoplastic boards, MDF and chipboard**
- **HW grade: KCR06 (K01-C4)**



| Item | D | d | B/c | Z |
|--------------|-----|------------|---------|----|
| FP100.02020R | 100 | 20 | 3,2/2,2 | 20 |
| FP100.02020L | 100 | 20 | 3,2/2,2 | 20 |
| FP115.02430R | 115 | 30 Stefani | 2,6/1,8 | 24 |
| FP115.02430L | 115 | 30 Stefani | 2,6/1,8 | 24 |
| FP120.03020R | 120 | 20 | 3,2/2,2 | 30 |
| FP120.03020L | 120 | 20 | 3,2/2,2 | 30 |
| FP125.03020R | 125 | 20 | 3,2/2,2 | 30 |
| FP125.03020L | 125 | 20 | 3,2/2,2 | 30 |
| FP150.03620R | 150 | 20 | 3,2/2,2 | 36 |
| FP150.03620L | 150 | 20 | 3,2/2,2 | 36 |
| FP150.03630R | 150 | 30 | 3,2/2,2 | 36 |
| FP150.03630L | 150 | 30 | 3,2/2,2 | 36 |
| FP150.03655R | 150 | 55 | 3,2/2,2 | 36 |
| FP150.03655L | 150 | 55 | 3,2/2,2 | 36 |
| FP150.04820R | 150 | 20 | 3,2/2,2 | 48 |
| FP150.04820L | 150 | 20 | 3,2/2,2 | 48 |
| FP150.04830R | 150 | 30 | 3,2/2,2 | 48 |
| FP150.04830L | 150 | 30 | 3,2/2,2 | 48 |
| FP150.04855R | 150 | 55 | 3,2/2,2 | 48 |
| FP150.04855L | 150 | 55 | 3,2/2,2 | 48 |
| FP180.03630R | 180 | 30 | 3,2/2,2 | 36 |
| FP180.03630L | 180 | 30 | 3,2/2,2 | 36 |
| FP180.03655R | 180 | 55 | 3,2/2,2 | 36 |
| FP180.03655L | 180 | 55 | 3,2/2,2 | 36 |
| FP180.03660R | 180 | 60 | 3,2/2,2 | 36 |
| FP180.03660L | 180 | 60 | 3,2/2,2 | 36 |
| FP200.04830R | 200 | 30 | 3,2/2,2 | 48 |
| FP200.04830L | 200 | 30 | 3,2/2,2 | 48 |
| FP200.04840R | 200 | 40 | 3,2/2,2 | 48 |
| FP200.04840L | 200 | 40 | 3,2/2,2 | 48 |
| FP200.04880R | 200 | 80 | 3,2/2,2 | 48 |
| FP200.04880L | 200 | 80 | 3,2/2,2 | 48 |

LIST OF MACHINES (SAWBLADES FOR BUILDING)

| Diameter | Brand | Model-no. | |
|-----------|-------------------------|--|-------------------------------|
| 250 x 30 | De Walt | DW250, DW320, 1251, 1501, 1503 | |
| | | DW710, DW125, DW150, DW720, DW742 | |
| | Elu | TGS 171, TGS 172, 170, 171, 172, 173, | |
| | | TKS171 | |
| | Haffner | TGS 162, Sp 198, GS 166, AKS, GS 150 | |
| | | Sp 195, Sp189, Sp 197, TGS198, GS1 | |
| | | 2W, 2D | |
| | Metabo | TK 1685 Magnum, TK 1685D, TK 1685, | |
| | | TK 1688, TK 1688D, TKU 1633, TKU 1693 | |
| | Ulmia | 1610, 1622, 1625, 1711 | |
| | Scheppach | TKS 250 | |
| | Elektra-Beckum | PK 3100 WM 250, PK 4200 DN 4200 | |
| | | PK 6000 DN 250, KS 250, KGS 250, GKS 300 | |
| | Festo | AD85-1, AE85 | |
| | Flottjet | 1011, 2011, 3011 | |
| Mafell | MKS85, MS85, Erika 85 | | |
| Stayer | SLL250, SCE250, CP66 | | |
| 300 x 30 | De Walt | DW 1370, 142 DS, 160 DS, 1635, | |
| | | 4L/1875/2155 3, 3L | |
| | Haffner | Sp223, TGS 168, GS 157, | |
| | | GS 158, TGS 169, Sp 224 | |
| | Ulmia | 1711, 1712, 1725 | |
| | Metabo | TK 1685 Magnum | |
| | Schleicher | 330, 310 | |
| | Holz-Her | PKS 1212, -1211, -1215, -1220, | |
| | | PKS 275 -1210, -1213 | |
| | 315 x 30 | Haffner | KS 120 |
| | | Hanning | HTK 315, 3 VS |
| | | Mafell | Biberex, Biber |
| | | Matabo | TK 1685 Magnum |
| | | Scheppach | TKH, TKU, TK |
| | | Elektra-Beckum | Combi HS 315 |
| Lutz | | KKS 400, JUMBO 2000, RBK 500 | |
| Alko | | Holzmeister S, Holzmeister H | |
| Atika | | ATK 315 H | |
| Lescha | | TKS 315 N, TKS 315 H, TKS 315 HS | |
| 350 x 30 | De Walt | C14 | |
| | Ulmia | 1711, 1712, 1725 | |
| 400 x 30 | De Walt | C 14, 163546+62, 2155-4+6 | |
| | Haffner | KS 155/DGS 184, DGS 184 E | |
| | Mafell | VKS 130, VKS 160, AZB, | |
| | | TD3, TDH4, TK 150, BK3 | |
| | Holz-Her | B7K, 277 | |
| | Avola | ZB 400, ABH 400 | |
| | Atika | ABK 400, ABH 400 | |
| | Lutz | LBK 500 | |
| | Elektra | BS 3100 WNB/400, BS 4200 DNB/400 | |
| | | BS 6000 DNB/500 | |
| | 450 x 30 | Mafell | BKV4, TDH5, TDH 450, BK |
| | | Avola | ZBV 450, ZB 450 |
| | | Atika | ABH 450, BWK 450, ATU |
| | | Elektra-Beckum | BS 3100 WNB/400, |
| | | | BS4200 DNB/400, BS600 DNB/500 |
| Lutz | RKS 700 | | |
| Alko | W 450/W500 | | |
| Scheppach | BS 500, BSH 500, WS 500 | | |

HW SAWBLADES FOR BUILDING SITES

ART. GA

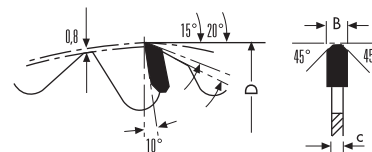

- FZ/FA flat, beveled teeth with anti-kickback design
- For cutting slab woods and boards, timber with parts of concrete and metal (nails, metal fittings), porous concrete blocks
- For table saws
- HW grade: HC10 (K10-C3)

Pin holes: PH01= 2/10/60



| Item | D | d | B/c | Z | Pin holes |
|-------------|-----|----|---------|-------------------|-----------|
| GA300.02030 | 300 | 30 | 3,2/2,2 | 20 +anti-kickback | PH01 |
| GA315.02030 | 315 | 30 | 3,2/2,2 | 20 +anti-kickback | PH01 |
| GA350.02430 | 350 | 30 | 3,2/2,2 | 24 +anti-kickback | PH01 |

visit our website

www.sistemiklein.com



HW SAWBLADES FOR ALUMINIUM

ART. LA

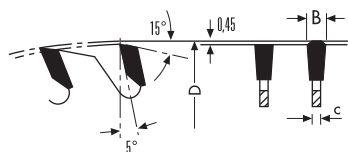

- FZ/TR triple chip teeth
- 5° positive hook angle
- For Alu, PVC and non-ferrous metals. For cutting aluminium profiles and extrusions with thickness of 2-5mm
- For table saws
- = no-noise with a special sound absorbing resin inside the silent slots
- HW grade: HC10 (K10-C3)

* Thin kerf saw blades.
Suitable for working on machine without casing.

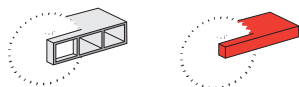

| Item | D | d | B/c | Z | Pin holes |
|--------------------|-----|----|---------|-----|-----------|
| LA200.06430 | 200 | 30 | 3,2/2,5 | 64 | 2/11/63 |
| LA200.06432 | 200 | 32 | 3,2/2,5 | 64 | 2/11/63 |
| LA250.06030 | 250 | 30 | 3,4/2,6 | 60 | 2/11/63 |
| LA250.06032 | 250 | 32 | 3,4/2,6 | 60 | 2/11/63 |
| LA250.08030 | 250 | 30 | 3,4/2,6 | 80 | 2/11/63 |
| LA250.08032 | 250 | 32 | 3,4/2,6 | 80 | 2/11/63 |
| LA300.07230 | 300 | 30 | 3,4/2,6 | 72 | 2/11/63 |
| LA300.07232 | 300 | 32 | 3,4/2,6 | 72 | 2/11/63 |
| LA300.08430 | 300 | 30 | 3,4/2,6 | 84 | 2/11/63 |
| LA300.08432 | 300 | 32 | 3,4/2,6 | 84 | 2/11/63 |
| LA300.09630 | 300 | 30 | 3,4/2,6 | 96 | 2/11/63 |
| LA300.09632 | 300 | 32 | 3,4/2,6 | 96 | 2/11/63 |
| LA350.08430 | 350 | 30 | 3,4/2,6 | 84 | 2/11/63 |
| LA350.08432 | 350 | 32 | 3,4/2,6 | 84 | 2/11/63 |
| LA350.09630 | 350 | 30 | 3,4/2,6 | 96 | 2/11/63 |
| LA350.09632 | 350 | 32 | 3,4/2,6 | 96 | 2/11/63 |
| LA350.10830 | 350 | 30 | 3,4/2,6 | 108 | 2/11/63 |
| LA350.10832 | 350 | 32 | 3,4/2,6 | 108 | 2/11/63 |
| LA400.09630 | 400 | 30 | 4,0/3,2 | 96 | 2/11/63 |
| LA400.09632 | 400 | 32 | 4,0/3,2 | 96 | 2/11/63 |
| LA400.12030 | 400 | 30 | 4,0/3,2 | 120 | 2/11/63 |
| LA400.12032 | 400 | 32 | 4,0/3,2 | 120 | 2/11/63 |
| LA400.19632 * NEW | 400 | 32 | 3,6/3,0 | 96 | 2/11/63 |
| LA420.09630 NEW | 420 | 30 | 4,0/3,2 | 96 | 2/11/63 |
| LA420.09632 | 420 | 32 | 4,0/3,2 | 96 | 2/11/63 |
| LA450.09630 | 450 | 30 | 4,0/3,2 | 96 | 2/11/63 |
| LA450.09632 | 450 | 32 | 4,0/3,2 | 96 | 2/11/63 |
| LA450.10830 | 450 | 30 | 4,0/3,2 | 108 | 2/11/63 |
| LA450.10832 | 450 | 32 | 4,0/3,2 | 108 | 2/11/63 |
| LA450.19632 * NEW | 450 | 32 | 3,8/3,2 | 96 | 2/11/63 |
| LA500.12030 | 500 | 30 | 4,6/3,6 | 120 | 2/11/63 |
| LA500.12032 | 500 | 32 | 4,6/3,6 | 120 | 2/11/63 |
| LA500.12130 NEW | 500 | 30 | 4,0/3,2 | 120 | 2/11/63 |
| LA500.12132 * | 500 | 32 | 4,0/3,2 | 120 | 2/11/63 |
| LA550.14030 | 550 | 30 | 4,6/3,6 | 140 | 2/11/63 |
| LA600.14030 | 600 | 30 | 4,6/3,6 | 140 | 2/11/63 |

HW SAWBLADES FOR ALUMINIUM

ART. LB

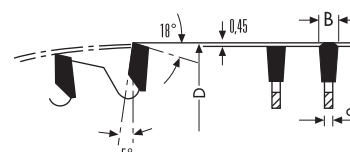

- FZ/TR triple chip teeth
- 5° negative hook angle
- For Alu, PVC and non-ferrous metals
- For table saws
- = no-noise with a special sound absorbing resin inside the silent slots
- HW grade: HC10 (K10-C3)

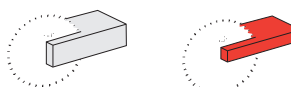

| Item | D | d | B/c | Z | Pin holes |
|-------------|-----|----|---------|-----|-----------|
| LB200.06430 | 200 | 30 | 3,2/2,5 | 64 | 2/11/63 |
| LB200.06432 | 200 | 32 | 3,2/2,5 | 64 | 2/11/63 |
| LB250.06030 | 250 | 30 | 3,4/2,6 | 60 | 2/11/63 |
| LB250.08030 | 250 | 30 | 3,4/2,6 | 80 | 2/11/63 |
| LB250.08032 | 250 | 32 | 3,4/2,6 | 80 | 2/11/63 |
| LB300.07230 | 300 | 30 | 3,4/2,6 | 72 | 2/11/63 |
| LB300.08430 | 300 | 30 | 3,4/2,6 | 84 | 2/11/63 |
| LB300.08432 | 300 | 32 | 3,4/2,6 | 84 | 2/11/63 |
| LB300.09630 | 300 | 30 | 3,4/2,6 | 96 | 2/11/63 |
| LB300.09632 | 300 | 32 | 3,4/2,6 | 96 | 2/11/63 |
| LB350.08430 | 350 | 30 | 3,4/2,6 | 84 | 2/11/63 |
| LB350.08432 | 350 | 32 | 3,4/2,6 | 84 | 2/11/63 |
| LB350.09630 | 350 | 30 | 3,4/2,6 | 96 | 2/11/63 |
| LB350.09632 | 350 | 32 | 3,4/2,6 | 96 | 2/11/63 |
| LB350.10830 | 350 | 30 | 3,4/2,6 | 108 | 2/11/63 |
| LB350.10832 | 350 | 32 | 3,4/2,6 | 108 | 2/11/63 |
| LB400.09630 | 400 | 30 | 4,0/3,2 | 96 | 2/11/63 |
| LB400.09632 | 400 | 32 | 4,0/3,2 | 96 | 2/11/63 |
| LB400.12030 | 400 | 30 | 4,0/3,2 | 120 | 2/11/63 |
| LB400.12032 | 400 | 32 | 4,0/3,2 | 120 | 2/11/63 |
| LB450.09630 | 450 | 30 | 4,0/3,2 | 96 | 2/11/63 |
| LB450.09632 | 450 | 32 | 4,0/3,2 | 96 | 2/11/63 |
| LB450.10830 | 450 | 30 | 4,0/3,2 | 108 | 2/11/63 |
| LB450.10832 | 450 | 32 | 4,0/3,2 | 108 | 2/11/63 |
| LB500.12030 | 500 | 30 | 4,6/3,6 | 120 | 2/11/63 |
| LB500.12032 | 500 | 32 | 4,6/3,6 | 120 | 2/11/63 |
| LB550.14030 | 550 | 30 | 4,6/3,6 | 140 | 2/11/63 |
| LB600.14030 | 600 | 30 | 4,6/3,6 | 140 | 2/11/63 |

RPM suggested referred to the blade diameter

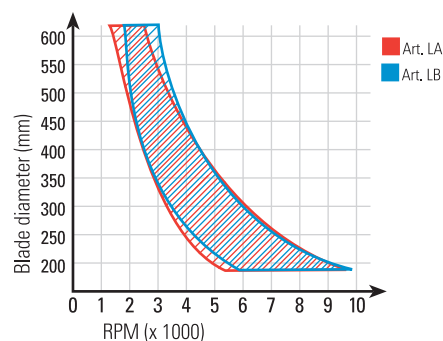

Other sizes are available on request

HW SAWBLADES FOR PVC

ART. LE

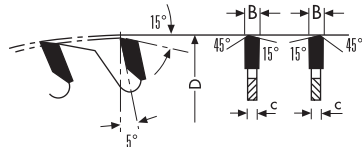

- WZ/FA alternate-trap, teeth
- Suitable for cutting **PVC**
- 🎵 = **no-noise with a special sound absorbing resin inside the silent slots**
- For table saws
- HW grade: KCR06 (K01-C4)

Pin holes: PH01= 2/10/60

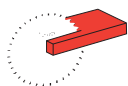

| Item | D | d | B/c | Z | Pin holes |
|--------------------------|-----|----|---------|-----|-----------|
| LE200.06430 🎵 NEW | 200 | 30 | 3,0/2,5 | 64 | |
| LE250.08030 🎵 NEW | 250 | 30 | 3,0/2,5 | 80 | PH01 |
| LE300.09630 🎵 NEW | 300 | 30 | 3,0/2,5 | 96 | PH01 |
| LE350.10830 🎵 NEW | 350 | 30 | 3,2/2,5 | 108 | PH01 |
| LE400.12030 🎵 NEW | 400 | 30 | 3,6/3,0 | 120 | 2/11/63 |
| LE450.12030 🎵 NEW | 450 | 30 | 3,8/3,2 | 120 | 2/11/63 |
| LE500.12030 🎵 NEW | 500 | 30 | 4,0/3,2 | 120 | 2/11/63 |
| LE550.14030 🎵 NEW | 550 | 30 | 4,2/3,5 | 140 | 2/11/63 |
| LE600.14030 🎵 NEW | 600 | 30 | 4,2/3,5 | 140 | 2/11/63 |

HW GROOVING SAWBLADES

ART. KA

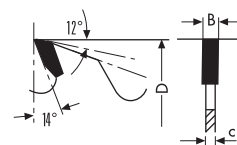

- FZ flat teeth
- For cutting along and across grain of **hardwood, softwood, timber wood, and plastic coated panel**
- For producing grooves
- HW grade: KCR06 (K01-C4)

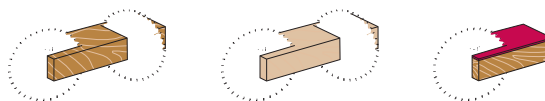

| Item | D | d | B/c | Z |
|---------------|-----|----|----------|----|
| KA125.0123015 | 125 | 30 | 1,5/1,1 | 12 |
| KA125.0123018 | 125 | 30 | 1,8/1,3 | 12 |
| KA125.0123020 | 125 | 30 | 2,0/1,4 | 12 |
| KA125.0123025 | 125 | 30 | 2,5/1,6 | 12 |
| KA125.0123030 | 125 | 30 | 3,0/2,0 | 12 |
| KA125.0123035 | 125 | 30 | 3,5/2,5 | 12 |
| KA125.0123040 | 125 | 30 | 4,0/2,8 | 12 |
| KA125.0123045 | 125 | 30 | 4,5/3,2 | 12 |
| KA125.0123050 | 125 | 30 | 5,0/4,0 | 12 |
| KA125.0123060 | 125 | 30 | 6,0/4,0 | 12 |
| KA125.0123070 | 125 | 30 | 7,0/6,0 | 12 |
| KA125.0123080 | 125 | 30 | 8,0/6,0 | 12 |
| KA125.0123090 | 125 | 30 | 9,0/6,0 | 12 |
| KA125.0123099 | 125 | 30 | 10,0/6,0 | 12 |
| KA150.0183015 | 150 | 30 | 1,5/1,1 | 18 |
| KA150.0183018 | 150 | 30 | 1,8/1,3 | 18 |
| KA150.0183020 | 150 | 30 | 2,0/1,4 | 18 |
| KA150.0183025 | 150 | 30 | 2,5/1,6 | 18 |
| KA150.0183030 | 150 | 30 | 3,0/2,0 | 18 |
| KA150.0183035 | 150 | 30 | 3,5/2,5 | 18 |
| KA150.0183040 | 150 | 30 | 4,0/2,8 | 18 |
| KA150.0183050 | 150 | 30 | 5,0/4,0 | 18 |
| KA150.0183060 | 150 | 30 | 6,0/4,0 | 18 |
| KA150.0183070 | 150 | 30 | 7,0/6,0 | 18 |
| KA150.0183080 | 150 | 30 | 8,0/6,0 | 18 |
| KA150.0183090 | 150 | 30 | 9,0/6,0 | 18 |
| KA150.0183099 | 150 | 30 | 10,0/6,0 | 18 |
| KA180.0243020 | 180 | 30 | 2,0/1,4 | 24 |
| KA180.0243025 | 180 | 30 | 2,5/1,6 | 24 |
| KA180.0243030 | 180 | 30 | 3,0/2,0 | 24 |
| KA180.0243035 | 180 | 30 | 3,5/2,5 | 24 |
| KA180.0243040 | 180 | 30 | 4,0/2,8 | 24 |
| KA180.0243050 | 180 | 30 | 5,0/4,0 | 24 |
| KA180.0243060 | 180 | 30 | 6,0/4,0 | 24 |
| KA180.0243070 | 180 | 30 | 7,0/6,0 | 24 |
| KA180.0243080 | 180 | 30 | 8,0/6,0 | 24 |
| KA180.0243090 | 180 | 30 | 9,0/6,0 | 24 |
| KA180.0243099 | 180 | 30 | 10,0/6,0 | 24 |

HW "DRY" OR "QUATTRO" SAWBLADES

ART. LZ

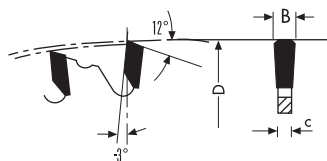

- TR special form of teeth
- 3° **negative** hook angle
- For cutting wood, **ferrous and no-ferrous material, plastic and compound materials**
- For hand saws, mitre-saws and table saws
- HW grade: SMX (P20 - P25 - C6)

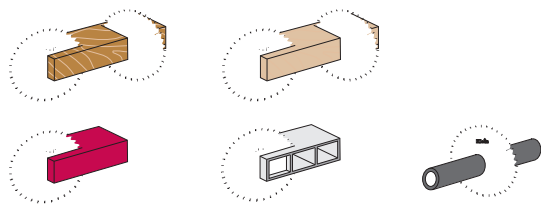

| Item | D | d | B/c | Z | Pin holes |
|-------------|-----|------|---------|----|----------------|
| LZ150.03020 | 150 | 20 | 2,2/1,6 | 30 | |
| LZ160.03020 | 160 | 20 | 2,2/1,6 | 30 | |
| LZ180.03430 | 180 | 30 | 2,2/1,6 | 30 | |
| LZ190.03830 | 190 | 30 | 2,2/1,6 | 38 | |
| LZ200.04030 | 200 | 30 | 2,2/1,6 | 40 | |
| LZ210.04030 | 210 | 30 | 2,2/1,6 | 40 | |
| LZ230.04430 | 230 | 30 | 2,2/1,6 | 40 | 2/7/42 |
| LZ250.04820 | 250 | 20 | 2,4/1,8 | 48 | 2/7/42 |
| LZ250.04830 | 250 | 30 | 2,4/1,8 | 48 | 2/7/42 |
| LZ300.06026 | 300 | 25,4 | 2,4/1,8 | 60 | 2/7/42+2/10/60 |
| LZ300.06030 | 300 | 30 | 2,4/1,8 | 60 | 2/7/42+2/10/60 |
| LZ305.08026 | 305 | 25,4 | 2,4/1,8 | 80 | 2/7/42+2/10/60 |
| LZ350.08030 | 350 | 30 | 2,6/2,0 | 70 | 2/7/42+2/10/60 |
| LZ355.08026 | 355 | 25,4 | 2,6/2,0 | 80 | 2/7/42+2/10/60 |
| LZ400.08430 | 400 | 30 | 3,0/2,0 | 84 | 2/10/60 |

RPM suggested referred to the blade diameter

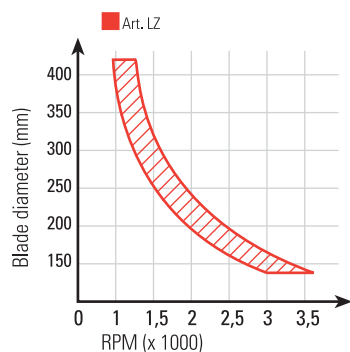

HW SAWBLADES FOR "SOLID SURFACE"

ART. MES

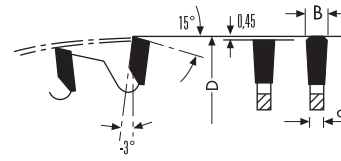

- FZ/TR triple chip teeth
- 3° **negative** hook angle
- Ideal for cutting solid surface "Corian®" "Varicor" ecc
- Suitable for **plexiglass and plastic materials**
- High finishing grade, no scratch, no risk of material melting
- **No-noise**
- HW grade: KCR05 (K01-C4)

Pin holes: PH02= 2/7/42 + 2/9,5/46,5 + 2/10/60

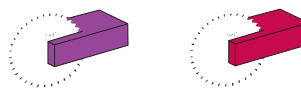

| Item | D | d | B/c | Z | Pin holes |
|--------------|-----|----|---------|-----|-----------|
| MES250.06030 | 250 | 30 | 3,2/2,5 | 60 | PH02 |
| MES250.08030 | 250 | 30 | 3,2/2,5 | 80 | PH02 |
| MES300.08430 | 300 | 30 | 3,2/2,5 | 84 | PH02 |
| MES300.09630 | 300 | 30 | 3,2/2,5 | 96 | PH02 |
| MES350.11230 | 350 | 30 | 3,2/2,5 | 112 | PH02 |

RPM suggested referred to the blade diameter

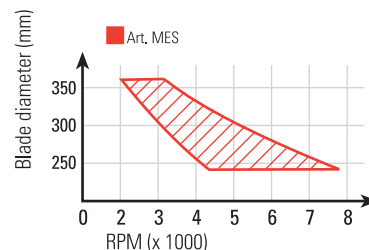

HW SAWBLADES FOR PVC AND PLEXIGLASS

ART. MGS

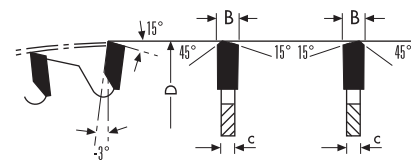

- WZ/FA alternate-trap, teeth
- 3° **negative** hook angle
- Suitable for **thin plastic, plexiglass, PVC and plywood**
- **No-noise**
- HW grade: KCR06 (K01-C4)

Pin holes: PH02= 2/7/42 + 2/9,5/46,5 + 2/10/60

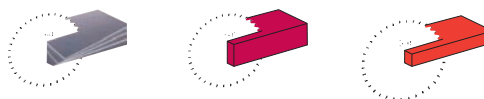

| Item | D | d | B/c | Z | Pin holes |
|--------------|-----|----|---------|----|-----------|
| MGS250.08030 | 250 | 30 | 2,6/2,0 | 80 | PH02 |
| MGS300.08430 | 300 | 30 | 2,6/2,0 | 84 | PH02 |
| MGS300.09630 | 300 | 30 | 2,6/2,0 | 96 | PH02 |

HW SAWBLADES FOR FRAMES

ART. MLS - MMS

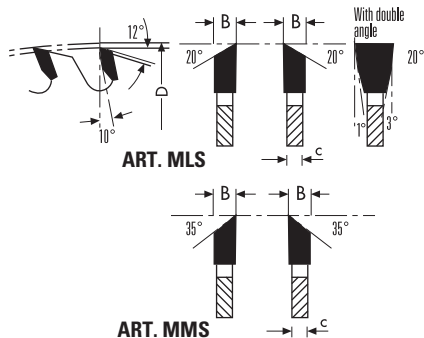

- **WZ** alternate top bevel teeth
- Excellent finish on 45° cut
- **♫** = **No-noise**
- **MLS** excellent for **MDF** and **PVC** frame
- **MMS** for difficult cutting
- **HW** grade: **KCR06 (K01-C4)**

Pin holes: **PH02** = 2/7/42 + 2/9,5/46,5 + 2/10/60

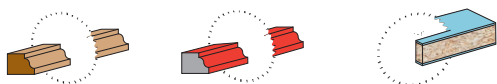

| Item | D | d | B/c | α | Z | Pin holes |
|--------------|-----|----|---------|-----|----|-----------|
| MLS250.08030 | 250 | 30 | 3,0/2,5 | 20° | 80 | PH02 |
| MLS300.09630 | 300 | 30 | 3,0/2,5 | 20° | 96 | PH02 |
| MMS300.09630 | 300 | 30 | 3,0/2,5 | 35° | 96 | PH02 |

HW SAWBLADES FOR "SANDWICH" PANELS

ART. MP

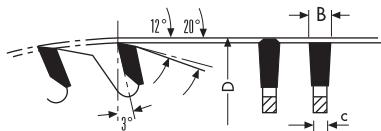

- **FZ/TR** triple chip teeth
- **HW** grade: **SMX (P20 - P25 - C6)**

Pin holes: **PH01** = 2/10/60

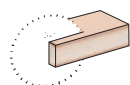

| Item | D | d | B/c | Z | Pin holes |
|-------------|-----|----|---------|-----|-----------|
| MP250.08030 | 250 | 30 | 2,8/2,2 | 80 | |
| MP300.09630 | 300 | 30 | 2,8/2,2 | 96 | PH01 |
| MP350.10830 | 350 | 30 | 3,2/2,6 | 108 | PH01 |
| MP400.10830 | 400 | 30 | 3,4/2,8 | 108 | PH01 |
| MP450.12030 | 450 | 30 | 3,6/3,0 | 120 | |
| MP500.12040 | 500 | 40 | 3,8/3,2 | 120 | |
| MP550.14040 | 550 | 40 | 4,2/3,6 | 140 | |
| MP600.14440 | 600 | 40 | 4,2/3,6 | 144 | |

HW DM05 SAWBLADES FOR FERROUS MATERIALS

ART. PA - PB

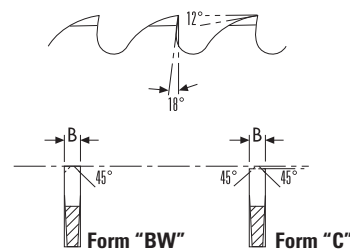

- **Vaporized** execution for steel, pipe, ferrous materials
- Fit for low RPM table saws
- Art. **PA** = form "C"
- Art. **PB** = form "BW"

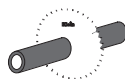

| Item | D | d | B | Form | Z | Pin holes |
|-------------|-----|----|-----|------|-----|-----------------------|
| PA225.12032 | 225 | 32 | 2,0 | C | 120 | 2/8/45+2/11/63+2/9/50 |
| PA225.12040 | 225 | 40 | 2,0 | C | 120 | 2/8/55+4/12/64 |
| PB225.18032 | 225 | 32 | 2,0 | BW | 180 | 2/8/45+2/11/63+2/9/50 |
| PB225.18040 | 225 | 40 | 2,0 | BW | 180 | 2/8/55+4/12/64 |
| PA250.12832 | 250 | 32 | 2,0 | C | 128 | 2/8/45+2/11/63+2/9/50 |
| PA250.12840 | 250 | 40 | 2,0 | C | 128 | 2/8/55+4/12/64 |
| PB250.20032 | 250 | 32 | 2,0 | BW | 200 | 2/8/45+2/11/63+2/9/50 |
| PB250.20040 | 250 | 40 | 2,0 | BW | 200 | 2/8/55+4/12/64 |
| PA275.14032 | 275 | 32 | 2,5 | C | 140 | 2/8/45+2/11/63+2/9/50 |
| PA275.14040 | 275 | 40 | 2,5 | C | 140 | 2/8/55+4/12/64 |
| PB275.22032 | 275 | 32 | 2,5 | BW | 220 | 2/8/45+2/11/63+2/9/50 |
| PB275.22040 | 275 | 40 | 2,5 | BW | 220 | 2/8/55+4/12/64 |
| PA300.16032 | 300 | 32 | 2,5 | C | 160 | 2/8/45+2/11/63+2/9/50 |
| PA300.16040 | 300 | 40 | 2,5 | C | 160 | 2/8/55+4/12/64 |
| PB300.22032 | 300 | 32 | 2,5 | BW | 220 | 2/8/45+2/11/63+2/9/50 |
| PB300.22040 | 300 | 40 | 2,5 | BW | 220 | 2/8/55+4/12/64 |
| PA315.16032 | 315 | 32 | 2,5 | C | 160 | 2/8/45+2/11/63+2/9/50 |
| PA315.16040 | 315 | 40 | 2,5 | C | 160 | 2/8/55+4/12/64 |
| PB315.22032 | 315 | 32 | 2,5 | BW | 220 | 2/8/45+2/11/63+2/9/50 |
| PB315.22040 | 315 | 40 | 2,5 | BW | 220 | 2/8/55+4/12/64 |
| PA325.16040 | 325 | 40 | 2,5 | C | 160 | 2/8/55+4/12/64 |
| PA350.18032 | 350 | 32 | 2,5 | C | 180 | 2/8/45+2/11/63+2/9/50 |
| PA350.18040 | 350 | 40 | 2,5 | C | 180 | 2/8/55+4/12/64 |
| PB350.28032 | 350 | 32 | 2,5 | BW | 280 | 2/8/45+2/11/63+2/9/50 |
| PB350.28040 | 350 | 40 | 2,5 | BW | 280 | 2/8/55+4/12/64 |
| PA370.19040 | 370 | 40 | 3,0 | C | 190 | 2/8/55+4/12/64 |
| PA400.16040 | 400 | 40 | 3,0 | C | 160 | 2/8/55+4/12/64 |

DP SAWBLADES

ART. XFC

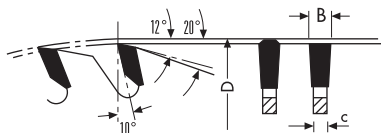

- (FZ/TR) DP triple chip teeth
- For cutting along and across grain of **softwoods, hardwood and exotic timber, double-side veneer laminate boards, MDF and plywood**
- Tooth height **H= 4 mm**

Pin holes: PH02= 2/7/42 + 2/9,5/46,5 + 2/10/60

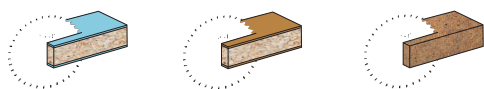

| Item | D | d | B/c | Z | Pin holes |
|--------------|-----|----|---------|----|-----------|
| XFC250.04830 | 250 | 30 | 3,2/2,2 | 48 | PH02 |
| XFC250.06030 | 250 | 30 | 3,2/2,2 | 60 | PH02 |
| XFC300.06030 | 300 | 30 | 3,2/2,2 | 60 | PH02 |
| XFC300.07230 | 300 | 30 | 3,2/2,2 | 72 | PH02 |
| XFC350.07230 | 350 | 30 | 3,5/2,5 | 72 | PH02 |
| XFC350.08430 | 350 | 30 | 3,5/2,5 | 84 | PH02 |
| XFC350.09630 | 350 | 30 | 3,5/2,5 | 96 | PH02 |



CONTACT US
 (+39) 0721 28950
 info@sistemiklein.com

DP CONICAL SCORING SAWBLADES

ART. XFI

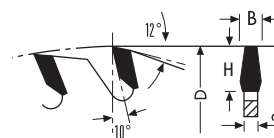

- (KON/FZ) DP conical teeth
- For cutting along and across grain of **softwoods, hardwood and exotic timber, double-side veneer laminate boards, MDF and plywood**
- Tooth height **H= 2,5 mm**

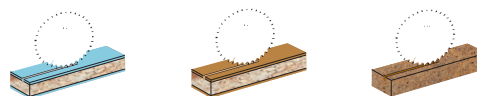

| Item | D | d | B/c | Z | Pin holes |
|--------------|-----|----|-------------|----|-----------|
| XFI120.02020 | 120 | 20 | 3,1-3,7/2,2 | 20 | |
| XFI120.02022 | 120 | 22 | 3,1-3,7/2,2 | 20 | |
| XFI125.02420 | 125 | 20 | 3,1-3,7/2,2 | 20 | |
| XFI125.02422 | 125 | 22 | 3,1-3,7/2,2 | 20 | |
| XFI160.03645 | 160 | 45 | 4,4-5,0/3,2 | 36 | Giben |
| XFI160.03655 | 160 | 55 | 4,4-5,0/3,2 | 36 | Gabbiani |
| XFI180.03620 | 180 | 20 | 4,4-5,0/3,2 | 36 | |
| XFI180.03645 | 180 | 45 | 4,4-5,0/3,2 | 36 | Holzma |
| XFI180.04450 | 180 | 50 | 4,4-5,0/3,2 | 44 | Giben |
| XFI181.03645 | 180 | 45 | 4,8-5,6/3,5 | 36 | Holzma |
| XFI182.03620 | 180 | 20 | 5,8-6,6/4,0 | 36 | Anthon |
| XFI200.03620 | 200 | 20 | 4,4-5,0/3,2 | 36 | |
| XFI200.03630 | 200 | 30 | 4,4-5,0/3,2 | 36 | |
| XFI200.03645 | 200 | 45 | 4,4-5,0/3,2 | 36 | Holzma |
| XFI200.03665 | 200 | 65 | 4,4-5,0/3,2 | 36 | Selco |
| XFI201.03645 | 200 | 45 | 4,8-5,6/3,5 | 36 | Holzma |
| XFI201.03665 | 200 | 65 | 4,8-5,6/3,5 | 36 | Selco |
| XFI202.03620 | 200 | 20 | 5,0-5,8/3,5 | 36 | Schelling |
| XFI203.03645 | 200 | 45 | 5,8-6,6/4,0 | 36 | Holzma |
| XFI215.04250 | 215 | 50 | 4,4-5,0/3,2 | 42 | Giben |

DP ADJUSTABLE SCORING SAWBLADES

ART. XFL

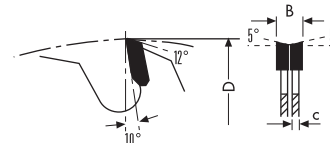

- (LFZ) DP flat teeth
- Supplied with spacers
- For cutting along and across grain of **softwoods, hardwood and exotic timber, double-side veneer laminate boards, MDF and plywood**
- For panel sizing machines
- Tooth height **H= 2,5 mm**

| Item | D | d | B/c | Z |
|--------------|-----|----|-------------|-------|
| XFL125.01020 | 125 | 20 | 2,8-3,4/2,2 | 10+10 |
| XFL125.01022 | 125 | 22 | 2,8-3,4/2,2 | 10+10 |

DP PANEL SIZING SAWBLADES

ART. XHC

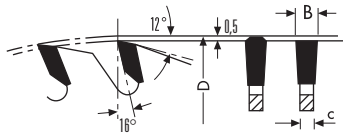

- (FZ/TR) DP triple chip teeth
- For cutting along and across grain of **softwoods, hardwood and exotic timber, double-side veneer laminate boards, MDF and plywood**
- Tooth height **H= 4 mm** (can be produced also with H= 5/6 mm)

Pin holes:

PH02= 2/7/42 + 2/9,5/46,5 + 2/10/60

PH04= 2/14/110 + 2/7/110 + 4/9/100 + 4/19/120 + 2/9/130 (Selco-Gabbiani-SCM)

PH05= 4/15/105 + 3/7/100 (Giben-Homag-MacMazza)

| Item | D | d | B/c | Z | Pin holes |
|--------------|-----|----|---------|----|-------------|
| XHC300.06030 | 300 | 30 | 4,4/3,2 | 60 | PH02 |
| XHC300.06065 | 300 | 65 | 4,4/3,2 | 60 | Selco |
| XHC320.06050 | 320 | 50 | 4,4/3,2 | 60 | Giben |
| XHC320.06065 | 320 | 65 | 4,4/3,2 | 60 | Selco |
| XHC330.06050 | 330 | 50 | 4,4/3,2 | 60 | Giben |
| XHC350.07230 | 350 | 30 | 4,4/3,2 | 72 | PH02 |
| XHC350.07250 | 350 | 50 | 4,4/3,2 | 72 | Giben |
| XHC350.07260 | 350 | 60 | 4,4/3,2 | 72 | Holzma |
| XHC350.07265 | 350 | 65 | 4,4/3,2 | 72 | Selco |
| XHC350.07275 | 350 | 75 | 4,4/3,2 | 72 | PH05 |
| XHC350.07280 | 350 | 80 | 4,4/3,2 | 72 | PH04 |
| XHC360.07250 | 360 | 50 | 4,4/3,2 | 72 | Giben |
| XHC360.07265 | 360 | 65 | 4,4/3,2 | 72 | Selco |
| XHC370.07230 | 370 | 30 | 4,4/3,2 | 72 | PH02 |
| XHC380.07260 | 380 | 60 | 4,8/3,5 | 72 | Holzma |
| XHC400.07230 | 400 | 30 | 4,4/3,2 | 72 | 2/10/60 |
| XHC400.07260 | 400 | 60 | 4,4/3,2 | 72 | Anthon |
| XHC400.07275 | 400 | 75 | 4,4/3,2 | 72 | Giben-Homag |
| XHC400.07280 | 400 | 80 | 4,4/3,2 | 72 | PH04 |
| XHC401.07260 | 400 | 60 | 4,8/3,5 | 72 | Holzma |
| XHC420.07260 | 420 | 60 | 4,8/3,5 | 72 | Holzma |
| XHC430.07275 | 430 | 75 | 4,8/3,5 | 72 | Giben |
| XHC430.07280 | 430 | 80 | 4,8/3,5 | 72 | PH04 |
| XHC450.07230 | 450 | 30 | 4,4/3,2 | 72 | Schelling |
| XHC450.07280 | 450 | 80 | 4,4/3,2 | 72 | PH04 |
| XHC451.07260 | 450 | 60 | 4,8/3,5 | 72 | Holzma |
| XHC451.07280 | 450 | 80 | 4,8/3,5 | 72 | PH04 |
| XHC460.07230 | 460 | 30 | 4,4/3,2 | 72 | Schelling |
| XHC470.07275 | 470 | 75 | 4,4/3,2 | 72 | Giben |
| XHC480.07230 | 480 | 30 | 4,4/3,2 | 72 | Schelling |
| XHC481.07260 | 480 | 60 | 4,8/3,5 | 72 | Holzma |
| XHC481.07280 | 480 | 80 | 4,8/3,5 | 72 | Selco |
| XHC500.07260 | 500 | 60 | 4,8/3,5 | 72 | Holzma |
| XHC520.07260 | 520 | 60 | 4,8/3,5 | 60 | Holzma |

DP SAWBLADES FOR CUTTING ABRASIVE MATERIALS

ART. XGE

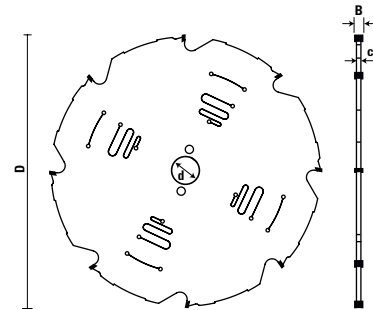

- Suitable for cutting **cement fiber, plasterboards, fiber reinforced plastics, solid surface and Eternit**
- DP flat teeth
- DP tooth height **3,5 mm**
- = No-noise

Pin holes: **PH02**= 2/7/42 + 2/9,5/46,5 + 2/10/60

| Item | D | d | B/c | Z | Pin holes |
|-------------------------|-----|----|---------|----|-----------|
| XGE160.10420 NEW | 160 | 20 | 2,4/1,6 | 4 | 2/6/32 |
| XGE160.10820 NEW | 160 | 20 | 2,4/1,6 | 8 | 2/6/32 |
| XGE190.10420 NEW | 190 | 20 | 2,4/1,6 | 4 | 2/6/32 |
| XGE200.10430 NEW | 200 | 30 | 2,4/1,6 | 4 | 2/7/42 |
| XGE200.10830 NEW | 200 | 30 | 2,4/1,6 | 8 | 2/7/42 |
| XGE216.10830 NEW | 216 | 30 | 2,4/1,6 | 8 | - |
| XGE230.10630 NEW | 230 | 30 | 2,4/1,6 | 6 | 2/7/42 |
| XGE250.10630 NEW | 250 | 30 | 2,4/1,6 | 6 | PH02 |
| XGE250.11230 NEW | 250 | 30 | 2,4/1,6 | 12 | PH02 |
| XGE300.11230 NEW | 300 | 30 | 2,4/1,6 | 12 | PH02 |
| XGE300.12030 NEW | 300 | 30 | 2,4/1,6 | 20 | PH02 |

REDUCTION RINGS FOR SAWBLADES

ART. ZA

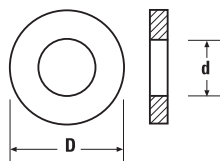

| Item | D | d |
|-------------|----|------|
| ZA000.02012 | 20 | 12,7 |
| ZA000.02013 | 20 | 13 |
| ZA000.02015 | 20 | 15 |
| ZA000.02016 | 20 | 16 |
| ZA000.03015 | 30 | 15 |
| ZA000.03016 | 30 | 16 |
| ZA000.03020 | 30 | 20 |
| ZA000.03025 | 30 | 25 |
| ZA000.03026 | 30 | 25,4 |
| ZA000.03028 | 30 | 28,6 |
| ZA000.03220 | 32 | 20 |
| ZA000.03230 | 32 | 30 |
| ZA000.03516 | 35 | 16 |
| ZA000.03520 | 35 | 20 |
| ZA000.03526 | 35 | 26 |
| ZA000.03530 | 35 | 30 |
| ZA000.03532 | 35 | 32 |
| ZA000.04030 | 40 | 30 |
| ZA000.04032 | 40 | 32 |
| ZA000.04035 | 40 | 35 |

SPECIAL SAWBLADE REBORING

ART. AF

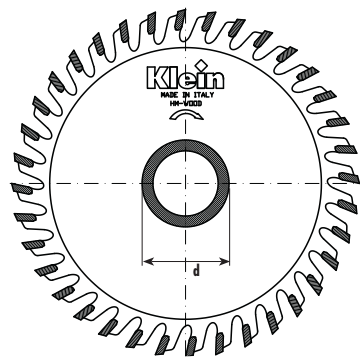

- Specify diameter (d)
- **Reboring is never recommended**
- **Maximum reboring of the blade is 20 mm of the original bore size**

| Item | pcs. |
|------------|------|
| LAME.AF.x1 | 1 |
| LAME.AF.x2 | 2 |
| LAME.AF.x3 | 3 |

SAFETY PIN HOLES FOR SAWBLADES

ART. FT

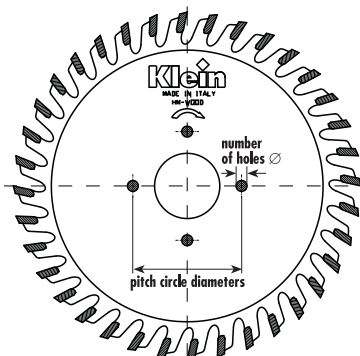

Specify number of pin holes, sawblade diameter and pitch circle diameters

| Item | pcs. |
|------------|------|
| LAME.FT.x1 | 1 |
| LAME.FT.x2 | 2 |
| LAME.FT.x3 | 3 |

Cutterheads

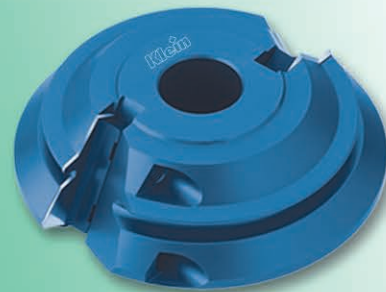

13



HW "LAMELLO"[®] - GROOVE CUTTER
Page 13.03



HW "LAMELLO"[®] - GROOVE CUTTER
Page 13.03



HW ADJUSTABLE GROOVE CUTTER
Page 13.03



HS CUTTERHEADS B=40
WITH CHIP LIMITERS
Page 13.04



HS CUTTERHEADS B=40
WITHOUT CHIP LIMITERS
Page 13.04



LIGHT ALLOY CUTTERHEADS
B=40-50 WITH CHIP LIMITERS
Page 13.05



LIGHT ALLOY CUTTERHEADS B=40-50
WITHOUT CHIP LIMITERS
Page 13.05



BLANK KNIVES AND LIMITERS IN
"SP" STEEL
Page 13.05



7 PROFILE CUTTERHEAD SETS WITH
KNIVES AND CHIP LIMITERS
(PROFILES 0-6)
Page 13.06



7 PROFILE CUTTERHEAD SETS
WITH KNIVES (PROFILES 0-6)
Page 13.06



13 PROFILE CUTTERHEAD SETS WITH
KNIVES AND CHIP LIMITERS
(PROFILES 0-12)
Page 13.07



13 PROFILE CUTTERHEAD SETS
WITH KNIVES (PROFILES 0-12)
Page 13.07



13 PROFILE CUTTERHEAD SETS
WITH KNIVES AND CHIP LIMITERS
(PROFILES 13-24)
Page 13.08



13 PROFILE CUTTERHEAD SETS
WITH KNIVES (PROFILES 13-24)
Page 13.08



13 PROFILE CUTTERHEAD SETS WITH
KNIVES AND CHIP LIMITERS
(PROFILES 25-36)
Page 13.09



13 PROFILE CUTTERHEAD SETS
WITH KNIVES (PROFILES 25-36)
Page 13.09

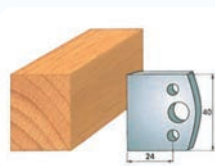

STANDARD PROFILE KNIVES
(SA0) and Limiters (SA1) - h 40x4
Page 13.10-13.15

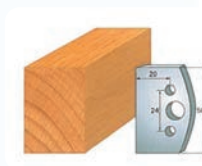

STANDARD PROFILE KNIVES
(SA2) and Limiters (SA3) - h 50x4
Page 13.16-13.20





HW ADJUSTABLE CUTTERHEAD WITH REVERSIBLE KNIVES FOR GROOVES
Page 13.21



HW CUTTERHEADS WITH REVERSIBLE KNIVES FOR "LAMELLO"
Page 13.22



HW ADJUSTABLE CUTTERHEAD WITH REVERSIBLE KNIVES FOR GROOVES
Page 13.22



HW ADJUSTABLE GROOVING CUTTERHEAD FOR TENONS
Page 13.23



HW CUTTERHEAD WITH REVERSIBLE STRAIGHT KNIVES AND SPURS
Page 13.23



HW CUTTERHEAD WITH REVERSIBLE STRAIGHT KNIVES AND SPURS
Page 13.24



REBATING-GROOVING SET
Page 13.25



HW CUTTERHEAD FOR 45° BEVELS
Page 13.25



HW ADJUSTABLE BEVEL CUTTERHEAD
Page 13.26

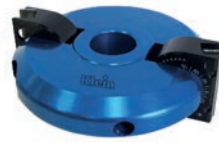

HW ADJUSTABLE BEVEL CUTTERHEAD
Page 13.26



HW TOOLING SET FOR ROUNDING AND CHAMFERING
Page 13.27



HW MULTIRADIUS SET
Page 13.28



HW TOOLING SET FOR CONCAVE AND CONVEX QUARTER ROUNDS
Page 13.29



MULTIPROFILE SET
Page 13.30 - 13.33



HW MITRE JOINT CUTTERHEAD 45°
Page 13.34



HW PROFILE CUTTER
Page 13.34



HW PANEL RAISING SET WITH SIX PROFILES
Page 13.35, 13.36



HW PANEL RAISING SET
Page 13.36



HW PANEL RAISING SET
Page 13.37



HW PANEL RAISING SET
Page 13.38



COUNTERPROFILE-RAISING PANEL SET
Page 13.38



HW TOOLING SET FOR PROFILES AND COUNTERPROFILES
Page 13.39 ÷ 13.41



TONGUE AND GROOVE TOOLING SET
Page 13.42



PLANERHEAD
Page 13.43



GUIDE BALL BEARINGS FOR SAWING OUT
Page 13.43



GUIDE RINGS FOR BALL BEARING
Page 13.43



REDUCTION RINGS FOR CUTTERHEADS AND REDUCING BUSHES
Page 13.44



BALL BEARING WITH BUTTING RING SET
Page 13.44

HW "LAMELLO"®- GROOVE CUTTER

ART. AH

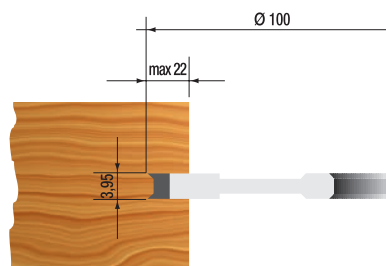

- T.C.T. brazed cutter with spurs for making Lamello® grooves on any kind of wood
- For hand milling machines
- Manual feed (MAN)

| Item | D | d | B | Z | V |
|-------------|-----|----|------|---|---|
| AH100.20622 | 100 | 22 | 3,95 | 2 | 4 |

HW "LAMELLO"®- GROOVE CUTTER

ART. RA

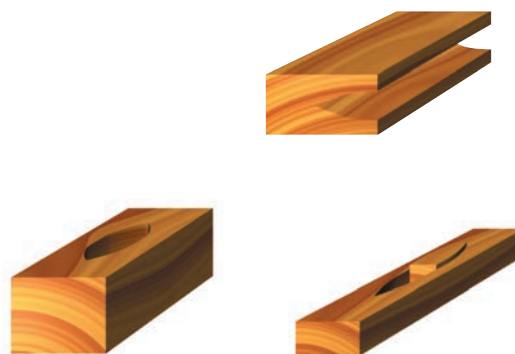
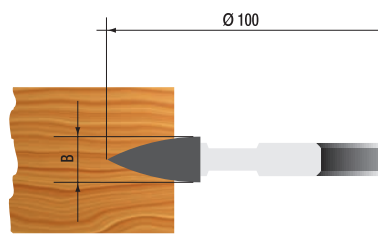

- T.C.T. brazed cutters for manual feed for Lamello® hand milling machines
- Manual feed (MAN)

| Item | D | d | B | Z |
|-------------|-----|----|----|---|
| RA100.08022 | 100 | 22 | 8 | 4 |
| RA100.15022 | 100 | 22 | 15 | 4 |

HW ADJUSTABLE GROOVE CUTTER

ART. RA

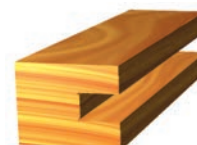
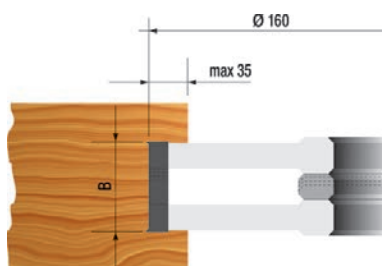

- T.C.T. brazed cutter with spurs for precision grooves
- Manual feed (MAN)

| Item | D | d | B | Z | V |
|-------------|-----|----|--------|---|---|
| RA160.07530 | 160 | 30 | 4÷7,5 | 4 | 4 |
| RA160.14030 | 160 | 30 | 7,5÷14 | 4 | 4 |

STEEL CUTTERHEADS B=40 WITH CHIP LIMITERS

ART. SA

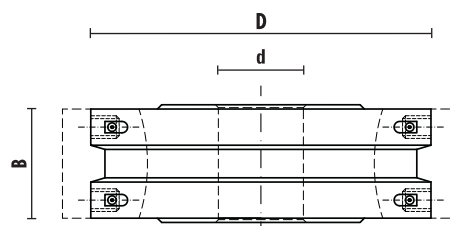

- Tool body in steel
- Equipped with SP knives and chip limiters profile "0"
- For spindle moulders with manual feed (MAN)
- To be used with knives **B=40x4 mm** (Art. SA0 page 13.10÷13.15) and chip limiters (Art. SA1 page 13.10÷13.15)
- For solid wood

| Item | D | d | B | Z | n min | n max |
|-------------|-----|----|----|---|-------|-------|
| SA078.40030 | 78 | 30 | 40 | 2 | 7000 | 9000 |
| SA093.40030 | 93 | 30 | 40 | 2 | 5800 | 8600 |
| SA100.40030 | 100 | 30 | 40 | 2 | 5500 | 8400 |
| SA120.40030 | 120 | 30 | 40 | 2 | 4800 | 7700 |
| SA120.40035 | 120 | 35 | 40 | 2 | 4800 | 7700 |
| SA120.40050 | 120 | 50 | 40 | 2 | 4800 | 7700 |



Z056.790.R



Z051.704.R



Z052.003.R

STEEL CUTTERHEADS B=40 WITHOUT CHIP LIMITERS

ART. SA

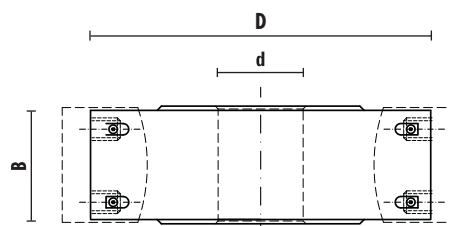

- Tool body in steel
- Equipped with SP knives profile "0"
- For spindle moulders with mechanical feed (MEC)
- To be used with knives **B=40x4 mm** (Art. SA0 page 13.10÷13.15)

| Item | D | d | B | Z | n min | n max |
|-------------|-----|----|----|---|-------|-------|
| SA078.40130 | 78 | 30 | 40 | 2 | 7000 | 9000 |
| SA093.40130 | 93 | 30 | 40 | 2 | 5800 | 8600 |
| SA100.40130 | 100 | 30 | 40 | 2 | 5500 | 8400 |
| SA120.40135 | 120 | 35 | 40 | 2 | 4800 | 7700 |
| SA120.40150 | 120 | 50 | 40 | 2 | 4800 | 7700 |



Z056.791.R



Z051.705.R



Z052.003.R

LIGHT ALLOY CUTTERHEADS B=40÷50 WITH CHIP LIMITERS

ART. SAL

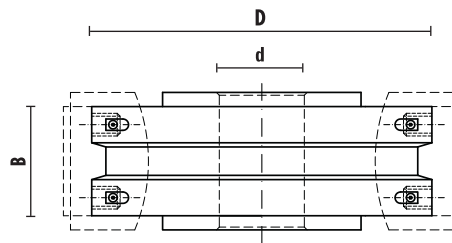

- Tool body in light alloy
- Equipped with SP knives and chip limiters profile "0"
- For spindle moulders with manual feed (MAN)
- To be used with knives **B=40x4 mm** (Art. SA0 page 13.10÷13.15) and chip limiters (Art. SA1 page 13.10÷13.15) or **B=50x4 mm** (Art. SA2 page 13.16÷13.20) and chip limiters (Art. SA3 page 13.16÷13.20)

| Item | D | d | B | Z | n min | n max |
|--------------|-----|----|-------|---|-------|-------|
| SAL100.45030 | 100 | 30 | 40÷50 | 2 | 5500 | 8400 |
| SAL120.45035 | 120 | 35 | 40÷50 | 2 | 4800 | 7400 |
| SAL120.45050 | 120 | 50 | 40÷50 | 2 | 4800 | 7400 |



Z056.790.R



Z051.704.R



Z052.003.R

LIGHT ALLOY CUTTERHEADS B=40÷50 WITHOUT CHIP LIMITERS

ART. SAL

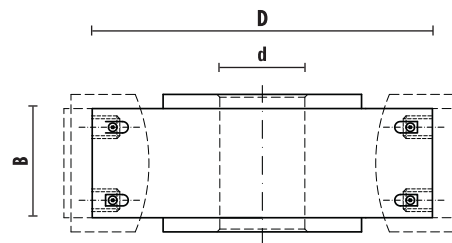

- Tool body in light alloy
- Equipped with SP knives and chip limiters profile "0"
- For spindle moulders with mechanical feed (MEC)
- To be used with knives **B=40x4 mm** (Art. SA0 page 13.10÷13.15) or **B=50x4 mm** (Art. SA2 page 13.16÷13.20)

| Item | D | d | B | Z | n min | n max |
|--------------|-----|----|-------|---|-------|-------|
| SAL100.45130 | 100 | 30 | 40÷50 | 2 | 5500 | 8400 |
| SAL120.45135 | 120 | 35 | 40÷50 | 2 | 4800 | 7400 |
| SAL120.45150 | 120 | 50 | 40÷50 | 2 | 4800 | 7400 |



Z056.791.R



Z051.705.R



Z052.003.R

BLANK KNIVES AND LIMITERS IN "SP" STEEL

ART. SA

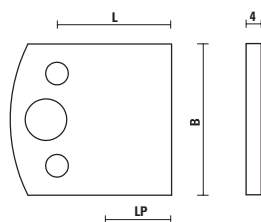

- They have to be sharpened within "LP" dimension
- Sold in pairs
- Full range at page 13.10

| Item | B | L | C | LP | Type |
|-------------------|----|------|---|----|---------|
| SA000X NEW | 40 | 33,5 | 4 | 18 | Knife |
| SA100X NEW | 38 | 32,5 | 4 | 18 | Limiter |
| SA200X NEW | 50 | 34 | 4 | 20 | Knife |
| SA300X NEW | 48 | 33 | 4 | 20 | Limiter |

7 PROFILE CUTTERHEAD SETS WITH KNIVES AND CHIP LIMITERS (PROFILES 0÷6)

ART. SX001 - SXL001

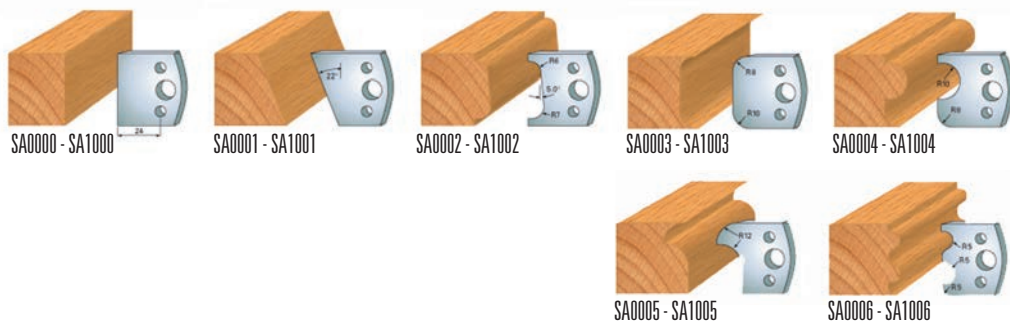

- Set in plastic box complete with cutterhead, **SP steel knives and chip limiters profiles 0÷6**
- Cutterhead Z=2 tool body in steel (**Art. SX**)
- Cutterhead Z=2 tool body in light alloy (**Art. SXL**)
- For spindle moulders with manual feed (MAN)

Item

| | |
|------------------|---|
| SX001.078.40030 | Complete with cutterhead in steel body D=78 - Bore 30 - B=40 (Art. SA078.40030) + Profiles and chip limiters 0÷6 |
| SX001.093.40030 | Complete with cutterhead in steel body D=93 - Bore 30 - B=40 (Art. SA093.40030) + Profiles and chip limiters 0÷6 |
| SX001.100.40030 | Complete with cutterhead in steel body D=100 - Bore 30 - B=40 (Art. SA100.40030) + Profiles and chip limiters 0÷6 |
| SX001.120.40035 | Complete with cutterhead in steel body D=120 - Bore 35 - B=40 (Art. SA120.40035) + Profiles and chip limiters 0÷6 |
| SX001.120.40050 | Complete with cutterhead in steel body D=120 - Bore 50 - B=40 (Art. SA120.40050) + Profiles and chip limiters 0÷6 |
| SXL001.100.45030 | Complete with cutterhead in light alloy body D=100 - Bore 30 - B=40÷50 (Art. SAL100.45030) + Profiles and chip limiters 0÷6 |
| SXL001.120.45035 | Complete with cutterhead in light alloy body D=120 - Bore 35 - B=40÷50 (Art. SAL120.45035) + Profiles and chip limiters 0÷6 |
| SXL001.120.45050 | Complete with cutterhead in light alloy body D=120 - Bore 50 - B=40÷50 (Art. SAL120.45050) + Profiles and chip limiters 0÷6 |

7 PROFILE CUTTERHEAD SETS WITH KNIVES (PROFILES 0÷6)

ART. SX001 - SXL001

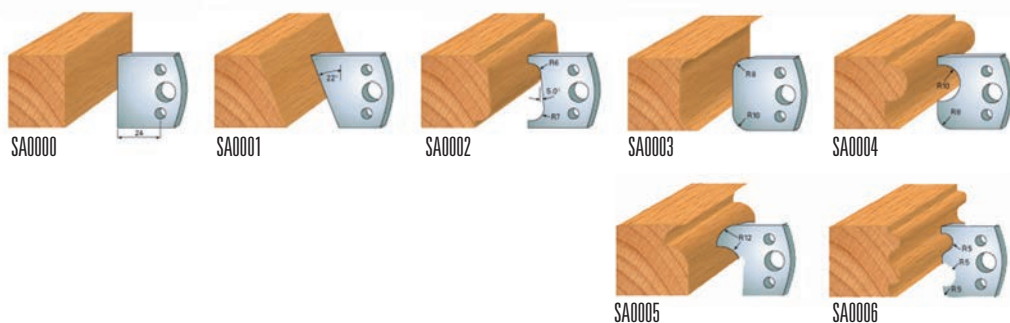

- Set in plastic box complete with cutterheads and SP steel knives 0÷6 (**without chip limiters**)
- Cutterhead Z=2 tool body in steel (**Art. SX**)
- Cutterhead Z=2 tool body in light alloy (**Art. SXL**)
- For spindle moulders with mechanical feed (MEC)

Item

| | |
|------------------|---|
| SX001.078.40130 | Complete with cutterhead in steel body D=78 - Bore 30 - B=40 (Art. SA078.40130) + Profiles 0÷6 |
| SX001.093.40130 | Complete with cutterhead in steel body D=93 - Bore 30 - B=40 (Art. SA093.40130) + Profiles 0÷6 |
| SX001.100.40130 | Complete with cutterhead in steel body D=100 - Bore 30 - B=40 (Art. SA100.40130) + Profiles 0÷6 |
| SX001.120.40135 | Complete with cutterhead in steel body D=120 - Bore 35 - B=40 (Art. SA120.40135) + Profiles 0÷6 |
| SX001.120.40150 | Complete with cutterhead in steel body D=120 - Bore 50 - B=40 (Art. SA120.40150) + Profiles 0÷6 |
| SXL001.100.45130 | Complete with cutterhead in light alloy body D=100 - Bore 30 - B=40÷50 (Art. SAL100.45130) + Profiles 0÷6 |
| SXL001.120.45135 | Complete with cutterhead in light alloy body D=120 - Bore 35 - B=40÷50 (Art. SAL120.45135) + Profiles 0÷6 |
| SXL001.120.45150 | Complete with cutterhead in light alloy body D=120 - Bore 50 - B=40÷50 (Art. SAL120.45150) + Profiles 0÷6 |

13 PROFILE CUTTERHEAD SETS WITH KNIVES AND CHIP LIMITERS (PROFILES 0÷12)

ART. SX002 - SXL002

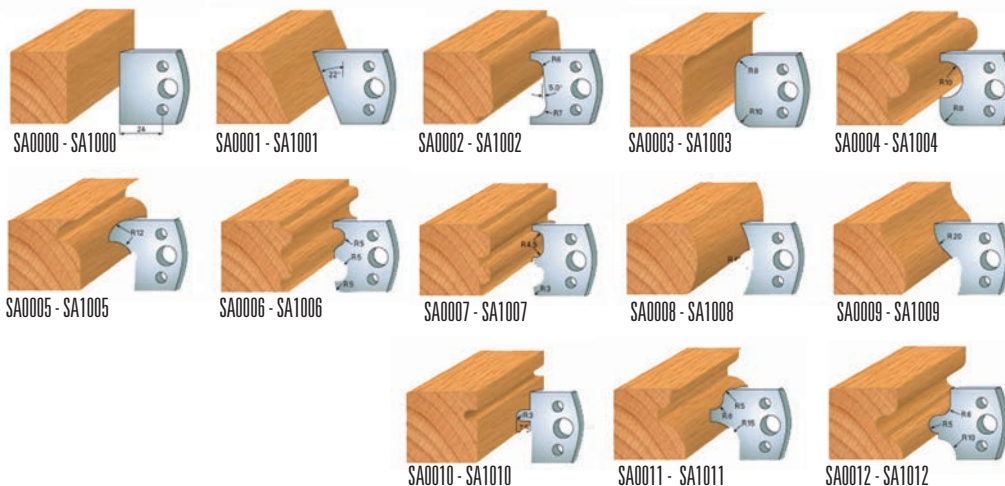

- Set in plastic box complete with cutterheads, **SP steel knives and chip limiters profile 0÷12**
- Cutterhead Z=2 tool body in steel (**Art. SX**)
- Cutterhead Z=2 tool body in light alloy (**Art. SXL**)
- For spindle moulders with manual feed (MAN)

| Item | Description |
|------------------|--|
| SX002.078.40030 | Complete with cutterhead in steel body D=78 - Bore 30 - B=40 (Art. SA078.40030) + Profiles and chip limiters 0÷12 |
| SX002.093.40030 | Complete with cutterhead in steel body D=93 - Bore 30 - B=40 (Art. SA093.40030) + Profiles and chip limiters 0÷12 |
| SX002.100.40030 | Complete with cutterhead in steel body D=100 - Bore 30 - B=40 (Art. SA100.40030) + Profiles and chip limiters 0÷12 |
| SX002.120.40035 | Complete with cutterhead in steel body D=120 - Bore 35 - B=40 (Art. SA120.40035) + Profiles and chip limiters 0÷12 |
| SX002.120.40050 | Complete with cutterhead in steel body D=120 - Bore 50 - B=40 (Art. SA120.40050) + Profiles and chip limiters 0÷12 |
| SXL002.100.45030 | Complete with cutterhead in light alloy body D=100 - Bore 30 - B=40÷50 (Art. SAL100.45030) + Profiles and chip limiters 0÷12 |
| SXL002.120.45035 | Complete with cutterhead in light alloy body D=120 - Bore 35 - B=40÷50 (Art. SAL120.45035) + Profiles and chip limiters 0÷12 |
| SXL002.120.45050 | Complete with cutterhead in light alloy body D=120 - Bore 50 - B=40÷50 (Art. SAL120.45050) + Profiles and chip limiters 0÷12 |

13 PROFILE CUTTERHEAD SETS WITH KNIVES (PROFILES 0÷12)

ART. SX002 - SXL002

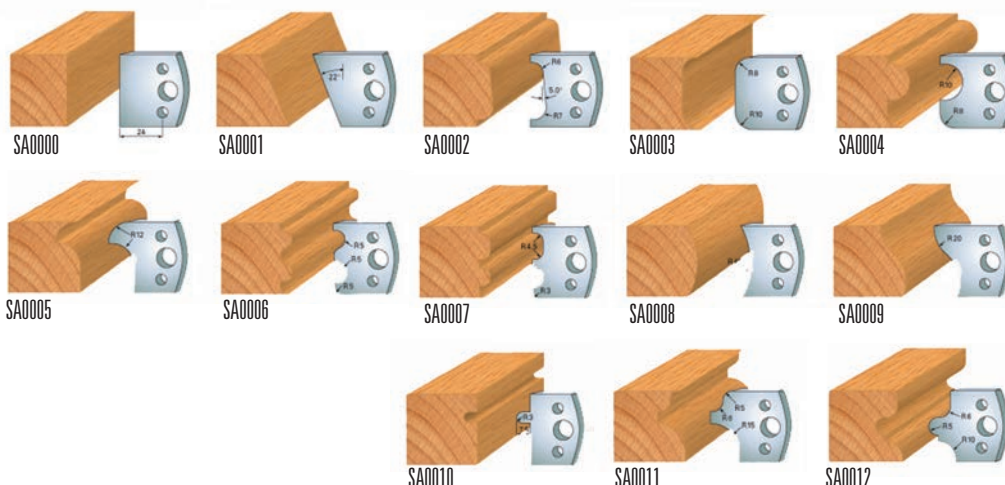

- Set in plastic box complete with cutterheads and SP steel knives 0÷12 (**without chip limiters**)
- Cutterhead Z=2 tool body in steel (**Art. SX**)
- Cutterhead Z=2 tool body in light alloy (**Art. SXL**)
- For spindle moulders with mechanical feed (MEC)

| Item | Description |
|------------------|--|
| SX002.078.40130 | Complete with cutterhead in steel body D=78 - Bore 30 - B=40 (Art. SA078.40130) + Profiles 0÷12 |
| SX002.093.40130 | Complete with cutterhead in steel body D=93 - Bore 30 - B=40 (Art. SA093.40130) + Profiles 0÷12 |
| SX002.100.40130 | Complete with cutterhead in steel body D=100 - Bore 30 - B=40 (Art. SA100.40130) + Profiles 0÷12 |
| SX002.120.40135 | Complete with cutterhead in steel body D=120 - Bore 35 - B=40 (Art. SA120.40135) + Profiles 0÷12 |
| SX002.120.40150 | Complete with cutterhead in steel body D=120 - Bore 50 - B=40 (Art. SA120.40150) + Profiles 0÷12 |
| SXL002.100.45130 | Complete with cutterhead in light alloy body D=100 - Bore 30 - B=40÷50 (Art. SAL100.45130) + Profiles 0÷12 |
| SXL002.120.45135 | Complete with cutterhead in light alloy body D=120 - Bore 35 - B=40÷50 (Art. SAL120.45135) + Profiles 0÷12 |
| SXL002.120.45150 | Complete with cutterhead in light alloy body D=120 - Bore 50 - B=40÷50 (Art. SAL120.45150) + Profiles 0÷12 |

13 PROFILE CUTTERHEAD SETS WITH KNIVES AND CHIP LIMITERS (PROFILES 13÷24)

ART. SX003 - SXL003

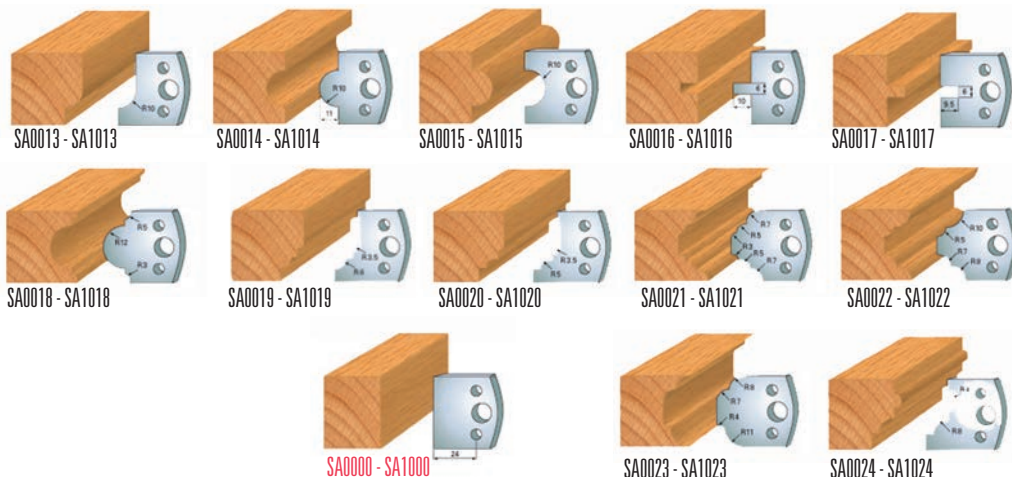

- Set in plastic box complete with cutterheads, **SP steel knives and chip limiters profile 0+13÷24**
- Cutterhead Z=2 tool body in steel (**Art. SX**)
- Cutterhead Z=2 tool body in light alloy (**Art. SXL**)
- For spindle moulders with manual feed (MAN)

| Item | Description |
|------------------|---|
| SX003.078.40030 | Complete with cutterhead in steel body D=78 - Bore 30 - B=40 (Art. SA078.40030) + Profiles and chip limiters 13÷24 |
| SX003.093.40030 | Complete with cutterhead in steel body D=93 - Bore 30 - B=40 (Art. SA093.40030) + Profiles and chip limiters 13÷24 |
| SX003.100.40030 | Complete with cutterhead in steel body D=100 - Bore 30 - B=40 (Art. SA100.40030) + Profiles and chip limiters 13÷24 |
| SX003.120.40035 | Complete with cutterhead in steel body D=120 - Bore 35 - B=40 (Art. SA120.40035) + Profiles and chip limiters 13÷24 |
| SX003.120.40050 | Complete with cutterhead in steel body D=120 - Bore 50 - B=40 (Art. SA120.40050) + Profiles and chip limiters 13÷24 |
| SXL003.100.45030 | Complete with cutterhead in light alloy body D=100 - Bore 30 - B=40÷50 (Art. SAL100.45030) + Profiles and chip limiters 13÷24 |
| SXL003.120.45035 | Complete with cutterhead in light alloy body D=120 - Bore 35 - B=40÷50 (Art. SAL120.45035) + Profiles and chip limiters 13÷24 |
| SXL003.120.45050 | Complete with cutterhead in light alloy body D=120 - Bore 50 - B=40÷50 (Art. SAL120.45050) + Profiles and chip limiters 13÷24 |

13 PROFILE CUTTERHEAD SETS WITH KNIVES (PROFILES 13÷24)

ART. SX003 - SXL003

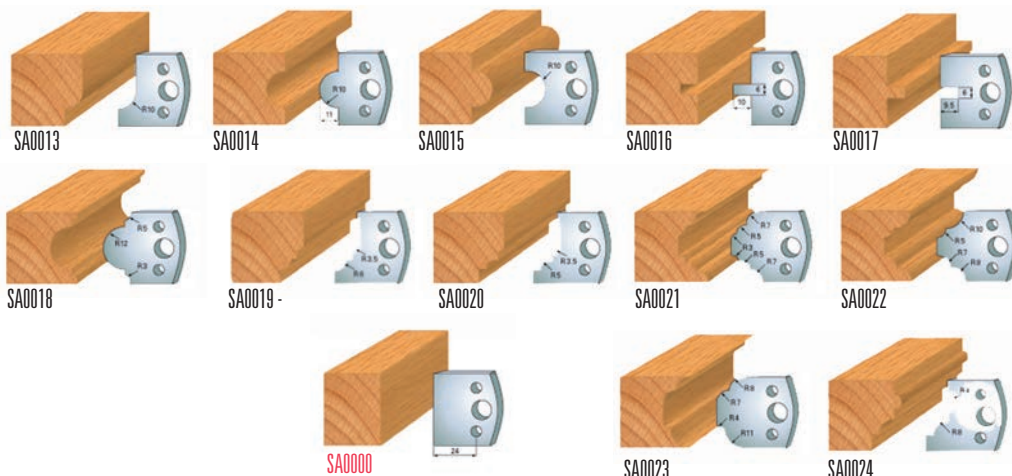

- Set in plastic box complete with cutterheads and SP steel knives 0+13÷24 (**without chip limiters**)
- Cutterhead Z=2 tool body in steel (**Art. SX**)
- Cutterhead Z=2 tool body in light alloy (**Art. SXL**)
- For spindle moulders with mechanical feed (MEC)

| Item | Description |
|------------------|---|
| SX003.078.40130 | Complete with cutterhead in steel body D=78 - Bore 30 - B=40 (Art. SA078.40130) + Profiles 13÷24 |
| SX003.093.40130 | Complete with cutterhead in steel body D=93 - Bore 30 - B=40 (Art. SA093.40130) + Profiles 13÷24 |
| SX003.100.40130 | Complete with cutterhead in steel body D=100 - Bore 30 - B=40 (Art. SA100.40130) + Profiles 13÷24 |
| SX003.120.40135 | Complete with cutterhead in steel body D=120 - Bore 35 - B=40 (Art. SA120.40135) + Profiles 13÷24 |
| SX003.120.40150 | Complete with cutterhead in steel body D=120 - Bore 50 - B=40 (Art. SA120.40150) + Profiles 13÷24 |
| SXL003.100.45130 | Complete with cutterhead in light alloy body D=100 - Bore 30 - B=40÷50 (Art. SAL100.45130) + Profiles 13÷24 |
| SXL003.120.45135 | Complete with cutterhead in light alloy body D=120 - Bore 35 - B=40÷50 (Art. SAL120.45135) + Profiles 13÷24 |
| SXL003.120.45150 | Complete with cutterhead in light alloy body D=120 - Bore 50 - B=40÷50 (Art. SAL120.45150) + Profiles 13÷24 |

13 PROFILE CUTTERHEAD SETS WITH KNIVES AND CHIP LIMITERS (PROFILES 25÷36)

ART. SX004 - SXL004

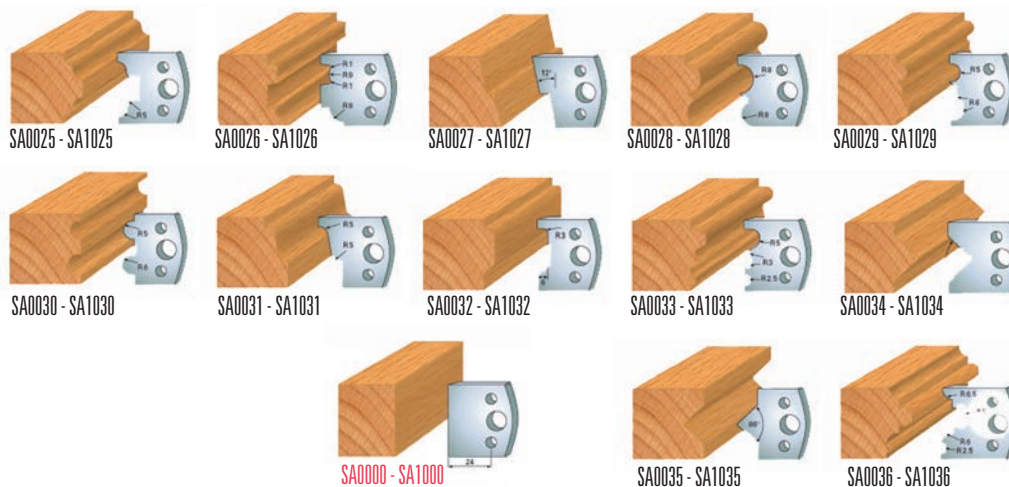

- Set in plastic box complete with cutterheads, **SP steel knives and chip limiters profile 0+25÷36**
- Cutterhead Z=2 tool body in steel (**Art. SX**)
- Cutterhead Z=2 tool body in light alloy (**Art. SXL**)
- For spindle moulders with manual feed (MAN)

| Item | Description |
|------------------|---|
| SX004.078.40030 | Complete with cutterhead in steel body D=78 - Bore 30 - B=40 (Art. SA078.40030) + Profiles and chip limiters 25÷36 |
| SX004.093.40030 | Complete with cutterhead in steel body D=93 - Bore 30 - B=40 (Art. SA093.40030) + Profiles and chip limiters 25÷36 |
| SX004.100.40030 | Complete with cutterhead in steel body D=100 - Bore 30 - B=40 (Art. SA100.40030) + Profiles and chip limiters 25÷36 |
| SX004.120.40035 | Complete with cutterhead in steel body D=120 - Bore 35 - B=40 (Art. SA120.40035) + Profiles and chip limiters 25÷36 |
| SX004.120.40050 | Complete with cutterhead in steel body D=120 - Bore 50 - B=40 (Art. SA120.40050) + Profiles and chip limiters 25÷36 |
| SXL004.100.45030 | Complete with cutterhead in light alloy body D=100 - Bore 30 - B=40÷50 (Art. SAL100.45030) + Profiles and chip limiters 25÷36 |
| SXL004.120.45035 | Complete with cutterhead in light alloy body D=120 - Bore 35 - B=40÷50 (Art. SAL120.45035) + Profiles and chip limiters 25÷36 |
| SXL004.120.45050 | Complete with cutterhead in light alloy body D=120 - Bore 50 - B=40÷50 (Art. SAL120.45050) + Profiles and chip limiters 25÷36 |

13 PROFILE CUTTERHEAD SETS WITH KNIVES (PROFILES 25÷36)

ART. SX004 - SXL004

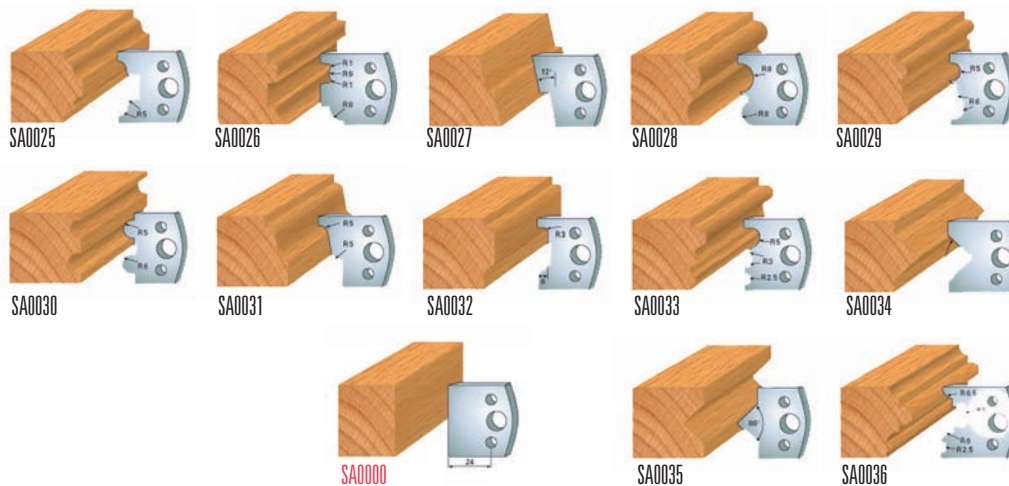

- Set in plastic box complete with cutterheads and SP steel knives 0+25÷36 (**without chip limiters**)
- Cutterhead Z=2 tool body in steel (**Art. SX**)
- Cutterhead Z=2 tool body in light alloy (**Art. SXL**)
- For spindle moulders with mechanical feed (MEC)

| Item | Description |
|------------------|---|
| SX004.078.40130 | Complete with cutterhead in steel body D=78 - Bore 30 - B=40 (Art. SA078.40130) + Profiles 25÷36 |
| SX004.093.40130 | Complete with cutterhead in steel body D=93 - Bore 30 - B=40 (Art. SA093.40130) + Profiles 25÷36 |
| SX004.100.40130 | Complete with cutterhead in steel body D=100 - Bore 30 - B=40 (Art. SA100.40130) + Profiles 25÷36 |
| SX004.120.40135 | Complete with cutterhead in steel body D=120 - Bore 35 - B=40 (Art. SA120.40135) + Profiles 25÷36 |
| SX004.120.40150 | Complete with cutterhead in steel body D=120 - Bore 50 - B=40 (Art. SA120.40150) + Profiles 25÷36 |
| SXL004.100.45130 | Complete with cutterhead in light alloy body D=100 - Bore 30 - B=40÷50 (Art. SAL100.45130) + Profiles 25÷36 |
| SXL004.120.45135 | Complete with cutterhead in light alloy body D=120 - Bore 35 - B=40÷50 (Art. SAL120.45135) + Profiles 25÷36 |
| SXL004.120.45150 | Complete with cutterhead in light alloy body D=120 - Bore 50 - B=40÷50 (Art. SAL120.45150) + Profiles 25÷36 |

**STANDARD PROFILE KNIVES IN "SP" STEEL - height 40x4 mm
(RELATING LIMITERS)**

**Example:
Knife SA0..
Limiter (SA1..)**

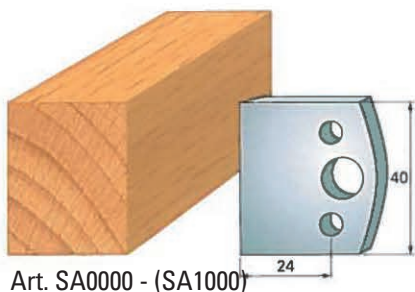

Art. SA0000 - (SA1000)

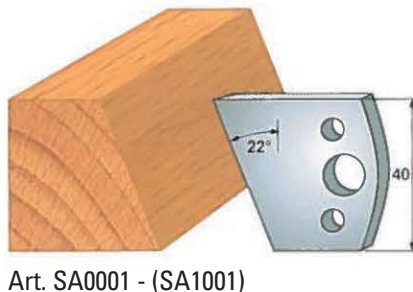

Art. SA0001 - (SA1001)

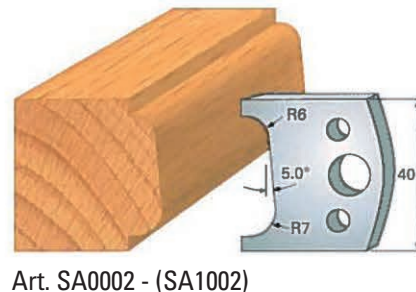

Art. SA0002 - (SA1002)

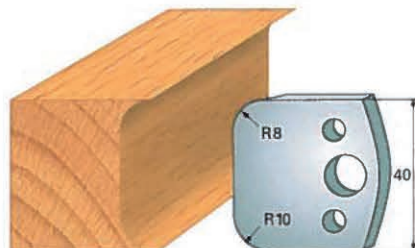

Art. SA0003 - (SA1003)

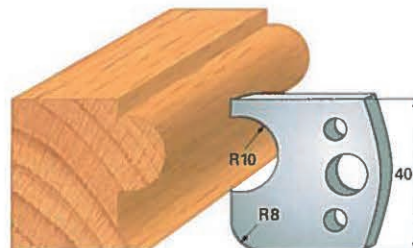

Art. SA0004 - (SA1004)

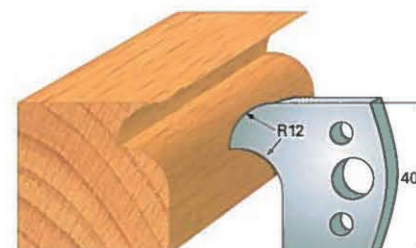

Art. SA0005 - (SA1005)

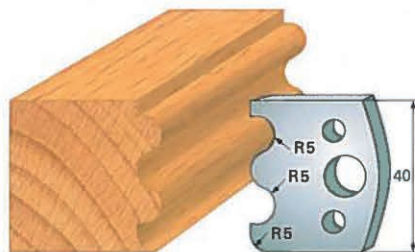

Art. SA0006 - (SA1006)

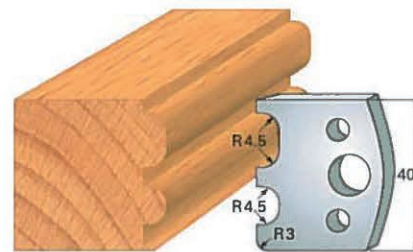

Art. SA0007 - (SA1007)

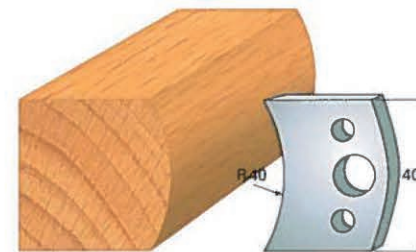

Art. SA0008 - (SA1008)

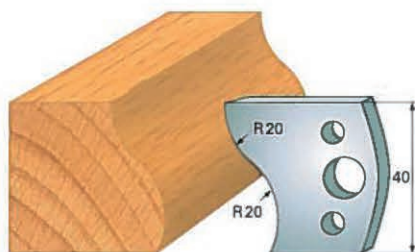

Art. SA0009 - (SA1009)

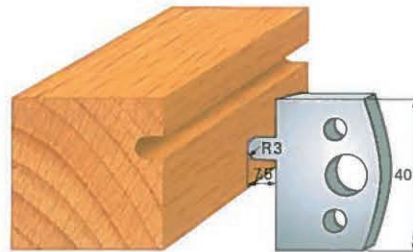

Art. SA0010 - (SA1010)

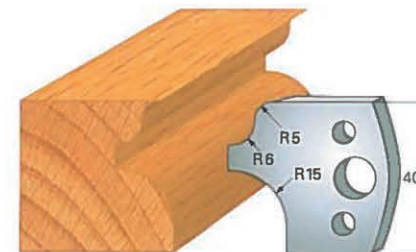

Art. SA0011 - (SA1011)

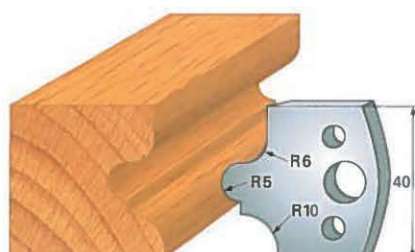

Art. SA0012 - (SA1012)

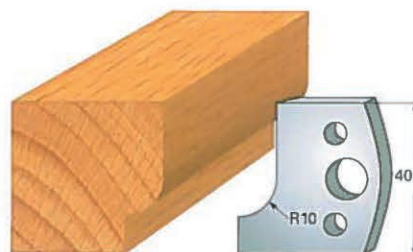

Art. SA0013 - (SA1013)

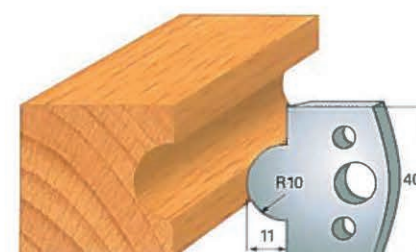

Art. SA0014 - (SA1014)

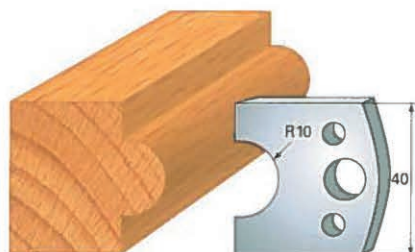

Art. SA0015 - (SA1015)

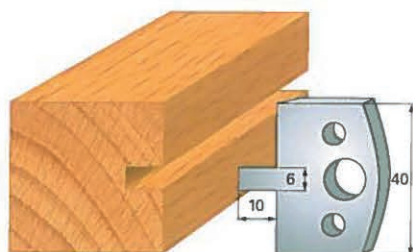

Art. SA0016 - (SA1016)

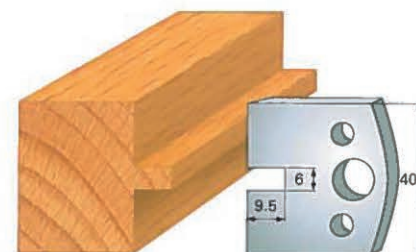

Art. SA0017 - (SA1017)

**STANDARD PROFILE KNIVES IN "SP" STEEL - height 40x4 mm
(RELATING LIMITERS)**

**Example:
Knife SA0..
Limiter (SA1..)**

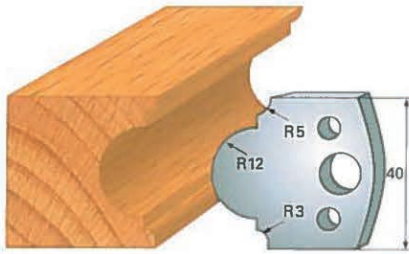

Art. SA0018 - (SA1018)

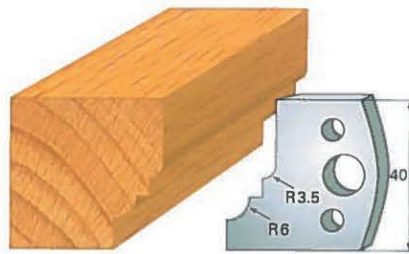

Art. SA0019 - (SA1019)

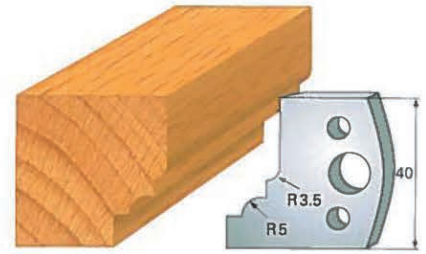

Art. SA0020 - (SA1020)

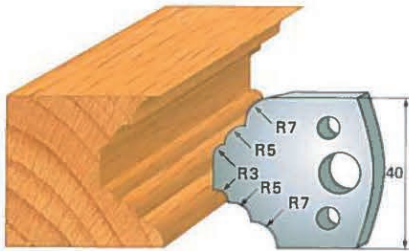

Art. SA0021 - (SA1021)

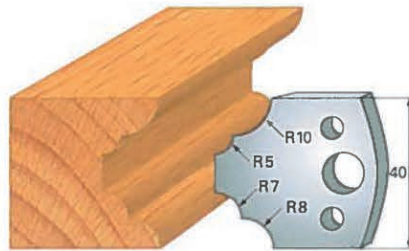

Art. SA0022 - (SA1022)

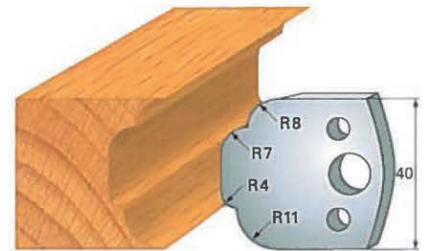

Art. SA0023 - (SA1023)

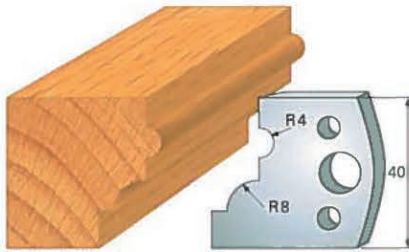

Art. SA0024 - (SA1024)

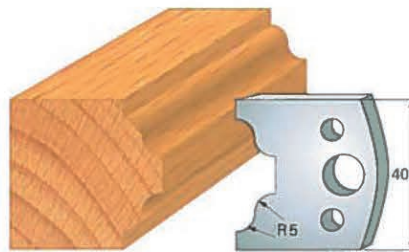

Art. SA0025 - (SA1025)

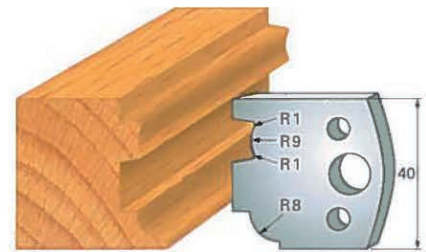

SA0026 - (SA1026)

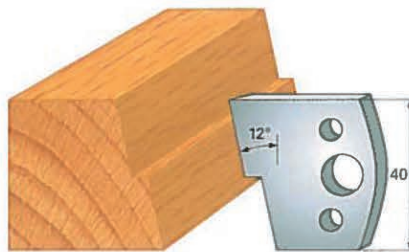

Art. SA0027 - (SA1027)



Art. SA0028 - (SA1028)

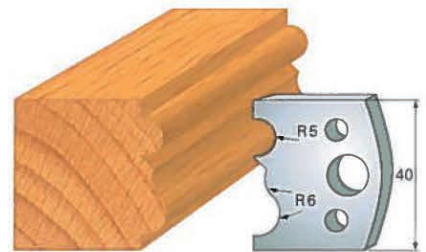

Art. SA0029 - (SA1029)

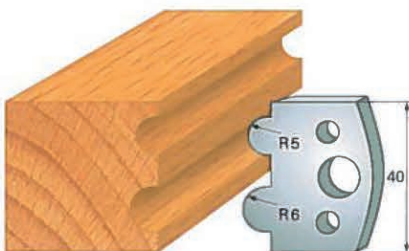

Art. SA0030 - (SA1030)

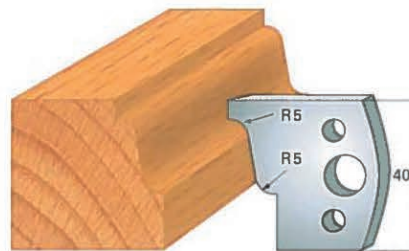

Art. SA0031 - (SA1031)

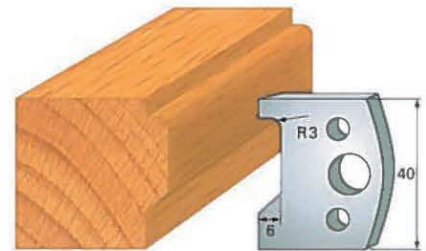

Art. SA0032 - (SA1032)

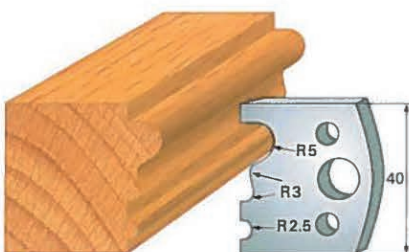

Art. SA0033 - (SA1033)

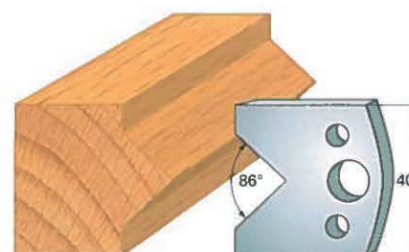

Art. SA0034 - (SA1034)

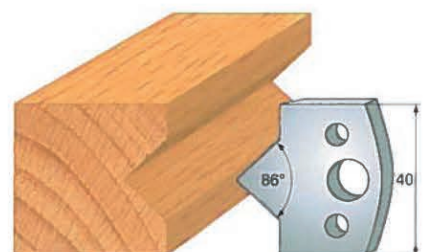

Art. SA0035 - (SA1035)

**STANDARD PROFILE KNIVES IN "SP" STEEL - height 40x4 mm
(RELATING LIMITERS)**

**Example:
Knife SA0..
Limiter (SA1..)**

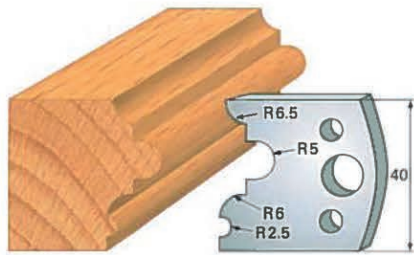

Art. SA0036 - (SA1036)

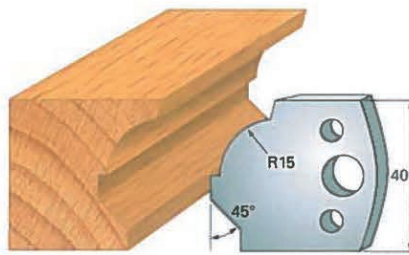

Art. SA0037 - (SA1037)

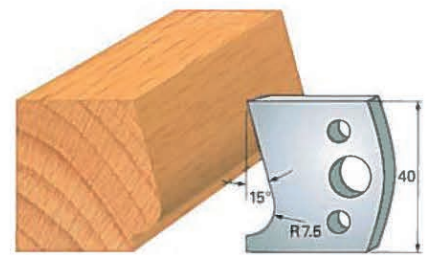

Art. SA0038 - (SA1038)

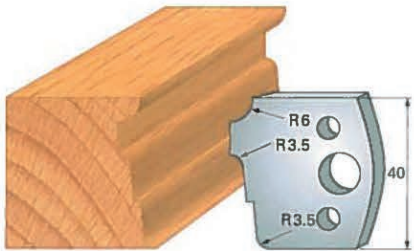

Art. SA0039 - (SA1039)

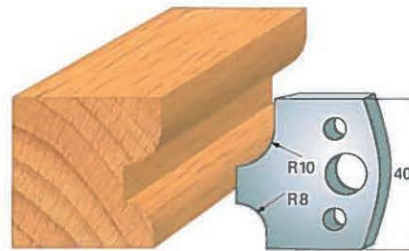

Art. SA0040 - (SA1040)

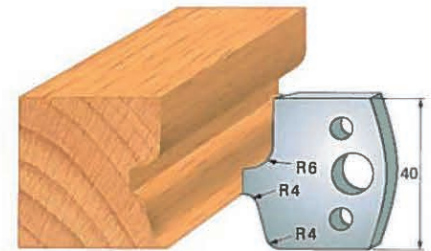

Art. SA0041 - (SA1041)

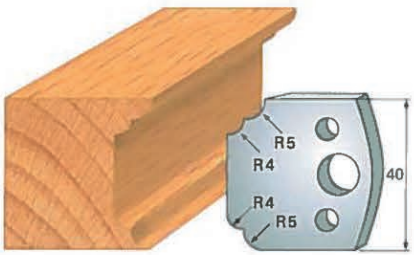

Art. SA0042 - (SA1042)

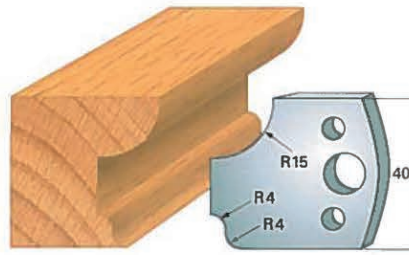

Art. SA0043 - (SA1043)

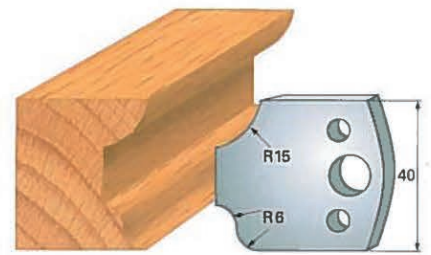

Art. SA0044 - (SA1044)

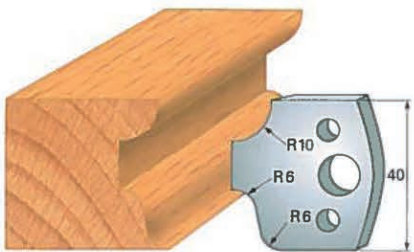

Art. SA0045 - (SA1045)

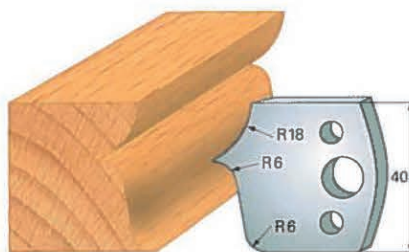

Art. SA0046 - (SA1046)

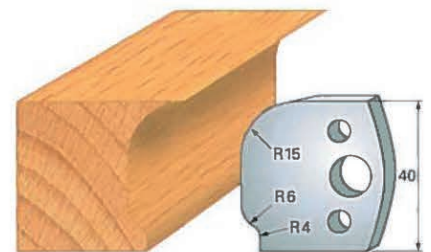

Art. SA0047 - (SA1047)

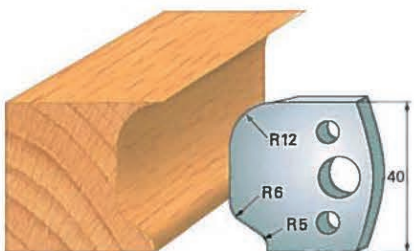

Art. SA0048 - (SA1048)

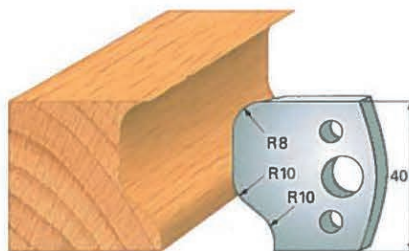

Art. SA0049 - (SA1049)

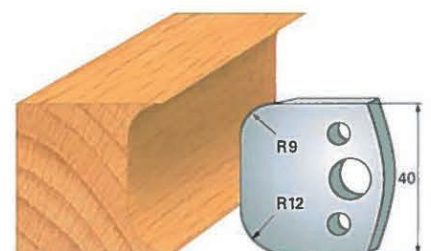

Art. SA0050 - (SA1050)



Art. SA0051 - (SA1051)

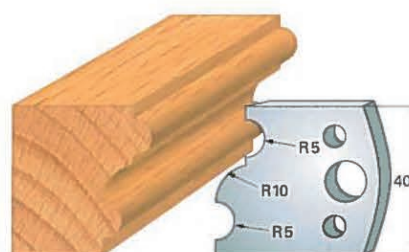

Art. SA0052 - (SA1052)

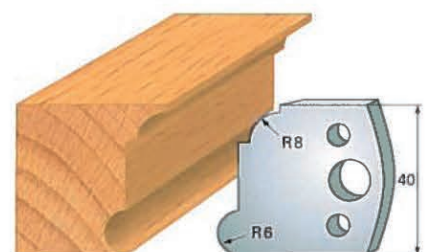

Art. SA0053 - (SA1053)

**STANDARD PROFILE KNIVES IN "SP" STEEL - height 40x4 mm
(RELATING LIMITERS)**

**Example:
Knife SA0..
Limiter (SA1..)**

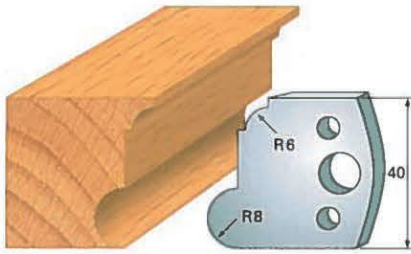

Art. SA0054 - (SA1054)

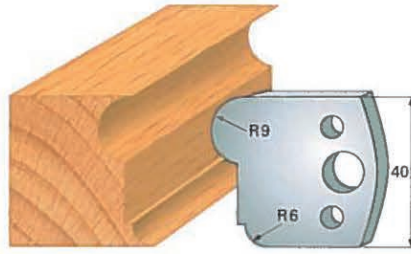

Art. SA0055 - (SA1055)

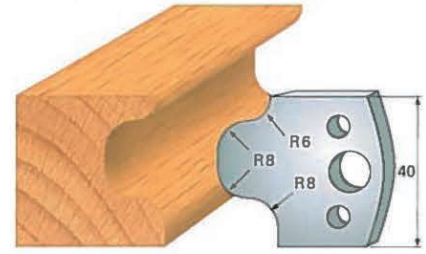

Art. SA0056 - (SA1056)

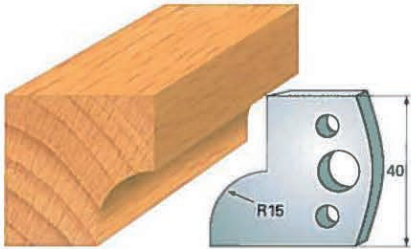

Art. SA0057 - (SA1057)

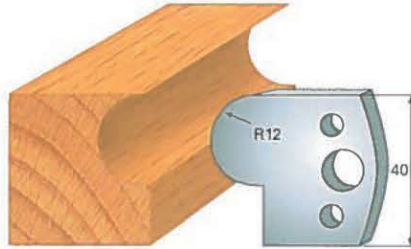

Art. SA0058 - (SA1058)

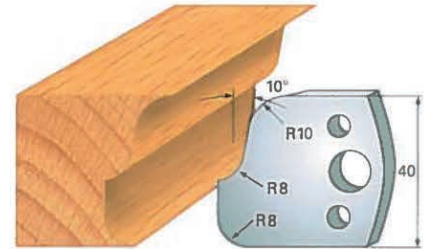

Art. SA0059 - (SA1059)

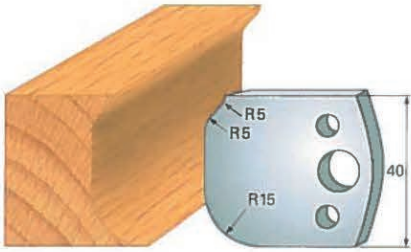

Art. SA0060 - (SA1060)

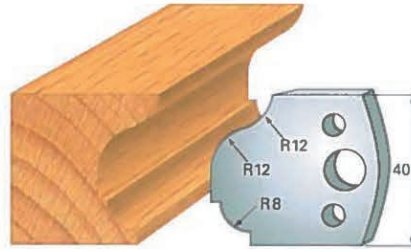

Art. SA0061 - (SA1061)

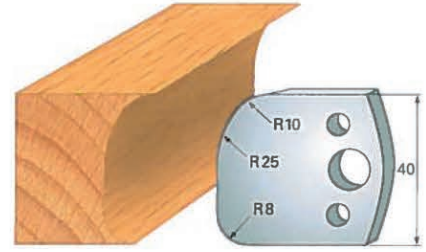

Art. SA0062 - (SA1062)

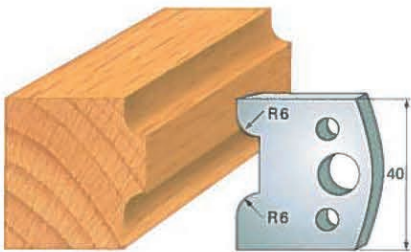

Art. SA0063 - (SA1063)

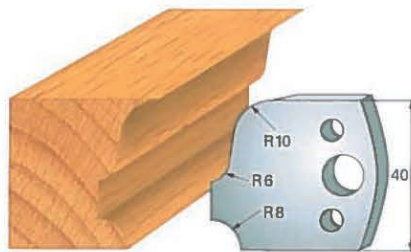

Art. SA0064 - (SA1064)

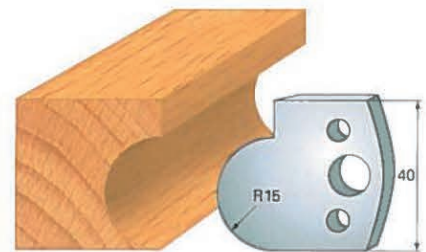

Art. SA0065 - (SA1065)

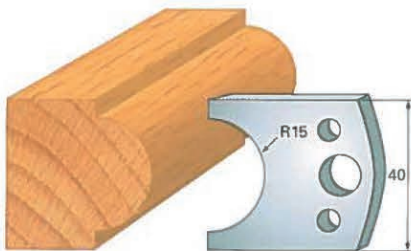

Art. SA0066 - (SA1066)

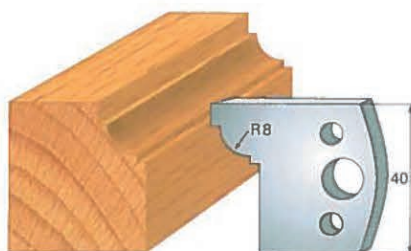

Art. SA0067 - (SA1067)

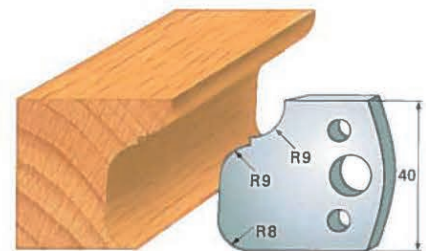

Art. SA0068 - (SA1068)

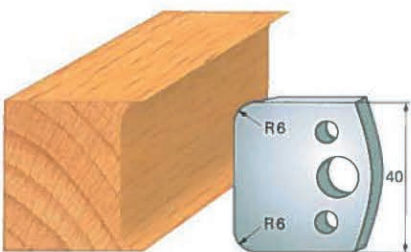

Art. SA0069 - (SA1069)

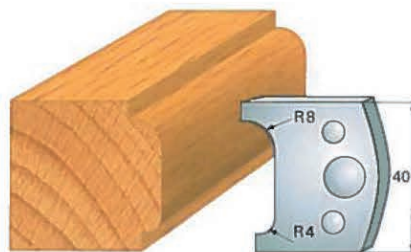

Art. SA0070 - (SA1070)

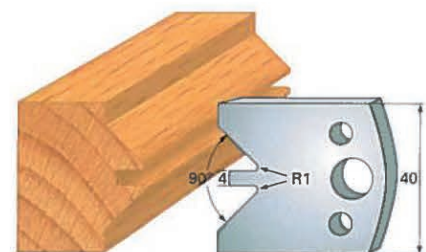

Art. SA0071 - (SA1071)

**STANDARD PROFILE KNIVES IN "SP" STEEL - height 40x4 mm
(RELATING LIMITERS)**

**Example:
Knife SA0..
Limiter (SA1..)**

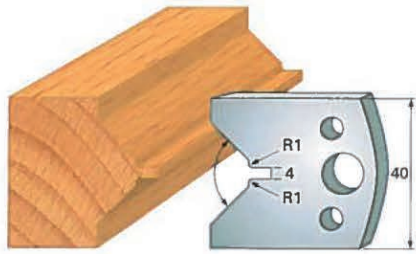

Art. SA0072 - (SA1072)

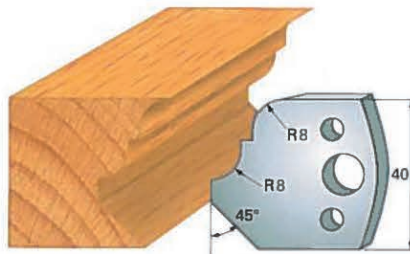

Art. SA0073 - (SA1073)

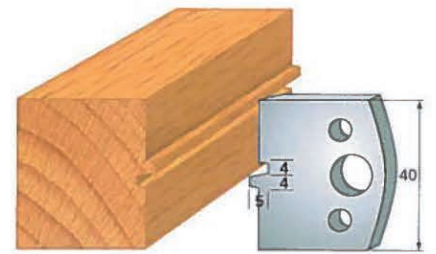

Art. SA0074 - (SA1074)

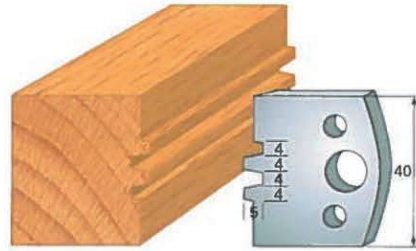

Art. SA0075 - (SA1075)

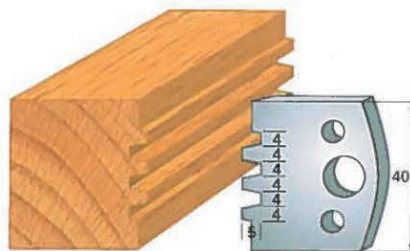

Art. SA0076 - (SA1076)

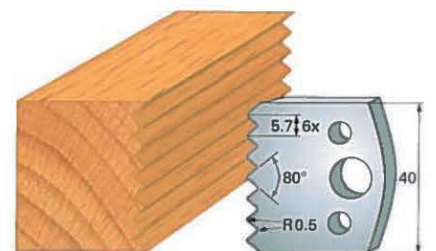

Art. SA0077 - (SA1077)

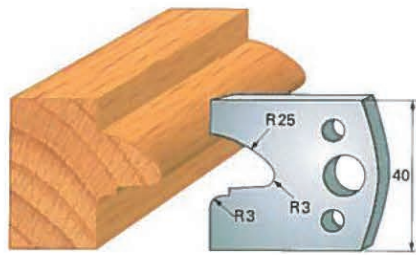

Art. SA0078 - (SA1078)

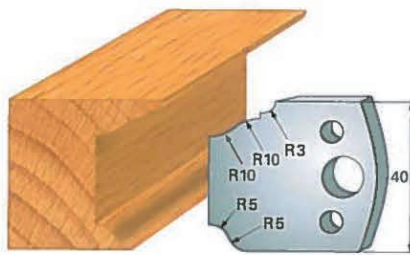

Art. SA0079 - (SA1079)

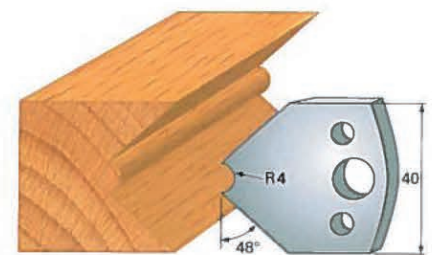

Art. SA0080 - (SA1080)

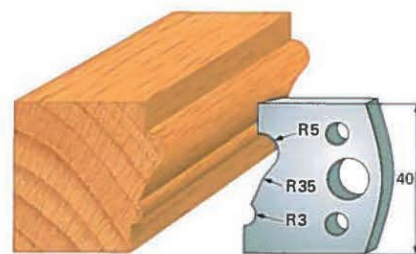

Art. SA0081 - (SA1081)

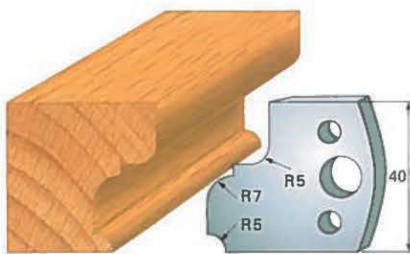

Art. SA0082 - (SA1082)

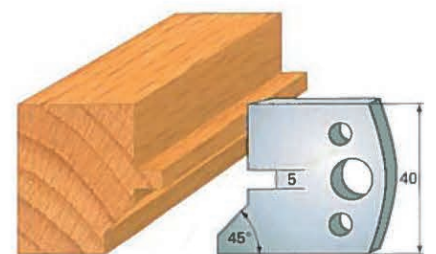

Art. SA0083 - (SA1083)

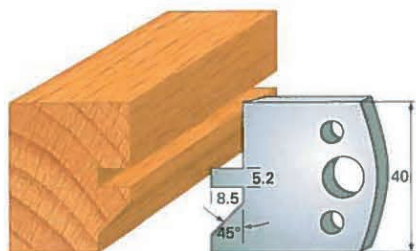

Art. SA0084 - (SA1084)

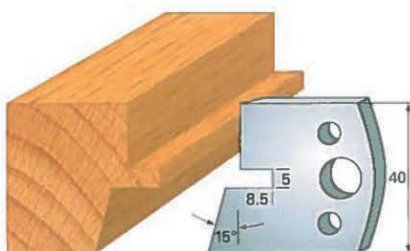

Art. SA0085 - (SA1085)

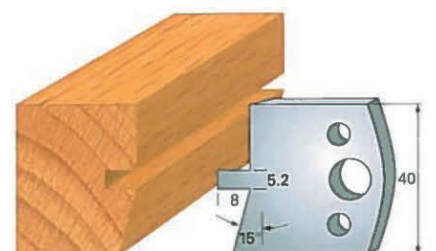

Art. SA0086 - (SA1086)

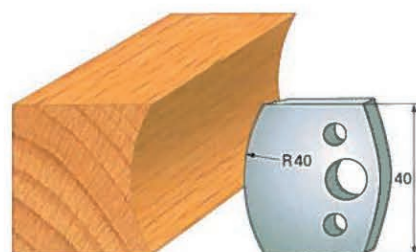

Art. SA0087 - (SA1087)

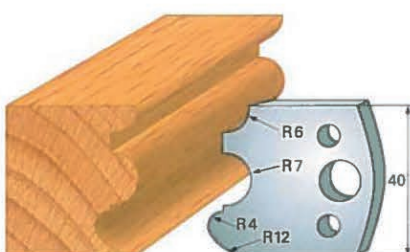

Art. SA0088 - (SA1088)

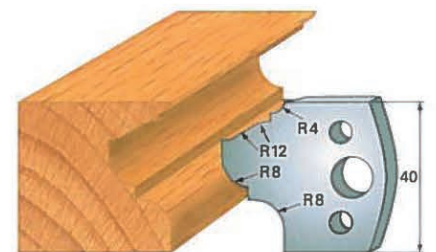

Art. SA0089 - (SA1089)

**STANDARD PROFILE KNIVES IN "SP" STEEL - height 40x4 mm
(RELATING LIMITERS)**

**Example:
Knife SA0..
Limiter (SA1..)**

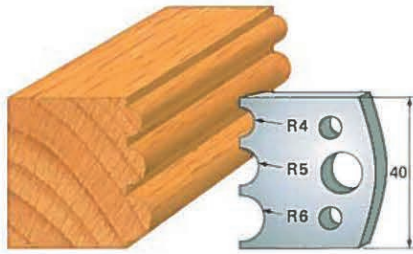

Art. SA0090 - (SA1090)

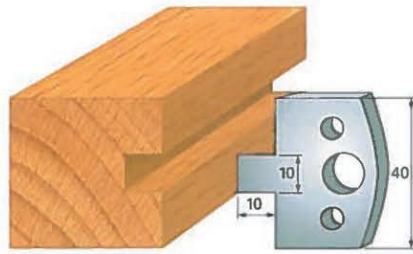

Art. SA0091 - (SA1091)

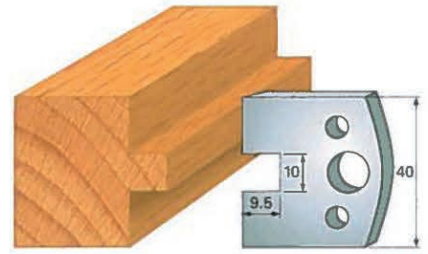

Art. SA0092 - (SA1092)

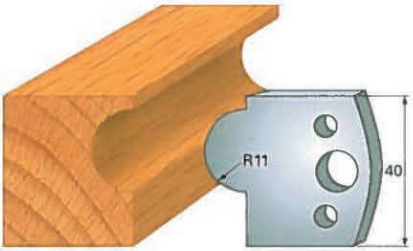

Art. SA0093 - (SA1093)

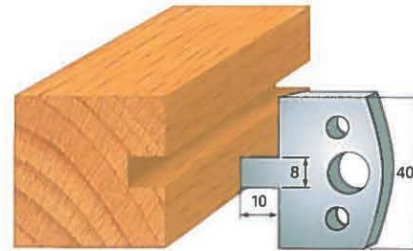

Art. SA0094 - (SA1094)

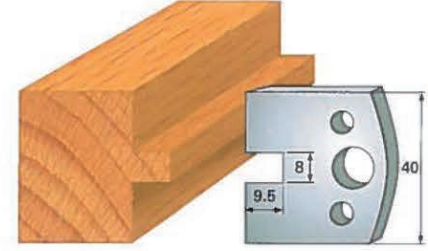

Art. SA0095 - (SA1095)

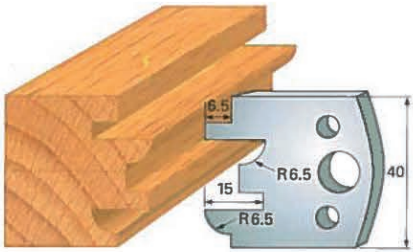

Art. SA0096 - (SA1096)

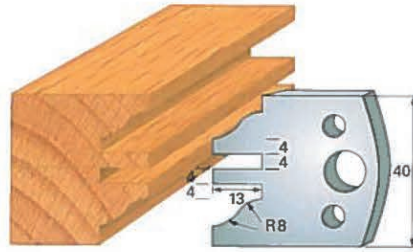

Art. SA0097 - (SA1097)

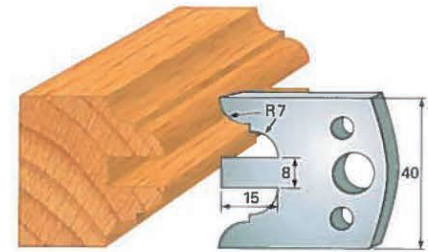

Art. SA0098 - (SA1098)

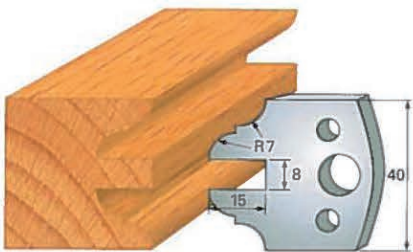

Art. SA0099 - (SA1099)

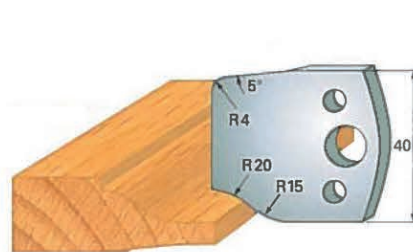

Art. SA0100 - (SA1100)

**STANDARD PROFILE KNIVES IN "SP" STEEL - height 50x4 mm
(RELATING LIMITERS)**

**Example:
Knife SA2..
Limiter (SA3..)**

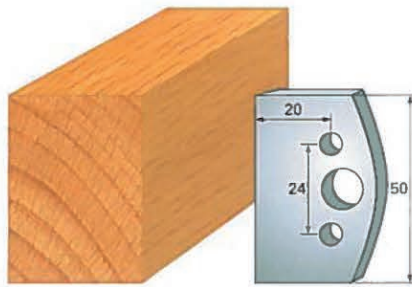

Art. SA2000 - (SA3000)

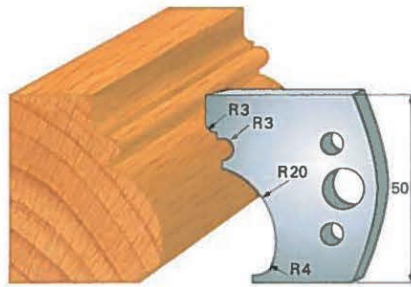

Art. SA2001 - (SA3001)

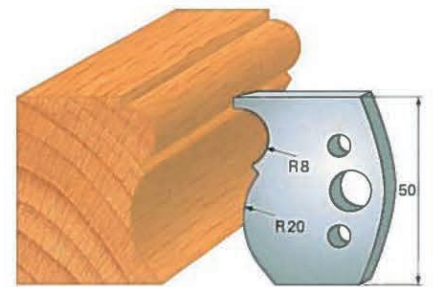

Art. SA2002 - (SA3002)

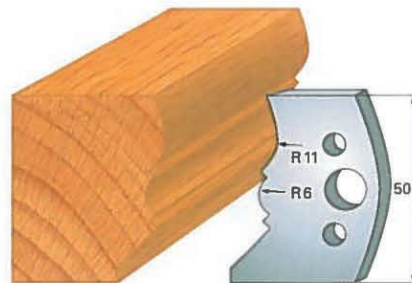

Art. SA2004 - (SA3004)

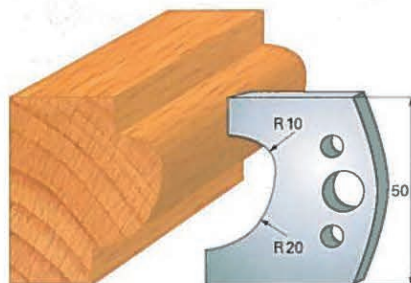

Art. SA2005 - (SA3005)

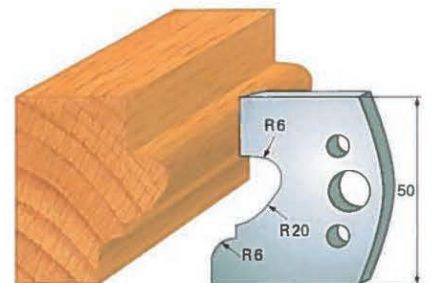

Art. SA2006 - (SA3006)

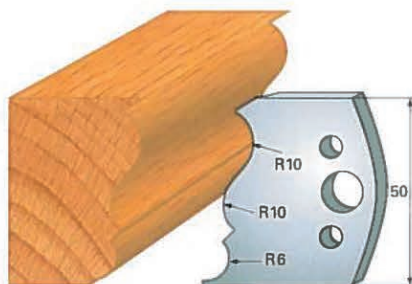

Art. SA2007 - (SA3007)

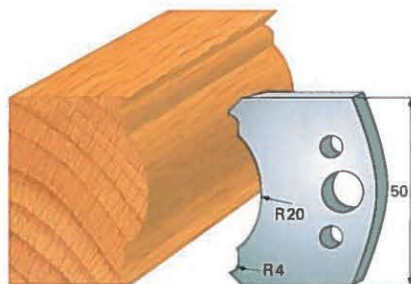

Art. SA2008 - (SA3008)

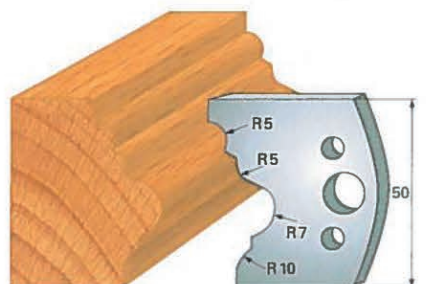

Art. SA2009 - (SA3009)

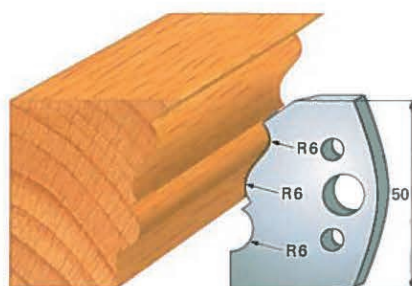

Art. SA2010 - (SA3010)

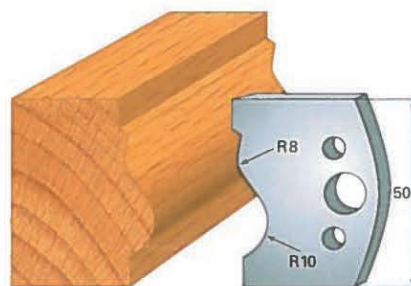

Art. SA2011 - (SA3011)

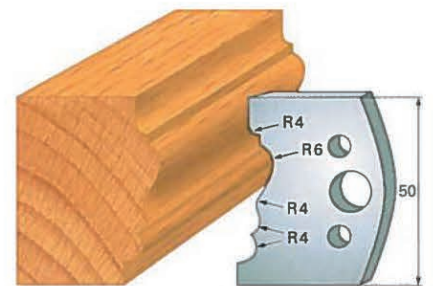

Art. SA2012 - (SA3012)

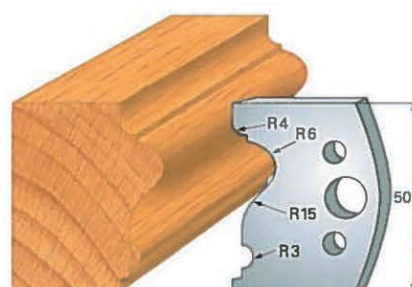

Art. SA2013 - (SA3013)

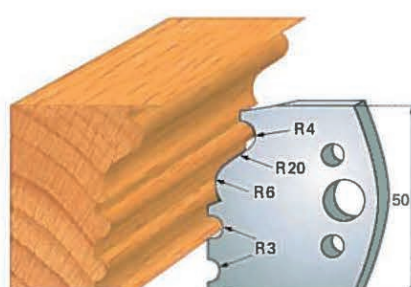

Art. SA2019 - (SA3014)

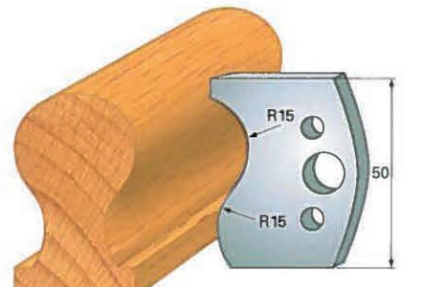

Art. SA2015 - (SA3015)

**STANDARD PROFILE KNIVES IN "SP" STEEL - height 50x4 mm
(RELATING LIMITERS)**

**Example:
Knife SA2..
Limiter (SA3..)**

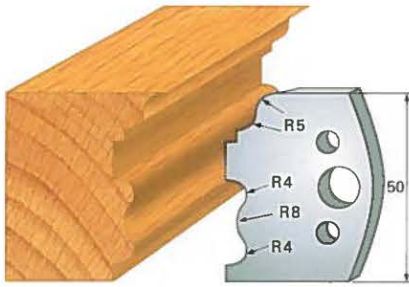

Art. SA2016 - (SA3016)

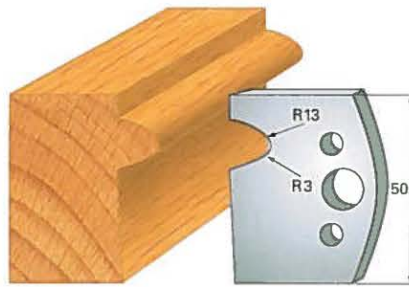

Art. SA2017 - (SA3017)

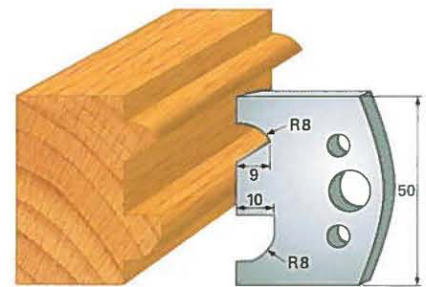

Art. SA2018 - (SA3018)

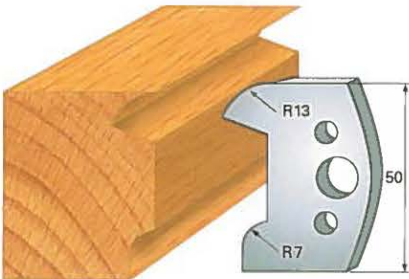

Art. SA2019 - (SA3019)

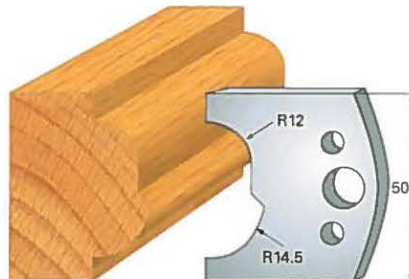

Art. SA2020 - (SA3020)

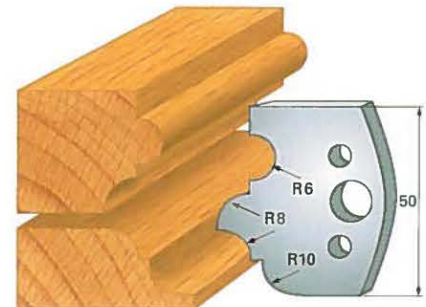

Art. SA2021 - (SA3021)

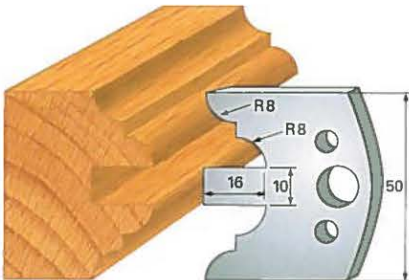

Art. SA2022 - (SA3022)

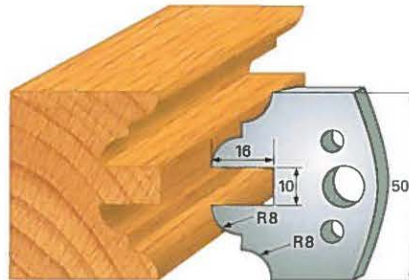

Art. SA2023 - (SA3023)

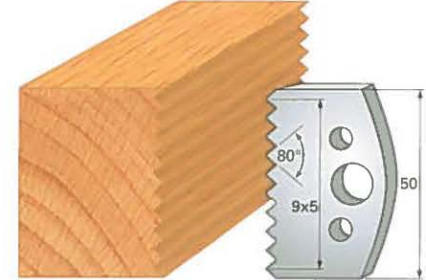

Art. SA2024 - (SA3024)

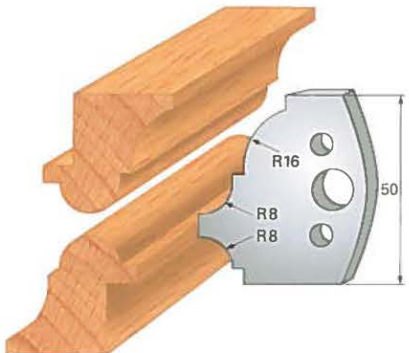

Art. SA2025 - (SA3025)

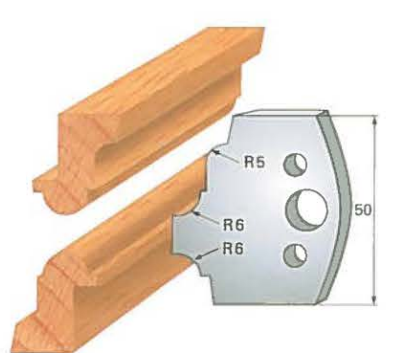

Art. SA2026 - (SA3026)

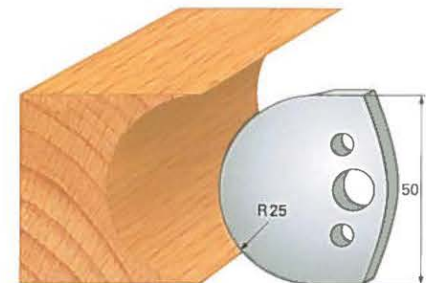

Art. SA2027 - (SA3027)



Art. SA2028 - (SA3028)



Art. SA2029 - (SA3029)

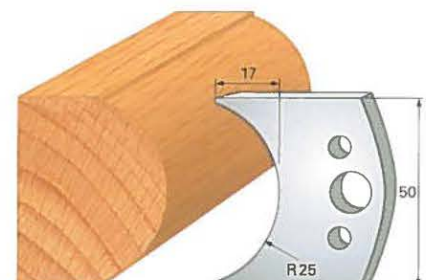

Art. SA2030 - (SA3030)

**STANDARD PROFILE KNIVES IN "SP" STEEL - height 50x4 mm
(RELATING LIMITERS)**

**Example:
Knife SA2.
Limiter (SA3..)**



Art. SA2031 - (SA3031)



Art. SA2032 - (SA3032)

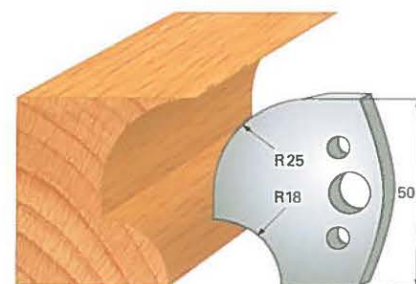

Art. SA2033 - (SA3033)

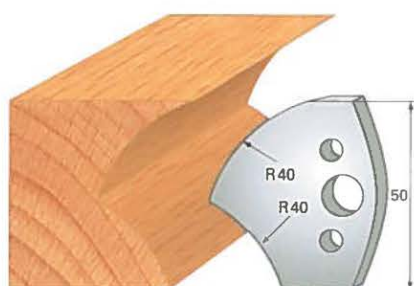

Art. SA2034 - (SA3034)

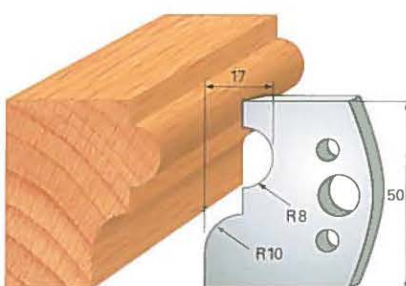

Art. SA2035 - (SA3035)

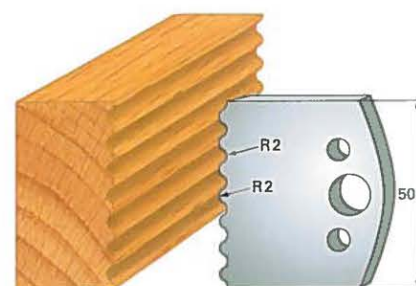

Art. SA2036 - (SA3036)

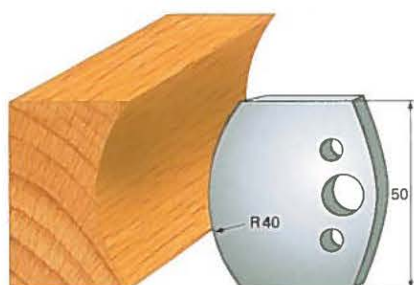

Art. SA2037 - (SA3037)

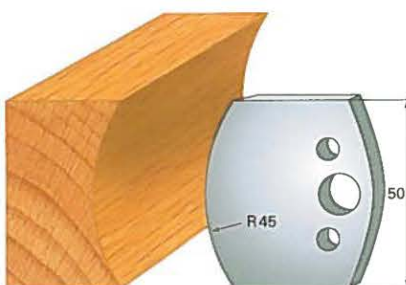

Art. SA2038 - (SA3038)

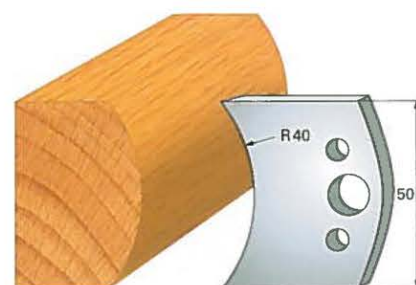

Art. SA2039 - (SA3039)

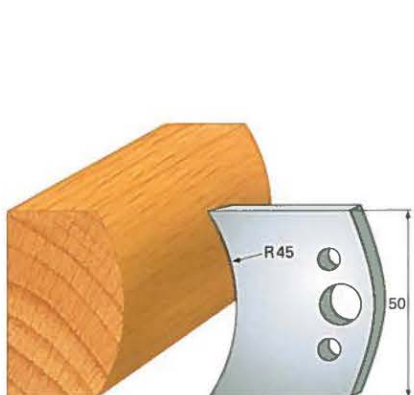

Art. SA2040 - (SA3040)

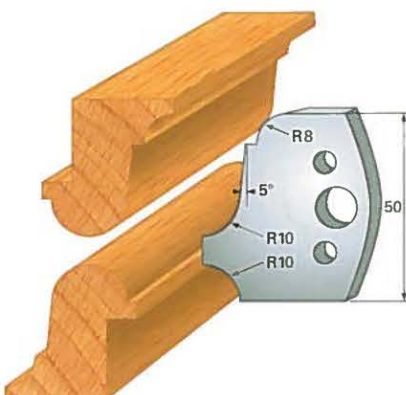

Art. SA2041 - (SA3041)

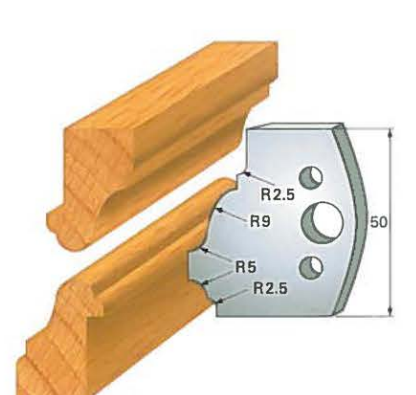

Art. SA2042 - (SA3042)

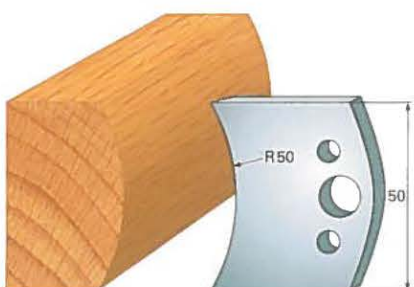

Art. SA2043 - (SA3043)



Art. SA2044 - (SA3044)

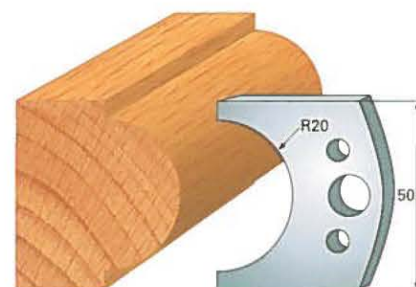

Art. SA2045 - (SA3045)

**STANDARD PROFILE KNIVES IN "SP" STEEL - height 50x4 mm
(RELATING LIMITERS)**

**Example:
Knife SA2..
Limiter (SA3..)**

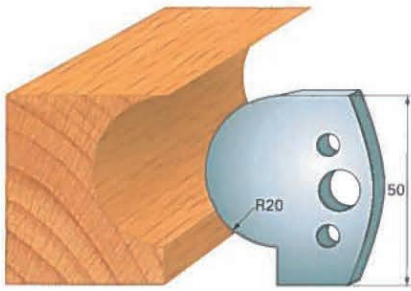

Art. SA2046 - (SA3046)

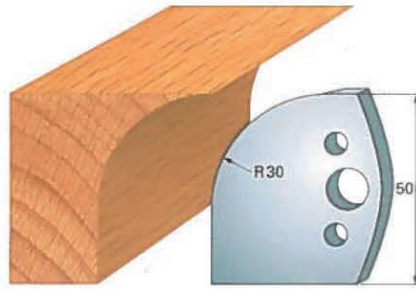

Art. SA2047 - (SA3047)

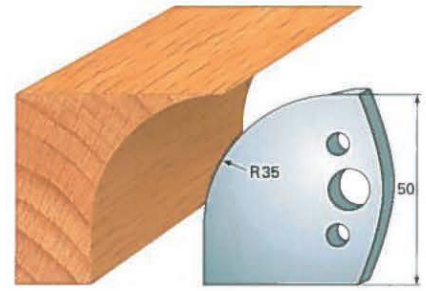

Art. SA2048 - (SA3048)

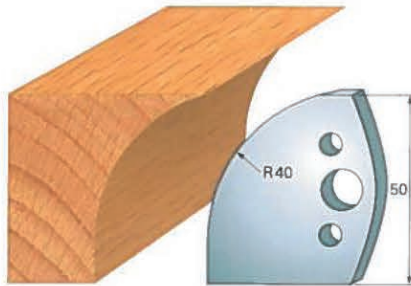

Art. SA2049 - (SA3049)

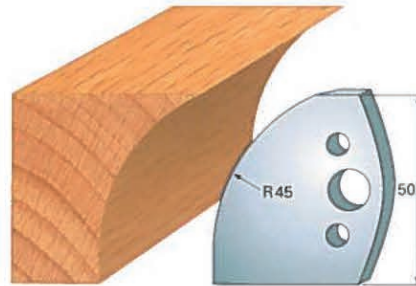

Art. SA2050 - (SA3050)

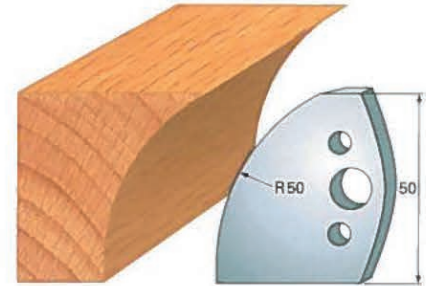

Art. SA2051 - (SA3051)

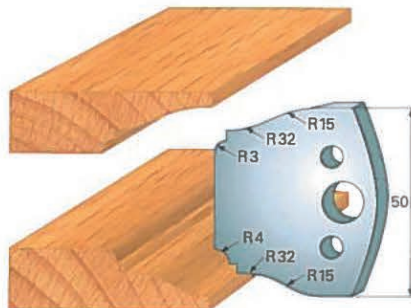

Art. SA2052 - (SA3052)

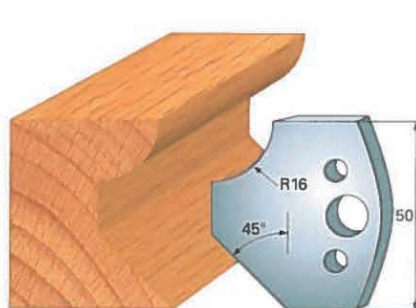

Art. SA2053 - (SA3053)

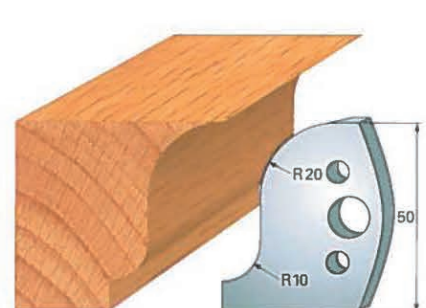

Art. SA2054 - (SA3054)

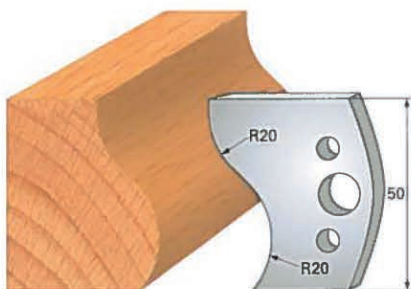

Art. SA2055 - (SA3055)

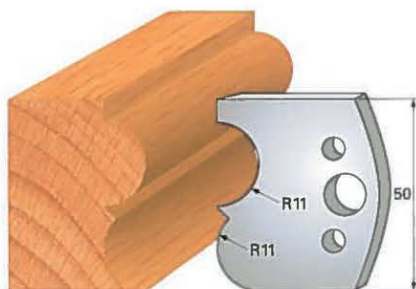

Art. SA2056 - (SA3056)



Art. SA2057 - (SA3057)

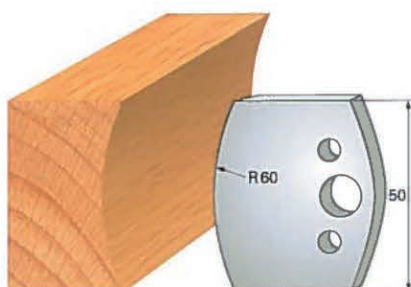

Art. SA2058 - (SA3058)

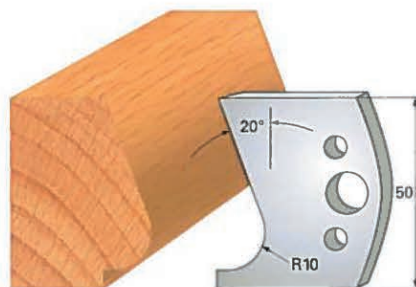

Art. SA2059 - (SA3059)

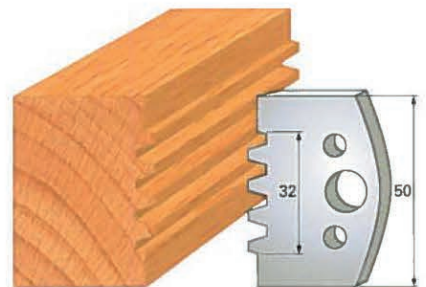

Art. SA2060 - (SA3060)

**STANDARD PROFILE KNIVES IN "SP" STEEL - height 50x4 mm
(RELATING LIMITERS)**

**Example:
Knife SA2..
Limiter (SA3..)**

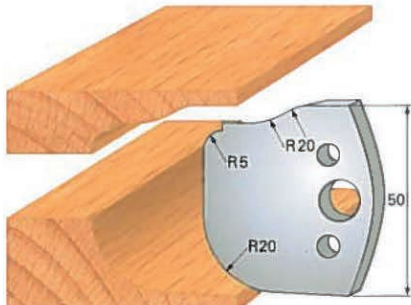

Art. SA2061 - (SA3061)

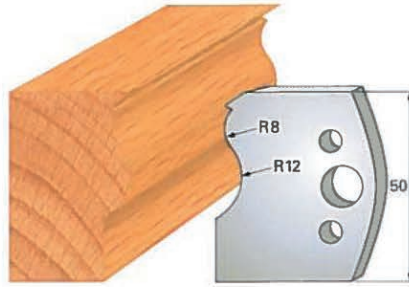

Art. SA2062 - (SA3062)

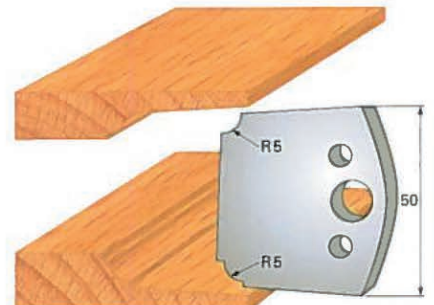

Art. SA2063 - (SA3063)

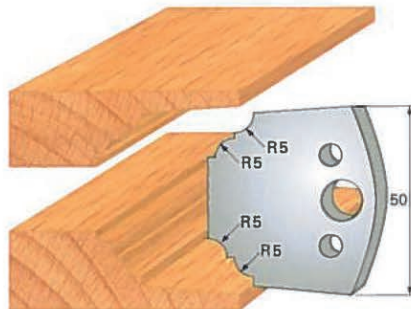

Art. SA2064 - (SA3064)

HW ADJUSTABLE CUTTERHEAD WITH REVERSIBLE KNIVES FOR GROOVES

ART. TA

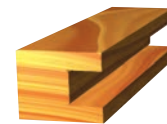
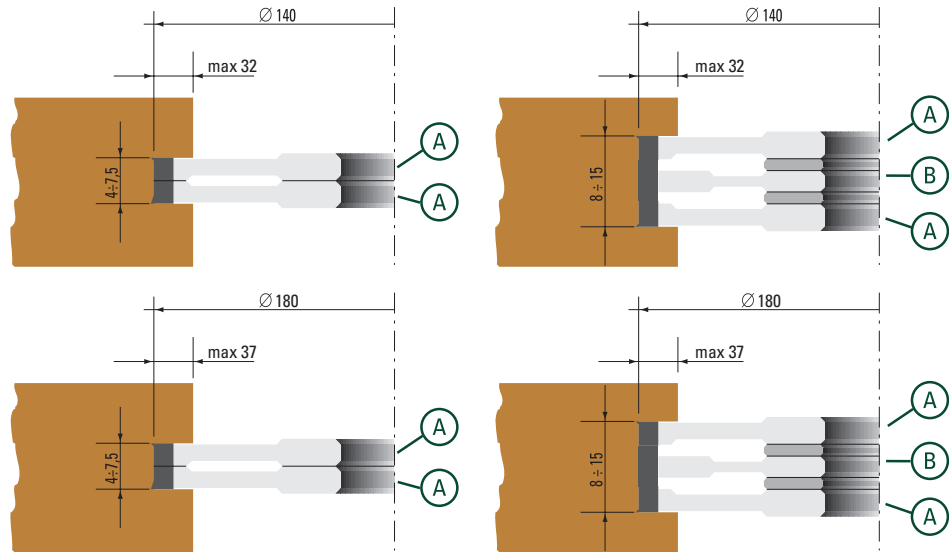

- For precision grooves 4 to 15 mm
- Adjustable by using spacer rings (included)
- Cutterhead in steel with reversible HW knives
- Manual feed (MAN)

| Item | | D | d | B | Z | V | E _{max} |
|-------------|-------|-----|----|-------|-----|---|------------------|
| TA140.07530 | A+A | 140 | 30 | 4±7,5 | 4 | 4 | 32 |
| TA140.07535 | A+A | 140 | 35 | 4±7,5 | 4 | 4 | 32 |
| TA140.07630 | B | 140 | 30 | 7,65 | 2 | - | 32 |
| TA140.07635 | B | 140 | 35 | 7,65 | 2 | - | 32 |
| TA140.15030 | A+B+A | 140 | 30 | 4±15 | 4+2 | 4 | 32 |
| TA140.15035 | A+B+A | 140 | 35 | 4±15 | 4+2 | 4 | 32 |
| TA180.07530 | A+A | 180 | 30 | 4±7,5 | 8 | 4 | 37 |
| TA180.07535 | A+A | 180 | 35 | 4±7,5 | 8 | 4 | 37 |
| TA180.07630 | B | 180 | 30 | 7,65 | 2 | - | 37 |
| TA180.07635 | B | 180 | 35 | 7,65 | 2 | - | 37 |
| TA180.15030 | A+B+A | 180 | 30 | 4±15 | 8 | 4 | 37 |
| TA180.15035 | A+B+A | 180 | 35 | 4±15 | 8 | 4 | 37 |

| Spare parts: | TA140.075 | | TA140.076 | |
|---------------|------------|------------|------------|------------|
| | Dimensions | Item | Dimensions | Item |
| Knife | 18x18x1,95 | Z055.020.N | 7,6x12x1,5 | Z055.000.N |
| Knife screw | M4x3,2 | Z051.700.R | | |
| Threaded ring | 12x1,7 | Z060.701.R | | |
| Spur | 14x14x1,2 | Z055.006.N | | |
| Spur screw | M4x3,2 | Z051.700.R | | |
| Threaded ring | 10x1,65 | Z060.700.R | | |
| Wedge | - | - | L=6,8 | Z056.700.N |
| Wedge screw | - | - | M5x18 | Z051.800.R |

HW CUTTERHEADS WITH REVERSIBLE KNIVES FOR "LAMELLO®"

ART. TAH

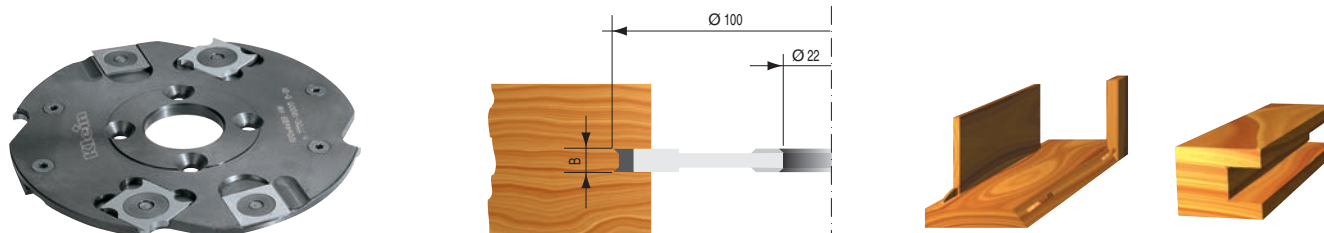

- For "Lamello®" biscuit jointers on any kind of wood
- Cutterhead in steel with reversible HW knives and spurs
- Manual feed (MAN)

| Item | D | d | B | Z | V |
|--------------|-----|----|---|---|---|
| TAH100.20622 | 100 | 22 | 4 | 4 | 4 |

Spare parts:

| | Dimensions | Item |
|---------------|------------|------------|
| Knife | 18x18x1,95 | Z055.020.N |
| Knife screw | M4x3,2 | Z051.700.R |
| Threaded ring | 12x1,7 | Z060.701.R |
| Spur | 14x14x1,2 | Z055.006.N |
| Spur screw | M4x3,2 | Z051.700.R |
| Threaded ring | 10x1,65 | Z060.700.R |

HW ADJUSTABLE CUTTERHEAD WITH REVERSIBLE KNIVES FOR GROOVES

ART. TB

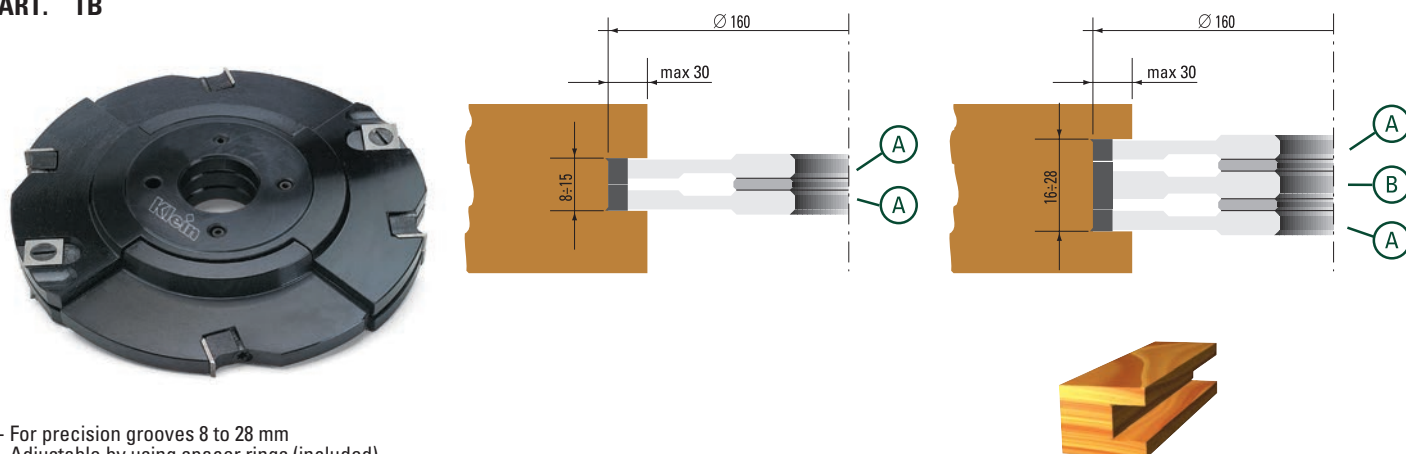

- For precision grooves 8 to 28 mm
- Adjustable by using spacer rings (included)
- Cutterhead in steel with reversible HW knives
- Manual feed (MAN)

| Item | | D | d | B | Z | V | E _{max} |
|-------------|-------|-----|----|------|-----|---|------------------|
| TB160.15030 | A+A | 160 | 30 | 8±15 | 4 | 4 | 30 |
| TB160.15035 | A+A | 160 | 35 | 8±15 | 4 | 4 | 30 |
| TB160.15040 | A+A | 160 | 40 | 8±15 | 4 | 4 | 30 |
| TB160.15130 | B | 160 | 30 | 15 | 2 | - | 30 |
| TB160.15135 | B | 160 | 35 | 15 | 2 | - | 30 |
| TB160.15140 | B | 160 | 40 | 15 | 2 | - | 30 |
| TB160.28030 | A+B+A | 160 | 30 | 8±28 | 4+2 | 4 | 30 |
| TB160.28035 | A+B+A | 160 | 35 | 8±28 | 4+2 | 4 | 30 |
| TB160.28040 | A+B+A | 160 | 40 | 8±28 | 4+2 | 4 | 30 |

| Spare parts: | TB160.150 | | TB160.151 | |
|--------------|-------------|------------|------------|------------|
| | Dimensions | Item | Dimensions | Item |
| Knife | 7,65x12x1,5 | Z055.000.N | 15x12x1,5 | Z055.002.N |
| Wedge | L=6,8 | Z056.700.N | L=14 | Z056.701.N |
| Wedge screw | M5x18 | Z051.800.R | M7x21 | Z051.801.R |
| Spur | 14x14x2 | Z055.007.N | | |
| Spur screw | M5x7 | Z051.701.R | | |

HW ADJUSTABLE GROOVING CUTTERHEAD FOR TENONS

ART. TC

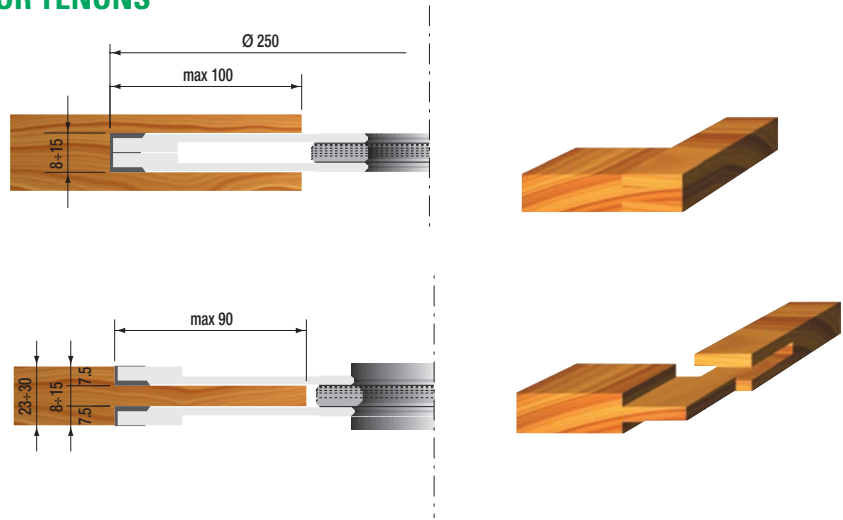

- For precision tenons 8 to 15 mm
- Adjustable by using spacer rings (included)
- Cutterhead in steel with reversible HW knives and spurs
- Manual feed (MAN)

| Item | D | d | B | Z | V | E _{max} |
|-------------|-----|----|------|---|---|------------------|
| TC250.15030 | 250 | 30 | 8÷15 | 4 | 4 | 100 |

Spare parts:

| | Dimensions | Item |
|-------------|------------|------------|
| Knife | 7,6x12x1,5 | Z055.000.N |
| Wedge | L=6,8 | Z056.700.N |
| Wedge screw | M5x18 | Z051.800.R |
| Spur | 14x14x2 | Z055.007.N |
| Spur screw | M5x7 | Z051.701.R |

HW CUTTERHEAD WITH REVERSIBLE STRAIGHT KNIVES AND SPURS

ART. TEL

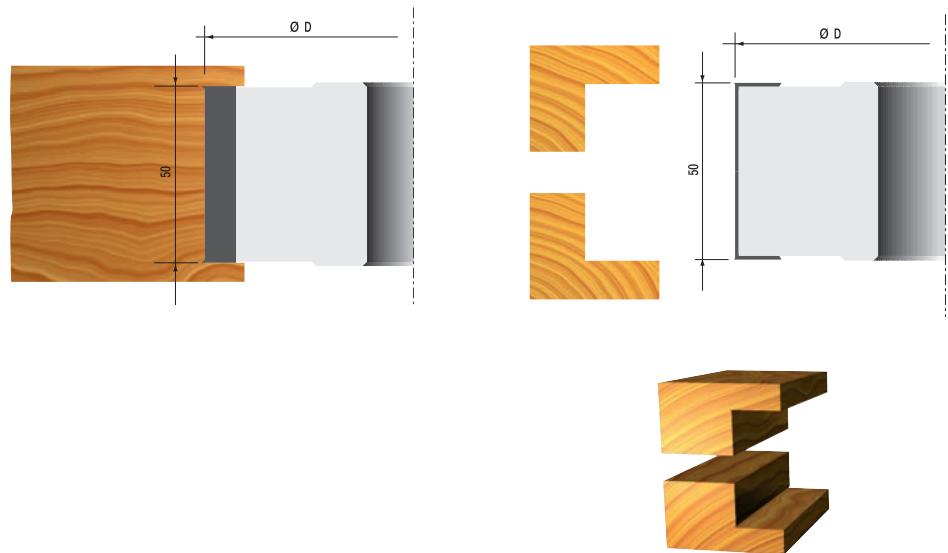

- Cutterhead for precision rebating straight cut
- Light alloy with reversible HW knives and spurs
- Manual feed (MAN)

| Item | D | d | B | Z | V |
|--------------|-----|----|----|---|---|
| TEL100.50030 | 100 | 30 | 50 | 2 | 4 |
| TEL100.50035 | 100 | 35 | 50 | 2 | 4 |
| TEL125.50040 | 125 | 40 | 50 | 2 | 4 |
| TEL125.50050 | 125 | 50 | 50 | 2 | 4 |

Spare parts:

| | Dimensions | Item |
|-------------|------------|------------|
| Knife | 50x12x1,5 | Z055.010.N |
| Wedge | L=46 | Z056.702.N |
| Wedge screw | M8x16 | Z051.810.R |
| Spur | 14x14x2 | Z055.007.N |
| Spur screw | M5x7 | Z051.701.R |

HW CUTTERHEAD WITH REVERSIBLE STRAIGHT KNIVES AND SPURS

ART. TF

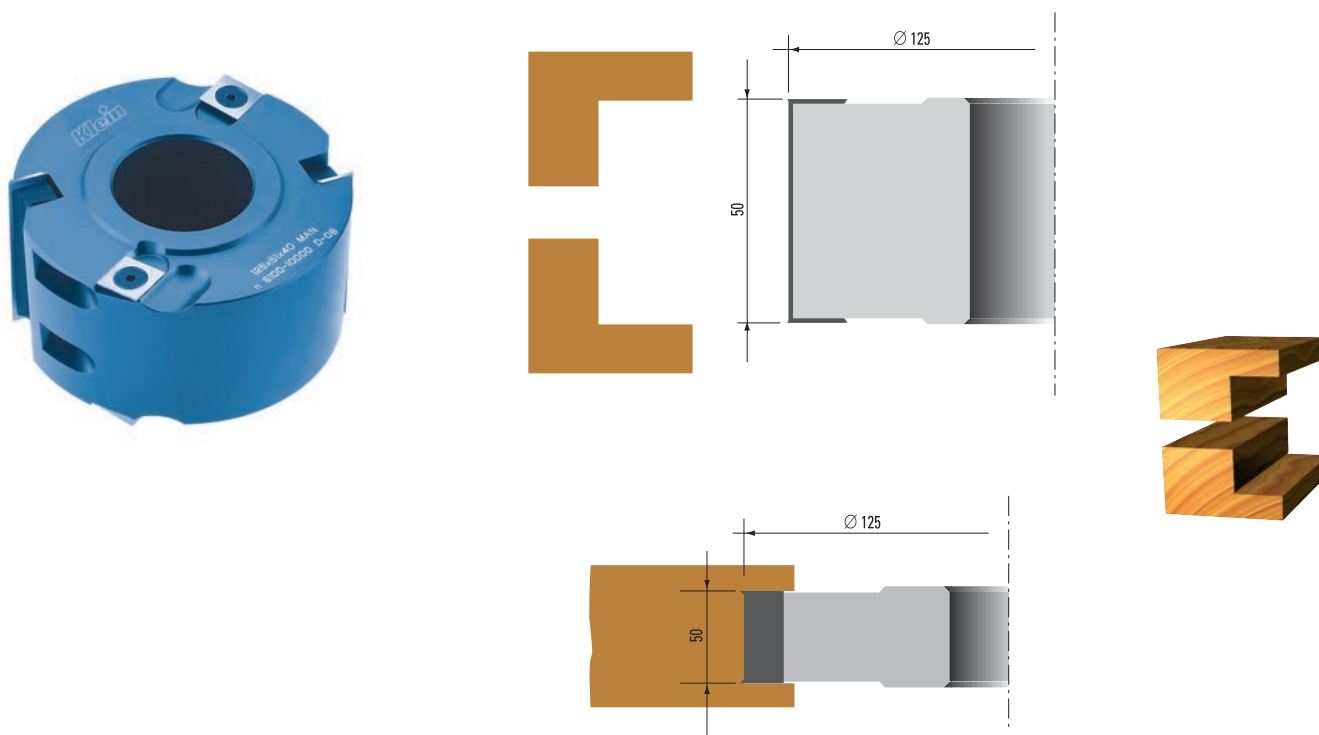

- Cutterhead for precision rebating straight cut, shear angle
- Steel body with reversible HW knives and spurs
- Manual feed (MAN)

| Item | D | d | B | Z | V |
|-------------|-----|----|----|---|---|
| TF125.30030 | 125 | 30 | 30 | 2 | 4 |
| TF125.30035 | 125 | 35 | 30 | 2 | 4 |
| TF125.30040 | 125 | 40 | 30 | 2 | 4 |
| TF125.30050 | 125 | 50 | 30 | 2 | 4 |
| TF125.50030 | 125 | 30 | 50 | 2 | 4 |
| TF125.50035 | 125 | 35 | 50 | 2 | 4 |
| TF125.50040 | 125 | 40 | 50 | 2 | 4 |
| TF125.50050 | 125 | 50 | 50 | 2 | 4 |
| TF125.50130 | 125 | 30 | 50 | 4 | 4 |
| TF125.50135 | 125 | 35 | 50 | 4 | 4 |
| TF125.50140 | 125 | 40 | 50 | 4 | 4 |
| TF125.50150 | 125 | 50 | 50 | 4 | 4 |

| | TF125.300 | | TF125.500 | |
|-------------|------------|------------|------------|------------|
| | Dimensions | Item | Dimensions | Item |
| Knife | 30x12x1,5 | Z055.008.N | 50x12x1,5 | Z055.010.N |
| Wedge | L=26 | Z056.703.N | L=46 | Z056.702.N |
| Wedge screw | M7x21 | Z051.801.R | M7x21 | Z051.801.R |
| Spur | 14x14x2 | Z055.007.N | 14x14x2 | Z055.007.N |
| Spur screw | M5x7 | Z051.701.R | M5x7 | Z051.701.R |

REBATING-GROOVING SET

ART. TX

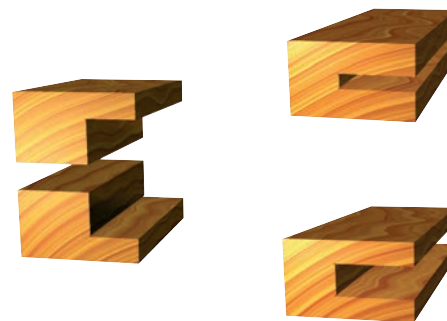
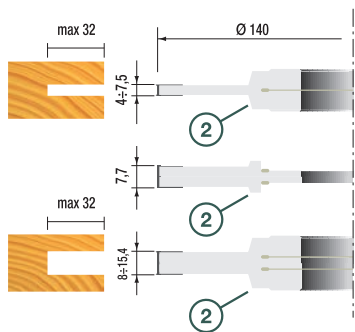
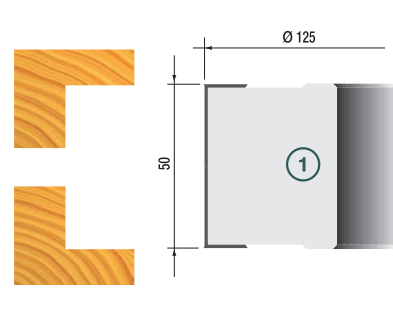
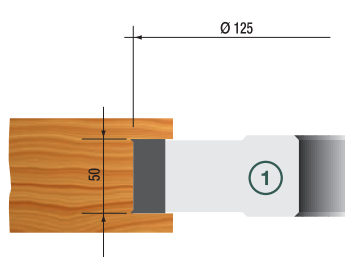

- Complete with: **TA140.15030**
TEL100.50030
- Manual feed (MAN)
- Available with bore 35

| Item | Description |
|--------|--|
| TX0001 | Rebating-grooving set in plastic case with bore 30 |

HW CUTTERHEAD FOR 45° BEVELS

ART. THL

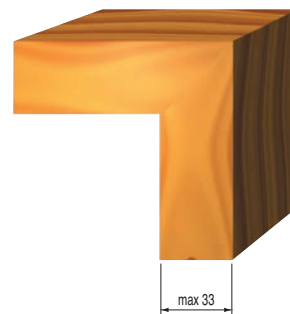
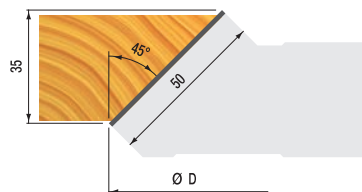

- Light alloy body for extremely accurate 45° bevels
- Reversible HW knives
- Manual feed (MAN)

| Item | D | d | B | Z |
|--------------|-----|----|----|---|
| THL150.36030 | 150 | 30 | 36 | 2 |
| THL150.36035 | 150 | 35 | 36 | 2 |

Spare parts:

| | Dimensions | Item |
|------------|------------|------------|
| Knife | 50x12x1,5 | Z055.010.N |
| Wedge | - | Z056.704.N |
| Wedge stop | - | Z056.800.N |
| Screw | M8x21 | Z051.802.R |

HW ADJUSTABLE BEVEL CUTTERHEAD

ART. TI

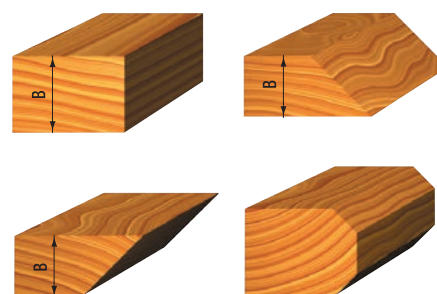
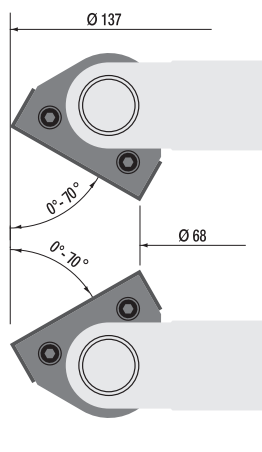

- Bevel cutterhead, adjustable by 1° on a scale
- Adjustment + 70° - 70°
- Steel tool body with HW reversible knives
- Manual feed (MAN)

| Item | D | d | B | Z | α |
|-------------|-----|----|----|---|-------------|
| TI160.50030 | 160 | 30 | 50 | 2 | 0+70°/0-70° |
| TI160.50035 | 160 | 35 | 50 | 2 | 0+70°/0-70° |
| TI160.50040 | 160 | 40 | 50 | 2 | 0+70°/0-70° |
| TI170.50050 | 170 | 50 | 50 | 2 | 0+70°/0-70° |

Spare parts:

TI160.500

TI170.500

| | Dimensions | Item |
|-------------|------------|------------|
| Knife | 50x12x1,5 | Z055.010.N |
| Wedge | L=47 | Z056.706.N |
| Wedge screw | M6x12 | Z051.804.R |

HW ADJUSTABLE BEVEL CUTTERHEAD

ART. TIL

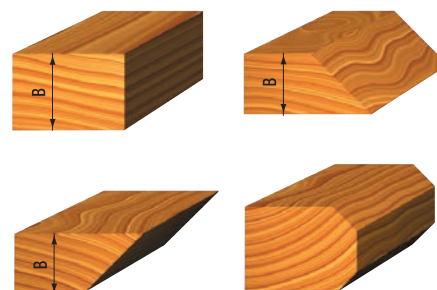
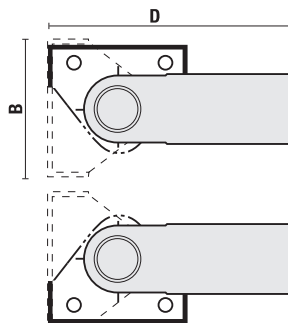

- Inclination between 0° and 90°
- Bevel cutterhead adjustable every 7,5°
- Produced in light alloy complete with HW knives
- Manual feed (MAN)

| Item | D | d | B | Z |
|-------------------------|-----|----|----|---|
| TIL140.50030 NEW | 140 | 30 | 50 | 2 |
| TIL140.50035 NEW | 140 | 35 | 50 | 2 |
| TIL160.50040 NEW | 160 | 40 | 50 | 2 |
| TIL160.50050 NEW | 160 | 50 | 50 | 2 |

Spare parts:

| | Dimensions | Item |
|-------------|------------------|------------|
| Knife | 50x12x1,5 | Z055.010.N |
| Wedge screw | M4x10 - Torx T15 | Z051.811.R |

HW TOOLING SET FOR ROUNDING AND CHAMFERING

ART. TLL

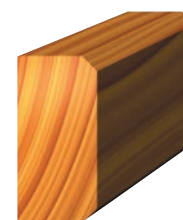
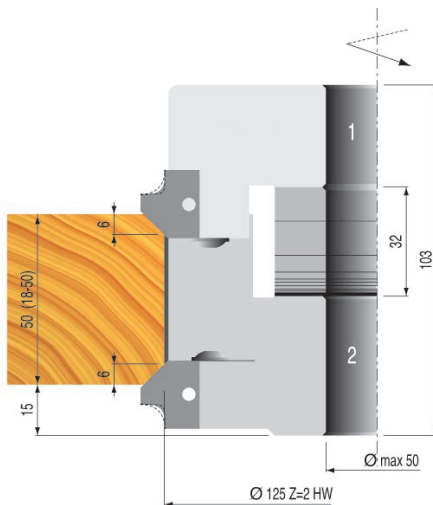
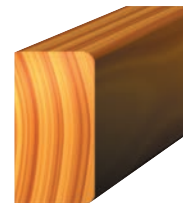
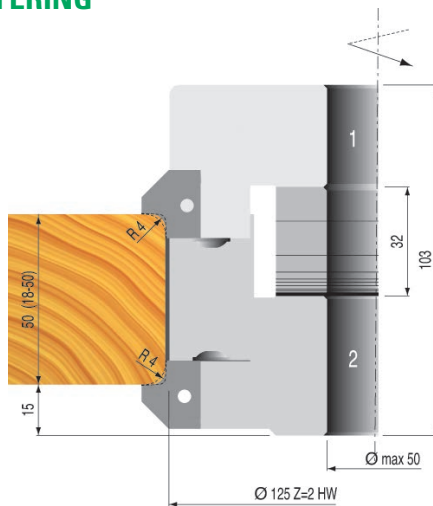

- Set of cutterhead for round profiles (R=2-3-4-5-6) on one side and 45° chamfer on the other
- Produced in light alloy complete with HW replaceable knives, spacing rings and two flanges for manual feeding
- Available also with bore 35/40/50

| Item | D | d | B | Z | R | α |
|--------------|-----|----|-------|---|---|-----|
| TLL139.50230 | 139 | 30 | 15÷50 | 2 | 2 | 45° |
| TLL139.50330 | 139 | 30 | 15÷50 | 2 | 3 | 45° |
| TLL139.50430 | 139 | 30 | 15÷50 | 2 | 4 | 45° |
| TLL139.50530 | 139 | 30 | 15÷50 | 2 | 5 | 45° |
| TLL139.50630 | 139 | 30 | 15÷50 | 2 | 6 | 45° |

TLL139 diameter 139 mm. bore 35 mm. (code number ends with 35 instead of 30)
TLL139 diameter 139 mm. bore 40 mm. (code number ends with 40 instead of 30)
TLL139 diameter 139 mm. bore 50 mm. (code number ends with 50 instead of 30)

Spare parts:

| | Dimensions | Item |
|----------------------|------------|------------|
| Knife | 50x12x1,5 | Z055.010.N |
| Wedge | - | Z056.707.N |
| Wedge screw | M8x20 | Z051.805.R |
| Top profile knife | R=2/45° | Z055.800.R |
| Bottom profile knife | R=2/45° | Z055.800.L |
| Top profile knife | R=3/45° | Z055.801.R |
| Bottom profile knife | R=3/45° | Z055.801.L |
| Top profile knife | R=4/45° | Z055.802.R |
| Bottom profile knife | R=4/45° | Z055.802.L |
| Top profile knife | R=5/45° | Z055.803.R |
| Bottom profile knife | R=5/45° | Z055.803.L |
| Top profile knife | R=6/45° | Z055.804.R |
| Bottom profile knife | R=6/45° | Z055.804.L |
| Wedge | - | Z056.708.N |
| Wedge screw | M8x20 | Z051.805.R |

HW MULTIRADIUS SET

ART. TML

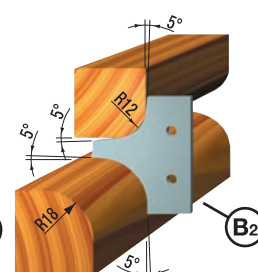
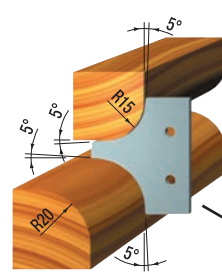
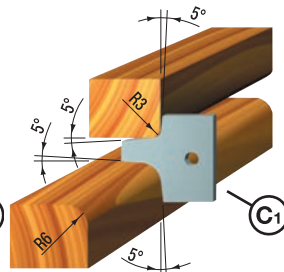
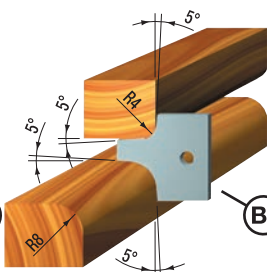
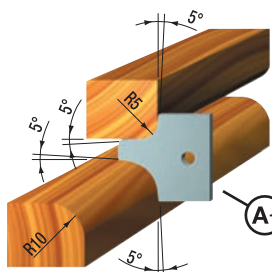
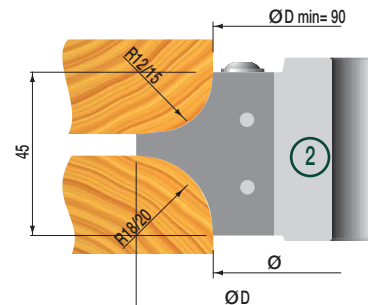
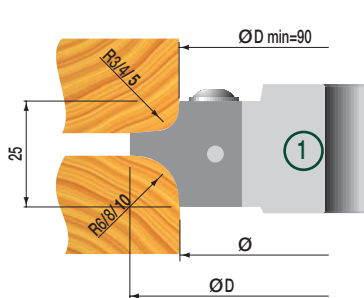

- Cutterhead with two radius knives mounted on the tools
- Produced in light alloy with HW knives
- Manual feed (MAN)
- Available also with bore 35

| Item | D | d | B | Z | R |
|--------------|-----|----|----|---|------|
| TML113.25330 | 113 | 30 | 25 | 2 | 3/6 |
| TML113.25430 | 113 | 30 | 25 | 2 | 4/8 |
| TML113.25530 | 113 | 30 | 25 | 2 | 5/10 |

TML113 diameter 113 mm. bore 35 mm. (code number ends with 35 instead of 30)

| | | | | | |
|--------------|-----|----|----|---|-------|
| TML132.45230 | 132 | 30 | 45 | 2 | 12/18 |
| TML132.45530 | 132 | 30 | 45 | 2 | 15/20 |

TML132 diameter 132 mm. bore 35 mm. (code number ends with 35 instead of 30)

| Spare parts: | TML113.25 | | TML132.45 | |
|---------------|------------|------------|-------------|------------|
| | Dimensions | Item | Dimensions | Item |
| Profile knife | R= 3/6 A1 | Z055.805.R | R= 12/18 A2 | Z055.808.R |
| Profile knife | R= 4/8 B1 | Z055.806.R | R= 15/20 B2 | Z055.809.R |
| Profile knife | R= 5/10 C1 | Z055.807.R | - | - |
| Wedge | - | Z056.709.N | - | Z056.710.N |
| Wedge screw | M8x20 | Z051.805.R | M8x20 | Z051.805.R |



Art. **TX0002** complete with: **TML113.25330** +
2 pcs. Z055.806.R +
2 pcs. Z055.807.R

Art. **TX0003** complete with: **TML132.45230** +
2 pcs. Z055.808.R
2 pcs. Z055.809.R

Available with bore 35

| Item | Description |
|--------|--|
| TX0002 | Set in plastic box complete with cutterhead + 2 profile knives each R= 3/6 + R= 4/8 + R= 5/10 (bore 35 on request) |
| TX0003 | Set in plastic box complete with cutterhead + 2 profile knives each R= 12/18 + R= 15/20 (bore 35 on request) |

HW TOOLING SET FOR CONCAVE AND CONVEX QUARTER ROUNDS

ART. TNL

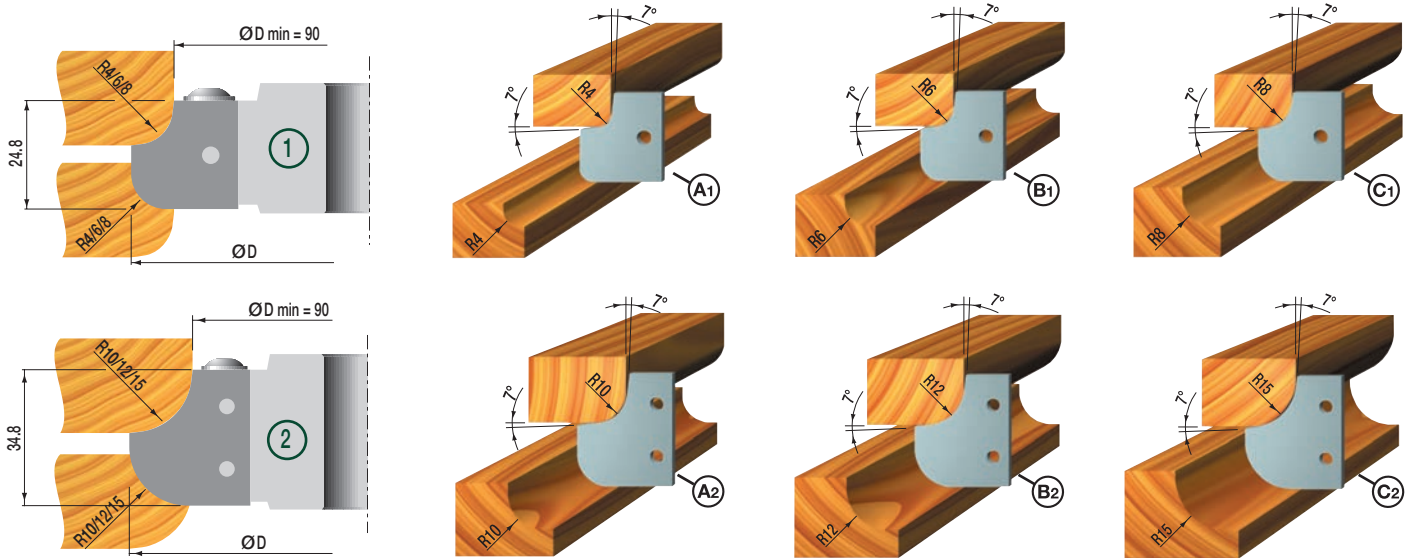

- Cutterhead with two radius knives mounted on the tools
- Produced in light alloy with HW knives
- Manual feed (MAN)
- Available also with bore 35

| Item | D | d | B | Z | R |
|--------------|-----|----|------|---|-------|
| TNL110.25430 | 109 | 30 | 24,8 | 2 | 4-4 |
| TNL110.25630 | 109 | 30 | 24,8 | 2 | 6-6 |
| TNL110.25830 | 109 | 30 | 24,8 | 2 | 8-8 |
| TNL122.35030 | 122 | 30 | 34,8 | 2 | 10-10 |
| TNL122.35230 | 122 | 30 | 34,8 | 2 | 12-12 |
| TNL122.35530 | 122 | 30 | 34,8 | 2 | 15-15 |

TNL122 diameter 122 mm. bore 35 mm. - R 10=15 (code number ends with 35 instead of 30)

| Spare parts: | TNL110.25 | | TNL122.35 | |
|---------------|------------|------------|-------------|------------|
| | Dimensions | Item | Dimensions | Item |
| Profile knife | R= 4/4 A1 | Z055.810.R | R= 10/10 A2 | Z055.813.R |
| Profile knife | R= 6/6 B1 | Z055.811.R | R= 12/12 B2 | Z055.814.R |
| Profile knife | R= 8/8 C1 | Z055.812.R | R= 15/15 C2 | Z055.815.R |
| Wedge | - | Z056.710.N | - | Z056.711.N |
| Wedge screw | M8x20 | Z051.805.R | M8x20 | Z051.805.R |



Art. **TX0004** complete with: **TNL110.25430** +
2 pcs. Z055.811.R +
2 pcs. Z055.812.R

Art. **TX0005** complete with: **TNL122.35030** +
2 pcs. Z055.814.R +
2 pcs. Z055.815.R

Available with bore 35

| Item | Description |
|--------|---|
| TX0004 | Set in plastic box complete with cutterhead + 2 profile knives each R= 4/4 + R= 6/6 + R= 8/8 (bore 35 on request) |
| TX0005 | Set in plastic box complete with cutterhead + 2 profile knives each R= 10/10 + R= 12/12 + R= 15/15 (bore 35 on request) |

MULTIPROFILE SET

ART. TX

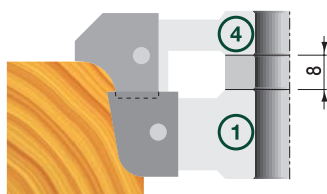
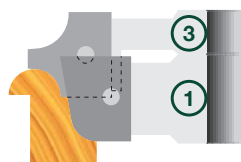
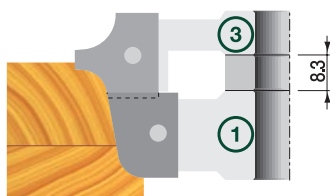
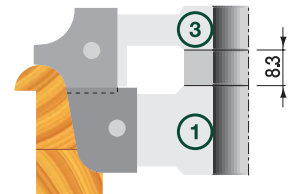
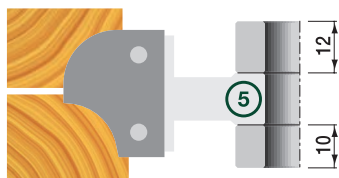
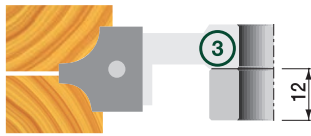
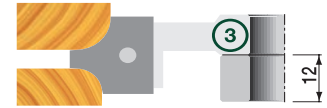

MULTIPROFILE SET

ART. TX

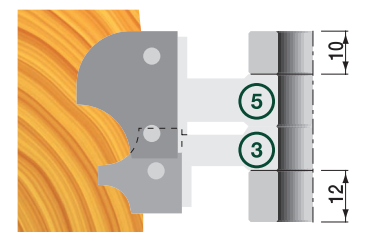
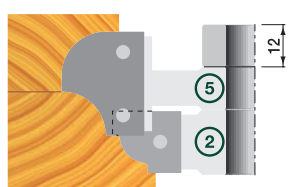
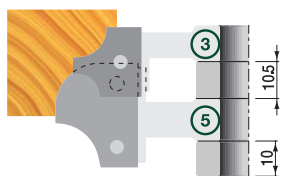
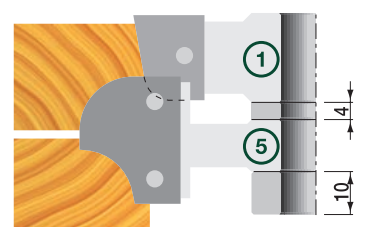
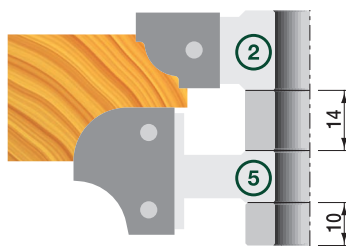
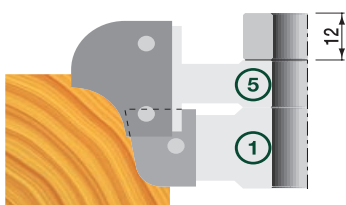
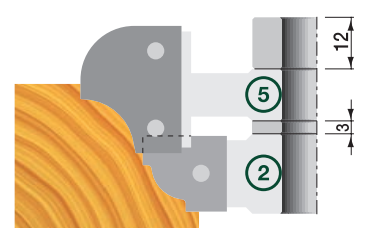
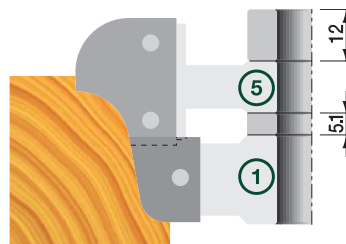
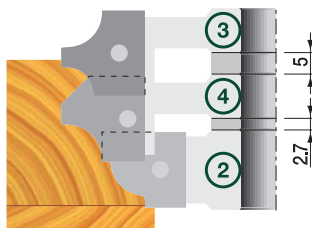
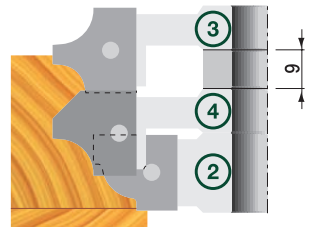
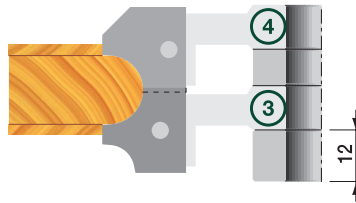
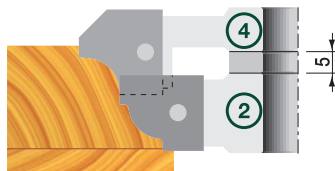
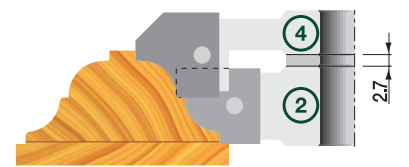
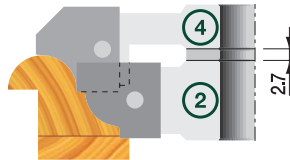
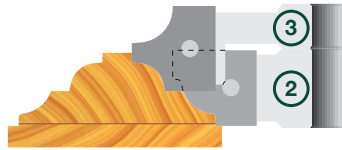
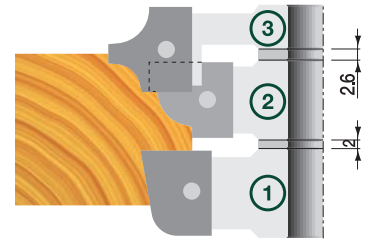
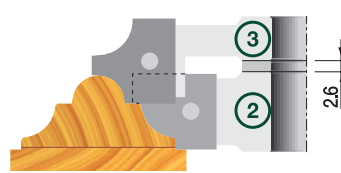

MULTIPROFILE SET

ART. TX

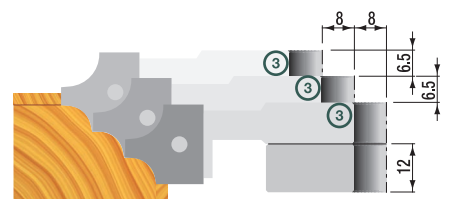
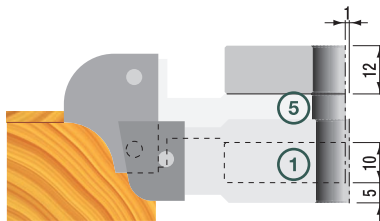
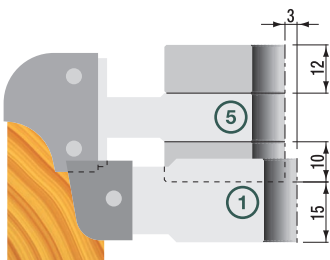
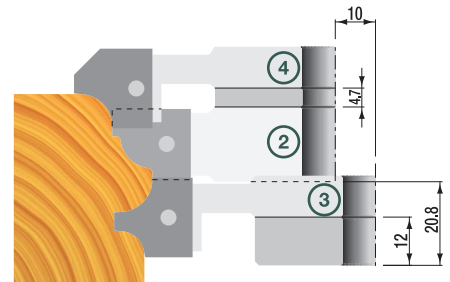
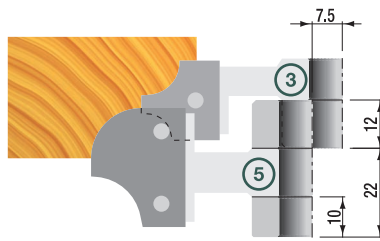
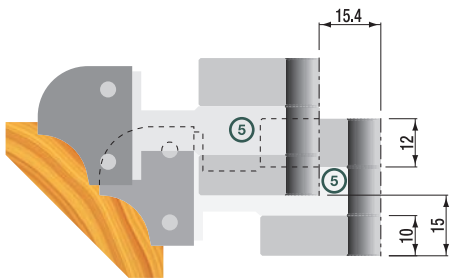
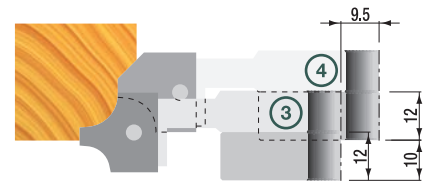
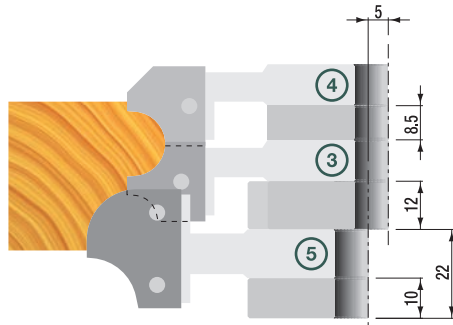
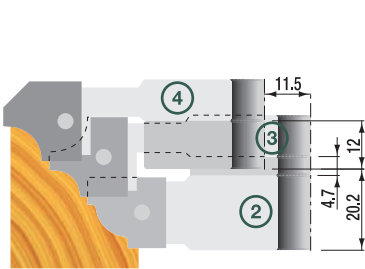
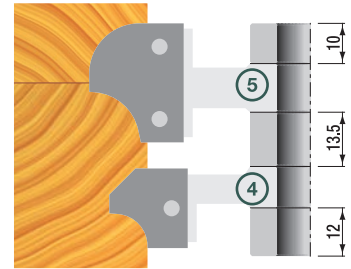
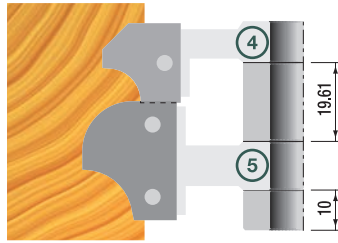
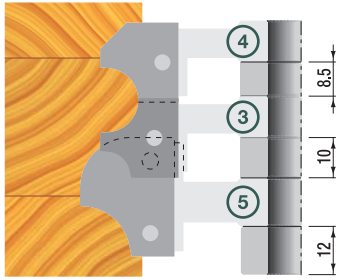

HW MITRE JOINT CUTTERHEAD 45°

ART. TSL

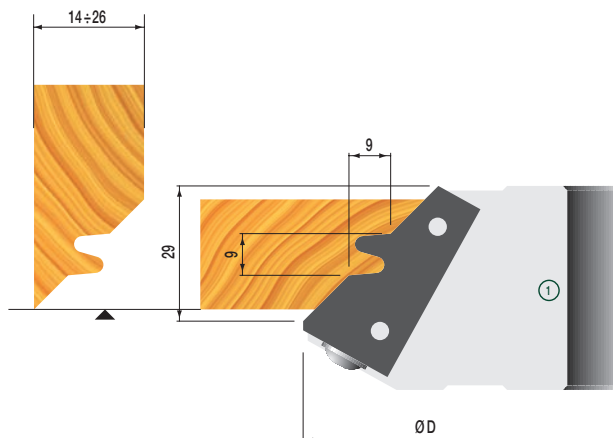

- Produced in light alloy with HW knives
- Manual feed (MAN)

| Item | D | d | B | Z |
|--------------|-----|----|----|---|
| TSL140.32030 | 140 | 30 | 32 | 2 |
| TSL140.32035 | 140 | 35 | 32 | 2 |
| TSL140.32040 | 140 | 40 | 32 | 2 |

Spare parts:

| | Dimensions | Item |
|-------------|------------|------------|
| Knife | 50x22,5x2 | Z055.830.R |
| Wedge | - | Z056.719.N |
| Wedge stop | - | Z056.800.R |
| Wedge screw | M8X20 | Z051.805.R |

HW PROFILE CUTTER

ART. TS

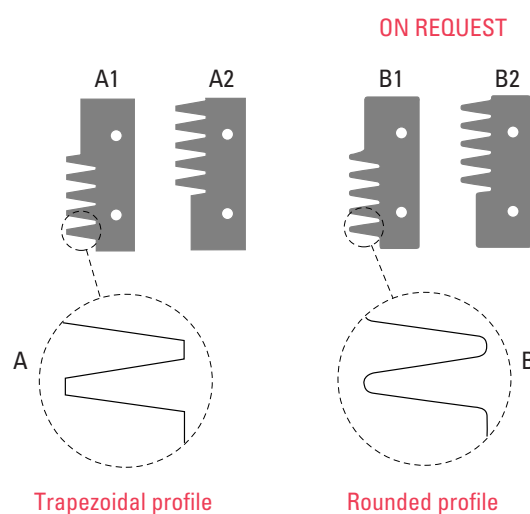
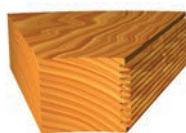
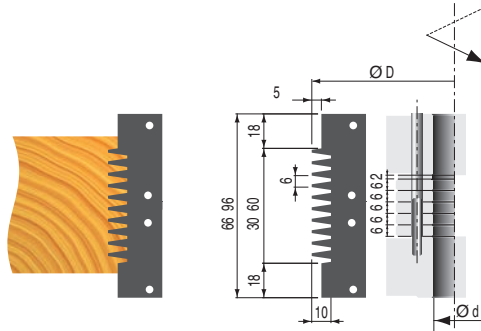

- Steel body with HW knives
- Adjustable by means of spacers
- Suitable for arch windows
- Manual feed (MAN)

| Item | D | d | B | Z | Profile |
|-------------|-----|----|-------|-----|---------|
| TS140.96030 | 140 | 30 | 66÷96 | 2+2 | A |
| TS140.96035 | 140 | 35 | 66÷96 | 2+2 | A |
| TS140.96040 | 140 | 40 | 66÷96 | 2+2 | A |

Spare parts:

| | Dimensions | Item |
|------------|------------|------------|
| Knife "A1" | 50x22,5x2 | Z055.861.N |
| Knife "A2" | 50x22,5x2 | Z055.862.N |
| Knife "B1" | 50x22,5x2 | Z055.863.N |
| Knife "B2" | 50x22,5x2 | Z055.864.N |
| Wedge | L= 46 | Z056.726.N |
| Screw | M8X20 | Z051.805.R |

HW PANEL RAISING SET WITH SIX PROFILES

ART. TTL



- Produced in light alloy with HW knives
- Six knives for working 12 different wood profiles (profiles "A" - "B" - "C" - "D" - "E" - "F")
- Manual feed (MAN)
- Available only with bore 30

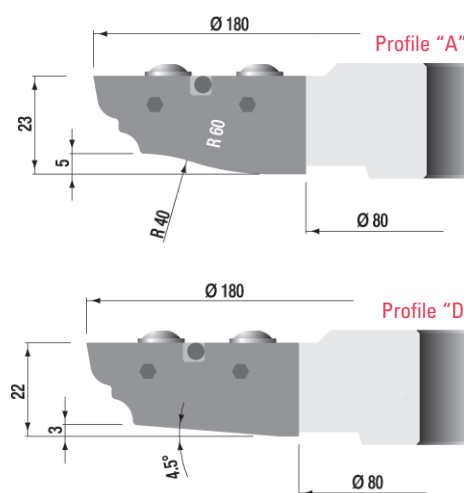

| Item | D | d | B | Profile | Z |
|--------------|-----|----|----|---------|---|
| TTL180.22130 | 180 | 30 | 22 | D | 2 |
| TTL180.22230 | 180 | 30 | 22 | E | 2 |
| TTL180.22330 | 180 | 30 | 22 | F | 2 |
| TTL180.23130 | 180 | 30 | 23 | A | 2 |
| TTL180.23230 | 180 | 30 | 23 | B | 2 |
| TTL180.23330 | 180 | 30 | 23 | C | 2 |

Spare parts:

| | Dimensions | Item |
|---------------|-------------|------------|
| Profile knife | Profile "A" | Z055.831.R |
| Profile knife | Profile "B" | Z055.832.R |
| Profile knife | Profile "C" | Z055.833.R |
| Profile knife | Profile "D" | Z055.834.R |
| Profile knife | Profile "E" | Z055.835.R |
| Profile knife | Profile "F" | Z055.836.R |
| Screw | M5x10 | Z051.702.R |

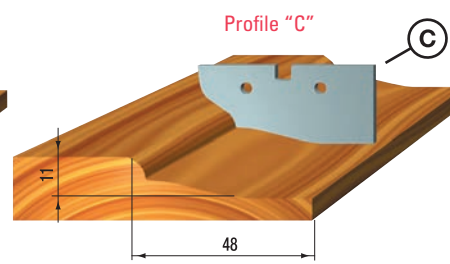
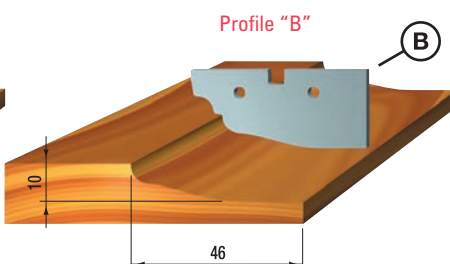
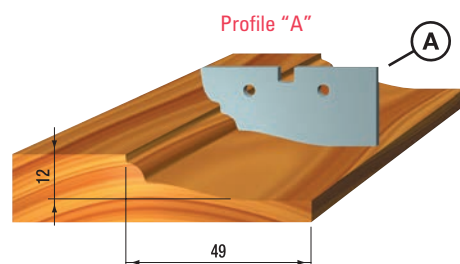
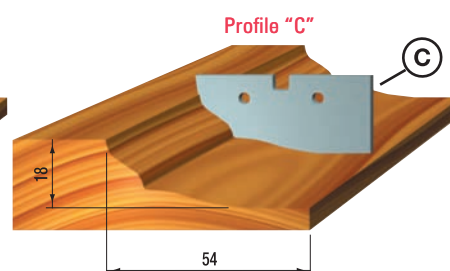
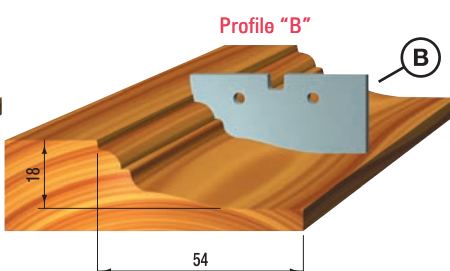
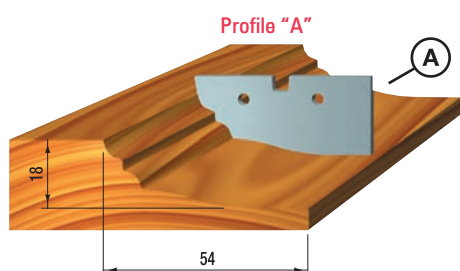
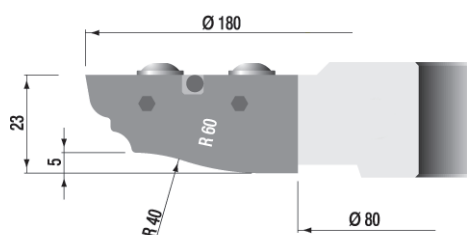

See profiles "D" - "E" - "F" →

HW PANEL RAISING SET WITH SIX PROFILES

ART. TTL

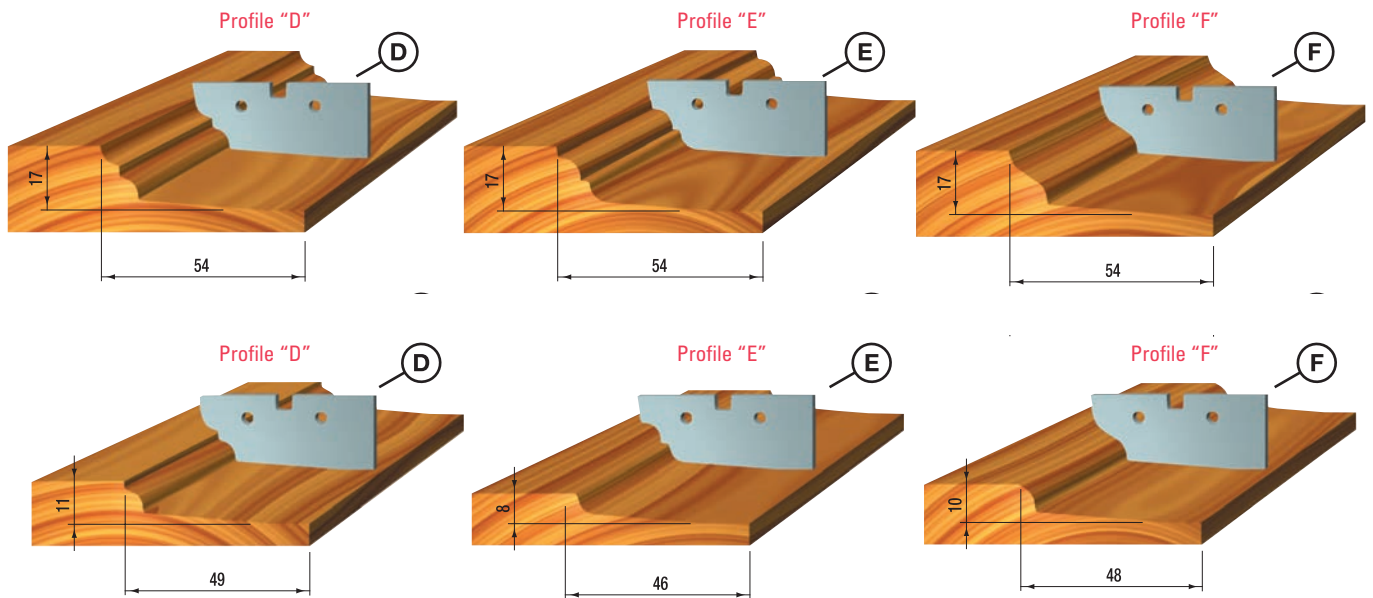
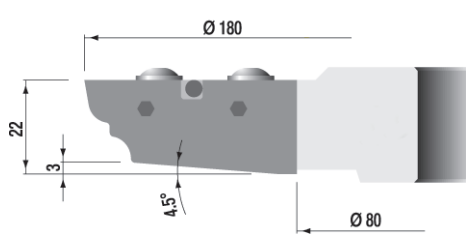

HW PANEL RAISING SET

ART. TX



Art. **TX0010** complete with: **TTL180.22130** +
2 pz. Z055.835.R +
2 pz. Z055.836.R

Art. **TX0011** complete with: **TTL180.23130** +
2 pz. Z055.832.R +
2 pz. Z055.833.R

Available only with bore 30

| Item | Description |
|--------|--|
| TX0010 | Set in plastic box with cutterhead + 2 profile knives each - Profile D + E + F |
| TX0011 | Set in plastic box with cutterhead + 2 profile knives each - Profile A + B + C |

HW PANEL RAISING SET

ART. TWL

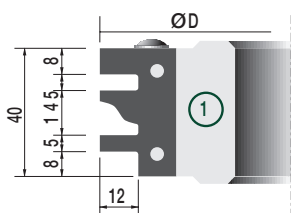
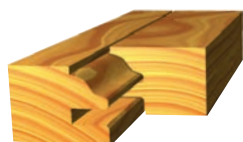

Profile "A"

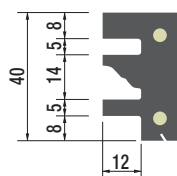

Profile "B"

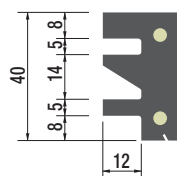

Profile "C"

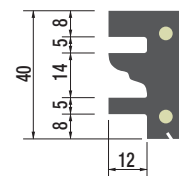

Profile "D"

- Cutterhead for profile and counter profile cutting
- Produced in light alloy with HW knives and shear angle
- The tool body fits 4 different profile knives
- Manual feed (MAN)
- Available also with bore 35/40

| Item | D | d | B | Profile | Z |
|--------------|-----|----|----|---------|---|
| TWL120.40130 | 120 | 30 | 40 | A | 2 |
| TWL120.40230 | 120 | 30 | 40 | B | 2 |
| TWL120.40330 | 120 | 30 | 40 | C | 2 |
| TWL120.40430 | 120 | 30 | 40 | D | 2 |

TWL120 diameter 120 mm. bore 35 mm. (code number ends with 35 instead of 30)

TWL120 diameter 120 mm. bore 40 mm. (code number ends with 40 instead of 30)

Spare parts:

| | Dimensions | Item |
|---------------|-------------|------------|
| Profile knife | profile "A" | Z055.843.R |
| Profile knife | profile "B" | Z055.844.R |
| Profile knife | profile "C" | Z055.845.R |
| Profile knife | profile "D" | Z055.846.R |
| Wedge | - | Z056.723.N |
| Wedge screw | M6X25 | Z051.808.R |

HW PANEL RAISING SET

ART. TVL

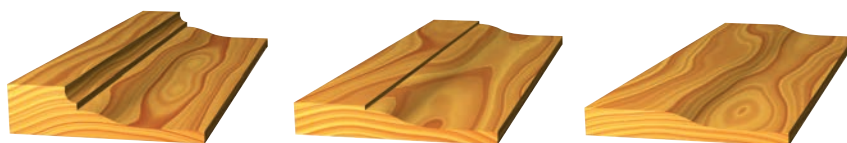
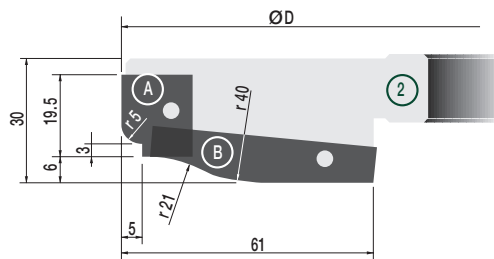

- Produced in light alloy with HW knives
- Manual feed (MAN)

| Item | D | d | B | Z |
|--------------|-----|----|----|-----|
| TVL185.30030 | 185 | 30 | 30 | 2+2 |
| TVL185.30035 | 185 | 35 | 30 | 2+2 |

Spare parts:

| | Dimensions | Item |
|---------------|-------------|------------|
| Profile knife | profile "A" | Z055.841.R |
| Wedge | - | Z056.721.N |
| Wedge screw | M6X25 | Z051.808.R |
| Profile knife | profile "B" | Z055.842.R |
| Wedge | - | Z056.722.N |
| Wedge screw | M6X25 | Z051.808.R |

COUNTERPROFILE-RAISING PANEL SET

ART. TX

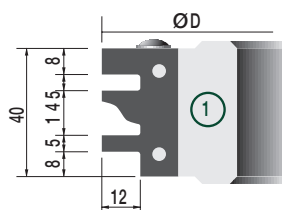
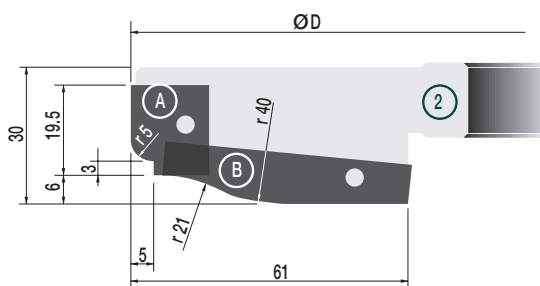

Complete with: **TVL185.30030**
TWL120.40130

| Item | |
|--------|--|
| TX0012 | Counterprofile-raising panel set in plastic box (on request bore 35/40/50) |

HW TOOLING SET FOR PROFILES AND COUNTERPROFILES

ART. TYL

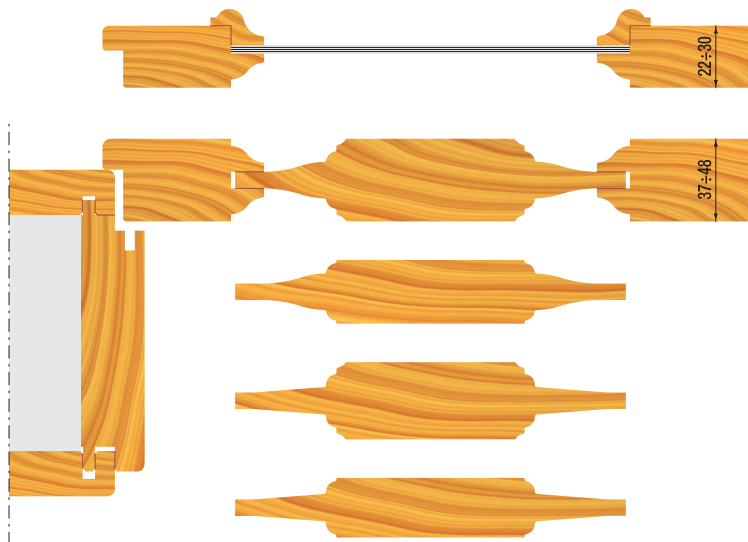
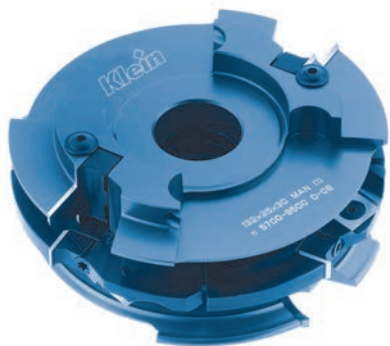

- Tool set for the production of doors (profile and counterprofile)
- Produced in light alloy with HW knives
- Complete with 3 cutterheads, adjustment spacer rings and two safety flanges
- The adjustable groover can be used separately
- Manual feed (MAN)
- Available also with bore 35

| Item | D | d | B | Profile | V | Z |
|--------------|-----|----|----|---------|---|---|
| TYL132.25130 | 132 | 30 | 50 | A1+A2 | 2 | 4 |
| TYL132.25230 | 132 | 30 | 50 | B1+B2 | 2 | 4 |
| TYL132.25330 | 132 | 30 | 50 | C1+C2 | 2 | 4 |
| TYL132.25430 | 132 | 30 | 50 | D1+D2 | 2 | 4 |
| TYL132.25530 | 132 | 30 | 50 | E1+E2 | 2 | 4 |

TYL132 diameter 132 mm. bore 35 mm. (code number ends with 35 instead of 30)

Spare parts:

| | Dimensions | Item |
|--------------------------|------------|------------|
| Profile knife | Prof. "A1" | Z055.851.R |
| Profile knife | Prof. "A2" | Z055.852.R |
| Profile knife | Prof. "B1" | Z055.853.R |
| Profile knife | Prof. "B2" | Z055.854.R |
| Profile knife | Prof. "C1" | Z055.855.R |
| Profile knife | Prof. "C2" | Z055.856.R |
| Profile knife | Prof. "D1" | Z055.857.R |
| Profile knife | Prof. "D2" | Z055.858.R |
| Profile knife | Prof. "E1" | Z055.859.R |
| Profile knife | Prof. "E2" | Z055.860.R |
| Wedge for A1-B1-C1-D1-E1 | - | Z056.724.N |
| Wedge for A2-B2-C2-D2-E2 | - | Z056.725.N |
| Wedge screw | M6X20 | Z051.807.R |

HW TOOLING SET FOR PROFILES AND COUNTERPROFILES EXAMPLES

ART. TYL

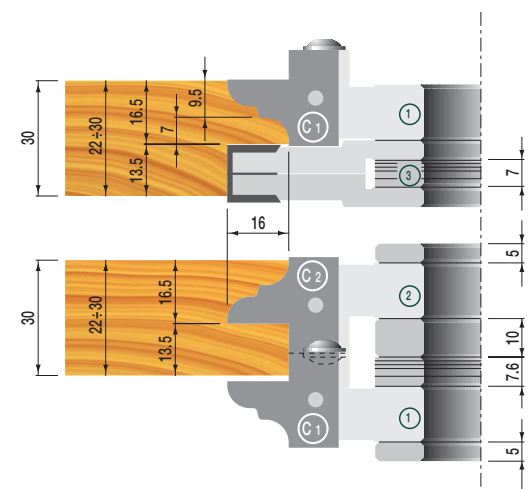
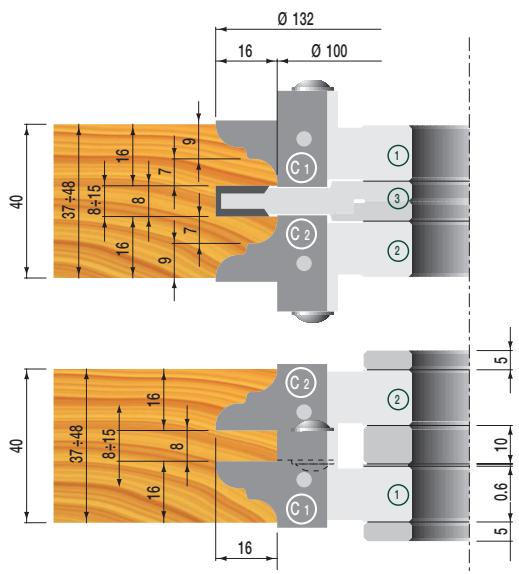
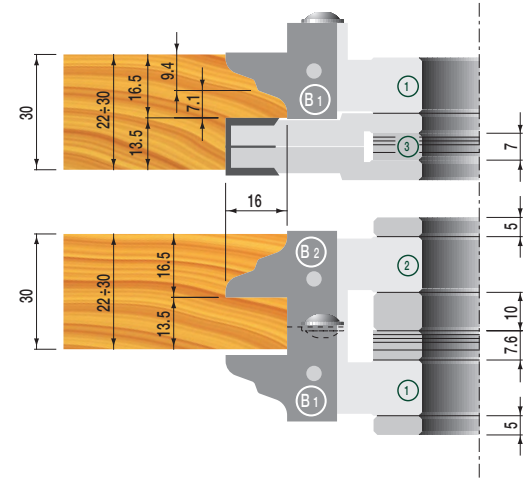
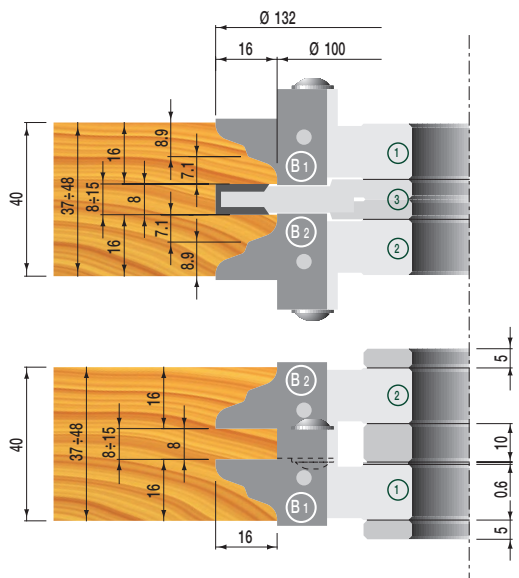
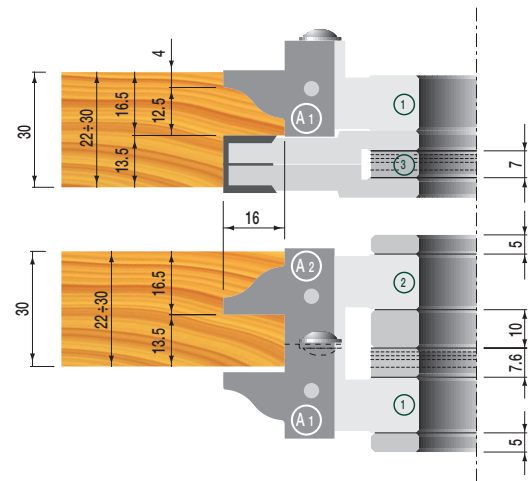
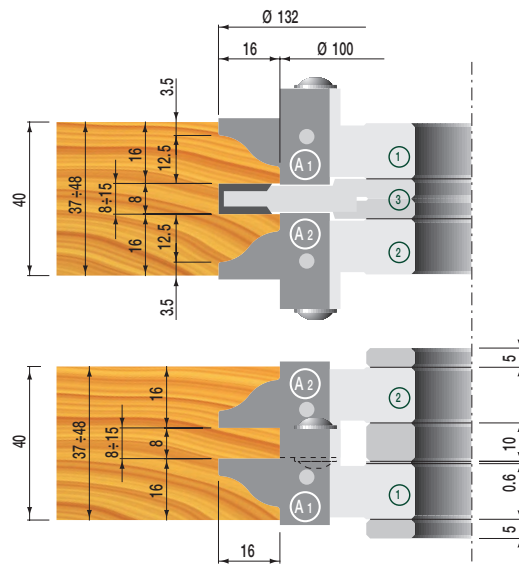

HW TOOLING SET FOR PROFILES AND COUNTERPROFILES EXAMPLES

ART. TYL

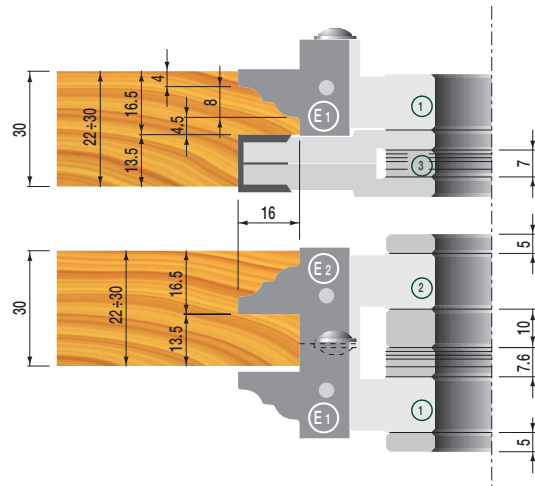
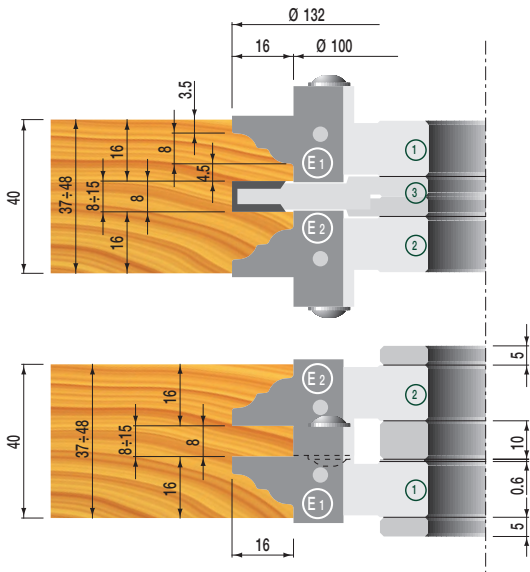
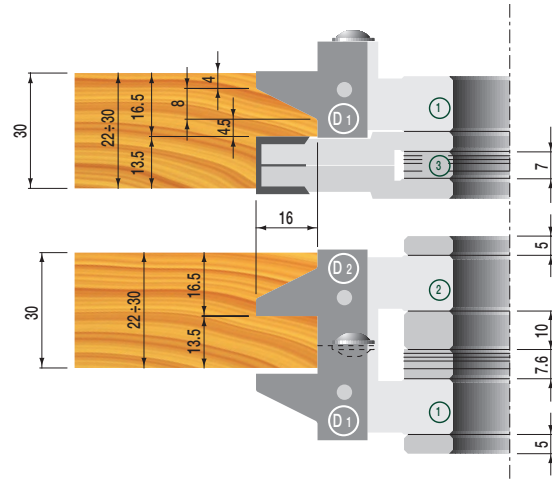
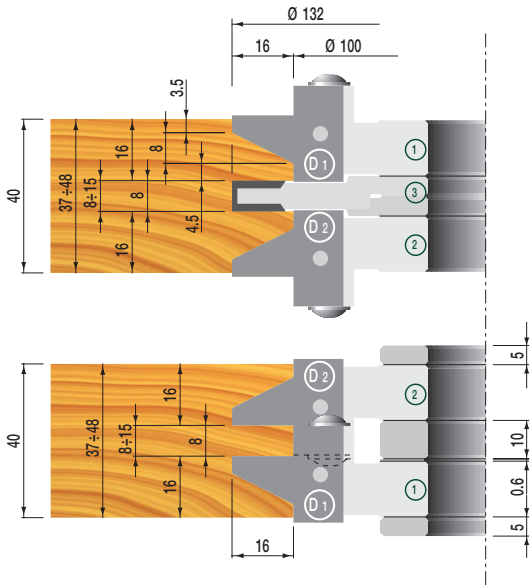

TONGUE AND GROOVE TOOLING SET

ART. TZL

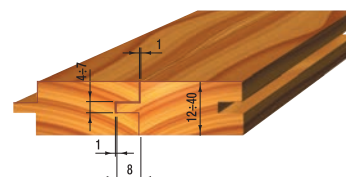
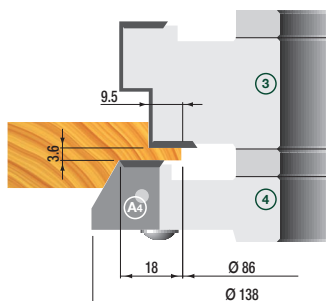
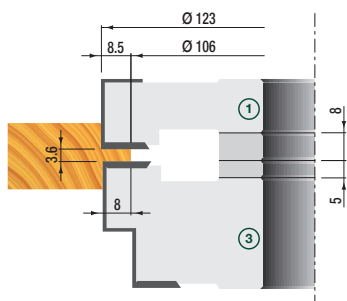
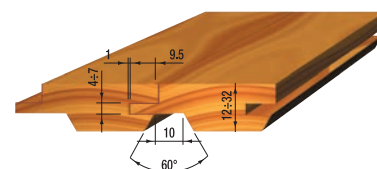
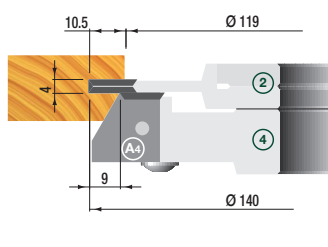
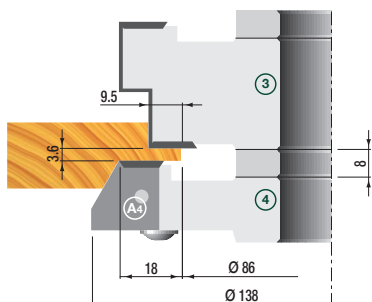
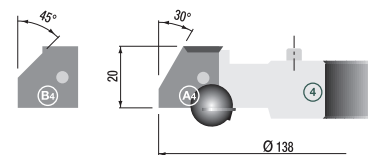
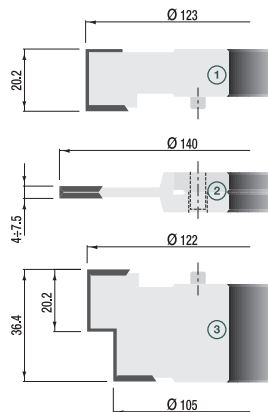
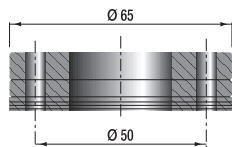

- Tool set for production of wall panels and various types of flooring
- Produced in light alloy with HW knives
- Complete with 4 cutterheads and spacers rings, packed in plastic case
- Manual feed (MAN)

| Item | D | d | Bmax | Z | V |
|--------------|-----|----|------|---|---|
| TZL138.40030 | 138 | 30 | 40 | 2 | 4 |
| TZL138.40035 | 138 | 35 | 40 | 2 | 4 |

Spare parts:

| | Dimensions | Item |
|-------------|------------|------------|
| Knife "1" | 20x12x1,5 | Z055.003.N |
| Knife "3" | 20x12x1,5 | Z055.003.N |
| Wedge | - | Z056.708.N |
| Wedge screw | M8x20 | Z051.805.R |
| Spur "1" | 14x4x2 | Z055.007.N |
| Spur "3" | 14x4x2 | Z055.007.N |
| Spur screw | M5x7 | Z051.701.R |
| Knife "4" | prof. "A4" | Z055.847.R |
| Knife "4" | prof. "B4" | Z055.848.R |
| Wedge | - | Z056.708.N |
| Wedge screw | M8x20 | Z051.805.R |
| Spur "4" | 14x4x2 | Z055.007.N |
| Spur screw | M5x7 | Z051.701.R |

PLANERHEAD

ART. TZA

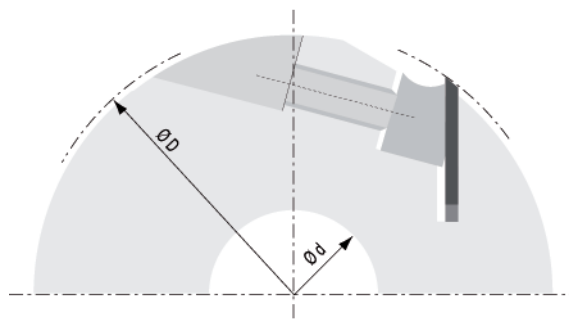

- Produced in light alloy with HS knives (18%W) - 30x3
- Planer knives positioning by means of aligners Art. Y200.125.N (page 11.11)
- Can be equipped with HW knives on request

| Item | D | d | B | Z |
|--------------|-----|----|-----|---|
| TZA125.12040 | 125 | 40 | 120 | 4 |
| TZA125.13040 | 125 | 40 | 130 | 4 |
| TZA125.15040 | 125 | 40 | 150 | 4 |
| TZA125.18040 | 125 | 40 | 180 | 4 |
| TZA125.23040 | 125 | 40 | 230 | 4 |

Spare parts:

| Item | |
|------------|-------------------|
| Z056.760.N | Wedge L= 120 |
| Z056.761.N | Wedge L= 130 |
| Z056.762.N | Wedge L= 150 |
| Z056.763.N | Wedge L= 180 |
| Z056.764.N | Wedge L= 230 |
| Z051.809.R | Wedge screw M8x18 |
| Z060.100.N | Pressure spring |

GUIDE BALL BEARINGS FOR SAWING OUT

ART. Z050

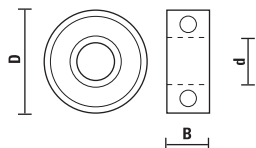

To be used with guide rings Art. Z058

| Item | D | d | B |
|------------|----|----|----|
| Z050.500.N | 62 | 30 | 16 |

GUIDE RINGS FOR BALL BEARING

ART. Z058

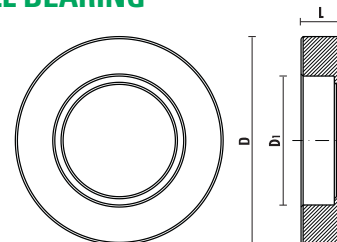

- Guide rings in **light alloy**
- Safety ring in **steel**

| Item | D | D1 | L | |
|------------|-------------|----|------|------|
| Z058.501.N | 70 | 62 | 21,5 | |
| Z058.502.N | 75 | 62 | 21,5 | |
| Z058.503.N | 80 | 62 | 21,5 | |
| Z058.504.N | 85 | 62 | 21,5 | |
| Z058.505.N | 90 | 62 | 21,5 | |
| Z058.506.N | 95 | 62 | 21,5 | |
| Z058.507.N | 100 | 62 | 21,5 | |
| Z058.508.N | 105 | 62 | 21,5 | |
| Z058.509.N | 110 | 62 | 21,5 | |
| Z058.510.N | 115 | 62 | 21,5 | |
| Z058.511.N | 120 | 62 | 21,5 | |
| Z058.512.N | 125 | 62 | 21,5 | |
| Z058.900.N | Safety ring | 68 | 30 | 21,5 |

REDUCTION RINGS FOR CUTTERHEADS

ART. ZA010

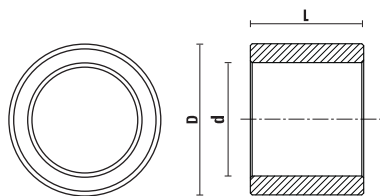

Tolerance:

D= 0/- 0,02

d= + 0,02/0

L= ± 0,02

| Item | D | d | L |
|--------------|----|----|----|
| ZA010.322020 | 32 | 20 | 20 |
| ZA010.353005 | 35 | 30 | 5 |
| ZA010.353010 | 35 | 30 | 10 |
| ZA010.353015 | 35 | 30 | 15 |
| ZA010.353020 | 35 | 30 | 20 |
| ZA010.353025 | 35 | 30 | 25 |
| ZA010.353030 | 35 | 30 | 30 |
| ZA010.353035 | 35 | 30 | 35 |
| ZA010.353040 | 35 | 30 | 40 |
| ZA010.403005 | 40 | 30 | 5 |
| ZA010.403010 | 40 | 30 | 10 |
| ZA010.403015 | 40 | 30 | 15 |
| ZA010.403020 | 40 | 30 | 20 |
| ZA010.403025 | 40 | 30 | 25 |
| ZA010.403030 | 40 | 30 | 30 |
| ZA010.403035 | 40 | 30 | 35 |
| ZA010.403040 | 40 | 30 | 40 |
| ZA010.403505 | 40 | 35 | 5 |
| ZA010.403510 | 40 | 35 | 10 |
| ZA010.403515 | 40 | 35 | 15 |
| ZA010.403520 | 40 | 35 | 20 |
| ZA010.403525 | 40 | 35 | 25 |
| ZA010.403530 | 40 | 35 | 30 |
| ZA010.403535 | 40 | 35 | 35 |
| ZA010.403540 | 40 | 35 | 40 |

REDUCING BUSHES

ART. ZA011

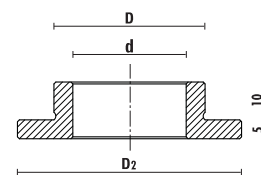

Tolerance:

D= 0/- 0,02

d= 0/- 0,02

| Item | D | d | D2 |
|-------------|----|----|----|
| ZA011.03530 | 35 | 30 | 55 |
| ZA011.04030 | 40 | 30 | 60 |
| ZA011.04035 | 40 | 35 | 55 |
| ZA011.05030 | 50 | 30 | 70 |
| ZA011.05035 | 50 | 35 | 70 |
| ZA011.05040 | 50 | 40 | 70 |

visit our website

www.sistemiklein.com



BALL BEARING WITH BUTTING RING SET

ART. TX

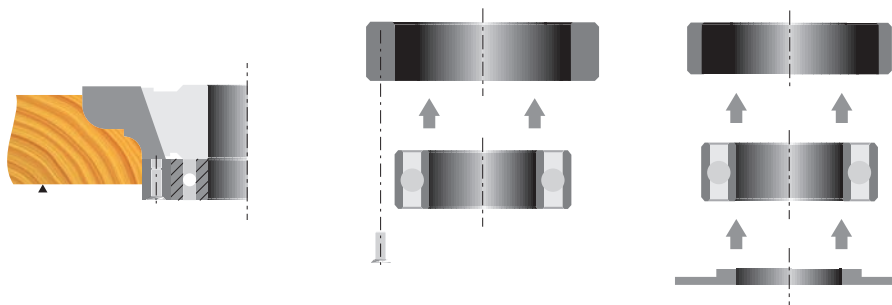

Item

TX0050

Complete with 6 pcs.:

Z050.500.N - 1 ball bearing

Z058.507.N - 1 guide ring D=100

Z058.501.N - 1 guide ring D=70

Z058.511.N - 1 guide ring D=125

Z058.505.N - 1 guide ring D=90

Z058.900.N - 1 safety ring D=68

Lubricants, diamond grinding wheels, diamond stones



14



KLEIN TOPUP
Pag. 14.03



KLEIN DRYUP
Pag. 14.03



KLEIN PROTECT
Pag. 14.03



KLEIN CLEANUP
Pag. 14.03



KLEIN WASHER
Pag. 14.03



KLEIN CLEANER
Pag. 14.03



4" DIAMOND WHETSTONE
Pag. 14.04



4" DIAMOND WHETSTONE
Pag. 14.04



MACHINIST POCKET WHETSTONE
Pag. 14.04

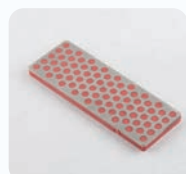

MACHINIST POCKET WHETSTONE
Pag. 14.04



MACHINIST POCKET WHETSTONE
Pag. 14.05



DIAFOLD DIAMOND WHETSTONE
Pag. 14.05



DIAFOLD DIAMOND FLAT FILE
Pag. 14.05



DIAFOLD SERRATED KNIFE SHARPENER
Pag. 14.05



6" 7/8" / 12" DIAMOND WHETSTONE
Pag. 14.06



DEMO-STAND
Pag. 14.06

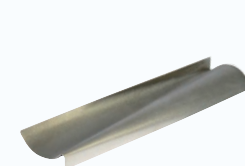

DIAMOND WAVE SHARPENERS FOR RADIUS CUTTERS
Pag. 14.07



8" DIAMOND WHETSTONE WITH BASE
Pag. 14.07

Klein®



DIAMOND WHETSTONE
Pag. 14.07



DIAMOND WHETSTONE
Pag. 14.07

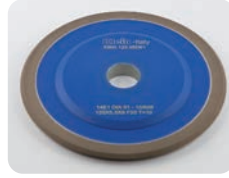

GRINDING WHEEL FOR ROUNDED
SPURS DOWEL DRILLS
Pag. 14.08

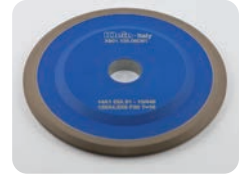

GRINDING WHEEL
FOR DOWEL DRILLS
Pag. 14.08



HIGH PERFORMANCE CUTTING DISC
Pag. 14.09



GRINDING WHEEL FOR HOLLOW
PARTS AND HOLES
Pag. 14.09

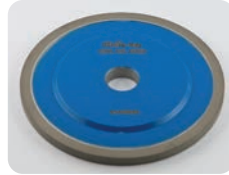

GENERAL PURPOSE STRAIGHT WHEEL
Pag. 14.09

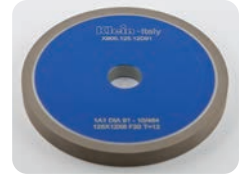

GENERAL PURPOSE
STRAIGHT WHEEL
Pag. 14.09



GRINDING WHEEL
FOR HW TIPPED CUTTERS
Pag. 14.09



GRINDING WHEEL
FOR PLANER KNIVES
Pag. 14.09



GRINDING WHEEL
FOR ROUTER CUTTERS
Pag. 14.10



GRINDING WHEEL
FOR ROUTER CUTTERS
Pag. 14.10



GRINDING WHEEL FOR HW TIPPED
SAWBLADES
Pag. 14.10

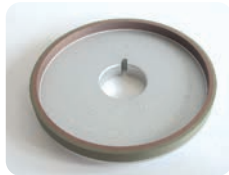

GRINDING WHEEL FOR HW TIPPED
SAWBLADES
Pag. 14.10

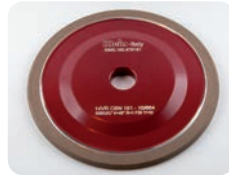

GRINDING WHEEL FOR BAND SAWBLADES
Pag. 14.10

The best for a proper maintenance

KleinTOPUP

Table and tool surface sealant



- Eliminates "hang-ups" on sliding surfaces
- Protects all tools and equipment from rust.
- Up to 30% slicker than paste wax.
- Prevents rust 5 times longer than paste wax or silicone.
- Easier and quicker to apply
- Contains no silicone or petroleum oil.
- Will not stain wood or interfere with glues or finishes.
- Perfect for table saws, drill presses, lathes, planers, band saws, mitres, panel saws and all hand tools.
- Environment-friendly, doesn't contain CFCs or any other ODS.

| Item | Description |
|----------------|-------------------|
| KLEINTOPUP.400 | Spray Can 400 ml. |

KleinDRYUP

Blade and bit cutting lubricant



- Prevents resin build-up.
- Reduces blade cleanings.
- Extends overall life of blades and bits by up to 3 times!
- More than doubles time between sharpenings.
- Contains NO silicone or petroleum oil. Will NOT stain wood or interfere with glues or finishes.
- Reduces cutting friction and heat by 30%.
- Prolongs equipments life by reducing saw or drill motor drag by up to 25%.
- Increases productivity by less downtime for saw blade changeovers.
- Works equally well on steel or carbide, stellite and diamond-tipped cutting blades.
- Environment-friendly, doesn't contain CFCs or any other ODS.

| Item | Description |
|----------------|-------------------|
| KLEINDRYUP.400 | Spray Can 400 ml. |

KleinPROTECT

Protective lubricant for cutting tools



- Removes easily and rapidly any residues of grease, coolants and synthetic compounds.
- If regularly used, protects and prevents from rust and corrosion
- Displaces moisture and condensation in case of difficult weather conditions.
- Extremely efficient on every metal surface
- Can be applied also on alloys containing copper, magnesium, nickel, steel, stainless steel, titanium and zinc, or polymers and elastomers.
- Can be used on all types of delicate machinery and mechanisms for weapons (according to U.S. Army specifications).

| Item | Description |
|-------------------|-------------------|
| KLEINPROTECT.400 | Spray Can 400 ml. |
| KLEINPROTECT.5000 | Liquid – Tank 5 L |

KleinCLEANUP

Detergent for cutting tools cleaning



- Water-based detergent for clearing tools
- Recommended for removing resin or sludge from tools
- No corrosive or dulling effect
- Not foaming
- Not flammable, doesn't contain solvents
- Non-toxic, not health-harming
- Biodegradable
- Suitable also for washers
- Can be used on any mechanical parts or tools also mounted on groups for windows

| Item | Description |
|--------------------|---------------------|
| KLEINCLEANUP.1000 | Liquid – Bottle 1 L |
| KLEINCLEANUP.10000 | Liquid – Tank 10 L |

KleinWASHER

Automatic Tool Washer

- Suitable for washing any metal parts and tools from the industry to the smaller workshop
- For tools of various dimensions, also for tool groups for windows thanks to its rotating tank with an height of 350 mm
- Heated biological operating mode
- To be used only with water-based detergent (see our item KleinCLEANUP)

Includes:

- Stainless steel housing
- Rotating tank D=600 mm
- Tank's capacity: 75 L
- Maximum payload: 100 kg
- Maximum height of the tools: 350mm
- Stainless steel upper, under and lateral washing arms
- Timer
- Thermal resistance
- Single-phase 1 hp pump
- Dimensions: 940x790 h930 mm
- Dimensions packing: 1210x1050 h1200 mm
- Weight: 65 kg

| Item |
|-------------|
| KLEINWASHER |



See section 16 page 16.19

KleinCLEANER

Manual Tool Washer

- Can wash any type of tools or metal parts
- Easy to be used with water and spray gun
- Heated biological operating mode

Includes:

- Spray gun
- Tool holding grid
- Stainless steel tank with thermal resistance
- Air-operated double diaphragm pump 5 L/min
- Tank dimensions: 600x500 h 250 mm
- Tank capacity: 70L
- Dimensions: 700x560 h1000 mm
- Dimensions packing: 970x670 h1020
- Weight: 30 Kg

| Item |
|--------------|
| KLEINCLEANER |



See section 16 page 16.19

DIAMOND WHETSTONE



Grind and spare!

A complete range of diamond stones for any kind of application
JUST DIAMOND CAN GIVE YOU THE EDGE OF PERFECTION!

- FAST** - Hardest material; most efficient sharpening abrasive
- EASY** - Light pressure produces a sharp edge with just a few strokes
- CLEAN** - Use water for lubricant - No oil, no mess!
- VERSATILE** - Hones all hard materials: carbide, steel, etc.
- DURABLE** - Stays flat



- **X-Coarse** Most rapid stock removed for dressing nicked or damaged knives and chisels or sharpening heavy cutting tools such as axes and lawnmower blades.
- **Coarse** Rapidly restores a sharp edge on dull knives and tools. Perfect for honing garden tools, sport knives, scissors and general tools.
- **Fine** Ideal for honing a razor sharp edge on quality cutlery and woodworking tools that are regularly maintained.
- **Extra-Fine** the ultimate edge refinement for the finest quality knives and woodworking tools. Recommended after edge has been sharpened on the grit.

4" DIAMOND WHETSTONE

ART. W4



In leather sheath



| Item | Grit sizing |
|------|-------------|
| W4E | Extra-fine |
| W4F | Fine |
| W4C | Coarse |
| W4X | X-Coarse |



4" DIAMOND WHETSTONE

ART. A4

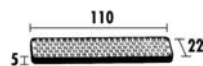

In plastic package



| Item | Grit sizing |
|------|-------------|
| A4E | Extra-fine |
| A4F | Fine |
| A4C | Coarse |
| A4X | X-Coarse |

MACHINIST POCKET WHETSTONE

ART. WM



- In leather sheath
 - Ideal for resharpening small size tools



| Item | Grit sizing |
|------|-------------|
| WMF | Fine |
| WMC | Coarse |

MACHINIST POCKET WHETSTONE

ART. WS7

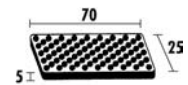
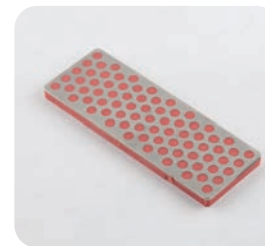

In plastic package



| Item | Grit sizing |
|------|-------------|
| WS7E | Extra-fine |
| WS7F | Fine |
| WS7C | Coarse |
| WS7X | X-Coarse |



MACHINIST POCKET WHETSTONE

ART. F70

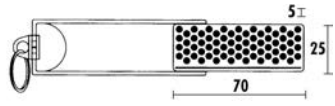

In plastic package



| Item | Grit sizing |
|------|-------------|
| F70F | Fine |
| F70C | Coarse |



DIAFOLD DIAMOND WHETSTONE

ART. FW

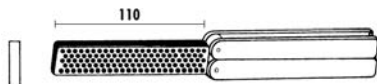
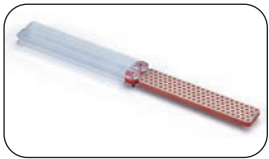

Diafold sharpeners with folding plastic handles



| Item | Grit sizing |
|------|-------------|
| FWE | Extra-fine |
| FWF | Fine |
| FWC | Coarse |
| FWX | X-Coarse |

| | |
|------|-----------------|
| FWEF | Ex.-fine/fine |
| FWFC | Fine/Coarse |
| FWCX | Coarse/X-Coarse |



DIAFOLD DIAMOND FLAT FILE

ART. FF

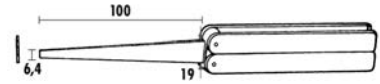

Pocket diafold diamond flat file



| Item | Grit sizing |
|------|-------------|
| FFF | Fine |
| FFC | Coarse |

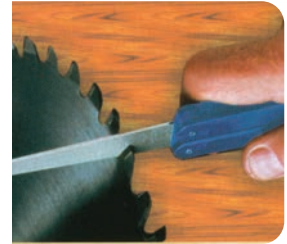

DIAFOLD SERRATED KNIFE SHARPENER

ART. FSK

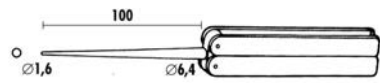
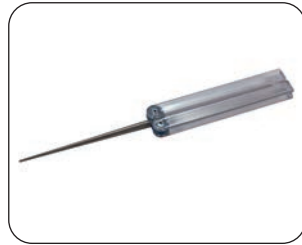

Pocket diafold conical diamond file



| Item | Grit sizing |
|------|-------------|
| FSKF | Fine |
| FSKC | Coarse |



6"/8"/12" DIAMOND WHETSTONE

ART. W6 - W8 - WT

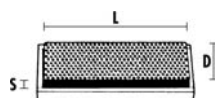

Bench model in hardwood case

| Item | Grit sizing | L | D | S |
|------|-------------|-----|----|----|
| W6E | Extra-fine | 152 | 51 | 19 |
| W6F | Fine | 152 | 51 | 19 |
| W6C | Coarse | 152 | 51 | 19 |
| W6X | X-Coarse | 152 | 51 | 19 |
| W8E | Extra-fine | 205 | 67 | 32 |
| W8F | Fine | 205 | 67 | 32 |
| W8C | Coarse | 205 | 67 | 32 |
| W8X | X-Coarse | 205 | 67 | 32 |
| WTF | Fine | 305 | 67 | 32 |

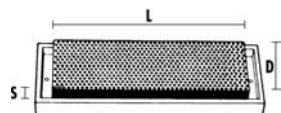
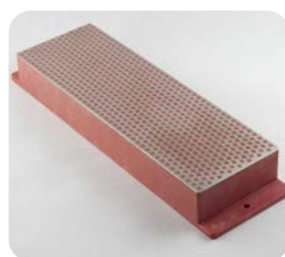

Bench model in plastic case

| Item | Grit sizing | L | D | S |
|-------|-------------|-----|----|----|
| W6EP | Extra-fine | 152 | 51 | 19 |
| W6FP | Fine | 152 | 51 | 19 |
| W6CP | Coarse | 152 | 51 | 19 |
| W6XP | X-Coarse | 152 | 51 | 19 |
| W8ENB | Extra-fine | 205 | 67 | 32 |
| W8FNB | Fine | 205 | 67 | 32 |
| W8CNB | Coarse | 205 | 67 | 32 |
| W8XNB | X-Coarse | 205 | 67 | 32 |



DEMO-STAND

ART. PDW6



- Demo stand including a diamond whetstone
- Supplied free of charge when ordering **two pieces** each of the following items

ART. F70F
ART. F70C



ART. W6F
ART. W6C



ART. W4F
ART. W4C



ART. FWF
ART. FWC



| Item | Grit sizing | Dimensions |
|-------|-------------|------------|
| PDW6F | Fine | 152x51x19 |
| PDW6C | Coarse | 152x51x19 |

NEW DEALER STARTER KITS

| Pcs | Item |
|-----|-------|
| 1 | PDW6C |
| 2 | W6FP |
| 2 | W6CP |
| 2 | F70F |
| 2 | F70C |
| 2 | FWE |
| 2 | FWF |
| 2 | FWC |
| 2 | FSKC |

DIAMOND WAVE SHARPENERS FOR RADIUS CUTTERS

ART. WAVF

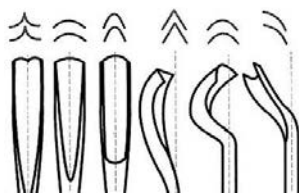
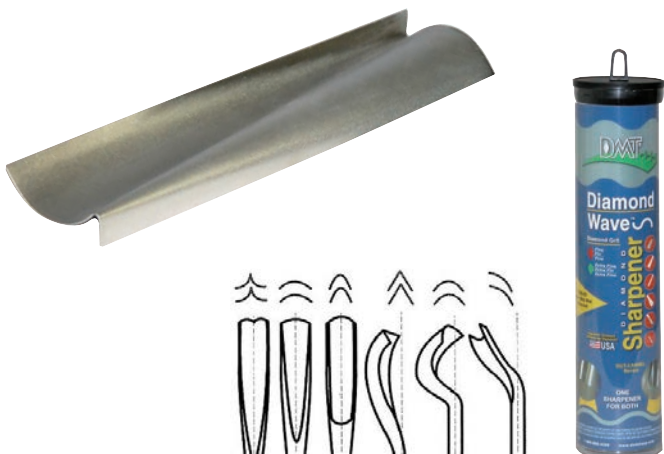

- **DIAMOND WAVE**
- Ideal for resharpening curved tools, like gouges, carving and wood turning tools
- Convex and concave diamond surface in one sharpening tool
- Resharpen tools with radius from min. 1,6 to max. 25 mm.
- Including anti-slippery pad for easier use
- No oil is needed – sharpen dry or with water



| Item | Grit sizing | Dimensions |
|------|-------------|------------|
| WAVF | Fine | 30x250x25 |

8" DIAMOND WHETSTONE WITH BASE

ART. WM8FC-WB



- **DUOSHARP**
- Double-sided stone:
 - **Coarse grit** to quickly restore a neglected edge
 - **Fine grit** for a razor sharp edge
- Ideal for all craftsmen who need to resharpen straight cutting edges
- Can resharpen a wide range of materials: carbide, steel, ceramic, glas, stone
- Supplied with plastic base



| Item | Grit sizing | Dimensions |
|----------|-------------|------------|
| WM8FC-WB | Coarse/Fine | 203x66 mm |

Spare parts

| | | |
|-------|-------------|-----------|
| WM8FC | Coarse/Fine | 203x66 mm |
|-------|-------------|-----------|



NEW DIAMOND SHARPENERS "ECONOMY LINE"



Sharpens, hones & laps: knives, router bits, plane blades, ski edges, fish hooks, garden tools, chisels, scissors, sawblades, lapidary, ceramics, broadheads, climbing equipment, masonry drills, axes, engraving tools, farm tools, mold & dies, planer/jointer knives, speed skates, carbide, glass.



- COARSE (C) - 45 micron**
General use-rapidly restores a dull edge on a tool or knife
- FINE (F) - 25 micron**
Restores a razor edge on well maintained tools and knives
- Ex-FINE (E) - 9 micron**
The ultimate edge refinement after stock removal on coarser diamond

DIAMOND WHETSTONE

ART. D4



In plastic package



| Item | Grit sizing | Dimensions |
|------|-------------|------------|
| D4E | Extra-fine | 110x22x5 |
| D4F | Fine | 110x22x5 |
| D4C | Coarse | 110x22x5 |

DIAMOND WHETSTONE

ART. D6



In plastic package



| Item | Grit sizing | Dimensions |
|------|-------------|------------|
| D6E | Extra-fine | 150x50x6 |
| D6F | Fine | 150x50x6 |
| D6C | Coarse | 150x50x6 |

GRINDING WHEELS



As a result of long experience in the production of special, high precision tools, **SISTEMI** has developed the Super Diamond **Klein**, which allows performing quicker and more economically efficient abrasive machining operations. Obtained by a process of synthesis to very high pressure and temperature, the diamond used in the grinding wheels **Klein** is artificial and has been tested to provide the best possible result on the machines for regrinding tools for woodworking, while for ferrous materials, such as tools in HSS, CBN (Cubic boron nitride) is used.

The choice of grain size plays also an important role and **SISTEMI** has decided to limit the amount of grains available in its program by choosing those with the best performance of most use.

The grains of diamond or CBN are agglomerated with different binders, classified according to the following characteristics:

- Capacity of particle retention
- Capacity of discharging worn grains
- Dressing capacity
- Thermal resistance
- Thermal conductivity
- Type of material to be processed

The attention to component selection and manufacturing process ensures that **Klein** grinding wheels are products of high precision. Mounting flanges, back-plates or adapters must be absolutely used and kept in good condition. All possible defects in the wheel-arbor coupling must be corrected before starting the wheel.

Furthermore it is important to remember that the use of coolant increases the cutting performance of the grinding wheels, reducing friction, heat generation and jamming of the abrasive surface.

Our Super Diamond **Klein** can be supplied in different shapes or dimensions on request, as well as in other grain sizes or bond types.

GRINDING WHEEL FOR ROUNDED SPURS DOWEL DRILLS

ART. X900

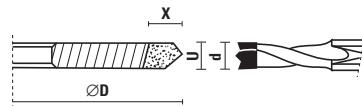

- **Type 1A1 SPECIAL**
- **Abrasive material**
- **Grain size D91**
- Suitable for Art. L114 - L115 - L116 - L117

| Item | Tool diam. | ØD | Bore | U | X |
|----------------|------------|-----|------|-----|---|
| X900.125.05D91 | 3÷7 | 125 | 20 | 5,5 | 8 |
| X900.125.07D91 | 8÷10 | 125 | 20 | 7 | 8 |

GRINDING WHEEL FOR DOWEL DRILLS

ART. X901

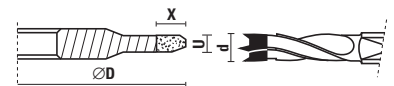
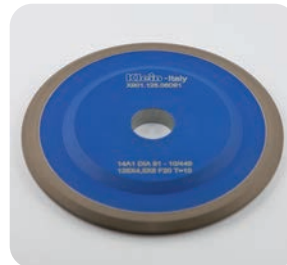

- **Type 14A1 SPECIAL**
- **Abrasive material**
- **Grain size D91**
- Suitable for Art. L101 - L102 - L103 - L104 - L105 - L106 - L107 - L108 - L109 - L110

| Item | Tool diam. | ØD | Bore | U | X |
|----------------|------------|-----|------|-----|---|
| X901.125.04D91 | 4 | 125 | 20 | 4 | 8 |
| X901.125.05D91 | 5 | 125 | 20 | 4,5 | 8 |
| X901.125.06D91 | 6 | 125 | 20 | 4,5 | 8 |
| X901.125.08D91 | 8 | 125 | 20 | 5 | 8 |
| X901.125.10D91 | 10 | 125 | 20 | 6 | 8 |

HIGH PERFORMANCE CUTTING DISC

ART. X902

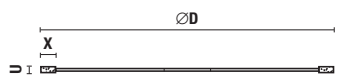

- Type 1A1R
- Abrasive material
- Grain size D181

| Item | ØD | Bore | U | X |
|-----------------|-----|------|-----|---|
| X902.125.12D181 | 125 | 20 | 1,2 | 6 |
| X902.150.12D181 | 150 | 20 | 1,2 | 6 |

GRINDING WHEEL FOR HOLLOW PARTS AND HOLES

ART. X903

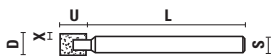

- Type 1A1W
- Abrasive material
- Grain size D126

| Item | D | U | X | S | L |
|-----------------|----|---|-----|---|----|
| X903.006.06D126 | 6 | 6 | 1,5 | 6 | 60 |
| X903.008.06D126 | 8 | 6 | 2 | 6 | 60 |
| X903.010.06D126 | 10 | 6 | 2 | 6 | 60 |
| X903.012.06D126 | 12 | 6 | 2 | 6 | 60 |

GENERAL PURPOSE STRAIGHT WHEEL

ART. X904

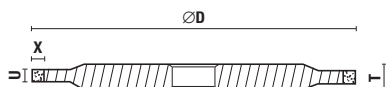
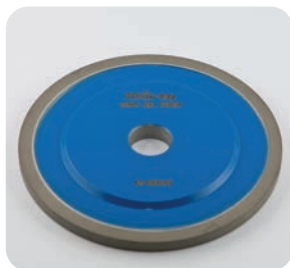

- Type 14A1
- Abrasive material
- Grain size D91

| Item | ØD | Bore | U | X | T |
|----------------|-----|------|---|---|----|
| X904.075.46D91 | 75 | 20 | 4 | 6 | 8 |
| X904.075.66D91 | 75 | 20 | 6 | 6 | 10 |
| X904.075.86D91 | 75 | 20 | 8 | 6 | 12 |
| X904.100.46D91 | 100 | 20 | 4 | 6 | 8 |
| X904.100.66D91 | 100 | 20 | 6 | 6 | 10 |
| X904.100.86D91 | 100 | 20 | 8 | 6 | 12 |
| X904.125.66D91 | 125 | 20 | 6 | 6 | 10 |
| X904.125.86D91 | 125 | 20 | 8 | 6 | 12 |

GENERAL PURPOSE STRAIGHT WHEEL

ART. X905

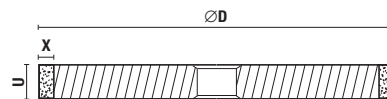

- Type 1A1
- Abrasive material
- Grain size D91

| Item | ØD | Bore | U | X |
|----------------|-----|------|----|---|
| X905.125.10D91 | 125 | 20 | 10 | 6 |
| X905.125.12D91 | 125 | 20 | 12 | 6 |

GRINDING WHEEL FOR HW TIPPED CUTTERS

ART. X920

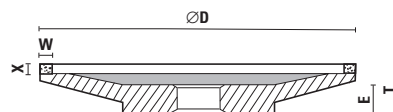

- Type 12A2 20°
- Abrasive material
- Grain size D64

| Item | ØD | Bore | W | X | T | E |
|----------------|-----|------|---|---|----|---|
| X920.150.46D64 | 150 | 20 | 6 | 4 | 21 | 9 |

GRINDING WHEEL FOR PLANER KNIVES

ART. X921

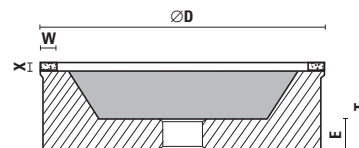

- Type 6A2
- D91 diamond type for HW knives
- Carborundum (CBN) B151 for HS knives

| Item | ØD | Bore | W | X | T | E | Grain size | Abrasive |
|-----------------|-----|------|---|---|----|----|------------|----------|
| X921.125.45D91 | 125 | 16 | 5 | 4 | 40 | 16 | D91 | DIA |
| X921.150.46D91 | 150 | 20 | 6 | 4 | 49 | 15 | D91 | DIA |
| X921.175.56D91 | 175 | 20 | 6 | 5 | 56 | 15 | D91 | DIA |
| X921.125.45B151 | 125 | 16 | 5 | 4 | 40 | 16 | B151 | CBN |
| X921.150.46B151 | 150 | 20 | 6 | 4 | 49 | 15 | B151 | CBN |

GRINDING WHEEL FOR ROUTER CUTTERS

ART. X922

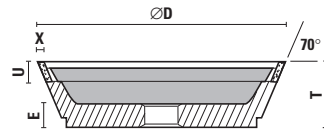

- Type 11V9
- Abrasive material
- Grain size D126
- For tool top and diameter regrinding
- For both HW straight router bits and solid carbide spiral router bits

| Item | ØD | Bore | U | X | T | E |
|-----------------|-----|------|----|---|----|----|
| X922.075.13D126 | 75 | 20 | 10 | 3 | 30 | 11 |
| X922.100.13D126 | 100 | 20 | 10 | 3 | 33 | 12 |

GRINDING WHEEL FOR ROUTER CUTTERS

ART. X923

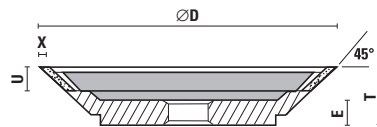

- Type 12V9 45°
- Abrasive material
- Grain size D126
- For tool face grinding on solid carbide spiral router cutters

| Item | ØD | Bore | U | X | T | E |
|-----------------|-----|------|----|---|----|----|
| X923.075.13D126 | 75 | 20 | 10 | 3 | 20 | 10 |
| X923.100.13D126 | 100 | 20 | 10 | 3 | 25 | 11 |
| X923.125.13D126 | 125 | 20 | 10 | 3 | 26 | 12 |

GRINDING WHEEL FOR HW TIPPED SAWBLADES

ART. X930

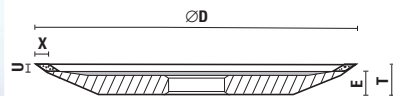

- Type 12V2
- Abrasive material
- Grain size D64
- Tooth face grinding
- Finishing grinding wheel

| Item | ØD | Bore | X | U | T | E | Machine type |
|----------------|-----|--------|---|---|----|----|--------------|
| X930.075.24D64 | 75 | 25 | 4 | 2 | 10 | 8 | Grifo AC66 |
| X930.100.33D64 | 100 | 25 ch | 3 | 3 | 11 | 8 | Grifo AC90 |
| X930.125.33D64 | 125 | 25 ch | 3 | 3 | 12 | 8 | Vollmer |
| X930.126.33D64 | 125 | 32 | 3 | 3 | 12 | 8 | Vollmer CHC |
| X930.150.33D64 | 150 | 32 | 3 | 3 | 12 | 8 | Ake |
| X930.175.33D64 | 175 | 50,8+1 | 3 | 3 | 12 | 12 | Finimat |
| X930.200.33D64 | 200 | 32 | 3 | 3 | 12 | 11 | Vollmer CHP |

GRINDING WHEEL FOR HW TIPPED SAWBLADES

ART. X940

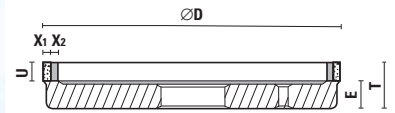

- Type 6AA9
- Abrasive material
- Grain size D126/46
- Tooth top grinding
- Double grain grinding wheel for single pass rough and finishing

| Item | ØD | U | X1+X2 | T | E | Bore | Machine type |
|-------------------|-----|---|---------|----|----|--------|-----------------|
| X940.075.62D12646 | 75 | 6 | 2,5+2,5 | 17 | 9 | 25 ch | Grifo AC66 |
| X940.100.82D12646 | 100 | 8 | 2,5+2,5 | 18 | 9 | 25 ch | Grifo AC90 |
| X940.125.82D12646 | 125 | 8 | 2,5+2,5 | 20 | 11 | 32 ch | Voll. CHC - CHP |
| X940.126.82D12646 | 125 | 8 | 2,5+2,5 | 20 | 11 | 50,8+1 | Finimat |

GRINDING WHEEL FOR BAND SAWBLADES

ART. X950

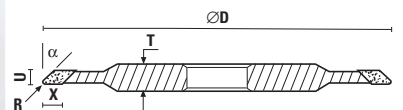

- Type 14VR
- Carborundum (CBN) grinding wheels
- Grain size B181
- For hardened steel and/or stellite

| Item | ØD | U | X | T | R | α | Bore |
|-----------------|-----|---|---|----|---|-----|------|
| X950.150.47B181 | 150 | 4 | 7 | 10 | 1 | 40° | 20 |

Measuring instruments

15

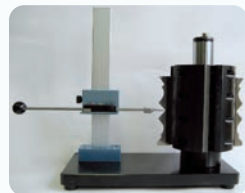

PRE SET P322
Pag. 15.03



THREE POINT DIGITAL CALIPER FOR CUTTERS Z=3
Page 15.03



PRE SET PERFORMANCE
Pag. 15.04 - 15.05



PRE SET LEADER PLUS
Pag. 15.06 - 15.07



PRE SET UNIKO
Pag. 15.08 - 15.09



PRE SET PRIME
Pag. 15.10 - 15.11



PRE SET P368
Pag. 15.12 - 15.13



ANGOLFAST
Page 15.14



GAUGE FOR LINEAR MEASUREMENTS
Page 15.15

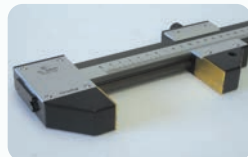

GAUGE FOR LINEAR MEASUREMENTS WITH STEEL PLATES
Page 15.15



GAUGE FOR DISTANCE BETWEEN HOLES
Page 15.16



GAUGE FOR 90° V-FOLD CUTS
Page 15.16

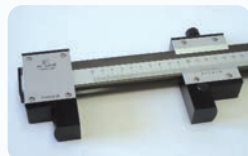

GAUGE FOR INSIDE/OUTSIDE MEASURING
Page 15.17

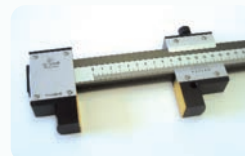

GAUGE FOR INSIDE/OUTSIDE MEASURING WITH STEEL PLATES
Page 15.17



GAUGE FOR LINEAR MEASUREMENTS AND DISTANCE BETWEEN CENTRES
Page 15.18





GAUGE FOR LINEAR MEASUREMENTS,
DISTANCE FROM THE CENTRES OF
THE HOLE TO THE EDGE OF THE PANEL
Page 15.18

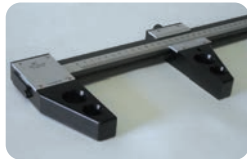

GAUGE FOR LINEAR MEASUREMENTS,
WITH LONG JAWS
Page 15.19



GAUGE FOR LINEAR MEASUREMENTS,
WITH LONG JAWS AND STEEL PLATES
Page 15.19



GAUGE FOR 45° CUTS
Page 15.20



GAUGE FOR DIAGONAL AND OUT
OF SQUARE MEASUREMENTS
Page 15.20



OPTICAL LENS
Page 15.21



GAUGE CASE
Page 15.21



CALIBRATION CERTIFICATE
Page 15.21



GAUGES FOR LINEAR
MEASUREMENTS
Page 15.22



GAUGES FOR LINEAR-INSIDE/OUTSIDE
MEASUREMENTS
Page 15.22



GAUGE FOR LINEAR, INSIDE/OUTSIDE,
DISTANCE BETWEEN HOLES, OUT OF
SQUARE ANGLES MEASUREMENTS
Page 15.23



GAUGE FOR 45° CUTS
Page 15.23



GAUGE FOR LINEAR, INSIDE/OUTSIDE,
DISTANCE BETWEEN HOLES, OUT OF
SQUARE ANGLES MEASUREMENTS
Page 15.24



GAUGE FOR LINEAR MEASUREMENTS,
WITH LONG JAWS AND STEEL PLATES
Page 15.25



GAUGE WITH NONIUS FOR
LINEAR-INSIDE/OUTSIDE
MEASUREMENTS WITH LONG JAWS
AND STEEL PLATES
Page 15.25



GAUGE WITH WIRELESS CONNECTION
FOR LINEAR MEASUREMENTS
Page 15.26



GAUGE WITH WIRELESS CONNECTION
FOR LINEAR, INSIDE/OUTSIDE,
DISTANCE BETWEEN HOLES,
OUT OF SQUARE ANGLES
MEASUREMENTS
Page 15.26



MAGNETIC STRIP MEASURING
SYSTEM
Page 15.27

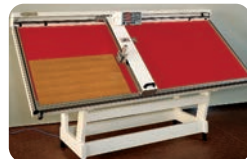

ELECTRONIC WORK STATION
Page 15.28 - 15.29

PRE SET P322

The radius measuring stand is a precision device of simple and quick use, suitable to measure the radius of profiled cutterheads. Before mounting the tools in a machine it is absolutely important to know the correct dimensions of the cutter and set them in order to start the production without any additional concerns.

The **Preset P322** was designed and developed in collaboration with technicians who work daily with these type of tools, having troubles with setting operations. The result is an optimization of the production and a good saving of time.

The **Preset P322** is the best accessory beside a moulding or a CNC machine.

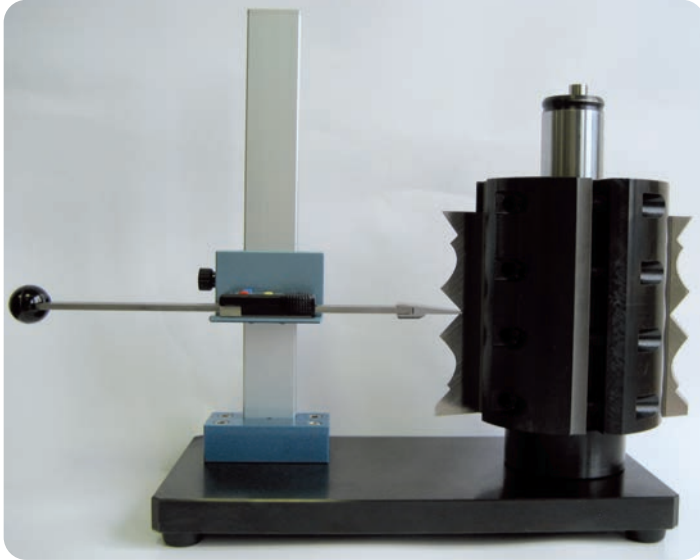

Main features
 Arbor height: 230 mm
 R max (cutterhead radius): 120 mm

Digital readout:
 Resolution: 0,01 mm
 Readout in mm/inches
 Battery-power (SR44)
 Operating temperature range: 0/+40°
 Storage temperature range: -10/+60°
 Umidity: ≤ 80%

| Item | Ø Arbor | Height | R max |
|-----------------|-----------|--------|-------|
| PRE-SET P322/30 | 30 | 230 | 120 |
| PRE-SET P322/35 | 35 | 230 | 120 |
| PRE-SET P322/40 | 40 | 230 | 120 |
| PRE-SET P322/32 | 1" 1/4" | 230 | 120 |
| PRE-SET P322/38 | 1" 1/2" | 230 | 120 |
| PRE-SET P322/46 | 1" 13/16" | 230 | 120 |

THREE POINT DIGITAL CALIPER FOR CUTTERS Z=3

ART. C.DIGIT.Z3

Caliper for measuring the diameter of router bits with three cutting edges (our items T143/T144, T153/T154 and any cutter Z=3)

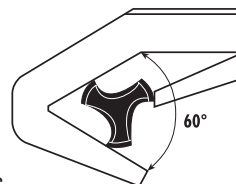

- Measuring range: 4 mm ÷ 40,00 mm / 0,16" ÷ 1,73"
- Resolution: 0,01 mm/0,0005"
- Accuracy: ± 0,05 mm/± 0,002"
- Repeatability: 0,01 mm/0,0005"
- Maximum measurement speed: 1,5 m/s - 60 in/s

- Operating temperature: 0°C÷40°C
- Storage temperature: -10°C÷60°C
- Power: 1,5V SR44 (silver oxide cell) - 1 battery
- Battery life: 1 year continuous usage/
3 years under normal operation

| Item | Measuring range |
|------------|-----------------|
| C.DIGIT.Z3 | 4÷40 mm |

PRE SET PERFORMANCE

The m. conti has been producing presetters for over 30 years. This experience has allowed to understand the importance of ease of use and ergonomics. In m. conti these important factors are held in great importance when designing presetters. Everything is within reach and easy to handle. Designed and developed in the field of tooling manufacture, the **preset PERFORMANCE** are also essential in sharpening centers and production units of furniture or windows, for checking the condition of the tools and their settings before being mounted in the machine.

| Item | Measuring range |
|-----------------------------------|---------------------|
| PRE-SET PERFORMANCE 44 NEW | H 400 mm - Ø 400 mm |
| PRE-SET PERFORMANCE 45 NEW | H 500 mm - Ø 400 mm |
| PRE-SET PERFORMANCE 46 NEW | H 600 mm - Ø 400 mm |
| PRE-SET PERFORMANCE 65 NEW | H 500 mm - Ø 600 mm |
| PRE-SET PERFORMANCE 66 NEW | H 600 mm - Ø 600 mm |
| PRE-SET PERFORMANCE 68 NEW | H 800 mm - Ø 600 mm |



AXIS Z: Oversize, heavy duty, steel column. Thermally stabilized. SP class precision linear guide and preloaded with recirculating bearings. Linearity of movement is guaranteed by **1 guide with four-row linear recirculating ball bearing** with preloaded slides. It is equipped with glass optical scale with **micrometric resolution (0,001)** and supplied with their inspection certificate.

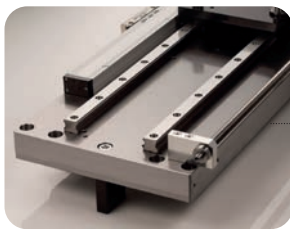

AXIS X: Stabilized steel plate, ground to a ± 2 planarity. Guides are directly fixed to the steel base of the presetter to guarantee constant geometry alignment. Linearity of movement is guaranteed by **2 parallel guides with four-row linear recirculating ball bearing** with preloaded slides. Guides are directly fixed to the steel base of the presetter to guarantee constant geometry alignment. It is equipped with glass optical scale with **micrometric resolution (0,001)** and supplied with their inspection certificate.



Monitor full HD 24"

Interchangeable tool sleeves are made in tempered steel with high precision (internal cone run-out $\pm 2\mu$). **Calibration spheres** integrated in the tool sleeve for fast and precise zero setting.



I - TECH SOFTWARE C.V.S. - FULL (Conti Vision System)
Software is the interface between the presetter and the user. The software is based on a high performance PC with last generation Windows® operating system.



| Model | Dimensions | Weight | Power |
|-------|------------------------|--------|--------------------------|
| 44 | A 1167-P 600-H 1757 mm | 260 kg | 230 V (optional 110V) |
| 45 | A 1167-P 600-H 1857 mm | 265 kg | |
| 46 | A 1167-P 600-H 1957 mm | 270 kg | |
| 65 | A 1267-P 600-H 1857 mm | 295 kg | |
| 66 | A 1267-P 600-H 1957 mm | 300 kg | |
| 68 | A 1267-P 600-H 1957 mm | 310 kg | |

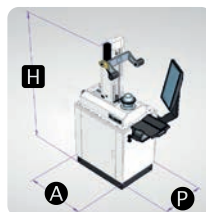

CRATE



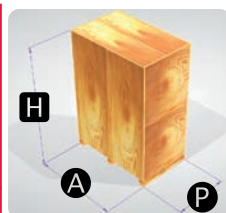









| Model | Dimensions | Weight |
|-------|------------------------|--------|
| 44 | A 1420-P 880-H 2000 mm | 350 kg |
| 45 | A 1420-P 880-H 2100 mm | 355 kg |
| 46 | A 1420-P 880-H 2200 mm | 365 kg |
| 65 | A 1520-P 880-H 2100 mm | 390 kg |
| 66 | A 1520-P 880-H 2200 mm | 395 kg |
| 68 | A 1520-P 880-H 2200 mm | 405 kg |

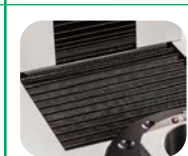

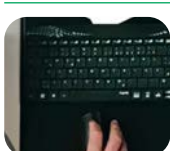

SPARE CONE-HOLDERS

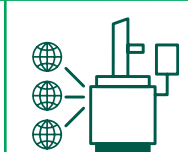
| Item | Description |
|---------------------|---|
| PRE-SET BL.ISO 30 | for tool holders ISO 30 |
| PRE-SET BL.ISO 40 | for tool holders ISO 40 |
| PRE-SET BL.ISO 50 | for tool holders ISO 50 |
| PRE-SET BL.HSK 63F | for tool holders HSK 63F/D/B |
| PRE-SET BL.HSK 63A | for tool holders HSK 63A/C/E |
| PRE-SET BL.HSK 80A | for tool holders HSK 80 |
| PRE-SET BL.30x130 | with arbor L=130, for tools with bore d= 30 |
| PRE-SET BL.30x300 | with arbor L=300, for tools with bore d= 30 |
| PRE-SET BL.35x130 | with arbor L=130, for tools with bore d= 35 |
| PRE-SET BL.35x300 | with arbor L=300, for tools with bore d= 35 |
| PRE-SET BL.40x130 | with arbor L=130, for tools with bore d= 40 |
| PRE-SET BL.40x300 | with arbor L=300, for tools with bore d= 40 |
| PRE-SET BL.50x130 | with arbor L=130, for tools with bore d= 50 |
| PRE-SET BL.50x300 | with arbor L=300, for tools with bore d= 50 |
| PRE-SET BL.HS.HSK63 | Cone holder for mechanical locking |

PRODUCT FEATURES

| | | |
|---|--|--|
|  <p>The PERFORMANCE range is equipped, as a standard, with Interlock System. The system is flexible and can be used with the vast majority of standard pull studs. Tool sleeve rotation brake is also a standard feature.</p> |  <p>Pneumatic axis movement allows fast and precise positioning of the camera thanks to a button on the ergonomic handle.</p> |  <p>Two manual wheels allows micrometric movement of both Z and X axis for best precision and accuracy.</p> |
|  <p>Camera is a high-resolution CMOS camera with telecentric lenses. It offers a field of view of 7x7 mm (0,27"x0,27") in both Profile View and Real View mode and 40x enlargement.</p> |  <p>High Performance dust guards maintain the presetter guides and sliders in perfect shape at all times. The presetter can work in difficult conditions.</p> |  <p>LED ring cold light for the frontal illumination of tool surface. Light intensity regulation is possible.</p> |
|  <p>A height adjustable support tray holds the wireless mouse and keyboard becoming an efficient work station.</p> |  <p>A label printer supplied in order to print relevant tool data.</p> |  <p>PC with last generation Microsoft® operating system. Data saved to SSD hard drive.</p> |
|  <p>LAN connection to transfer data through a company network directly to machine tools.</p> |  <p>Connection to other tool data transmission systems such as BALLUFF® is also possible as well as Teleservice diagnostics.</p> |  <p>A big service cabinet has been created below the Preset. Easy to access it is an easy way to have equipment protected but all within reach.</p> |

OPTIONAL

| | |
|--|--|
|  <p>Item PRE-SET BL.HS.HSK63 Cone holder HSK63 for mechanical locking with Interlock System.</p> |  <p>Item PRESET 105 22" touch screen (To be included at the time of order and replace the standard)</p> |
|--|--|

SOFTWARE - CONTI VISION SYSTEM

ALL DATA IN ONE VIEW

Simple, multi-language and intuitive the CONTI VISION SYSTEM software is easy for everyone. All functions are visualized, with easy to understand icons. It is possible to create up to 200 machine origins and memorize 200 tools for each machine. The tool measuring interface works like a real CAD and **any tool measure can be acquired**. The new **DXF function** allows the user to compare tool profiles against imported files or to scan and acquire a tool geometry. The new **GHOST function** permits to measure the maximum diameter and profile simply rotating the tool. **Real view tool inspection mode** clear, 40x enlargement, view of tool surface.

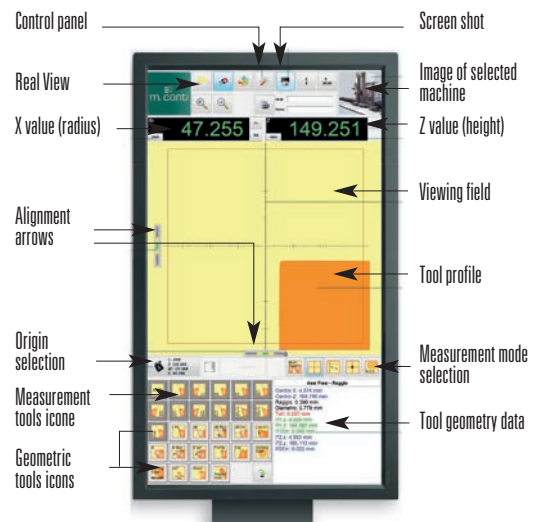
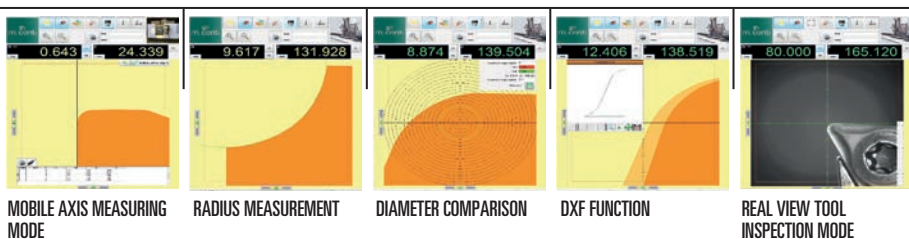

CONNECTIVITY

LAN connection to transfer data through a company network directly to machine tools. Connection to other tool data transmission systems such as BALLUFF® is also possible as well as Teleservice diagnostics.

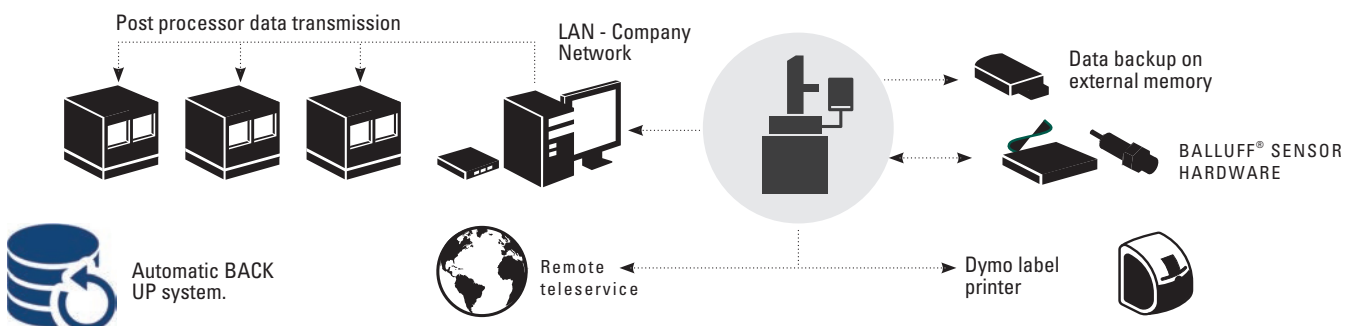

PRE SET LEADER PLUS

Preset LEADER Plus are high precision instruments performing high technology operations. Their structure is guaranteed by best quality components along with an interface very simple and intuitive to use. Designed and developed in the field of tooling manufacture, the **preset LEADER Plus** are also essential in sharpening centers and production units of furniture or windows, for checking the condition of the tools and their settings before being mounted in the machine. In recent years the family of the **preset LEADER Plus** has increased thanks to additional models with new combinations of diameter and height, satisfying most of the needs of market operators.



The **structure** is entirely made in steel and ensures greater strength and hardness as well as extreme size accuracy and straightness. It is normalized for improved strength and dimensional stability in time.

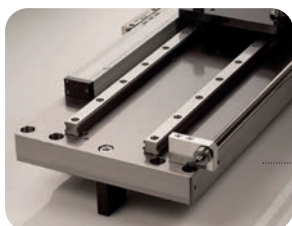

Linearity of movement is guaranteed by **2 parallel linear guides on the X Axis** with four-row linear recirculating ball bearing with preloaded slides. **1 guide is used on the Z axis.** Guides are directly fixed to the steel base of the presetter to guarantee constant geometry alignment. Both X and Z axis are equipped with glass optical scales with a resolution (0,001) and supplied with their inspection certificate

| Item | Measuring range |
|-----------------------------------|---------------------|
| PRE-SET LEADER Plus 44 NEW | H 400 mm - Ø 400 mm |
| PRE-SET LEADER Plus 45 NEW | H 500 mm - Ø 400 mm |



Monitor full HD da 22"

Interchangeable tool sleeves are made in tempered steel with high precision (internal cone run-out $\pm 2\mu$). **Calibration spheres integrated** in the tool sleeve for fast and precise zero setting.



SPARE CONE-HOLDERS

| Item | Description |
|---------------------|---|
| PRE-SET BL.ISO 30 | for tool holders ISO 30 |
| PRE-SET BL.ISO 40 | for tool holders ISO 40 |
| PRE-SET BL.ISO 50 | for tool holders ISO 50 |
| PRE-SET BL.HSK 63F | for tool holders HSK 63F/D/B |
| PRE-SET BL.HSK 63A | for tool holders HSK 63A/C/E |
| PRE-SET BL.HSK 80A | for tool holders HSK 80 |
| PRE-SET BL.30x130 | with arbor L=130, for tools with bore d= 30 |
| PRE-SET BL.30x300 | with arbor L=300, for tools with bore d= 30 |
| PRE-SET BL.35x130 | with arbor L=130, for tools with bore d= 35 |
| PRE-SET BL.35x300 | with arbor L=300, for tools with bore d= 35 |
| PRE-SET BL.40x130 | with arbor L=130, for tools with bore d= 40 |
| PRE-SET BL.40x300 | with arbor L=300, for tools with bore d= 40 |
| PRE-SET BL.50x130 | with arbor L=130, for tools with bore d= 50 |
| PRE-SET BL.50x300 | with arbor L=300, for tools with bore d= 50 |
| PRE-SET BL.HS.HSK63 | Cone holder for mechanical locking |

| Leader Plus | Dimensions | Weight | Power |
|-------------|------------------------|--------|-----------------|
| 44 | A 1080-P 626-H 950 mm | 136 kg | 230 V |
| 45 | A 1080-P 626-H 1050 mm | 142 kg | (optional 110V) |

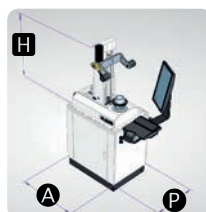

CRATE

| Leader Plus | Dimensions | Weight |
|-------------|------------------------|--------|
| 44 | A 1180-P 820-H 1210 mm | 182 kg |
| 45 | A 1180-P 820-H 1310 mm | 189 kg |

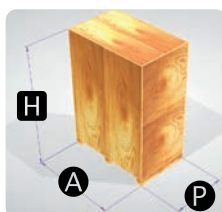

PRODUCT FEATURES



Camera is a high-resolution C-MOS camera with telecentric lenses. It offers a **field of view of 7x7 mm (0,27"x0,27")** in both Profile View and Real View mode and 40x enlargement.



Pneumatic axis movement allows fast and precise positioning of the camera thanks to a button on the ergonomic handle, whereas two manual wheels allow **micrometric movement** of both Z and X axis for best precision and accuracy.



Cold light LED ring illuminator. Light intensity regulation is possible.

OPTIONAL

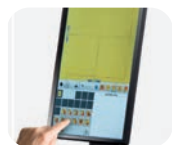

Item **PRESET 105**
22" touch screen
(To be included at the time of order and replace the standard).



Item **PRESET 099**
Holding cart,
dimensions 810x560xH720 cm



Item **PRESET 103**
Labor printer Dymo 450

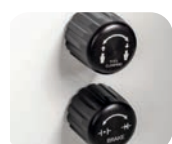

Item **PRESET 101**
Interlock System
(no ISO 30)

Item **PRESET 102**
Interlock retaining pawls



Item **PRE-SET BL.HS.HSK63**
Cone holder HSK63 for
mechanical locking with
Interlock System.

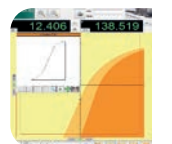

Item **PRESET 100**
DXF Software
Allow to import/export create
and compare a DXF drawing.

SOFTWARE - CONTI VISION SYSTEM

ALL DATA IN ONE VIEW

Simple, multi-language and intuitive the CONTI VISION SYSTEM software is easy for everyone. All functions are visualized, with easy to understand icons. It is possible to create up to 200 machine origins and memorize 200 tools for each machine. The tool measuring interface works like a real CAD and **any tool measure can be acquired**. The new **DXF function (optional)** allows the user to compare tool profiles against imported files or to scan and acquire a tool geometry. The new **GHOST function** permits to measure the maximum diameter and profile simply rotating the tool. **Real view tool inspection mode** clear, 40x enlargement, view of tool surface.

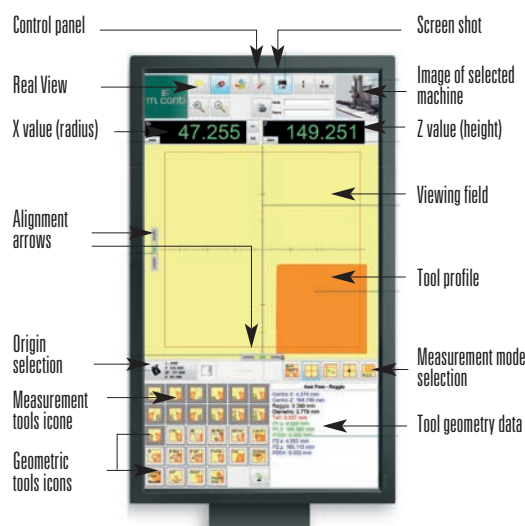
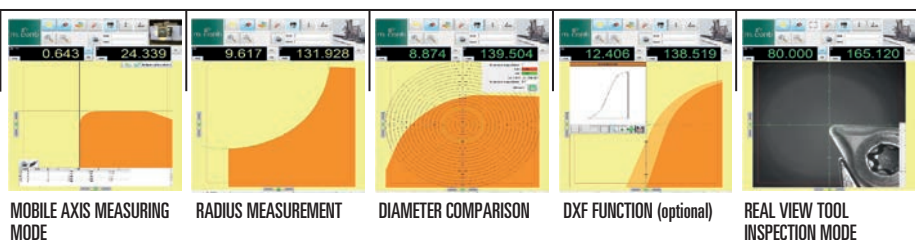

CONNECTIVITY

LAN tools connectivity to company network for tool data transmission using Post Processor. Possibility of TELESERVICE. Connection to other data transmission systems, such as BALLUFF® (optional) for example, is also possible.

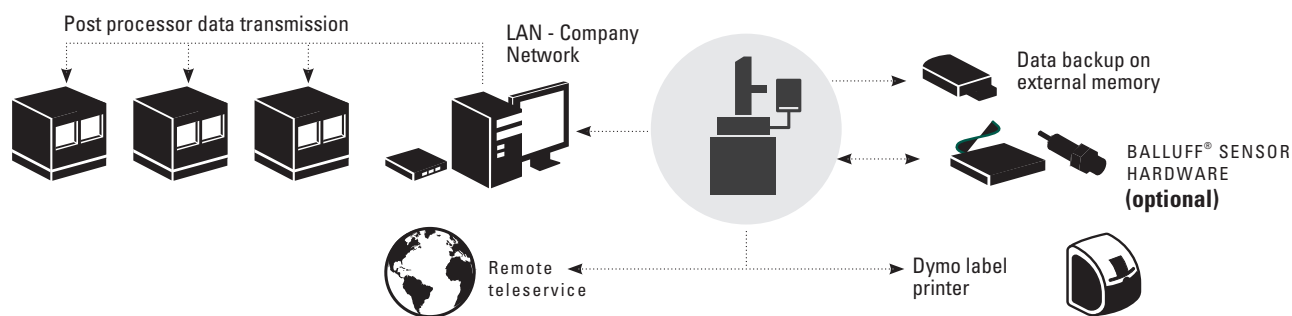

A project must also consider the customer's need for safety and easy of use. This is why our presetter are equipped with removable transport handles which make any necessary movement easy and safe.

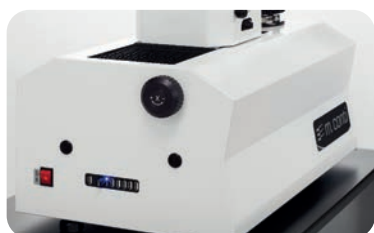

PRE SET UNIKO

Fully equipped, sturdy and extremely easy to use. Entering the world of camera presetting is easy with this user friendly presetter. Designed and developed in the field of tooling manufacture, the **preset UNIKO** are also essential in sharpening centers and production units of furniture or windows, for checking the condition of the tools and their settings before being mounted in the machine. Powerful Post Processor to easily integrate in any working condition.



The **structure** is entirely made in steel and ensures greater strength and hardness as well as extreme size accuracy and straightness. It is normalized for improved strength and dimensional stability in time.



Linearity of movement is guaranteed by **2 parallel linear guides on the X Axis** with four-row linear recirculating ball bearing with preloaded slides. **1 guide is used on the Z axis.** Guides are directly fixed to the steel base of the presetter to guarantee constant geometry alignment. Both X and Z axis are equipped with glass optical scales with a resolution (0,001) and supplied with their inspection certificate

| Item | Measuring range |
|-----------------------------|---------------------|
| PRE-SET UNIKO 44 NEW | H 400 mm - Ø 400 mm |
| PRE-SET UNIKO 45 NEW | H 500 mm - Ø 400 mm |



Interchangeable tool sleeves are made in tempered steel with high precision (internal cone run-out $\pm 2\mu$). **Calibration spheres** are integrated in the tool sleeve for fast and precise zero setting.



| Uniko | Dimensions | Weight | Power |
|-------|------------------------|--------|-----------------|
| 44 | A 1080-P 626-H 950 mm | 136 kg | 230 V |
| 45 | A 1080-P 626-H 1050 mm | 142 kg | (optional 110V) |

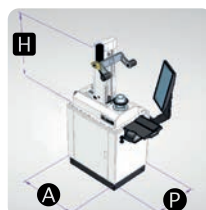

SPARE CONE-HOLDERS

| Item | Description |
|--------------------|---|
| PRE-SET BL.ISO 30 | for tool holders ISO 30 |
| PRE-SET BL.ISO 40 | for tool holders ISO 40 |
| PRE-SET BL.ISO 50 | for tool holders ISO 50 |
| PRE-SET BL.HSK 63F | for tool holders HSK 63F/D/B |
| PRE-SET BL.HSK 63A | for tool holders HSK 63A/C/E |
| PRE-SET BL.HSK 80A | for tool holders HSK 80 |
| PRE-SET BL.30x130 | with arbor L=130, for tools with bore d= 30 |
| PRE-SET BL.30x300 | with arbor L=300, for tools with bore d= 30 |
| PRE-SET BL.35x130 | with arbor L=130, for tools with bore d= 35 |
| PRE-SET BL.35x300 | with arbor L=300, for tools with bore d= 35 |
| PRE-SET BL.40x130 | with arbor L=130, for tools with bore d= 40 |
| PRE-SET BL.40x300 | with arbor L=300, for tools with bore d= 40 |
| PRE-SET BL.50x130 | with arbor L=130, for tools with bore d= 50 |
| PRE-SET BL.50x300 | with arbor L=300, for tools with bore d= 50 |

CRATE

| Uniko | Dimensions | Weight |
|-------|------------------------|--------|
| 44 | A 1180-P 820-H 1210 mm | 182 kg |
| 45 | A 1180-P 820-H 1310 mm | 189 kg |

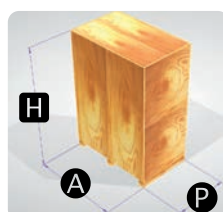

PRODUCT FEATURES



Camera is a high-resolution C-MOS camera with telecentric lenses. It offers a **field of view of 5x5mm** (0,20" x 0,20") in both Profile View and Real View mode and 40x enlargement.



Axis movement is manual and allows fast and precise positioning of the camera with two possibilities: fast movement and micrometric movement.



Two manual wheels allows **micrometric movement** of both Z and X axis for best precision and accuracy.

OPTIONAL



Item **PRESET 099**
Holding cart,
dimensions
810x560xH720 cm



Item **PRESET 103**
Laser printer
Dymo 450



Item **PRESET 104**
Cold light LED ring
illuminator.
Light intensity
regulation is
possible.

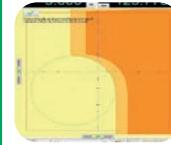

Item **PRESET 106**
Tool Pack
additional
software package

SOFTWARE - CONTI VISION SYSTEM

ALL DATA IN ONE VIEW

Simple, multi-language and intuitive the CONTI VISION SYSTEM software is easy for everyone. All functions are visualized, with easy to understand icons. It is possible to create up to 200 machine origins and memorize 200 tools for each machine. The tool measuring interface works like a real CAD and **any tool measure can be acquired**. The new **GHOST function available with our Tool Pack (optional)** permits to measure the maximum diameter and profile simply rotating the tool. **Real view tool inspection mode** clear, 40x enlargement, view of tool surface.

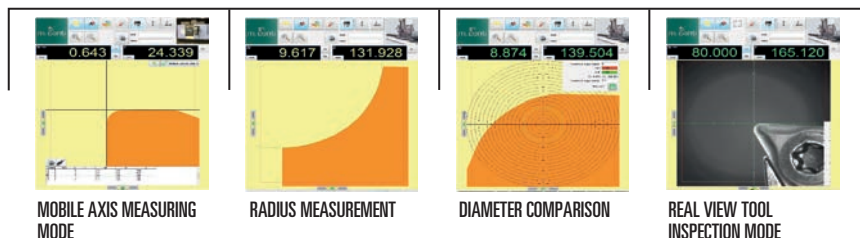
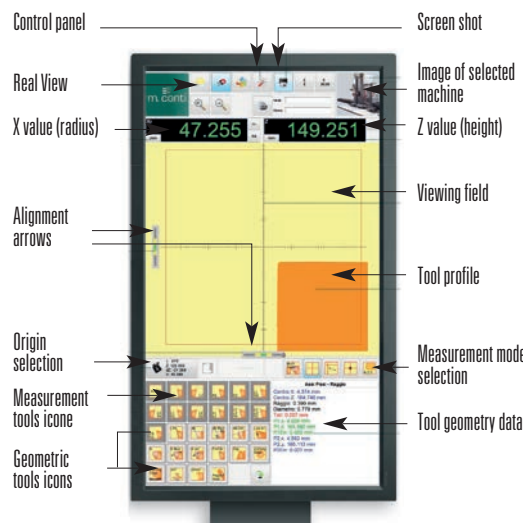

CONNECTIVITY

LAN connectivity to company network for tool data transmission using Post Processor.
Possibility of TELESERVICE.

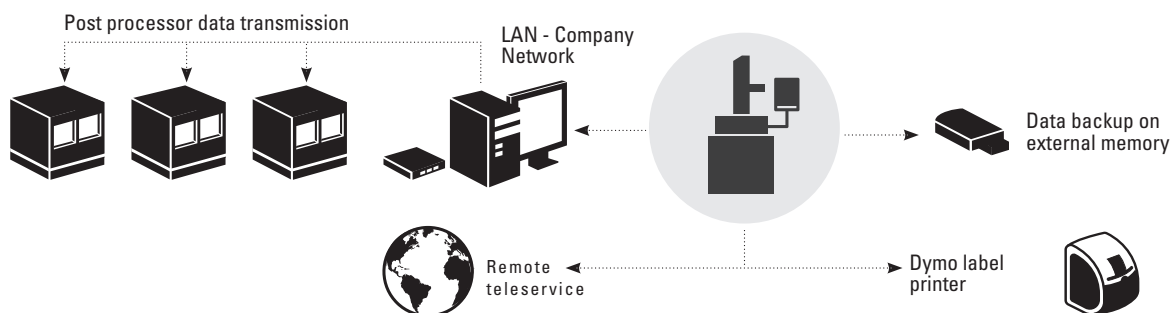

A project must also consider the customer's need for safety and easy of use. This is why our presetter are equipped with removable transport handles which make any necessary movement easy and safe.

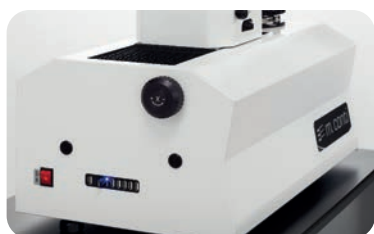

PRE SET PRIME

Fully equipped, sturdy and easy to use. The world of camera presetting is within reach with this user friendly presetter. Checking tool geometry is easy and intuitive.



The **structure** is entirely made in steel and ensures greater strength and hardness as well as extreme size accuracy and straightness. It is normalized for improved strength and dimensional stability in time.

| Item | Measuring range |
|--------------------------------|---------------------|
| PRE-SET PRIME 32/40 NEW | H 400 mm - Ø 320 mm |



Interchangeable tool sleeves with reference notch ISO-BT / HSK / CAPTO (no reference shafts required)

LCD Monitor 19"



| Prime | Dimensions | Weight | Power |
|-------|----------------------|--------|-------------|
| 32/40 | A 870-P 516-H 880 mm | 90 kg | 230 V/110V) |

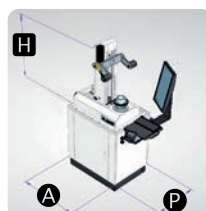

CRATE

| Prime | Dimensions | Weight |
|-------|------------------------|--------|
| 32/40 | A 1020-P 720-H 1080 mm | 131 kg |

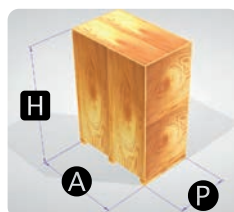

SPARE CONE-HOLDERS

| Item | Description |
|--------------------|---|
| PRE-SET BL.ISO 30 | for tool holders ISO 30 |
| PRE-SET BL.ISO 40 | for tool holders ISO 40 |
| PRE-SET BL.ISO 50 | for tool holders ISO 50 |
| PRE-SET BL.HSK 63F | for tool holders HSK 63F/D/B |
| PRE-SET BL.HSK 63A | for tool holders HSK 63A/C/E |
| PRE-SET BL.HSK 80A | for tool holders HSK 80 |
| PRE-SET BL.30x130 | with arbor L=130, for tools with bore d= 30 |
| PRE-SET BL.30x300 | with arbor L=300, for tools with bore d= 30 |
| PRE-SET BL.35x130 | with arbor L=130, for tools with bore d= 35 |
| PRE-SET BL.35x300 | with arbor L=300, for tools with bore d= 35 |
| PRE-SET BL.40x130 | with arbor L=130, for tools with bore d= 40 |
| PRE-SET BL.40x300 | with arbor L=300, for tools with bore d= 40 |
| PRE-SET BL.50x130 | with arbor L=130, for tools with bore d= 50 |
| PRE-SET BL.50x300 | with arbor L=300, for tools with bore d= 50 |

PRODUCT FEATURES



Camera is a high-resolution C-MOS camera with telecentric lenses. It offers a **field of view of 5x5mm** (0,20" x 0,20") in both Profile View and Real View mode and 40x enlargement.



Perfect balance of the support column allows smooth, effortless movement. The handle is comfortable and easy to grip. Manual axis movement.



LED lighting system for tool inspection.



Two big manual wheels allows micrometric movement of both Z and X axis for best precision and accuracy.

OPTIONAL



Item **PRESET 099.2**
Holding cart,
dimensions
810x560xH920 cm



Item **PRESET 103**
Label printer
Dymo 450

SOFTWARE - CONTI VISION SYSTEM

ALL DATA IN ONE VIEW

Simple, multi-language and intuitive the CONTI VISION SYSTEM software is easy for everyone. All functions are visualized, with easy to understand icons. Uploading a picture of a machine tool, creating up to 50 machine origins and memorizing 100 tools for each machine has never been so fast and easy. The tool measuring interface works like a real CAD and **any tool measure can be acquired**.

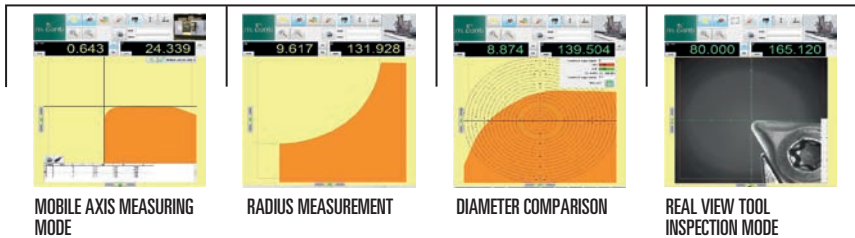
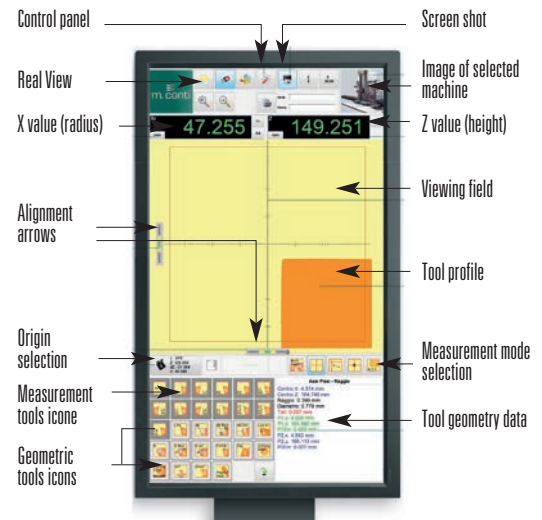

CONNECTIVITY

The Connectivity Pack (**optional**) is a powerful software with tool list compiling capabilities. A library of over 50 Post Processor allow the creation of CNC tool update files.

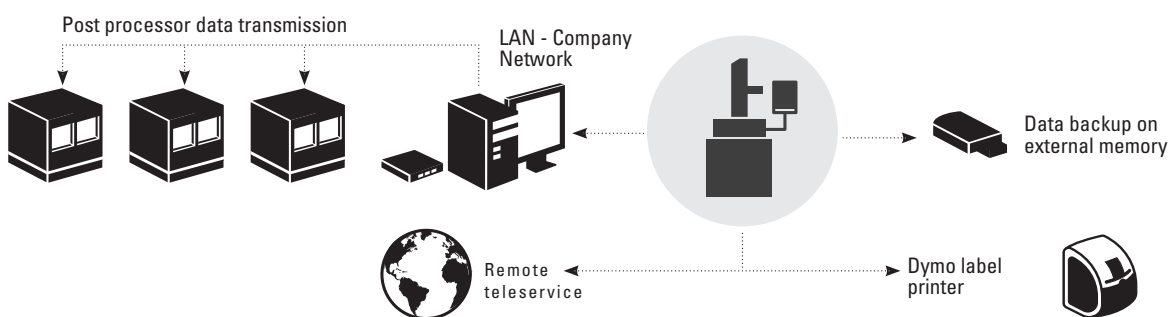

A project must also consider the customer's need for safety and easy of use. This is why our presetter are equipped with removable transport handles which make any necessary movement easy and safe.



PRE SET P368LR

The **Preset P368LR** is a precision tool setting instrument, easy and quick to use, especially designed to meet the requirements of the NC machine operators. It is mainly used in the wood, metal and glass working field where there is a constant need to set or adjust the tools. The **Preset P368LR** measures both the radius/diameter and the length/height of the tools. Working with different tool holders or various machines can be possible by setting up to 4 origins. The measures shown in the display can be set directly in the machine and the production quickly starts again.

| Item | Measuring range |
|-----------------------|---------------------|
| PRE-SET P368LR | H 300 mm - Ø 250 mm |
| PRE-SET P368LR/HSK63F | H 300 mm - Ø 250 mm |

Axis Z
Slide guide in anti-friction material.



Axis X
Preloaded recirculating ball-bearing guides.

No. 2 displays with big numbers are connected to the magnetic strips for measurements detection of axis X and Z.



Height measurement
The P368 is a very solid presetter designed to make tool height measurement very simple and always accurate.



Diameter measurement
The P368 has a solid base and provides smooth and accurate linear movements. The tool radius/diameter is always precise.

TECHNICAL FEATURES

- Excellent price/quality relationship
- Considerable cutback of tooling-up times, no waste of material
- 4 machine origins
- It measures all types of tools
- Battery powered – no need of electrical plug
- Large display easy to read
- One touch conversion mm/inch
- Interchangeable cone holders (ISO, HSK, VDI, arbors)

Measurement detection: Precision magnetic strip

Item
T. SFERA-P368

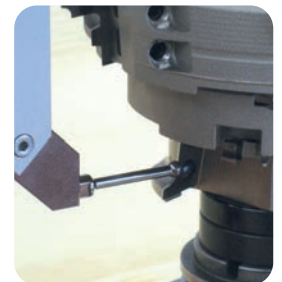

Spherical feeler for shaped cutters (Optional)



SPARE CONE-HOLDERS

The **preset P368LR** is supplied with a cone-holder (ISO30, ISO40, ISO50) on your choice. The **Preset P368LR/HSK63F** is supplied with an HSK63F cone holder included. Other cone-holders can also be purchased later.

| Item | Description |
|--------------------|---|
| PRE-SET BL.ISO 30 | for tool holders ISO 30 |
| PRE-SET BL.ISO 40 | for tool holders ISO 40 |
| PRE-SET BL.ISO 50 | for tool holders ISO 50 |
| PRE-SET BL.HSK 63F | for tool holders HSK 63F/D/B |
| PRE-SET BL.HSK 63A | for tool holders HSK 63A/C/E |
| PRE-SET BL.HSK 80A | for tool holders HSK 80 |
| PRE-SET BL.30x130 | with arbor L=130, for tools with bore d= 30 |
| PRE-SET BL.30x300 | with arbor L=300, for tools with bore d= 30 |
| PRE-SET BL.35x130 | with arbor L=130, for tools with bore d= 35 |
| PRE-SET BL.35x300 | with arbor L=300, for tools with bore d= 35 |
| PRE-SET BL.40x130 | with arbor L=130, for tools with bore d= 40 |
| PRE-SET BL.40x300 | with arbor L=300, for tools with bore d= 40 |
| PRE-SET BL.50x130 | with arbor L=130, for tools with bore d= 50 |
| PRE-SET BL.50x300 | with arbor L=300, for tools with bore d= 50 |

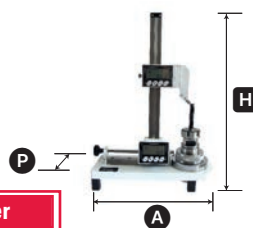

| P368 | Dimensions | Weight | Power |
|------|----------------------|--------|--|
| LR | A 410-P 150-H 540 mm | 12 kg | 2 AA Batteries each display (included) |

CRATE

| P368 | Dimensions | Weight |
|------|----------------------|---------|
| LR | A 610-P 485-H 210 mm | 15,3 kg |

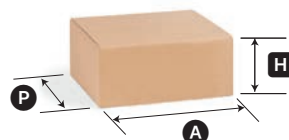

PRE SET P368XL

The **Preset P368** is a precise instrument, easy and quick to use: these characteristics have been especially designed to meet the requirements of the NC machine operator. It is used in the wood, metal and glass machining industries where the tools must be pre-set or adjusted. The **Preset P368XL**, can be used for both measuring lengths and radius of the tools. The **Preset P368XL** is necessary when working with tools with diameter up to 400 mm.

| Item | Measuring range |
|----------------|---------------------|
| PRE-SET P368XL | H 300 mm - Ø 400 mm |



Height measurement
The P368 is a very solid presetter designed to make tool height measurement very simple and always accurate.



Diameter measurement
The P368 has a solid base and provides smooth and accurate linear movements. The tool radius/diameter is always precise.

Axis Z
Slide guide in anti-friction material.



TECHNICAL FEATURES

- Excellent price/quality relationship
- Considerable cutback of tooling-up times, no waste of material
- 4 machine origins
- It measures all types of tools
- Battery powered – no need of electrical plug
- Large display easy to read
- One touch conversion mm/inch
- Interchangeable cone holders (ISO, HSK, VDI, arbors)

Measurement detection: Precision magnetic strip

| Item |
|---------------|
| T. SFERA-P368 |



Spherical feeler for shaped cutters (Optional)

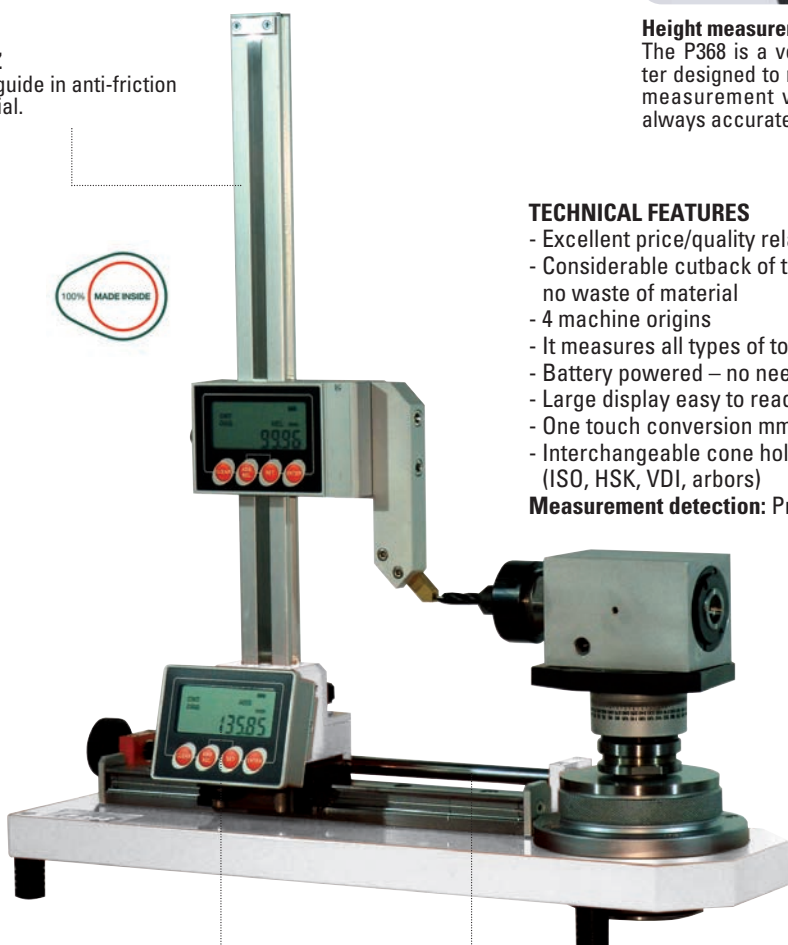

No. 2 displays with big numbers are connected to the magnetic strips for measurements detection of axis X and Z.

Axis X
Preloaded recirculating ball-bearing guides.



The **preset P368XL** is supplied with a cone-holder (ISO30, ISO40, ISO50) on your choice. Other cone-holders can also be purchased later.

SPARE CONE-HOLDERS

| Item | Description |
|--------------------|---|
| PRE-SET BL.ISO 30 | for tool holders ISO 30 |
| PRE-SET BL.ISO 40 | for tool holders ISO 40 |
| PRE-SET BL.ISO 50 | for tool holders ISO 50 |
| PRE-SET BL.HSK 63F | for tool holders HSK 63F/D/B |
| PRE-SET BL.HSK 63A | for tool holders HSK 63A/C/E |
| PRE-SET BL.HSK 80A | for tool holders HSK 80 |
| PRE-SET BL.30x130 | with arbor L=130, for tools with bore d= 30 |
| PRE-SET BL.30x300 | with arbor L=300, for tools with bore d= 30 |
| PRE-SET BL.35x130 | with arbor L=130, for tools with bore d= 35 |
| PRE-SET BL.35x300 | with arbor L=300, for tools with bore d= 35 |
| PRE-SET BL.40x130 | with arbor L=130, for tools with bore d= 40 |
| PRE-SET BL.40x300 | with arbor L=300, for tools with bore d= 40 |
| PRE-SET BL.50x130 | with arbor L=130, for tools with bore d= 50 |
| PRE-SET BL.50x300 | with arbor L=300, for tools with bore d= 50 |

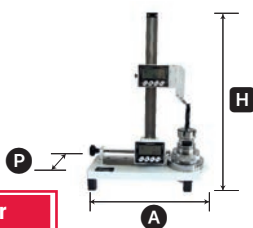

| P368 | Dimensions | Weight | Power |
|------|----------------------|--------|--|
| XL | A 490-P 200-H 580 mm | 33 kg | 2 AA Batteries each display (included) |

CRATE

| P368 | Dimensions | Weight |
|------|----------------------|--------|
| XL | A 700-P 570-H 380 mm | 40 kg |

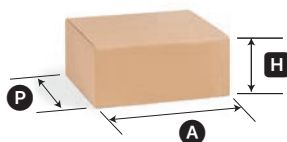

ANGOLFAST

The right instruments for measuring angles



**PRECISE
STURDY
VERSATILE
LIGHT
HANDY
SIMPLE**

| Item | Dimension |
|---------------|--------------------------------|
| ANGOLFAST 45 | 450 mm |
| ANGOLFAST 70 | 700 mm |
| ANGOLFAST 70S | 700 mm with reference shoulder |

Angolfast is made of anodized aluminium, so it is very sturdy but at the same time light and easy to use. It features a shockproof spirit-level and can measure inner angles between 20-135°.

These in brief are the characteristics of this instrument, useful for:

**INTERIOR DECORATORS
KITCHEN UNIT MANUFACTURERS
FRAME INSTALLERS
BRICKLAYERS
CARPENTERS
SMITHS
SURVEYORS
ARCHITECTS**



Examples of use

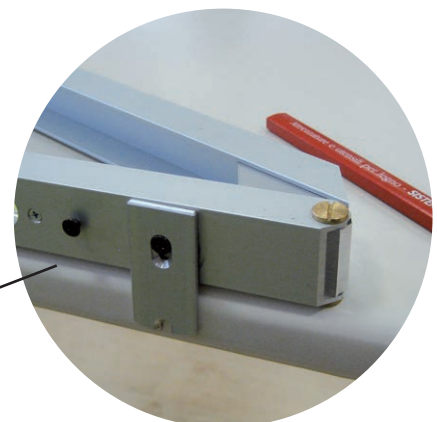

Angolfast 70S with reference shoulder for easier outlining.

GAUGES

Modern panel working production technologies have made indispensable the use of appropriate measuring instruments sufficiently precise to achieve high quality standards. The line of gauges shown below has been designed to meet all woodworking measurement needs and these gauges are commonly used even in the working of **aluminium, glass** and **sheet metals**. All the gauges are made of chromium-plate steel with inscribed scale and coloured black; **PRECISION** of **0,1 mm**.

GAUGE FOR LINEAR MEASUREMENTS

ART. C.LIN

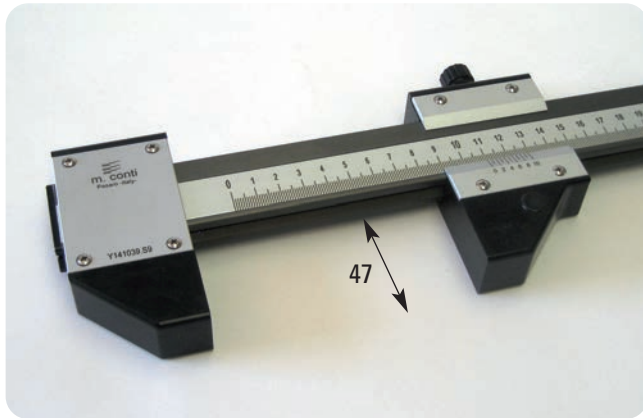

Suitable for measuring wood panel widths and lengths, but also for glass, aluminium profiles and sheet metal.



| Item | Measuring range |
|------------|-----------------|
| C.LIN.0500 | 0÷500 |
| C.LIN.0750 | 0÷750 |
| C.LIN.1000 | 0÷1000 |
| C.LIN.1500 | 0÷1500 |
| C.LIN.2000 | 0÷2000 |
| C.LIN.2500 | 0÷2500 |
| C.LIN.3200 | 0÷3200 |

GAUGE FOR LINEAR MEASUREMENTS WITH STEEL PLATES

ART. C.LIN.PA

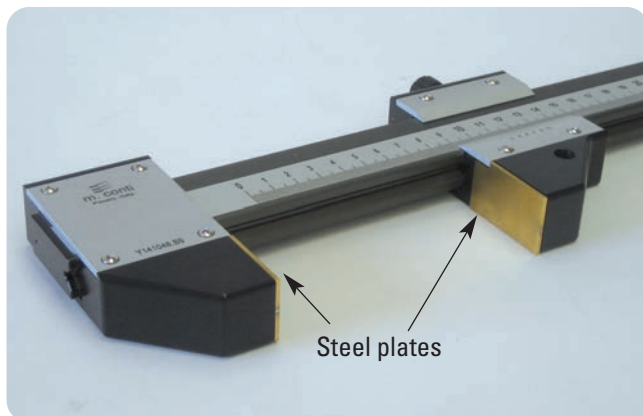

Suitable for measuring widths and lengths in glass, aluminium and sheet metal items.

Plates in TIN coated high resistance steel.

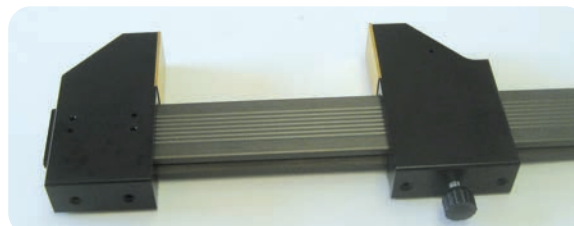

| Item | Measuring range |
|--------------|-----------------|
| C.LIN.PA0500 | 0÷500 |
| C.LIN.PA0750 | 0÷750 |
| C.LIN.PA1000 | 0÷1000 |
| C.LIN.PA1500 | 0÷1500 |
| C.LIN.PA2000 | 0÷2000 |
| C.LIN.PA2500 | 0÷2500 |
| C.LIN.PA3200 | 0÷3200 |

GAUGE FOR DISTANCE BETWEEN HOLES

ART. C.INT

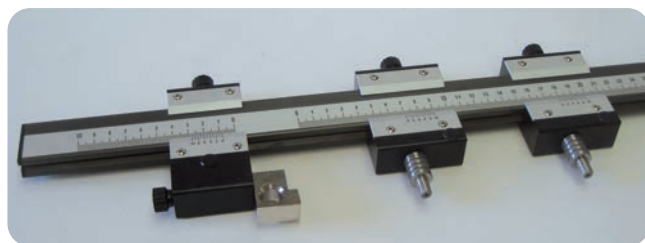

Practically indispensable for correctly measuring the distance from the edge of the panel to the centre of holes or the centre distance between one hole and another.
Supplied with one semi-fixed slider and two moving sliders with dia. 8 pin.



| Item | Measuring range |
|-----------|-----------------|
| C.INT0500 | 0÷500 |
| C.INT0750 | 0÷750 |
| C.INT1000 | 0÷1000 |
| C.INT1500 | 0÷1500 |
| C.INT2000 | 0÷2000 |
| C.INT2500 | 0÷2500 |
| C.INT3200 | 0÷3200 |

Spare parts

C.CORS.PER Spare slider complete with pin



C.PER.0415 Conical pin for dia. 4 - dia. 15 holes



C.PERNO.03 For hole Ø 3

C.PERNO.04 For hole Ø 4

C.PERNO.05 For hole Ø 5

C.PERNO.06 For hole Ø 6

C.PERNO.07 For hole Ø 7

C.PERNO.08 For hole Ø 8

C.PERNO.09 For hole Ø 9

C.PERNO.10 For hole Ø 10

C.PERNO.12 For hole Ø 12



C.PERNO.14 For hole Ø 14

C.PERNO.15 For hole Ø 15

C.PERNO.16 For hole Ø 16

C.PERNO.18 For hole Ø 18

C.PERNO.20 For hole Ø 20

C.PERNO.25 For hole Ø 25

C.PERNO.26 For hole Ø 26

C.PERNO.30 For hole Ø 30

C.PERNO.35 For hole Ø 35



GAUGE FOR 90° V-FOLD CUTS

ART. C.INV

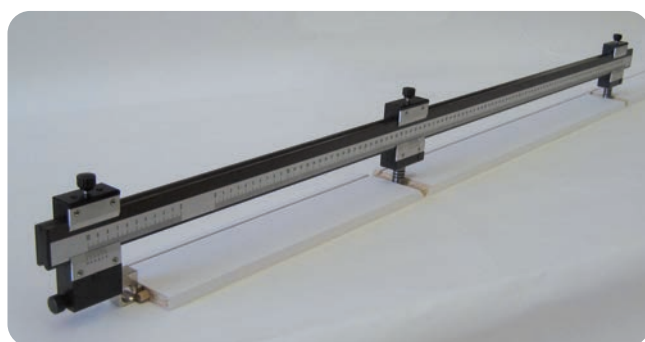

Suitable for the production of drawers, it features a semi-fixed slider and two moving sliders with V-90° pin.

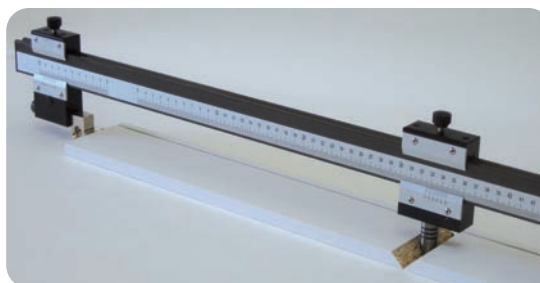

| Item | Measuring range |
|-----------|-----------------|
| C.INV1000 | 550÷0÷1000 |
| C.INV1500 | 550÷0÷1500 |
| C.INV2000 | 550÷0÷2000 |

Spare parts

C.CORS.V90° Spare slider complete with pin

C.PERS.V90° V-90° pin

GAUGE FOR INSIDE/OUTSIDE MEASURING

ART. C.LIE

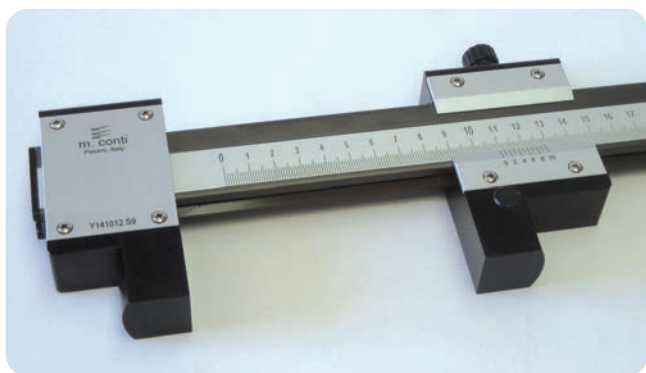

Suitable for measuring big dimension openings (min. 50 mm) on wood panels and frames. For inside measurings mm 50 is to be added.

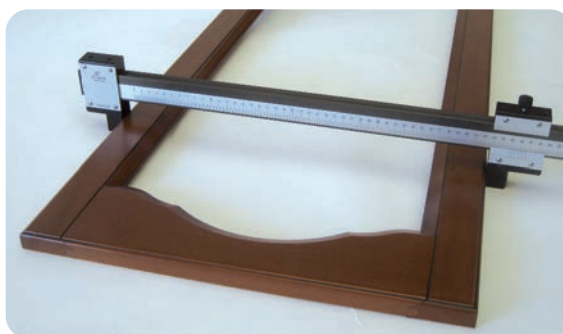
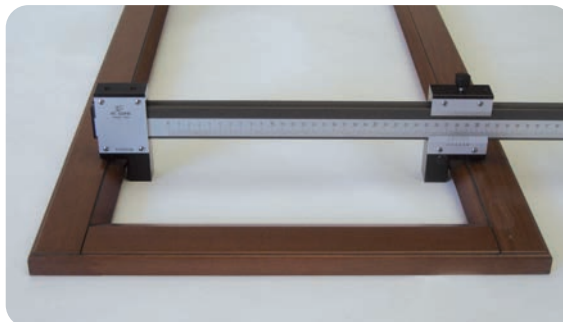

| Item | Measuring range |
|-----------|-----------------|
| C.LIE0500 | 0÷500 |
| C.LIE0750 | 0÷750 |
| C.LIE1000 | 0÷1000 |
| C.LIE1500 | 0÷1500 |
| C.LIE2000 | 0÷2000 |
| C.LIE2500 | 0÷2500 |
| C.LIE3200 | 0÷3200 |

GAUGE FOR INSIDE/OUTSIDE MEASURING WITH STEEL PLATES

ART. C.LIE.PA

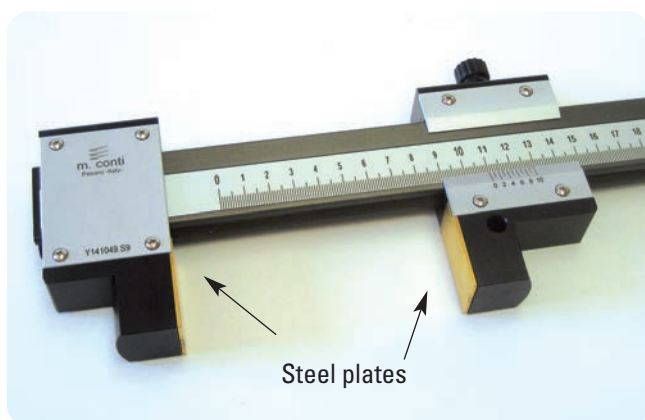

Suitable for measuring big dimension openings (min. 50 mm) on glass, alu, metal and PVC items.

Plates in TIN coated high resistance steel.

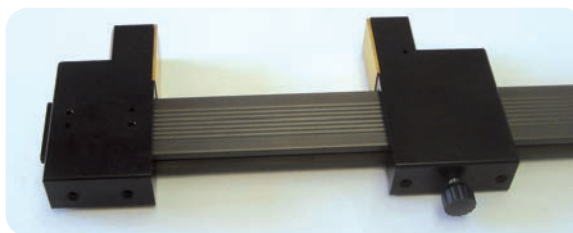

| Item | Measuring range |
|--------------|-----------------|
| C.LIE.PA0500 | 0÷500 |
| C.LIE.PA0750 | 0÷750 |
| C.LIE.PA1000 | 0÷1000 |
| C.LIE.PA1500 | 0÷1500 |
| C.LIE.PA2000 | 0÷2000 |
| C.LIE.PA2500 | 0÷2500 |
| C.LIE.PA3200 | 0÷3200 |

GAUGE FOR LINEAR MEASUREMENTS AND DISTANCE BETWEEN CENTRES

ART. C.LIN.PI

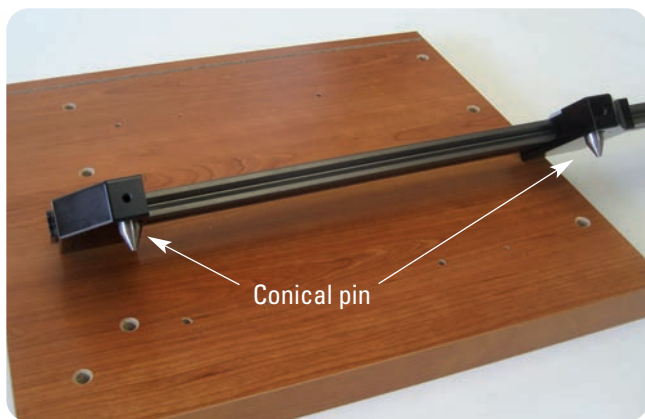

The length is read directly on the graduated scale, the hole distance is obtained by adding 20 mm to the value read on the scale. Two tapered pins are supplied as standard $\varnothing 4/\varnothing 15$ mm.



| Item | Measuring range |
|--------------|-----------------|
| C.LIN.PI0500 | 0÷500 |
| C.LIN.PI0750 | 0÷750 |
| C.LIN.PI1000 | 0÷1000 |
| C.LIN.PI1500 | 0÷1500 |
| C.LIN.PI2000 | 0÷2000 |
| C.LIN.PI2500 | 0÷2500 |
| C.LIN.PI3200 | 0÷3200 |

Spare parts

| | |
|------------|-----------------------------------|
| C.PER.1415 | Conical pin for dia. 4 ÷ 15 holes |
|------------|-----------------------------------|

GAUGE FOR LINEAR MEASUREMENTS, DISTANCE FROM THE CENTRES OF THE HOLE TO THE EDGE OF THE PANEL

ART. C.LIN.PB

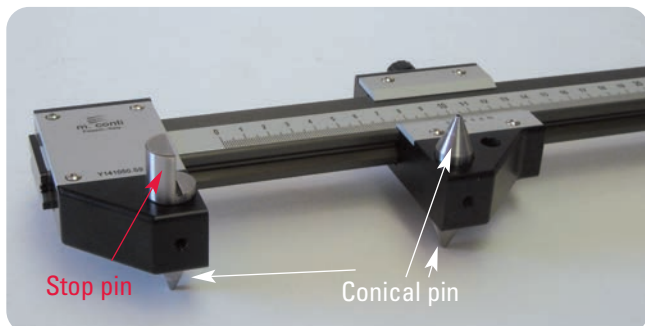

The length is read directly on the graduated scale, the hole distance is obtained by adding 20 mm to the value read on the scale.

Two pins are supplied as standard (one tapered of $\varnothing 4/\varnothing 15$ mm and one as stop).

With the left pin the distance between the edge of the panel and the centre of the hole can be measured.



Measuring of the distance of panel edge to the hole centres

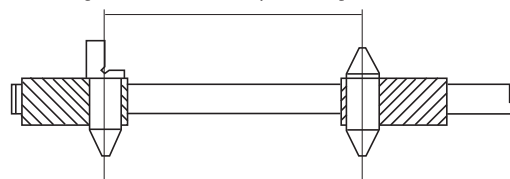

Measuring of distance between hole centres

| Item | Measuring range |
|--------------|-----------------|
| C.LIN.PB0500 | 0÷500 |
| C.LIN.PB0750 | 0÷750 |
| C.LIN.PB1000 | 0÷1000 |
| C.LIN.PB1500 | 0÷1500 |
| C.LIN.PB2000 | 0÷2000 |
| C.LIN.PB2500 | 0÷2500 |
| C.LIN.PB3200 | 0÷3200 |

Spare parts

| | | |
|------------|-----------------------------------|--|
| C.PER.1415 | Conical pin for dia. 4 ÷ 15 holes |  |
|------------|-----------------------------------|--|

| | | |
|-----------|----------|---|
| C.PER.B12 | Stop pin |  |
|-----------|----------|---|

GAUGE FOR LINEAR MEASUREMENTS, WITH LONG JAWS

ART. C.LIN.L

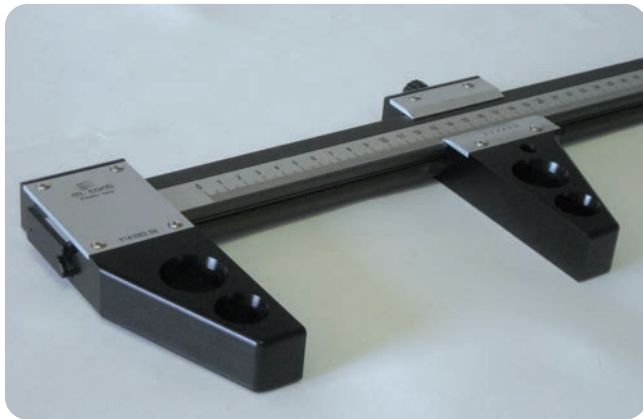

Suitable for measuring width and length of wood panel
JAW LENGTH 97 mm.

| Item | Measuring range |
|-------------|-----------------|
| C.LIN.L0500 | 0÷500 |
| C.LIN.L0750 | 0÷750 |
| C.LIN.L1000 | 0÷1000 |
| C.LIN.L1500 | 0÷1500 |
| C.LIN.L2000 | 0÷2000 |
| C.LIN.L2500 | 0÷2500 |
| C.LIN.L3200 | 0÷3200 |

GAUGE FOR LINEAR MEASUREMENTS, WITH LONG JAWS AND STEEL PLATES

ART. C.LIN.L.PA

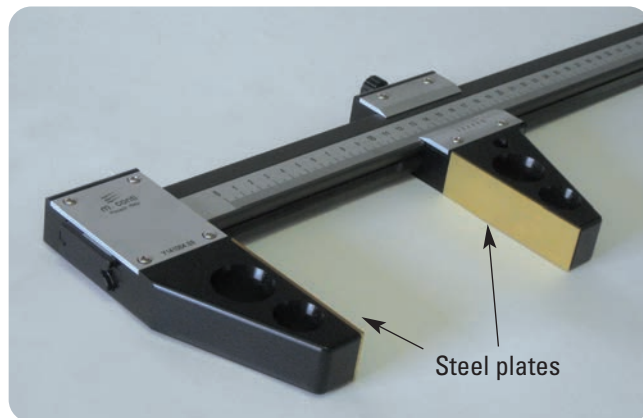

Suitable for measuring the width and length of glass and aluminium items and when cutting sheet metal.

JAW LENGTH 97 mm.

Plates in TIN coated high resistance steel.

| Item | Measuring range |
|----------------|-----------------|
| C.LIN.L.PA0500 | 0÷500 |
| C.LIN.L.PA0750 | 0÷750 |
| C.LIN.L.PA1000 | 0÷1000 |
| C.LIN.L.PA1500 | 0÷1500 |
| C.LIN.L.PA2000 | 0÷2000 |
| C.LIN.L.PA2500 | 0÷2500 |
| C.LIN.L.PA3200 | 0÷3200 |

GAUGE FOR 45° CUTS

ART. C.L45

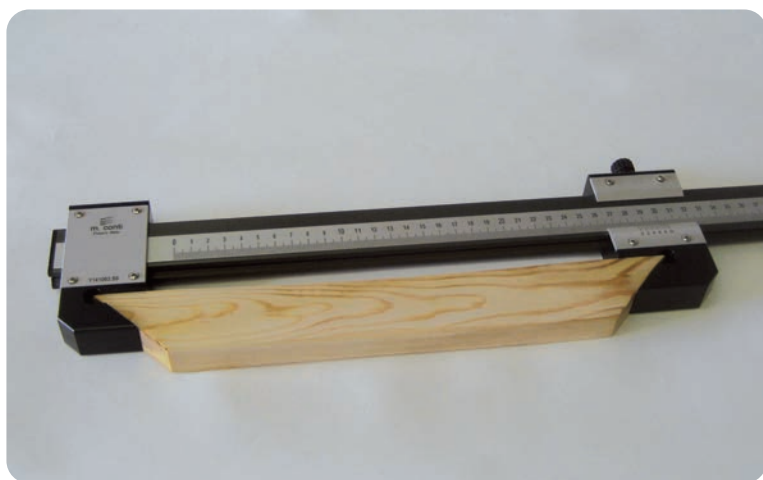

Suitable for the production of frames, sashes and other components with 45° angles.
Minimum measurable length - 80mm.

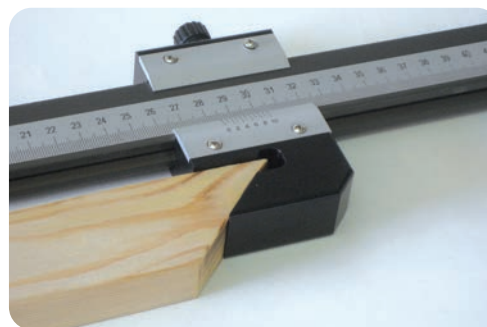

| Item | Measuring range |
|------------|-----------------|
| C.L45.0500 | 80÷500 |
| C.L45.0750 | 80÷750 |
| C.L45.1000 | 80÷1000 |
| C.L45.1500 | 80÷1500 |
| C.L45.2000 | 80÷2000 |
| C.L45.2500 | 80÷2500 |
| C.L45.3200 | 80÷3200 |

GAUGE FOR DIAGONAL AND OUT OF SQUARE MEASUREMENTS

ART. C.LIN.D

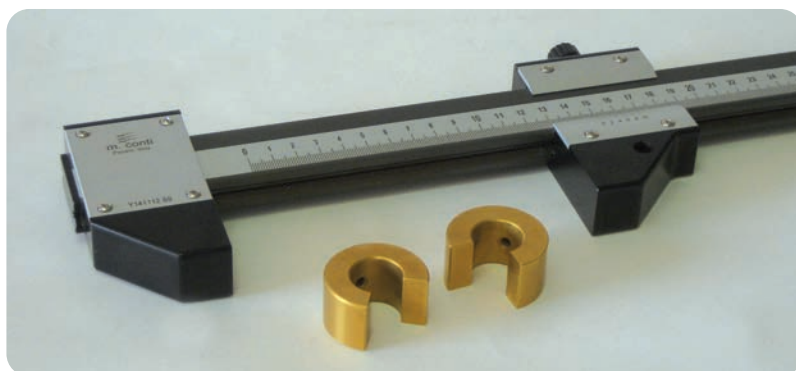

Suitable for measuring the out of square of a panel or any diagonal line



2 reference steel discs included

| Item | Measuring range |
|--------------|-----------------|
| C.LIN.D.0500 | 0÷500 |
| C.LIN.D.0750 | 0÷750 |
| C.LIN.D.1000 | 0÷1000 |
| C.LIN.D.1500 | 0÷1500 |
| C.LIN.D.2000 | 0÷2000 |
| C.LIN.D.2500 | 0÷2500 |
| C.LIN.D.3200 | 0÷3200 |

Spare parts

| | |
|-----------|---------------------------------------|
| C.DIS.040 | D=40 - 90° cut - Reference steel disc |
|-----------|---------------------------------------|

OPTICAL LENS

ART. C.LETTORE



Magnifying glass used to improve the evaluation of the scale in case of reading from a distance.
Made of anodized aluminium dia. 50 mm, it can be used with any gauge.

| Item | Dimensions |
|-----------|------------|
| C.LETTORE | Ø 50 |

GAUGE CASE

ART. AST.CAL



Very useful for protecting the gauge when this is not in use or for transport.
Made of wood.

| Item | Dimensions |
|----------|------------|
| AST.CAL. | 800X150 |

CALIBRATION CERTIFICATE

ART. CERT.

On request, all gauges can be supplied with our calibration certificate which certifies the accuracy every 100 mm.
The gauges are tested using certified gauge blocks.

| Item | Gauge measuring range |
|-----------|-----------------------|
| CERT.0500 | 500 |
| CERT.0750 | 750 |
| CERT.1000 | 1000 |
| CERT.1500 | 1500 |
| CERT.2000 | 2000 |
| CERT.2500 | 2500 |
| CERT.3200 | 3200 |

GAUGES DIGIT +

The **Digit +** digital gauges have been designed and developed to meet the need to take as quickly as possible the measurements of the dimensions of the panels in the production units.

Thanks to digital technology and to the large and easy to use display, the subjectivity of the operator is bypassed and the maximum precision is ensured.

All **Digit +** can be supplied on request with centesimal resolution (0.01 mm) and / or serial output.

GAUGES FOR LINEAR MEASUREMENTS

ART. DIGIT950



- Resolution 0,1 mm
- Light, precise and easy to use
- Battery powered (1 battery 1,5 V type AA)
- Measuring system by magnetic strip our production
- Display functions:
 - absolute/relative
 - selection of measuring mode
 - programmable automatic shutdown
 - mm/inches conversion
 - large display for easy reading
- Bars and jaws are made of anodized aluminium with 500 HV hardness on the surface

| Item | Measuring range |
|---------------|-----------------|
| DIGIT950.0500 | 0÷500 |
| DIGIT950.0750 | 0÷750 |
| DIGIT950.1000 | 0÷1000 |
| DIGIT950.1500 | 0÷1500 |
| DIGIT950.2000 | 0÷2000 |
| DIGIT950.2500 | 0÷2500 |
| DIGIT950.3100 | 0÷3100 |

GAUGES FOR LINEAR-INSIDE/OUTSIDE MEASUREMENTS

ART. DIGIT955

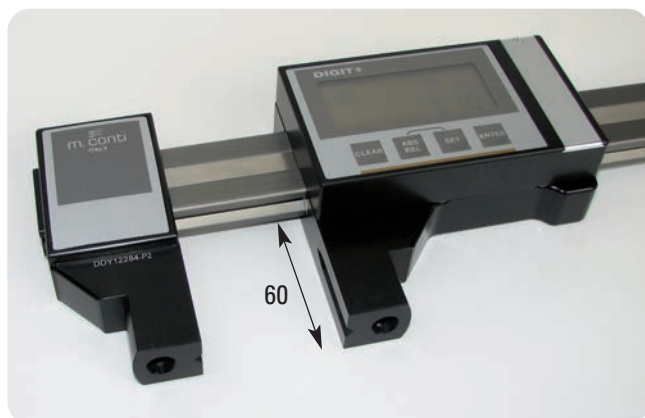

- Resolution 0,1 mm
- Light, precise and easy to use
- Battery powered (1 battery 1,5 V type AA)
- Measuring system by magnetic strip our production
- Display functions:
 - absolute/relative
 - selection of measuring mode
 - programmable automatic shutdown
 - mm/inches conversion
 - large display for easy reading
- Bars and jaws are made of anodized aluminium with 500 HV hardness on the surface

Optional kit: two pins (Ø4-15) for measuring distance between holes + reference jig for measuring distance between hole and edge of the panel.

| Item | Measuring range |
|---------------|-----------------|
| DIGIT955.0500 | 0÷500 |
| DIGIT955.0750 | 0÷750 |
| DIGIT955.1000 | 0÷1000 |
| DIGIT955.1500 | 0÷1500 |
| DIGIT955.2000 | 0÷2000 |
| DIGIT955.2500 | 0÷2500 |
| DIGIT955.3100 | 0÷3100 |

GAUGE FOR LINEAR, INSIDE/OUTSIDE, DISTANCE BETWEEN HOLES, OUT OF SQUARE ANGLES MEASUREMENTS

ART. DIGIT990



- Resolution 0,1 mm
- Light, precise and easy to use
- Battery powered (1 battery 1,5 V type AA)
- Measuring system by magnetic strip our production
- Display functions:
 - absolute/relative
 - selection of measuring mode
 - programmable automatic shutdown
 - mm/inches conversion
 - large display for easy reading
- Bars and jaws are made of anodized aluminium with 500 HV hardness on the surface

Complete with no° two pins (Ø4-15) for measuring distance between holes + reference jig for measuring distance between hole and edge of the panel.

| Item | Measuring range |
|---------------|-----------------|
| DIGIT990.0500 | 0÷500 |
| DIGIT990.0750 | 0÷750 |
| DIGIT990.1000 | 0÷1000 |
| DIGIT990.1500 | 0÷1500 |
| DIGIT990.2000 | 0÷2000 |
| DIGIT990.2500 | 0÷2500 |
| DIGIT990.3100 | 0÷3100 |

Spare parts

C.PER.1415 Conical pin for dia. 4 ÷ 15 holes



GAUGE FOR 45° CUTS

ART. DIGIT991

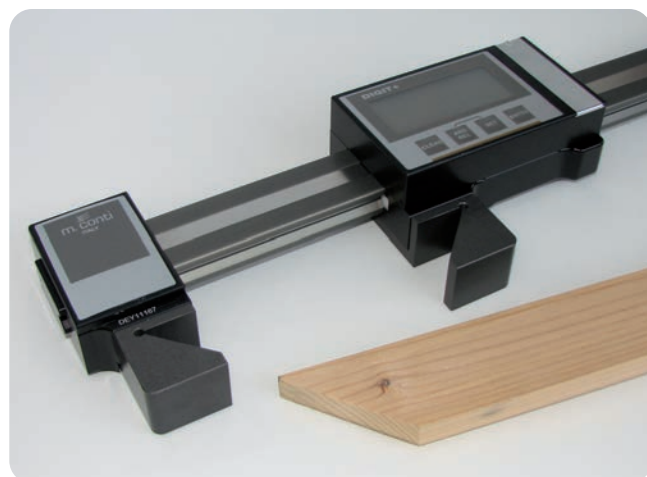

- Resolution 0,1 mm
- Light, precise and easy to use
- Battery powered (1 battery 1,5 V type AA)
- Measuring system by magnetic strip our production
- Display functions:
 - absolute/relative
 - selection of measuring mode
 - programmable automatic shutdown
 - mm/inches conversion
 - large display for easy reading
- Bars and jaws are made of anodized aluminium with 500 HV hardness on the surface

Suitable for the production of frames, sashes and other components with 45° angles.
Minimum measurable length - 80mm.

| Item | Measuring range |
|---------------|-----------------|
| DIGIT991.0750 | 0÷750 |
| DIGIT991.1000 | 0÷1000 |
| DIGIT991.1500 | 0÷1500 |
| DIGIT991.2000 | 0÷2000 |
| DIGIT991.2500 | 0÷2500 |
| DIGIT991.3100 | 0÷3100 |

**GAUGE FOR LINEAR, INSIDE/OUTSIDE, DISTANCE BETWEEN HOLES, OUT OF SQUARE ANGLES MEASUREMENTS
DIGIT992**



- Resolution 0,1 mm
- Light, precise and easy to use
- Battery powered (1 battery 1,5 V type AA)
- Measuring system by magnetic strip our production
- Display functions:
 - absolute/relative
 - selection of measuring mode
 - programmable automatic shutdown
 - mm/inches conversion
 - large display for easy reading



2 reference steel discs included

| Item | Measuring range |
|---------------|-----------------|
| DIGIT992.1000 | 0÷1000 |
| DIGIT992.1500 | 0÷1500 |
| DIGIT992.2000 | 0÷2000 |
| DIGIT992.2500 | 0÷2500 |
| DIGIT992.3100 | 0÷3100 |

Spare parts

| | |
|------------|--|
| C.DIS.040 | D=40 - 90° cut - Reference steel disc (included) |
| C.PER.1415 | Conical pin for dia. 4 ÷ 15 holes (not included) |



visit our website

www.sistemiklein.com



GAUGE FOR LINEAR MEASUREMENTS WITH LONG JAWS AND STEEL PLATES

ART. DIGIT980/985/986/987

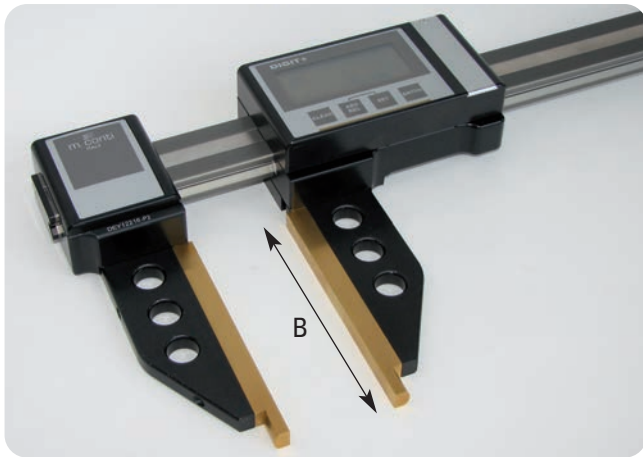

- Resolution 0,1 mm
- Light-weight but at the same time rigid and accurate
- Battery-powered (nr. 1 Battery 1,5 type AA)
- Measuring system by magnetic strip our production
- Main display features: absolute/relative measuring, selection of measuring mode, programmable automatic shutdown, mm/inch conversion, large numbers display for easy reading.

- **STEEL PLATES**
- **JAWS WITH LIGHTENING HOLES**

| Item | Measuring range | B | Item | Measuring range | B |
|---------------|-----------------|-----|---------------|-----------------|-----|
| DIGIT980.1000 | 0÷1000 | 100 | DIGIT986.1000 | 0÷1000 | 200 |
| DIGIT980.1500 | 0÷1500 | 100 | DIGIT986.1500 | 0÷1500 | 200 |
| DIGIT980.2000 | 0÷2000 | 100 | DIGIT986.2000 | 0÷2000 | 200 |
| DIGIT980.2500 | 0÷2500 | 100 | DIGIT986.2500 | 0÷2500 | 200 |
| DIGIT980.3100 | 0÷3100 | 100 | DIGIT986.3100 | 0÷3100 | 200 |
| DIGIT985.1000 | 0÷1000 | 150 | DIGIT987.1000 | 0÷1000 | 300 |
| DIGIT985.1500 | 0÷1500 | 150 | DIGIT987.1500 | 0÷1500 | 300 |
| DIGIT985.2000 | 0÷2000 | 150 | DIGIT987.2000 | 0÷2000 | 300 |
| DIGIT985.2500 | 0÷2500 | 150 | DIGIT987.2500 | 0÷2500 | 300 |
| DIGIT985.3100 | 0÷3100 | 150 | DIGIT987.3100 | 0÷3100 | 300 |

GAUGE WITH NONIUS FOR LINEAR-INSIDE/OUTSIDE MEASUREMENTS WITH LONG JAWS AND STEEL PLATES

ART. C.LIE.L.PA

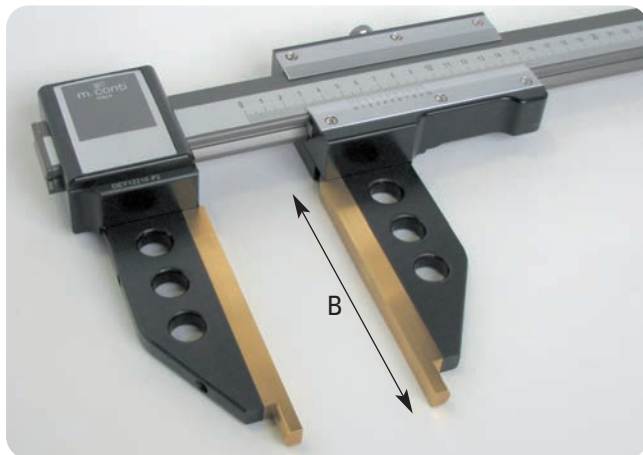

- Resolution 0,1 mm
- Light, precise and easy to use
- Suitable for measuring glass , aluminum, metal or PVC items
- Also fit for measuring parts in the metalworking industry

- **STEEL PLATES**
- **JAWS WITH LIGHTENING HOLES**

| Item | Measuring range | B | Item | Measuring range | B |
|---------------------|-----------------|-----|---------------------|-----------------|-----|
| C.LIE.L.PA.1000.100 | 0÷1000 | 100 | C.LIE.L.PA.1000.200 | 0÷1000 | 200 |
| C.LIE.L.PA.1500.100 | 0÷1500 | 100 | C.LIE.L.PA.1500.200 | 0÷1500 | 200 |
| C.LIE.L.PA.2000.100 | 0÷2000 | 100 | C.LIE.L.PA.2000.200 | 0÷2000 | 200 |
| C.LIE.L.PA.2500.100 | 0÷2500 | 100 | C.LIE.L.PA.2500.200 | 0÷2500 | 200 |
| C.LIE.L.PA.3100.100 | 0÷3100 | 100 | C.LIE.L.PA.3100.200 | 0÷3100 | 200 |
| C.LIE.L.PA.1000.150 | 0÷1000 | 150 | C.LIE.L.PA.1000.300 | 0÷1000 | 300 |
| C.LIE.L.PA.1500.150 | 0÷1500 | 150 | C.LIE.L.PA.1500.300 | 0÷1500 | 300 |
| C.LIE.L.PA.2000.150 | 0÷2000 | 150 | C.LIE.L.PA.2000.300 | 0÷2000 | 300 |
| C.LIE.L.PA.2500.150 | 0÷2500 | 150 | C.LIE.L.PA.2500.300 | 0÷2500 | 300 |
| C.LIE.L.PA.3100.150 | 0÷3100 | 150 | C.LIE.L.PA.3100.300 | 0÷3100 | 300 |

GAUGE WITH WIRELESS CONNECTION FOR LINEAR MEASUREMENTS

ART. DIGIT950



The DIGIT+ RF have a sender integrated in the caliper and a separate Master for receiving the data appearing on the display of the digital caliper and sent via **radio frequency**.

The Receiver must be connected to a Computer or any device able to process an ASCII string via RS232. In open space the transmission distance is approx. **50 meters**.

| Item | Measuring range |
|-----------------|-----------------|
| DIGIT950.1000RF | 0÷1000 |
| DIGIT950.1500RF | 0÷1500 |
| DIGIT950.2000RF | 0÷2000 |
| DIGIT950.2500RF | 0÷2500 |
| DIGIT950.3100RF | 0÷3100 |

GAUGE WITH WIRELESS CONNECTION FOR LINEAR, INSIDE/OUTSIDE, DISTANCE BETWEEN HOLES, OUT OF SQUARE ANGLES MEASUREMENTS

ART. DIGIT990



The DIGIT+ RF have a sender integrated in the caliper and a separate Master for receiving the data appearing on the display of the digital caliper and sent via **radio frequency**.

The Receiver must be connected to a Computer or any device able to process an ASCII string via RS232. In open space the transmission distance is approx. **50 meters**.

| Item | Measuring range |
|-----------------|-----------------|
| DIGIT990.1000RF | 0÷1000 |
| DIGIT990.1500RF | 0÷1500 |
| DIGIT990.2000RF | 0÷2000 |
| DIGIT990.2500RF | 0÷2500 |
| DIGIT990.3100RF | 0÷3100 |



MAGNETIC STRIP MEASURING SYSTEM

A fast and accurate system which allows reading of measurements directly on the M10 display. It is extremely easy to apply – just fix the magnetic strip on a suitable surface of the machine with double-sided adhesive tape and fit the display with the sensor on the movable part. When movement is made, the display indicates the position with respect to a machine reference. The measuring system can be used on PANEL SIZING MACHINES, ROLLER BEDS FOR MITRE SAWS, BORING MACHINES, CIRCULAR SAWS etc.



| Item | Dimension |
|----------|-------------------------------|
| K.M.1000 | Magnetic strip length 1000 mm |
| K.M.1500 | Magnetic strip length 1500 mm |
| K.M.2000 | Magnetic strip length 2000 mm |
| K.M.3000 | Magnetic strip length 3000 mm |
| K.M.4500 | Magnetic strip length 4500 mm |

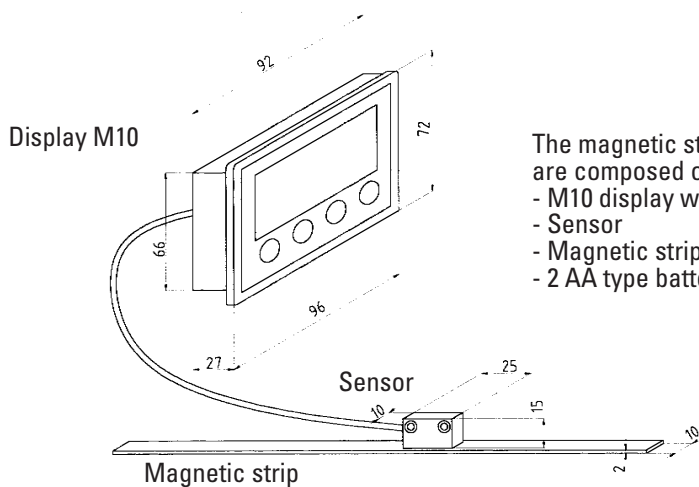

The magnetic strip measuring system is supplied in kits, they are composed of:

- M10 display with 0.5 m cable
- Sensor
- Magnetic strip (with double-sided tape)
- 2 AA type batteries



Application on panel sizing machines for squaring cuts

MAIN CHARACTERISTICS

- M10 display dimensions: 96x72x27 mm
- battery-powered with 1.5V AA type battery with a 12-month life
- system accuracy: 0.1 mm
- 5 incremental counting
- 5 programmable offsets
- programmable zero point
- battery check
- self diagnostic in real-time
- wide installation tolerances
- parameters stored in permanent memory
- battery voltage control shown on the display
- multifunction LCD display
- 4-key display keypad
- operating temperature: 5° - 60°C
- storage temperature: -20° - 70°C
- max. humidity: 95% (condensation not permitted)
- magnetic strip: 10x2 mm
- type of magnetic strip: MT500
- distance between magnetic strip and sensor: max. 2.5 mm

ELECTRONIC WORK STATION

For modern panel production for the furniture industry, adequate quality control is indispensable. During the production, to set up the manufacturing machines, at the end of the work shift for quality control, on acceptance of semi-finished products from third parties and for product certification, the electronic work station ensures the quality of your products and cuts machine stops and the time taken for assembly, there by increasing productivity.



| Item | Description |
|--------------|--|
| BCE 25 Y10-R | dimensions 2.500 mm x 1.000 mm - panel thickness 55 mm - precision 0,1 mm with 6-position revolver |



Execution with 6-position revolver to speed up feeler pin change

THANKS TO THIS WORK STATION YOU CAN CHECK

- Panel dimensions
- Out of square angles
- Distances between hole centres
- Parallelism and orthogonality between holes
- Depth of vertical and horizontal holes
- Dimension of grooves on panels
- Profiles on shaped panels
- Possibility of zero-setting to left and right

Watch the Video on
YouTube



Blocking system by means of 2 vacuum units
Useful when small panels are measured (optional)

The electronic workstation is a real "quality control station" able to check almost all dimensions on the length, width and thickness of the panel. **The tolerance of max. 0,1mm** mistake on the whole device surface is guaranteed. **First quality components** as well as highly automated processing cycle ensure the extreme precision of the workstation. Last production step consists in the complete and **scrupulous inspection effected** also using certified block gauges. The electronic workstation can also operate in dusty environment.

SOFTWARE (optional)

For a rational use of the electronic workstation , a special software program has been developed to suit the requirements of modern furniture production and semi-finished products.

Completely worked out at **M.Conti** in collaboration with expert computer engineers and advise from important manufacturing companies, the software has been developed considering and trying to solve all producers' requirements.

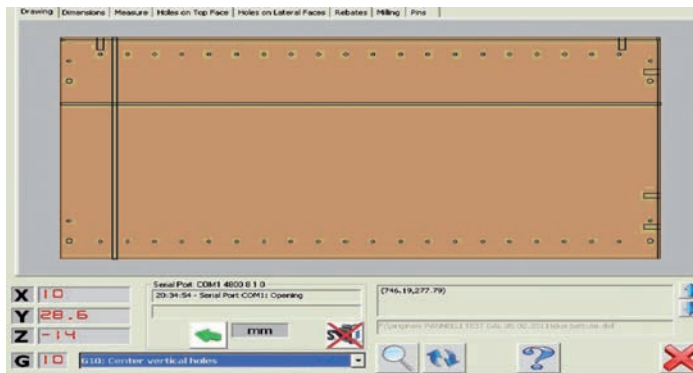
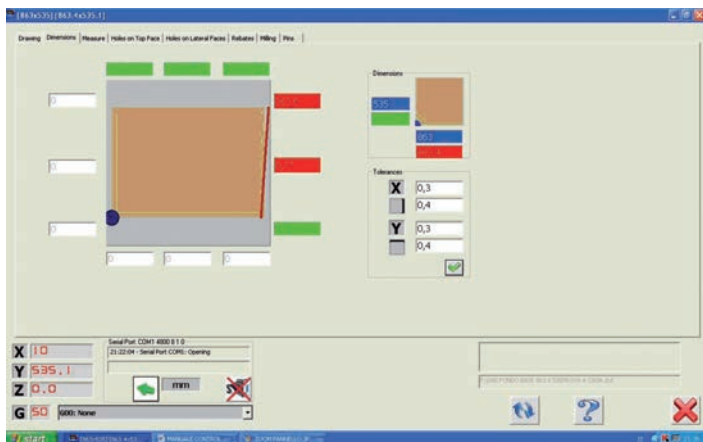

SOFTWARE SPECIFICATION

1) To **check and compare** a finished piece, or a CAD execution of the piece.

The elements which can be measured are:

1. Panel squaring
2. Vertical holes
3. Horizontal holes
4. Cuts
5. Relative distances

Using the software program we can visualize the measuring taken on the display and compare them with those requested thus detecting any mistake in production or out of tolerance dimension

A final report showing the measures taken can be printed, stored or attached to the production batch.

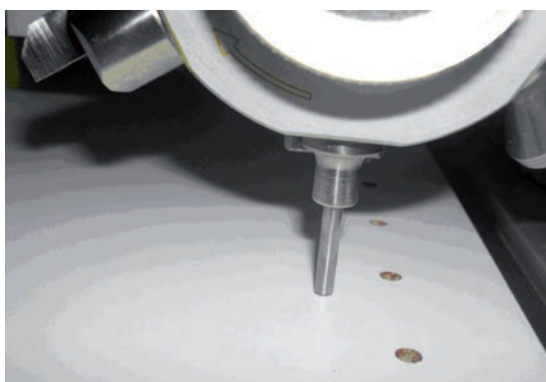
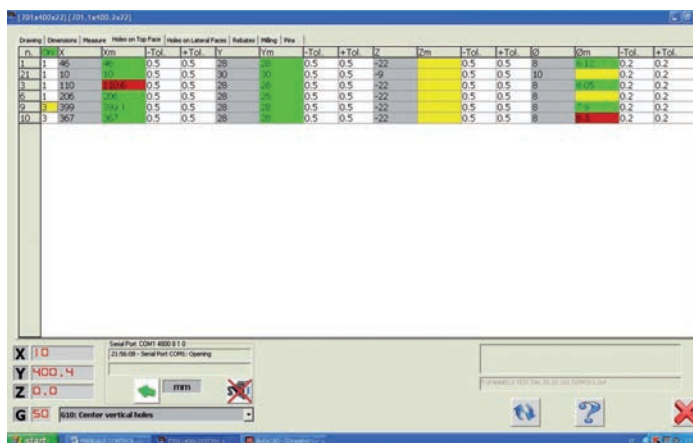

2) Graphic mode:

To **digitise a sample piece** and create a DXF file.

Necessary if you need to check the dimensions of a sample curves panel and save them in a DXF file in order to modify it with every CAD program

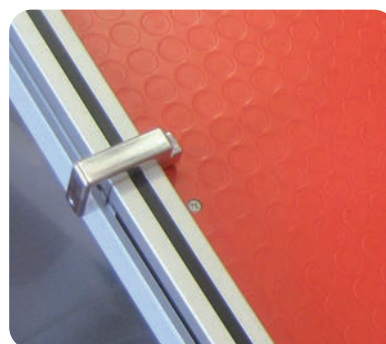

Side stop, longer execution (optional)



OPTIONAL FEATURES

| Item | Description |
|-----------|------------------------|
| AS1500201 | software program |
| SPP040077 | Z-axis |
| SPP040079 | panel hold down system |
| SPP040107 | additional vacuum unit |
| SPP040080 | 6 adapters revolver |
| AS1500224 | higher side stop |

Special devices

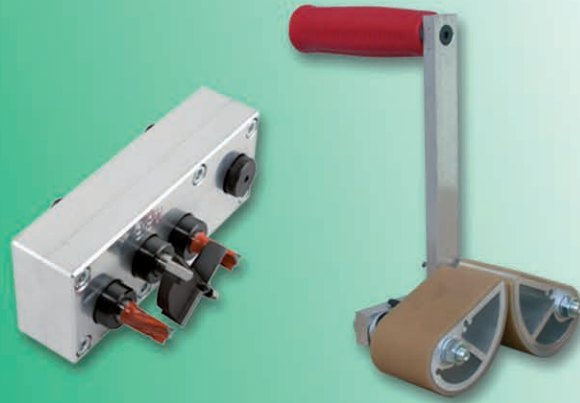

16



• "ARKADE+ZINKEL+ELLIX"
• Page 16.03 ÷ 16.05



• TRIMATIC FOR HINGES
• Page 16.06 - 16.07



• TRIMATIC 32
• Page 16.08



• DRILLING JIG FOR CREMONE BOLTS
• Page 16.09



• SPECIAL DEVICES FOR ANGULAR
• HINGES INSERTING
• Page 16.10



• TRIMATIC 22.4 FOR
• "LAMELLO" CABINEO®
• Page 16.11



• DRILLING JIG FOR MAKING HOLES
• FOR HINGE INSERTING
• Page 16.12 - 16.13



• DRILLING OF WOOD AND PVC
• WINDOW FRAME TO
• FIT CREMONE BOLT
• Page 16.13



• TRIMATIC SUPER 22.4 FOR
• "LAMELLO" CABINEO®
• Pag. 16.14



• DRILLING JIG FOR MAKING HOLES
• FOR HINGE INSERTING - 32/90°
• Page 16.14



• ECCENTRIC CLAMP
• Page 16.15

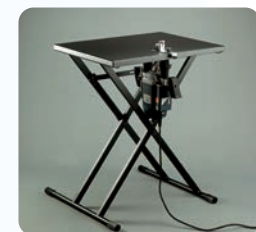

• ROUTER TABLE
• Page 16.15

Klein®





DRIVER FOR CURVES
Page 16.15



LIFTING CLAMP
Page 16.15



EDGE CLAMP
Page 16.16



T-JOINTS CLAMP
Page 16.16



CARPENTER'S CLAMP
Page 16.16



DOOR LIFTER
Page 16.16



**HORIZONTAL TYPE WITH
HORIZONTAL CLAMPING**
Page 16.17



**HORIZONTAL TYPE WITH
VERTICAL CLAMPING**
Page 16.17



PNEUMATIC TYPE
Page 16.17



PUSHER TYPE
Page 16.17



SPARE ENDPINS
Page 16.17



KLEIN WASHER
Page 16.18



KLEIN CLEANER
Page 16.18



SHRINK FIT UNIT
Page 16.18



COOLING UNIT WITH AIR FLOW
Page 16.18



**ANGLE HEADS FOR
CNC ROUTERS MACHINES**
Page 16.19 ÷ 16.21

“ARKADE+ZINKEL+ELLIX” - The complete routing system for arches

The building techniques of the ancient Greeks and Egyptians had not contemplated the joining of wall openings by the use of arches. Roman times brought great technological progress. Thanks to archlinking they were able to create wider openings and so this technique became increasingly popular. The greatest development and the most gracious examples of arch construction came during the middle ages and continued through the years until more modern times when other building methods largely replaced the use of arches. Modern day building construction has rediscovered the charm, aesthetic taste and practical aspects of archlinking and because of this our technical department has developed and patented **“ARKADE + ZINKEL”**. This is the only equipment on the market today capable of drawing and producing wooden, double-radius arch frames with practically no size restriction, quickly and with unmatched quality results.

“ARKADE” equipment can produce round and/or flat arches with minimum diameter 27 cm and maximum diameter 6m. If the **“ARKADE”** is complemented by **“ZINKEL”** equipment, it is also possible to make double-radius arches with a smaller radius between 13.5 and 80 cm and a larger radius of 3 m; and with particular accessories, even greater dimensions can be achieved. With **“ELLIX”** and some parts from **“ARKADE”** a perfect geometrical ellipses can be obtained.

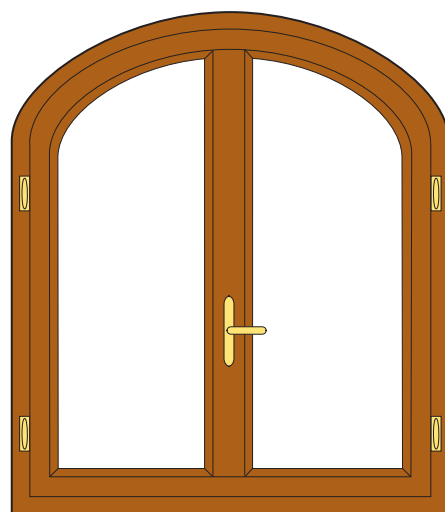

PATENT nr. AN93A000054



Item

ARKADE
“ARKADE” complete with tracer unit and goniometer



Item

ZINKEL
“ZINKEL” articulate accessory for double-radii arches



Item

ELLIX
“ELLIX” the equipment for perfect geometrical ellipse for customers already using **“ARKADE”**

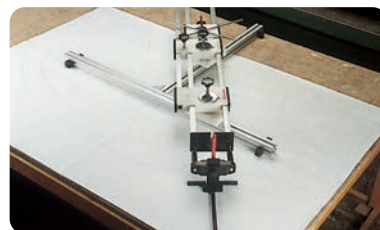
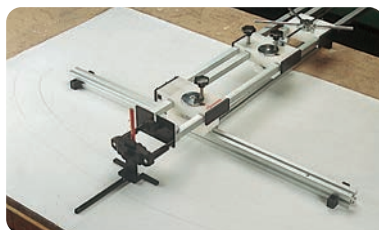
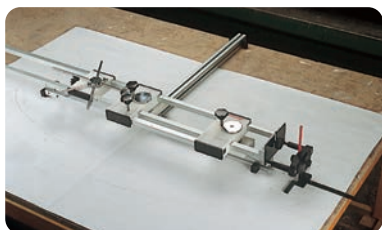

Item

ELLISYSTEM
“ELLISYSTEM” is the “last born” of our special equipments for producing arch frames. With **“ELLISYSTEM”** the customer can execute a perfect geometrical ellipse. Suitable for house restoration where the double radius arch is difficult to fit. Simple and easy to use, it keeps the same work procedure and features as **“ARKADE” + “ELLIX”**

Watch the Video on
YouTube



Examples of windows made with “Arkade+Zinkel+Ellix”



WORK PROCEDURE

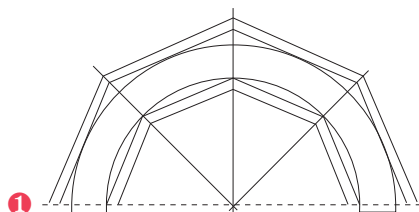

1
- Drawing of arch.
- Drawing and cutting of arch component parts.

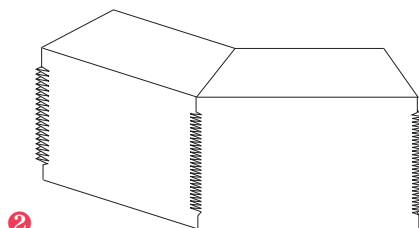

2
Joining the arch component parts
(use eccentric clamp Art. SPP060029).

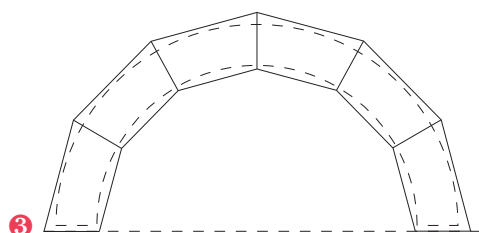

3
Positioning and securing the arch component parts,
which are glued together

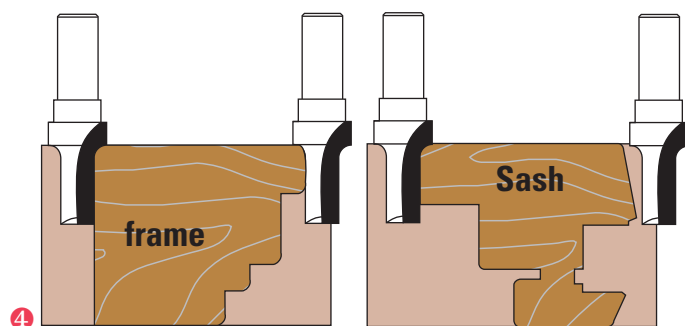

4
Inner-outer frame and sash outlining using a portable electric router fitted on the equipment
(use tool Art. E.199.200.R).

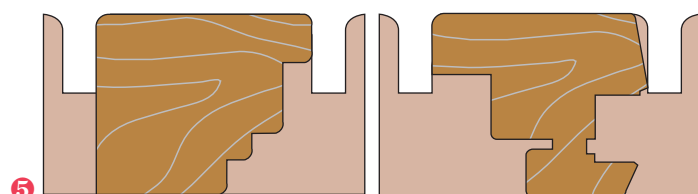

5
Using the band saw, remove excess wood

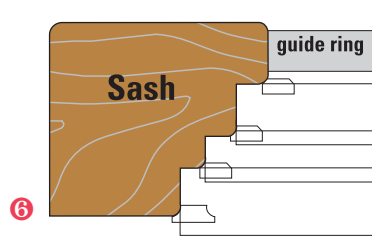

6
Profiling the frame by means of the cutter units with copy bearing on moulding machine

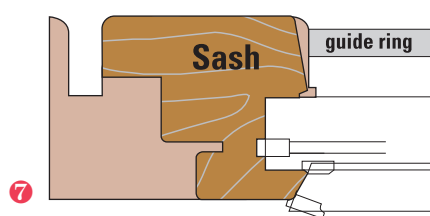

7
Profiling the sash by means of the cutter units with copy bearing on moulding machine

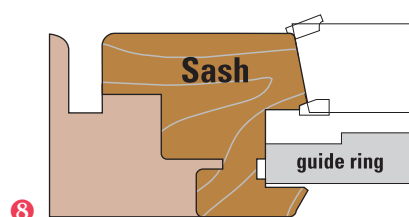

8
Profiling the glazing bead by means of the cutter units with copy bearing on moulding machine

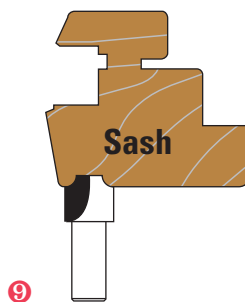

9
Shaping of the glazing bead (with cutter Art. E.199.165.R use router table Art. SPP060028 ballbearing guide Art. SPP060039).

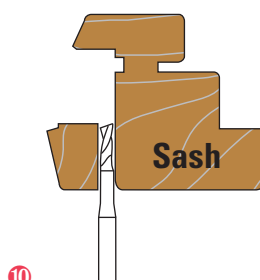

10
Separation of glazing bead with cutter Art. T141.061.R.

“ARKADE+ZINKEL+ELLIX”

The only equipment on the market capable of producing single and double radius arches or elliptical frames

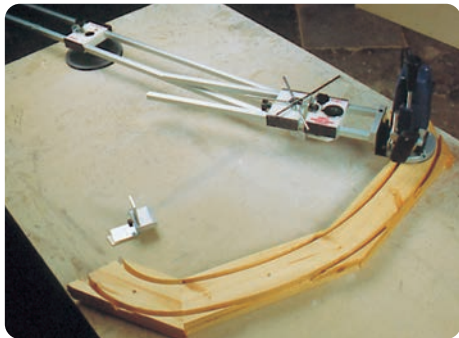

The window arch is worked continuously
It does not require a specific work bench
The goniometer shows exactly how to cut the wood sections making up the arch

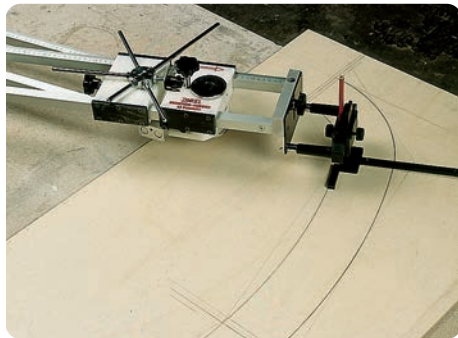

Drawing is done before making the window
A carpenter's pencil is used
Bars are engraved

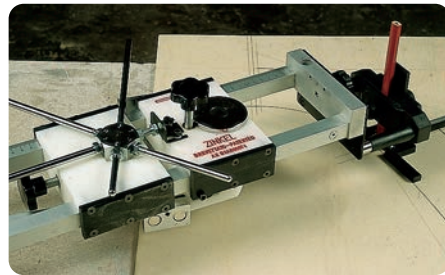

Thanks to the revolver, the frame measurements can be repeated without risk of error



With the router table accessory and the ballbearing guide the execution of glazing bead is quick and easy.

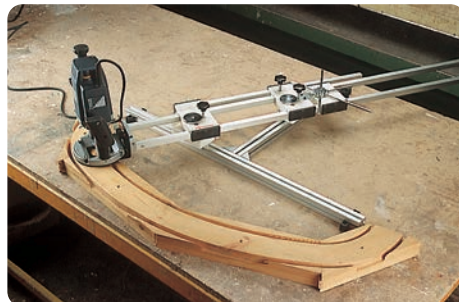

With the equipment “ELLIX” a perfect geometrical ellipse can be executed



Uses standard electric router

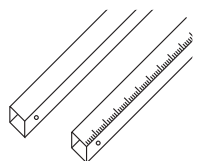

| Item | Description |
|-----------|--------------------------|
| SPP060037 | Additional 1.500 mm bars |

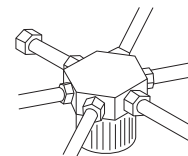

| Item | Description |
|-----------|---------------------|
| SPP060036 | Additional revolver |

TOOLS TO BE USED WITH THESE EQUIPMENTS

| Shank Ø8 | Shank Ø12 | Description | |
|-------------|------------|---|--|
| C199.140.R | E199.140.R | T.C.T. beading bit | |
| C199.165.R | E199.165.R | T.C.T. beading bit | |
| C199.200.R | E199.200.R | T.C.T. beading bit | |
| T141.061.R | T141.061.R | Solid carbide bit for glass fixing lath | |
| U211.061.R | U211.061.R | HS upcut spiral bits for aluminium | |
| | Z001.006.N | Bushing Ø 6/12 | |
| Z001.001.N | | Bushing Ø 6/8 | |
| TS140.96030 | | Profile cutter hole Ø 30/35/40 | |
| TS140.96035 | | Profile cutter hole Ø 30/35/40 | |
| TS140.96040 | | Profile cutter hole Ø 30/35/40 | |

TRIMATIC FOR HINGES

TRIMATIC are drilling jigs which allow making holes required in a single pass using a normal pillar drill or a portable electric drill. These articles are dedicated to craftsmen and hobbyists who have drilling problems when fitting hinges or positioning shelves with holes at a distance between centres of 32 mm.

The **TRIMATIC** unit with three tool-holders is suitable to make the three holes to fix the hinge in a single pass with distance between centres depending on the hinge to be fixed. Tools diameter depends on the hinge used. The central bit must have right hand rotation, the lateral bits have left hand rotation.

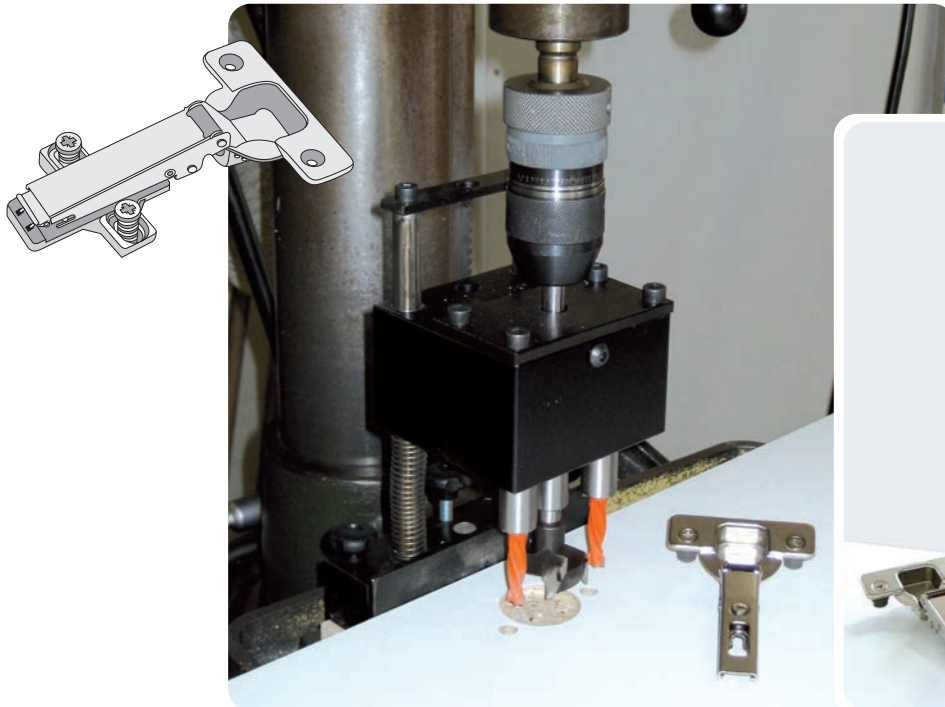

TRIMATIC 48/6 used with a pillar drilling machine



TRIMATIC 48/6 used with a portable drilling machine

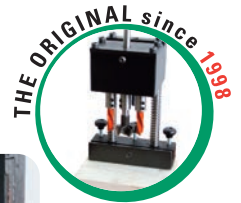

Item

TRIMATIC 38/7,5 Mini-hinges

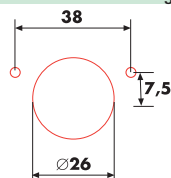

TRIMATIC 42/11 for hinges type "Grass"

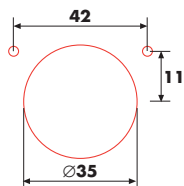

TRIMATIC 45/9,5 for hinges type "Blum"

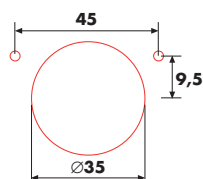

TRIMATIC 48/6 for hinges type "Salice"

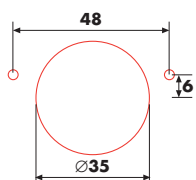

Item

TRIMATIC 48/9 for hinges type "Mepla"

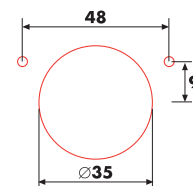

TRIMATIC 52/5,5 for hinges type "Hettich"

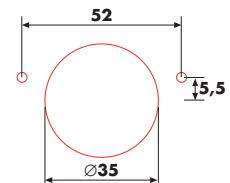

TRIMATIC 52/9 for hinges type "Hafele"

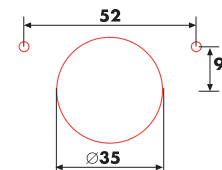

TRIMATIC 52/7,5 hinges for large thickness

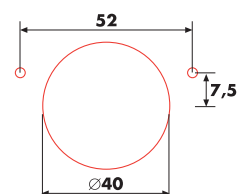

Designed in 1998 is one of the most innovative products in the woodworking field. Tested and appreciated by the most important hinges manufacturers, only our TRIMATIC boring jigs allow making more than **50.000** bores.

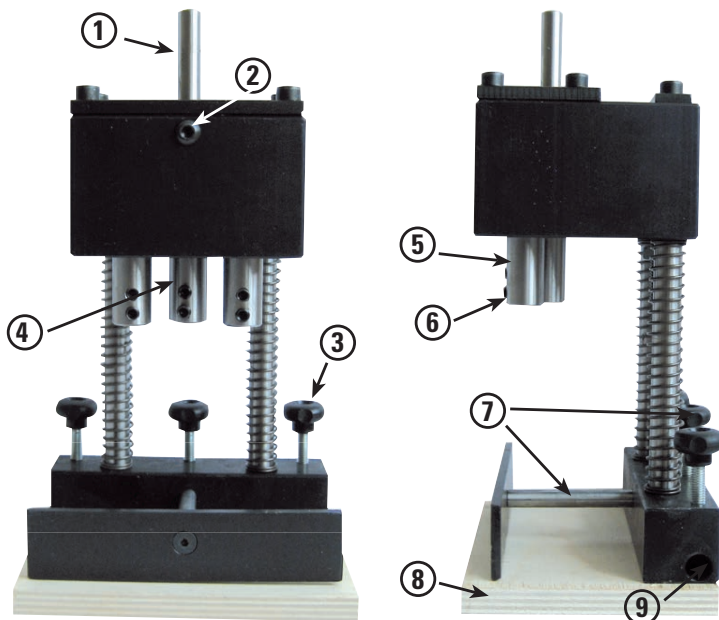

DESCRIPTION

- 1) Arbor for pillar drill spindle
- 2) Threaded hole for greasing
- 3) Locking knob for stop reference rod
- 4) Distance adjusting screw "B"
- 5) Tool holder bush
- 6) Tool locking screw
- 7) Distance adjusting screw "A"
- 8) Equipment support table
- 9) Stop rod sliding hole

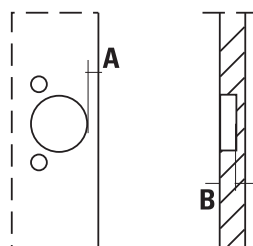

HW tools suitable for TRIMATIC

| ∅ | Description | Rotation |
|----|----------------------------|----------|
| 3 | L120.030.L + Z011.030.N | Lh |
| 5 | L103.050.L | Lh |
| 8 | L103.080.L | Lh |
| 10 | L103.100.L | Lh |
| 26 | L140.260.R | Rh |
| 35 | L140.350.R | Rh |
| 40 | L140.400.R | Rh |

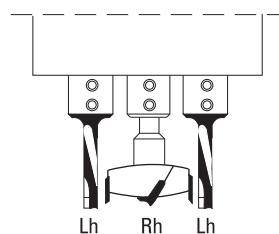

The central bit must have right hand rotation, the lateral bits have left hand rotation

DIMENSIONS

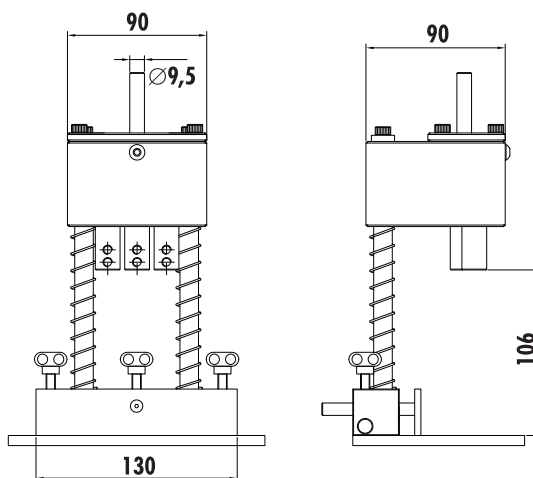

TRIMATIC 32

The **TRIMATIC** unit with five tool holders is suitable to make a five holes set with distance between centres of 32 mm in a single pass. This device is designed for drilling holes in lateral panels (sides) of furniture for both fixing the hinge and positioning the shelves at the height desired. In the **TRIMATIC 32** the tool diameters depend on the fittings used. The central bit and those mounted in the external positions have right hand rotation, the other tools have left hand rotation.

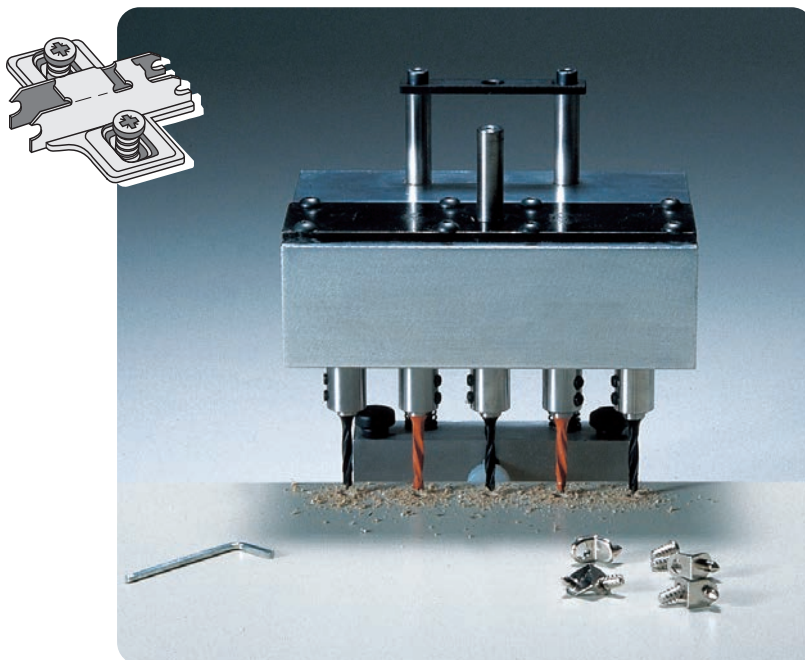

Item
TRIMATIC 32

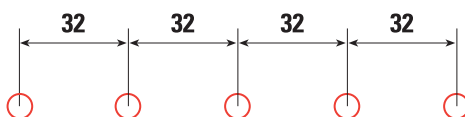

HW tools suitable for TRIMATIC 32

| Ø | Description | Rotation |
|---|-------------|----------|
| 4 | L103.040.R | Rh |
| 4 | L103.040.L | Lh |
| 5 | L103.050.R | Rh |
| 5 | L103.050.L | Lh |

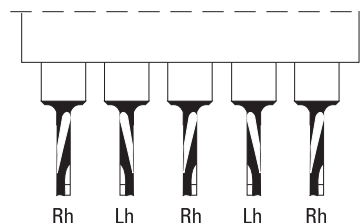

DIMENSIONS



The central bit and those mounted in the external positions have right hand rotation, the other tools have left hand rotation.

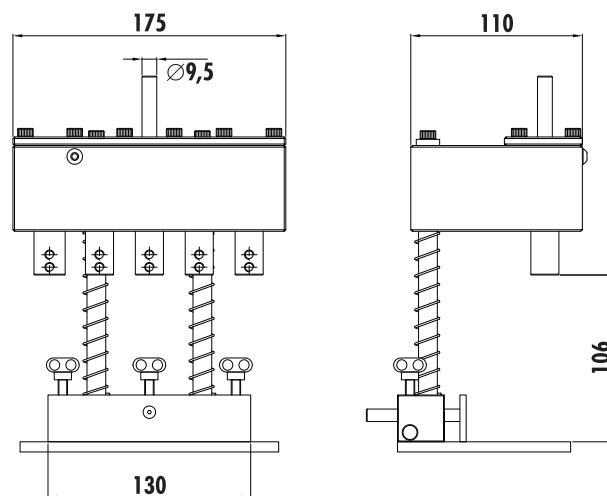

DRILLING JIG FOR CREMONE BOLTS

TRIMATIC 43/0 was designed for window frame makers who have problems with drilling holes to fit the handle on wood, wood/aluminium and PVC windows. **TRIMATIC 43/0** allows drilling the three holes necessary to fit the cremone bolt in one single pass with a normal pillar drill or a portable electric drill.

TRIMATIC 43/0, a drilling jig for handles with a distance between centres of the retaining screws of 43 mm.

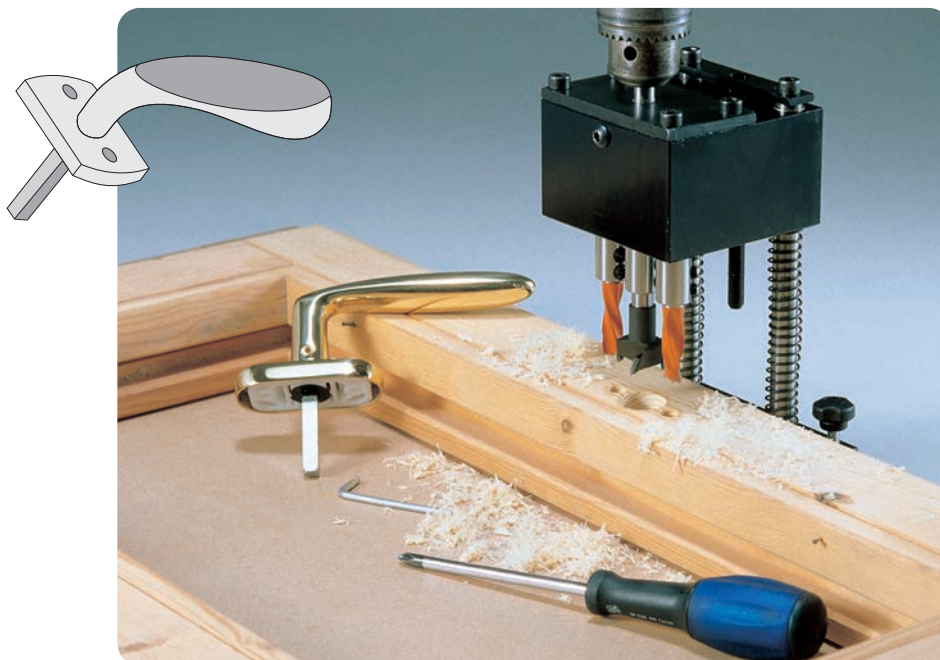

Drilling of wood and PVC window frames to fit cremone bolts

Item
TRIMATIC 43/0

HW tools suitable for TRIMATIC 43/0

| Ø | Description | Rotation |
|----|-------------|----------|
| 4 | L103.040.R | Rh |
| 4 | L103.040.L | Lh |
| 5 | L103.050.R | Rh |
| 5 | L103.050.L | Lh |
| 8 | L103.080.L | Lh |
| 10 | L103.100.R | Rh |
| 10 | L103.100.L | Lh |
| 12 | L103.120.R | Rh |
| 12 | L103.120.L | Lh |
| 25 | L140.250.R | Rh |
| 26 | L140.260.R | Rh |

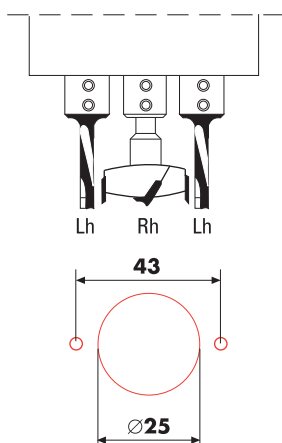

HSS tools suitable for TRIMATIC 43/0 for working PVC and Aluminium

| Ø | Description | Rotation |
|----|-------------|----------|
| 8 | U260.080.L | Lh |
| 10 | U260.100.L | Lh |
| 12 | U260.120.R | Rh |
| 12 | U260.120.L | Lh |
| 14 | U260.140.R | Rh |

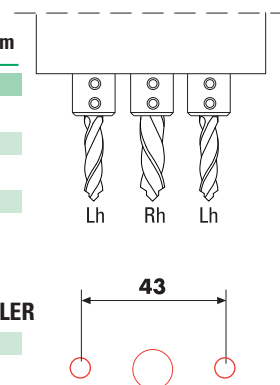

Some examples of drilling patterns

| SIEGENIA-TRIAL | | WEIDTMANN-KURLER | |
|----------------|---|------------------|---|
| U260.120.L | 2 | U260.100.L | 2 |
| U260.120.R | 1 | U260.140.R | 1 |

| G-U JET77 | | OLIVEN | |
|------------|---|------------|---|
| U260.100.L | 2 | U260.080.L | 2 |
| U260.120.R | 1 | U260.140.R | 1 |



The central bit must have right hand rotation, the lateral bits have left hand rotation.

DIMENSIONS

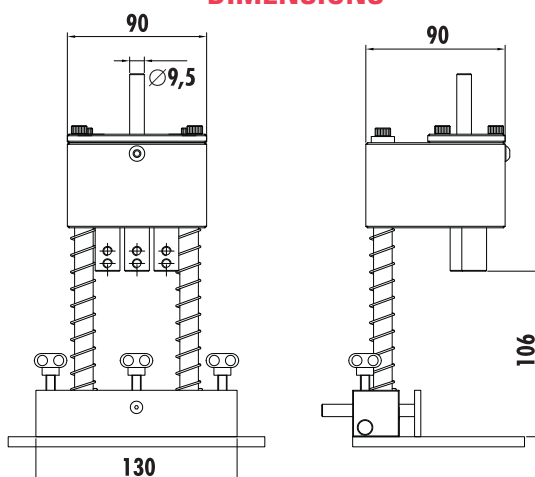

SPECIAL DEVICES FOR ANGULAR HINGES INSERTING

With constant attention paid to our customers' requirements and ongoing research for developing new technical solutions for helping craftsmen and small firms, our special equipments **TRIMATIC 22, 25 e 28** help the window makers to make holes for angular hinges to be mounted on windows and door-windows, in wood and wood-aluminium material. The **TRIMATIC 22, 25 e 28** can be used either with pillar drills or portable electric drills, and have distance between holes suitable for angular hinges of the following types: Siegenia (Trimatic 22), GU (Trimatic 25), Maico and AGB (Trimatic 28).



Fixing of edge hinge



Fixing of top hinge



Item

TRIMATIC 22 for angular hinges "SIEGENIA" (Ø30 and Ø34) with a distance between holes of 22 mm

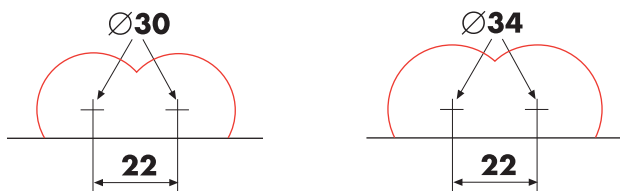

TRIMATIC 25 for angular hinges "GU" with a distance between holes of 25 mm

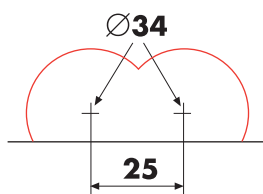

TRIMATIC 28 for angular hinges MAICO (type "Trend") and AGB with a distance between holes of 28 mm

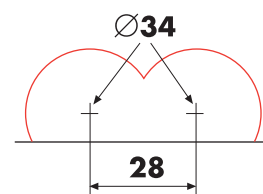

Mount the right-hand rotation bit on the bush related to the drill spindle and the left-hand rotation bit on the other bush.

DIMENSIONS

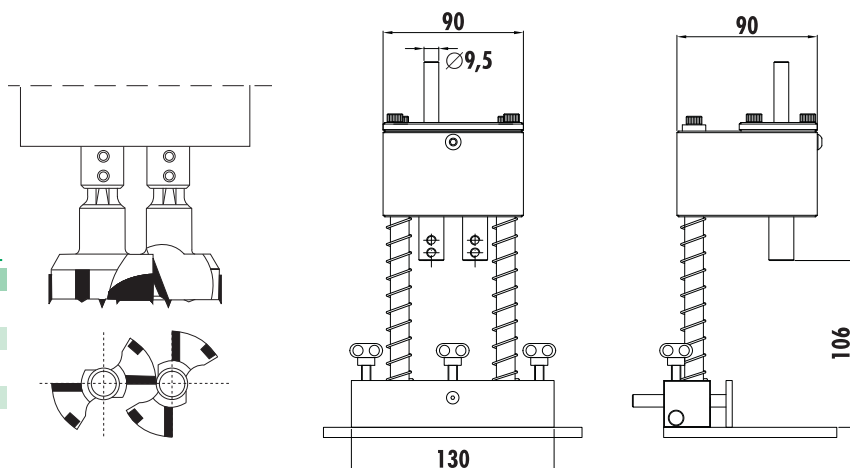

HW tools suitable for TRIMATIC 22 - 25 - 28

| Ø | Description | Rotation |
|----|-------------|----------|
| 30 | L160.300.R | Rh |
| 30 | L160.300.L | Lh |
| 34 | L160.340.R | Rh |
| 34 | L160.340.L | Lh |

TRIMATIC 22,4 FOR "LAMELLO® CABINEO®"

SISTEMI has always paid special attention to the demands of woodworkers and their issues in the woodworking. For this reason, we have developed Trimatic 22,4: the new and only drilling jig on the market that can drill the required three blind holes for mounting **Lamello® Cabineo®** furniture connection, in a single pass simply using a power portable drill or stationary pillar drill. It is especially thought for hobbyists, artisans and craftsmen who do not own CNC router machines.



Watch the Video on
YouTube



Item
TRIMATIC 22,4 **NEW**

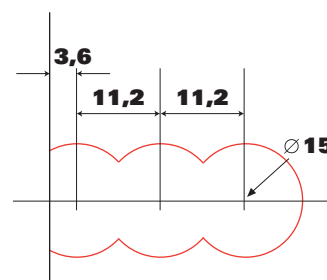
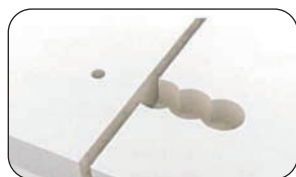

HW tools suitable for TRIMATIC 22,4, for "Lamello® Cabineo®" (not included)

| Ø | Description | Rotation |
|-----------------------|-------------|----------|
| L174.150.R NEW | Ø 15x35 | Rh |
| L174.150.L NEW | Ø 15x35 | Lh |



L174.150.R



L174.150.L (x2)

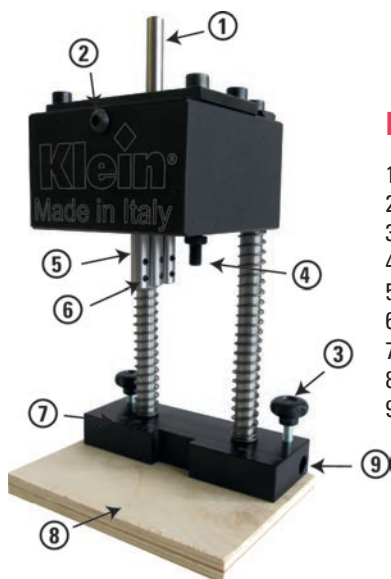
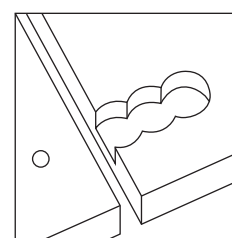

DESCRIPTION

- 1) Arbor for pillar drill spindle
- 2) Threaded hole for greasing
- 3) Locking knob for stop reference rod
- 4) Threaded screw for depth adjustment
- 5) Tool holder bush
- 6) Tool locking screw
- 7) Basement with millimetric scale
- 8) Equipment support table
- 9) Stop rod sliding hole

DIMENSIONS

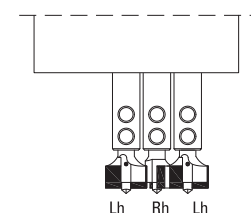
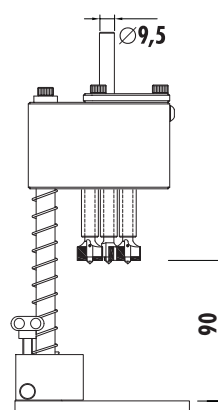

The central bit must have right hand rotation, the lateral bits have left hand rotation



The special millimetric scale on the basement will help you to make the 5 mm hole in the corresponding workpiece to tighten the screw of Cabineo® with accuracy

Cabineo® is a product of



DRILLING JIG FOR MAKING HOLES FOR HINGE INSERTING

The **TRIMATIC SUPER** is a very innovative drilling jig, suitable to solve many problems to craftsmen and small industries when fitting the hinges and handles on doors, windows and cabinet doors. The **TRIMATIC SUPER** can be easily and quickly mounted on the multi-spindles head of any automatic boring machine with 32 mm distance between centres chucks. The **TRIMATIC SUPER** is very precise and fast, making in one single pass the three holes required for fitting the hinges on the cabinet doors.

At the moment, 8 types **TRIMATIC SUPER** in different patterns are available, suitable for the most common hinges: Salice, Blum, Hettich, Grass, Mepla, Ferrari, ecc. The new model 43/0, is now available for the execution of the holes necessary to fit the cremone bolt on the handles of doors and windows. The **TRIMATIC SUPER** are small-sized, 12,5x5x3 cm, but they are very solid and long-lasting devices. The diameter of the drills has to be chosen with reference to the model of hinges being used. Now, just choose the type of **TRIMATIC SUPER** you need.

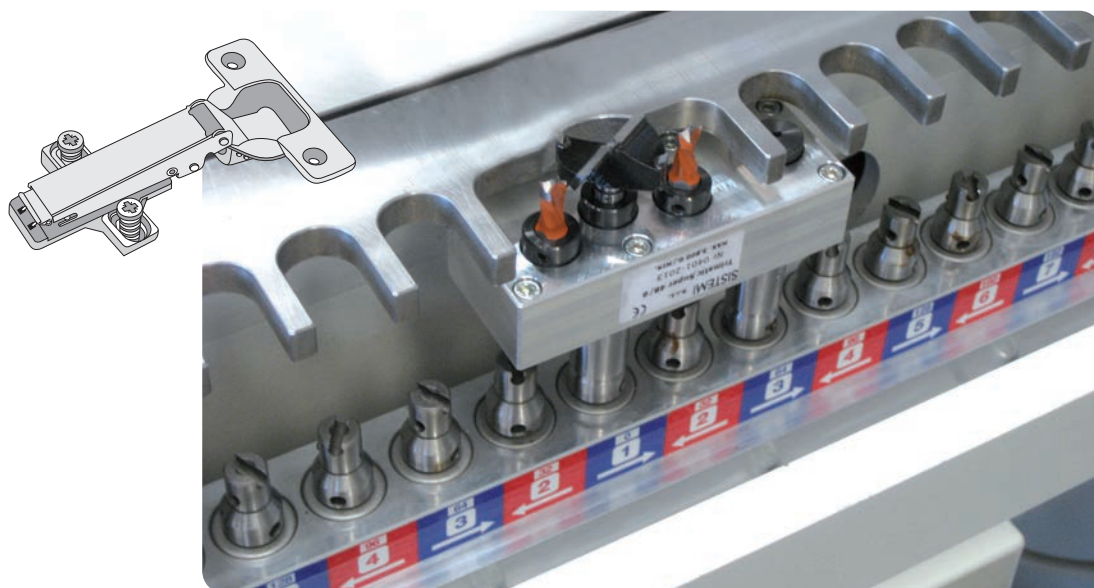

Item
TRIMATIC SUPER 38/7,5 Mini-hinges

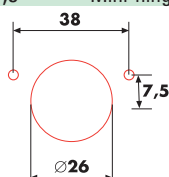

TRIMATIC SUPER 42/11 for hinges type "Grass"

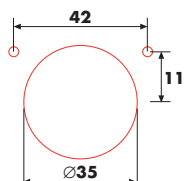

TRIMATIC SUPER 45/9,5 for hinges type "Blum"

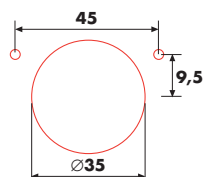

TRIMATIC SUPER 48/6 for hinges type "Salice"

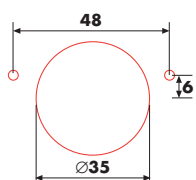

Item
TRIMATIC SUPER 48/9 for hinges type "Mepla"

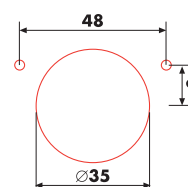

TRIMATIC SUPER 52/5,5 for hinges type "Hettich"

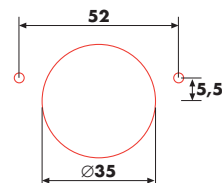

TRIMATIC SUPER 52/9 for hinges type "Hafele"

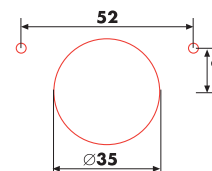

TRIMATIC SUPER 52/7,5 hinges for large thickness

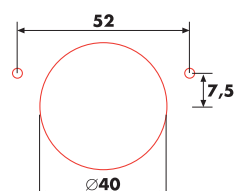

DRILLING JIG FOR MAKING HOLES FOR HINGE INSERTING



HW tools suitable for TRIMATIC SUPER

| Ø | Description | Rotation |
|----|----------------------------|----------|
| 3 | L120.030.L + Z011.030.N | Lh |
| 5 | L171.050.L | Lh |
| 8 | L171.080.L | Lh |
| 10 | L171.100.L | Lh |
| 26 | L170.260.R | Rh |
| 35 | L170.350.R | Rh |
| 40 | L170.400.R | Rh |

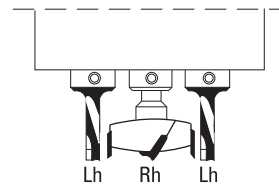

DIMENSIONS

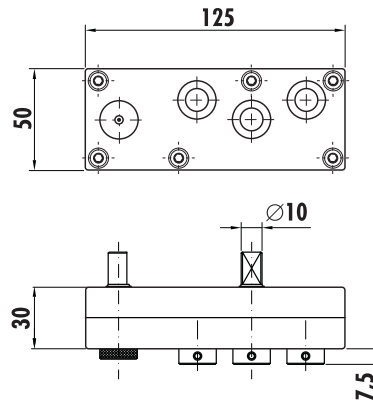

The central bit must have right hand rotation, the lateral bits have left hand rotation.

DRILLING OF WOOD AND PVC WINDOW FRAME TO FIT CREMONE BOLT

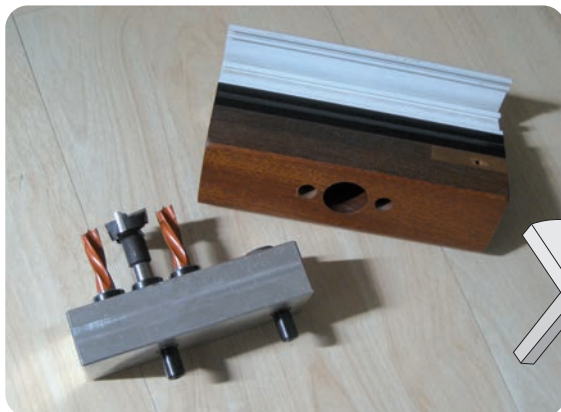

| Item |
|---------------------|
| TRIMATIC SUPER 43/0 |

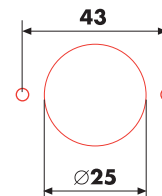

HW tools suitable for TRIMATIC SUPER 43/0

| Ø | Description | Rotation |
|----|-------------|----------|
| 10 | L103.100.L | Lh |
| 12 | L103.120.L | Lh |
| 25 | L140.250.R | Rh |

TRIMATIC SUPER 22,4 FOR "LAMELLO® CABINEO®"

The new **TRIMATIC SUPER 22,4** allows to drill at the same time the three holes perpendicular to the machine boring axis suitable for mounting Cabineo® connections.



TRIMATIC SUPER 22,4 drilling jig for multi spindles machines

HW tools suitable for **TRIMATIC SUPER 22,4**

| S Ø 6 | Description | Rotation |
|-----------------------|-------------|----------|
| L174.150.R NEW | Ø 15x35 | Rh |
| L174.150.L NEW | Ø 15x35 | Lh |

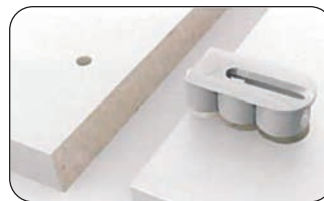
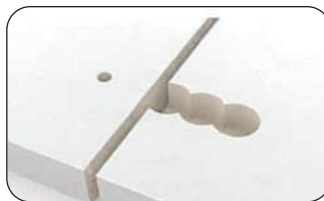
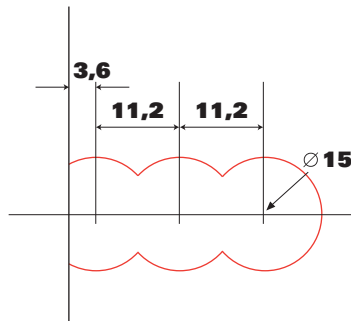

| Item |
|--------------------------------|
| TRIMATIC SUPER 22,4 NEW |

DIMENSIONS

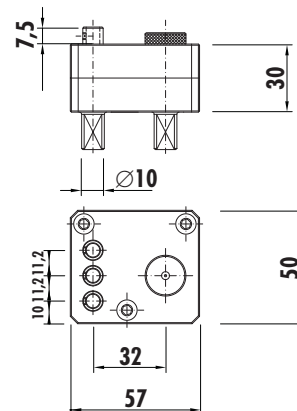

DRILLING JIG FOR MAKING HOLES FOR HINGE INSERTING

TRIMATIC SUPER 32/90° allows to drill at the same time 2 holes perpendicular to the machine boring axis.

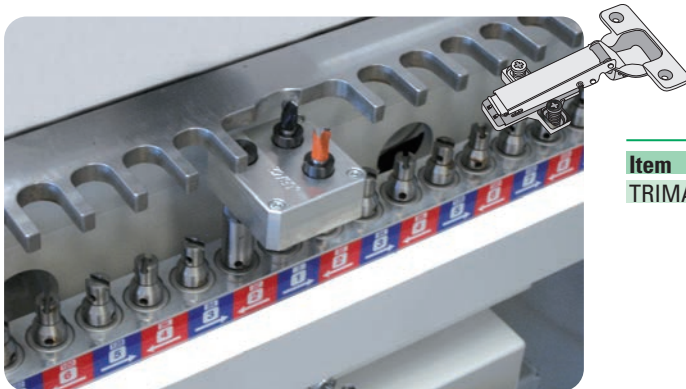
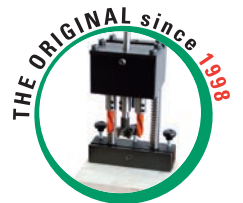

TRIMATIC SUPER 32/90° drilling jig for multi spindles machines 32 mm

HW tools suitable for **TRIMATIC SUPER 32/90°**

| Ø | Description | Rotation |
|----|-------------|----------|
| 20 | L170.200.L | Lh |
| 10 | L171.100.R | Rh |

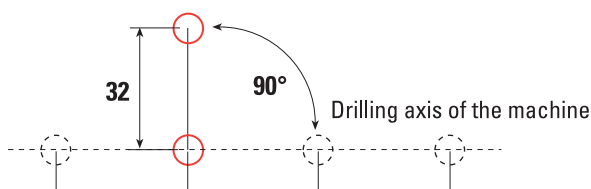

| Item |
|-----------------------|
| TRIMATIC SUPER 32/90° |

DIMENSIONS

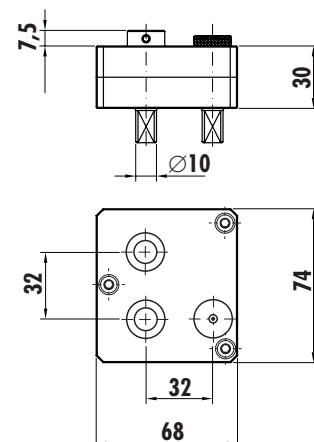

ECCENTRIC CLAMP

The eccentric clamp is suitable for keeping the glued wood sections with comb joints under pressure. It is tightened and slackened by turning the grip; the eccentric pressors are covered in rubber to prevent damage to the wood.

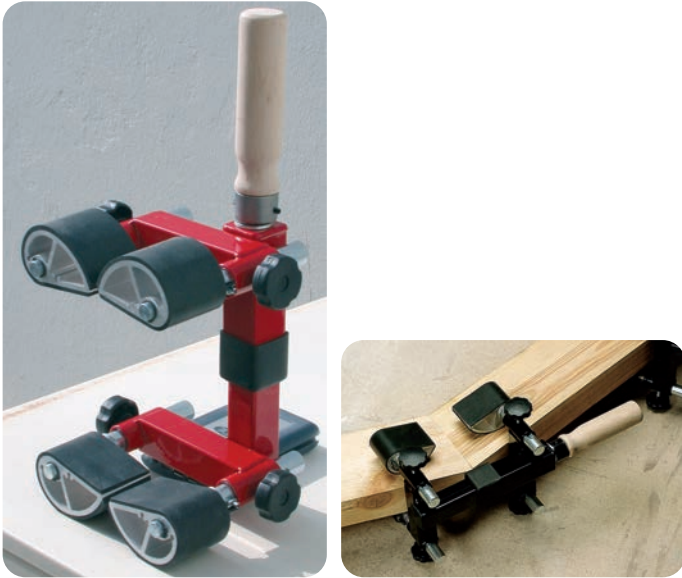

| Item | Thickness range |
|-----------|-------------------------|
| SPP060029 | Min. 25 mm - Max 75 mm |
| SPP060053 | Min. 65 mm - Max 110 mm |

DRIVER FOR CURVES

The driver for curves was conceived for greater safety during router machining on curves. It is equipped with a motor sufficient to guarantee a regular feed of about 2 m/min. so that a good quality of finish is obtained. The rubber wheel, apart from not damaging the wood, guarantees the perfect position of the piece with respect to the tools. The driver can already be applied with an arc of 25 cm radius.

2 feed rates=1,39 mt/min. + 2,78 mt/min.

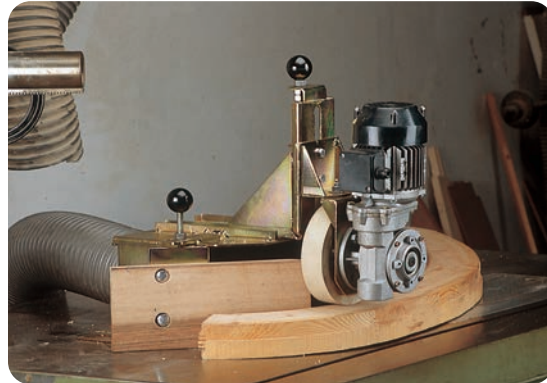

| Item | Description |
|-----------|--------------------------------|
| SPP060065 | Drivers for curves 2 feed rate |

ROUTER TABLE



| Item | Description |
|-----------|--|
| SPP060028 | Router table to separate the glass fixing lath |
| SPP060039 | Ball bearing guide for router table |

LIFTING CLAMP

The lifting clamp facilitates the handling and transport of large panels. It features an anatomic wooden grip and rubber covered eccentric jaws.



| Item | Thickness range |
|-----------|------------------------|
| SPP060047 | Min. 10 mm - Max 65 mm |

EDGE CLAMP

The edge clamp is used to press the wooden lippings against the edge of the panel. The eccentric pressors are covered in rubber. This article is practically indispensable when gluing edge on curved or shaped panels.

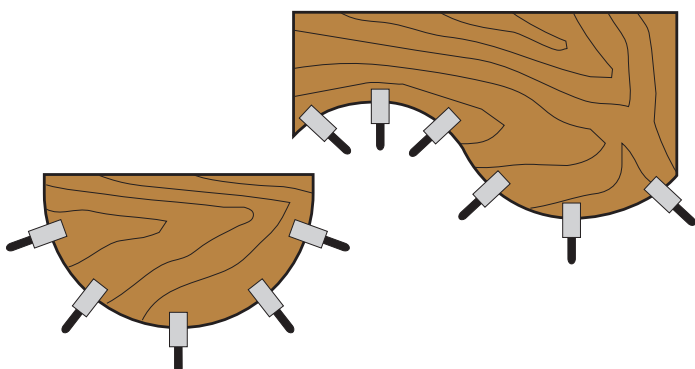

| Item | Thickness range |
|-----------|------------------------|
| SPP060052 | Min. 10 mm - Max 65 mm |

T-JOINTS CLAMP

Suitable for T-joints in little pieces of furniture

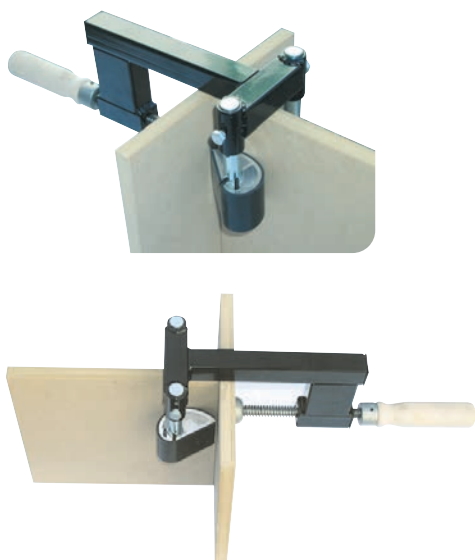

| Item | Thickness range |
|-----------|------------------------|
| SPP060075 | Min. 10 mm - Max 65 mm |

CARPENTER'S CLAMP

The carpenter's clamp is suitable for craftsmen who manufacture modern furniture. The clamp is tightened and loosened by turning the wooden handgrip. The ends which hold the panel are covered with ribbed rubber to protect and improve the grip. With a suitable number of extensions furniture of any dimension can be assembled.



| Item | Thickness range |
|-----------|--------------------------|
| SPP020021 | Min. 250 mm - Max 800 mm |

EXTENSIONS

| Item | Thickness range |
|-----------|-----------------|
| SPP020022 | 800 mm |

DOOR LIFTER

Lifts, swivels and lowers. Easy foot operation for weights up to 100 kg for the installation of doors including fire doors, windows, furniture, dry walls, partitions.



| Item |
|-----------|
| LIFTER100 |

QUICK CLAMPING DEVICES

Devices for quick clamping workpieces and for numerous applications. By simply applying pressure on the grip, once dead centre has been passed, they close securely. Horizontal models with horizontal or vertical clamping, push rod and pneumatic. Maximum quality and a virtually unlimited lifespan.



HORIZONTAL TYPE WITH HORIZONTAL CLAMPING

ART. B.ORI



| Item | Clamping strength |
|------------|-------------------|
| B.ORI.0240 | Kg. 120 |
| B.ORI.0400 | Kg. 200 |
| B.ORI.0600 | Kg. 300 |
| B.ORI.0700 | Kg. 350 |

HORIZONTAL TYPE WITH VERTICAL CLAMPING

ART. B.VER



| Item | Clamping strength |
|------------|-------------------|
| B.VER.0241 | Kg. 120 |
| B.VER.0401 | Kg. 200 |
| B.VER.0601 | Kg. 300 |
| B.VER.0701 | Kg. 350 |

PNEUMATIC TYPE

ART. B.PNE



Operated by a cylinder 6,5 Atm.

| Item | Clamping strength |
|------------|-------------------|
| B.PNE.0400 | Kg. 200 |

PUSHER TYPE

ART. B.SPI



| Item | Clamping strength |
|------------|-------------------|
| B.SPI.0400 | Kg. 220 |

SPARE ENDPINS

ART. B.PUNTALE



SPARE ENDPINS made in rubber

| Item | Description |
|----------------|--------------------|
| B.PUNTALE.0240 | M6 for B.ORI.0240 |
| B.PUNTALE.0400 | M8 for B.ORI.0400 |
| B.PUNTALE.0600 | M10 for B.ORI.0600 |
| B.PUNTALE.0700 | M12 for B.ORI.0700 |

KleinWASHER Automatic Tool Washer



Sealants, lubricants,
cleaning products
see section 14 page 14.03

- Suitable for washing any metal parts and tools from the industry to the smaller workshop
- For tools of various dimensions, also for tool groups for windows thanks to its rotating tank with a height of 350 mm
- Heated biological operating mode
- To be used only with water-based detergent (see our item **KleinCLEANUP**)

Includes:

- Stainless steel housing • Rotating tank D=600 mm • Tank's capacity: 75 L
- Maximum payload: 100 kg • Maximum height of the tools: 350mm
- Stainless steel upper, under and lateral washing arms • Timer
- Thermal resistance • Single-phase 1 hp pump • Dimensions: 940x790 h930 mm
- Dimensions packing: 1210x1050 h1200 mm • Weight: 65 kg

| Item | Description |
|-------------|-----------------------|
| KLEINWASHER | Automatic tool washer |

SHRINK FIT UNIT

ART. K.START.2



- Heating time from 2 to 7 seconds
- Provided with inductor stop rings (6 to 12) + (14 to 20) and chuck holder for HSK63F
- Heating located on the tool holder, no deterioration of the tool and tool holder
- Self-regulated power thanks to a microprocessor depending on parameters detected
- Inductor rotates 180° without disassembling
- Power supply 3x380/480V – 16A 50/60 Hz -14 kW
- Dimensions: L= 255 mm - D= 490 mm - H= 755 mm
- Weight (options excluded) 20 kgs

NB:
This items cannot be sold in Germany/France/USA due to commercial agreements between the producer (Elco) and their autorised dealers in these markets.

| Item |
|----------------------|
| K.START.2 NEW |

KleinCLEANER Manual Tool Washer



Sealants, lubricants,
cleaning products
see section 14 page 14.03

- Can wash any type of tools or metal parts
- Easy to be used with water and spray gun
- Heated biological operating mode

Includes:

- Spray gun
- Tool holding grid
- Stainless steel tank with thermal resistance
- Air-operated double diaphragm pump 5 L/min
- Tank dimensions: 600x500 h 250 mm
- Tank capacity: 70L
- Dimensions: 700x560 h1000 mm
- Dimensions packing: 970x670 h1020
- Weight: 30 Kg

| Item | Description |
|--------------|--------------------|
| KLEINCLEANER | Manual tool washer |

COOLING UNIT WITH AIR FLOW

ART. K.FG500



- Air cooling unit for shrink fit chucks
- Cooling time from 1,30 minute to 3 minutes
- Provided with cooling stop rings (6 to 12) + (14 to 20) and chuck holder for HSK63F
- Compressed air supply: 4-6 bars
- Dimensions: L= 220 mm - D= 190 mm - H= 615 mm
- Weight: 5 kgs

NB:
This items cannot be sold in Germany/France/USA due to commercial agreements between the producer (Elco) and their autorised dealers in these markets.

| Item |
|--------------------|
| K.FG500 NEW |

ANGLE HEADS FOR CNC ROUTING MACHINES

For a quotation on a model not present in this catalogue, please specify:

Type of Machine and model - Type of tool holder (HSK, ISO etc.) - N° of tool exits - Tool used - Application and material to be processed

CNC Aggregate With One Exit Type MONO 90° Function line

ART. GR2.WS.FL

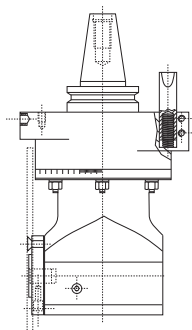

FUNCTION LINE. CNC Aggregate With One Exit

GREASE LUBRICATION

High performance in continuous operation with highest operator ease: these are the features of the aggregates of the FUNCTION LINE.
For Boring, Routing, and Sawing.

Technical Data:

- Machine connection per request
- Speed max.: 10,000 R.P.M. (drive)
- Speed max.: 15,000 R.P.M. (tool spindle)
- Gear ratio i= 1:1,5 - Torque max.: 20 Nm
- Temperature max.: 85° C / 185° F
- Tool interfaces: Collet ER 25, collet ER 32, saw blade connection with flange 30 mm and pitch circle 45 mm, alternatively 52 mm
- In conventional design or alternatively available with modular tool clamping system
- Rotating direction left or right
- Spindle rotating direction same as drive rotating direction
- Position of tool spindle 90°
- Aggregate can be rotated 360° around drive.

Accessories included:

- Collet nut for ER25 - Hook spanner
- 4 torx screws to fix the saw blade to the connection

CNC Aggregate With Two Exits Type DUO

ART. GR2.WZ.FL

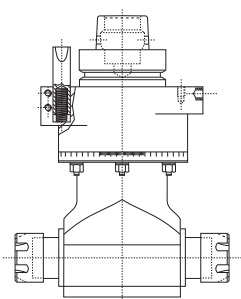

FUNCTION LINE. CNC Aggregate With Two Exits

GREASE LUBRICATION

High performance in continuous operation with highest operator ease: these are the features of the aggregates of the FUNCTION LINE. For Boring, Routing, and Sawing.

Technical Data:

- Machine connection per request - Speed max.: 10,000 R.P.M. (drive)
- Speed max.: 15,000 R.P.M. (tool spindle) - Gear ratio i: 1:1,5
- Torque max.: 20 Nm - Temperature max.: 85° C
- Tool interfaces: Collet ER 25, collet ER 32, saw blade connection with flange 30 mm and pitch circle 45 mm, alternatively 52 mm
- In conventional design or alternatively available with modular tool clamping system
- Rotating direction left or right
- Spindle rotating direction same as drive rotating direction – one tool running same direction, one tool opposite
- Position of tool spindle 90°
- Aggregate can be rotated 360° around drive

CNC Aggregate With Four Exits Type QUATTRO

ART. GR2.WV.FL

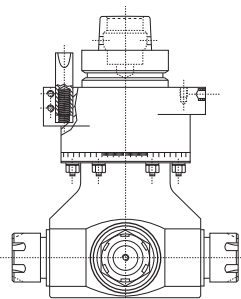

FUNCTION LINE. CNC Aggregate With Four Exits

GREASE LUBRICATION

High performance in continuous operation with highest operator ease: these are the features of the aggregates of the FUNCTION LINE. For Boring, Routing.

Technical Data:

- Machine connection per request
- Speed max.: 10,000 R.P.M. (drive)
- Speed max.: 15,000 R.P.M. (tool spindle)
- Gear ratio i: 1:1,5 - Torque max.: 20 Nm
- Temperature max.: 85° C
- Tool interfaces: collet ER 25 / ER 32, 2 x boring and 2 x routing
- Rotating direction left or right
- Spindle rotating direction same as drive rotating direction – three tools running same direction, one tool opposite direction
- Position of tool spindle 90°
- Aggregate can be rotated 360° around drive

CNC Aggregate With Adjustable Angle And Digital Display - Type VARIO VISO

ART. GR2.WD.FL

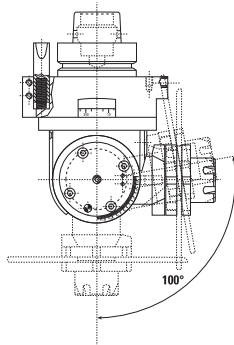

FUNCTION LINE. CNC Aggregate With Adjustable Angle And Digital Display GREASE LUBRICATION

High performance in continuous operation with highest operator ease: these are the features of the aggregates of the FUNCTION LINE. For Boring, Routing, and Sawing.

Technical Data:

- Machine connection per request - Speed max. 15,000 R.P.M. (drive)
- Speed max. 15,000 R.P.M. (tool spindle) - Gear ratio i 1:1
- Torque max. 20 Nm - Temperature max. 85° C / 185° F
- Angle adjustment 0 – 100°
- Tool interfaces: Combination connection ER 25, saw blade or saw blade connection flange 30 mm and pitch circle 45/52 mm with integrated Weldon connection diameter 10 mm
- Rotating direction left or right
- Spindle rotating direction opposite drive rotating direction
- Version with one single clamping screw and digital display of adjusted angle with conical pin for 0° reference adjustment
- Aggregate can be rotated 360° around drive

CNC Aggregate For The Machining Of Panels From Underneath - Type SOTTO

ART. GR2.W1.FL

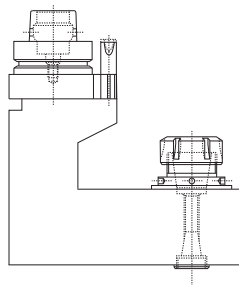

FUNCTION LINE. CNC Aggregate With One Exit From Underneath GREASE LUBRICATION

High performance in continuous operation with highest operator ease: these are the features of the aggregates of the FUNCTION LINE.

Technical Data:

- Machine connection per request
- Speed max. 15,000 R.P.M. (drive)
- Speed max. 15,000 R.P.M. (tool spindle)
- Gear ratio i 1:1
- Torque max. 15 Nm
- Temperature max. 85° C / 185° F
- Tool interface cylindrical 10 mm
- Rotating direction left or right
- Aggregate can be rotated 4 x 90° around drive
- Cycle operation required!

CNC Aggregate Vertical Version With Multiple Spindles In Line - Type VERTI-LINE

ART. GR2.W2.FL

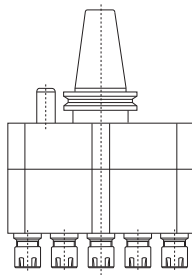

FUNCTION LINE. CNC Aggregate Vertical Version With Multiple Spindles In Line GREASE LUBRICATION

High performance in continuous operation with highest operator ease: these are the features of the aggregates of the FUNCTION LINE. For Boring and Light Duty Routing Operations.

Technical Data:

- Machine connection per request
- Speed max. 10,000 R.P.M. (drive)
- Speed max. 10,000 R.P.M. (tool spindle)
- Gear ratio i 1:1
- Torque max. 15 Nm (drive)
- Temperature max. 85° C / 185° F
- Tool interfaces ER 16 Mini, Weldon 10 mm
- Rotating direction left or right - Rotating direction spindles alternating left/right
- Aggregate can be rotated 360° around drive
- Amount of spindles variable, depending on motor spindle and collision dimensions
- Available with different patterns for hinges etc.

CNC Aggregate With One Exit Type MONO With Oil Lubrication

ART. GR3.WS.UL

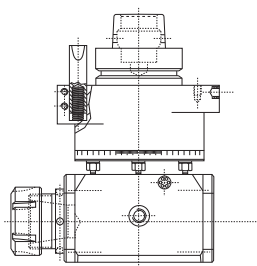

ULTRA LINE. CNC Aggregate With One Exit [90°]

OIL BATH LUBRICATED

No compromises! The aggregates of the ULTRA LINE have been designed for extreme applications in continuous operation, for the use with critical material and for highest loads. Ideal for the use with a large Diameter Saw Blade or a Rough Milling Tool. Using the Optimum Motorspindle Torque and the Optimum Saw Blade/Tool Speed. For Boring, Routing and Sawing.

Technical Data:

- Machine connection per request
- Speed max.: 10,000 R.P.M. (drive)
- Speed max.: 15,000 R.P.M. (tool spindle)
- Gear ratio i: 1:1,5
- Torque max.: 20 Nm
- Temperature max.: 85° C / 185° F
- Tool interfaces: Collet ER 25, collet ER 32, saw blade connection with flange 30 mm and pitch circle 45 mm, alternatively 52 mm
- In conventional design or alternatively available with modular tool clamping system
- Rotating direction left or right
- Spindle rotating direction same as drive rotating direction
- Position of tool spindle 90°
- Aggregate can be rotated 360° around drive

CNC Aggregate With Two Exits Type DUO With Oil Lubrication

ART. GR3.WZ.UL

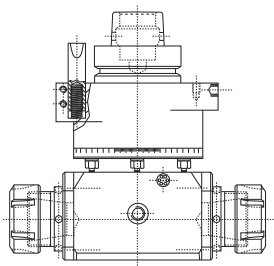

ULTRA LINE. CNC Aggregate With Two Exits

OIL BATH LUBRICATED

No compromises! The aggregates of the ULTRA LINE have been designed for extreme applications in continuous operation, for the use with critical material and for highest loads. For Boring, Routing and Sawing.

Technical Data:

- Machine connection per request
- Speed max.: 10,000 R.P.M. (drive)
- Speed max.: 15,000 R.P.M. (tool spindle)
- Gear ratio i: 1:1,5
- Torque max.: 20 Nm
- Temperature max.: 85° C
- Tool interfaces: Collet ER 25, collet ER 32, saw blade connection with flange 30 mm and pitch circle 45 mm, alternatively 52 mm in conventional design or alternatively available with modular tool clamping system
- Rotating direction left or right
- Spindle rotating direction same as drive rotating direction – one tool running same direction, one tool opposite
- Position of tool spindle 90°
- Aggregate can be rotated 360° around drive

CNC Aggregate With Moulder Spindle And Gear Reduction Now With Integrated Dust Exhaust Type MEGACUTTER

ART. GR3.WX.UL

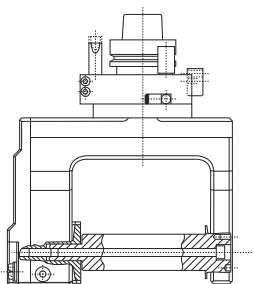

ULTRA LINE. CNC Aggregate For Moulder Knife tool

OIL BATH LUBRICATED

No compromises! The aggregates of the ULTRA LINE have been designed for extreme applications in continuous operation, for the use with critical material and for highest loads. Ideal For The Use With a Moulder Spindle or a Saw Blade Package. Using The Optimum Motorspindle Torque And The Optimum Saw Blade/Tool Speed.

Technical Data:

- Machine connection
- Speed max. 11.380 R.P.M. (drive)
- Speed max. 7,690 R.P.M. (tool spindle)
- Gear ratio i = 1:0,641
- Torque max. 20 Nm
- Temperature max. 85° C / 185° F
- Tool interfaces: arbour with 30 mm diameter, 120 clamping length
- Rotating direction left or right
- Spindle rotating direction same as drive rotating direction
- Position of tool spindle 90°
- Aggregate can be rotated 360° around drive

CNC Aggregate With Adjustable Angle Type VARIO VISO With Oil Lubrication

ART. GR3.WD.UL

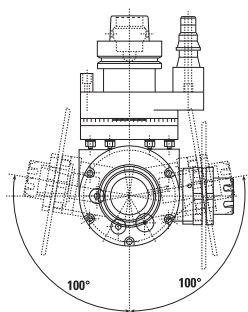

ULTRA LINE. CNC Aggregate With Adjustable Angle

OIL BATH LUBRICATED

No compromises! The aggregates of the ULTRA LINE have been designed for extreme applications in continuous operation, for the use with critical material and for highest loads. For Boring, Routing and Sawing.

Technical Data:

- Machine connection per request
- Speed max. 13.760 R.P.M (input)
- Speed max. 15.000 R.P.M (output)
- Gear ratio i 1:1,09
- Torque max. 22 Nm
- Temperature max. 85° C / 185° F
- Angle adjustment 2 x 0 – 100°
- Tool interfaces Combination connection ER 25/saw, collet connection ER 25 as well as saw blade connection with flange 30 mm, pitch circle 45 mm, alternatively 52 mm
- Rotating direction left or right
- Spindle rotating direction opposite drive rotating direction
- Adjustment regulation with nonius
- Aggregate can be rotated 360° around drive

DISPLAYS

BASE - STANDARD - PROFESSIONAL, these are the new displays **Klein** designed to have a modular system of slatted panels with two, three or four rows of hooks on which to hang products. In order to exhibit not packed items one or more shelves can be also hung. Standard and Professional displays can be supplied with sliding glass windows and locked with a safety lock. The great flexibility and visibility of the product assortment in the new displays improve the offer range and thus the service to customers.



Klein®

Counter display units



Adjustable countersinks
art. **A199**



Magnetic aligners for
planer knives
art. **Y200**



Diamond whetstones **DMT**
art. **A4**
art. **F70 - FW - FF - FS**
art. **W4/6/8 - WM - WS - WT**



Display art. **S180.017.N**
includes 17 pcs.
hole saws



Display art. **S180.011.N**
includes 11 pcs.
hole saws

Display **MIX**
n. 6 Assorted spray cans
2 pcs. **Klein DRYUP**
2 pcs. **Klein TOPUP**
2 pcs. **Klein PROTECT**



Also available:
Display **Klein DRYUP**
n. 6 spray cans
Display **Klein TOPUP**
n. 6 spray cans
Display **Klein PROTECT**

BASE

1 modular panel

Small display, ideal for starting with a basic assortment
Dimensions (cm): 110 (L) x 90 (H) x 30 (P)

Display customizable



Display code **Base 01** includes:
 Router bits S=6/8 for portable routers
60 positions



Display code **Base 02** includes:
 Router bits S=12 for portable routers
30 positions



Display code **Base 03** includes:
 Router bits for Elu machines code **F101**
 "Forstner" bits code **R213**
 Hinge boring bits code **R111**



Display code **Base 04** includes:
 Insert router bits "Novasystem"

SOME MORE EXAMPLES OF DISPLAYS "BASE"



Mortising bits code **S202**
 Diamond whetstones **DMT**



Circular saw blades for portable saws

STANDARD

2 modular panels

Consisting of two displays "BASE", can be composed according to customers' needs.
Suitable for those who want a good variety of products waiting to increase and improve the offer range.

Dimensions (cm): 110 (L) x 145 (H) x 36 (P)

Display code **Standard 01**
includes:
Router bits S=6/8 for portable routers
120 positions

**Display
customizable**

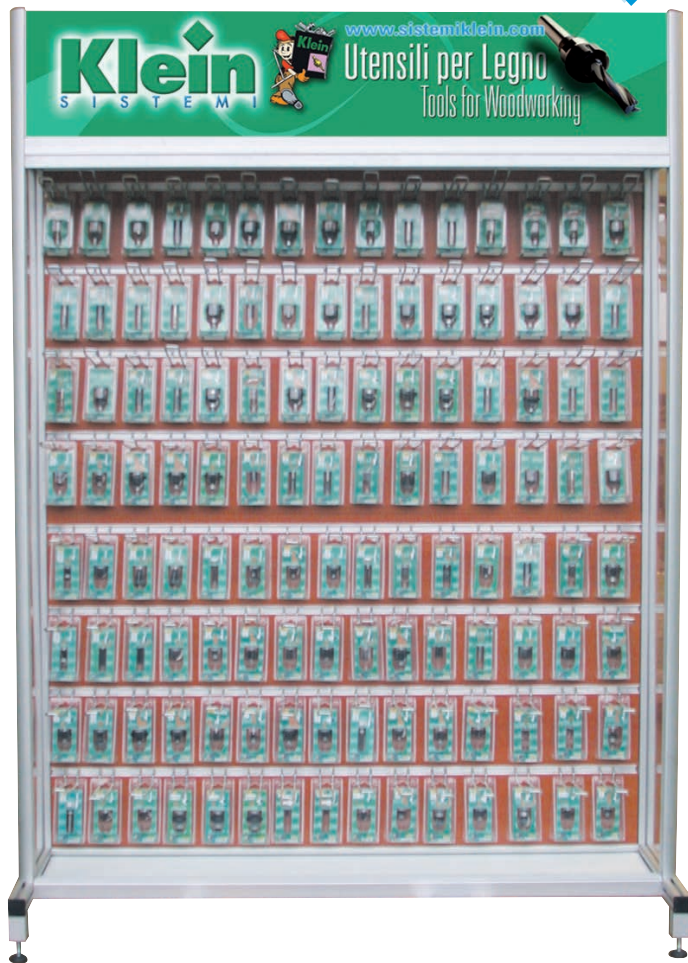

Display code **Standard 02**
includes:
Router bits S=12 for portable routers
60 positions

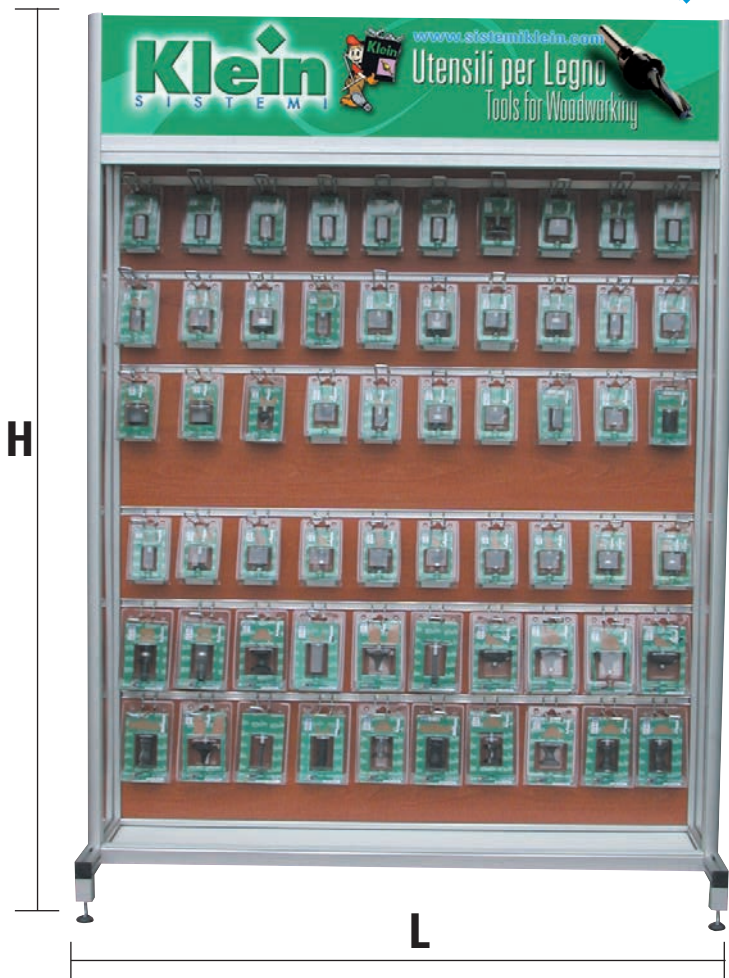

SOME MORE EXAMPLES OF DISPLAYS "STANDARD"



Router bits S=6/8 for portable routers
60 positions
 Router bits for ELU machines code **F101**
 "Forstner" bits code **R213**
 Hinge boring bits code **R111**



Router bits for ELU machines code **F101**
 "Forstner" bits code **R213**
 Hinge boring bits code **R111**
 Mortising bits code **S202**
 Diamond whetstones **DMT**



Router bits S=6/8 for portable routers
60 positions
 Circular saw blades for portable saws

PROFESSIONAL

3 modular panels

Big display consisting of three panels BASE, allows you to display a large variety of items.
With two or more displays you get the complete assortment to meet all the needs of professional woodworkers.
Dimensions (cm): 110 (L) x 200 (H) x 36 (P)

**Display
customizable**

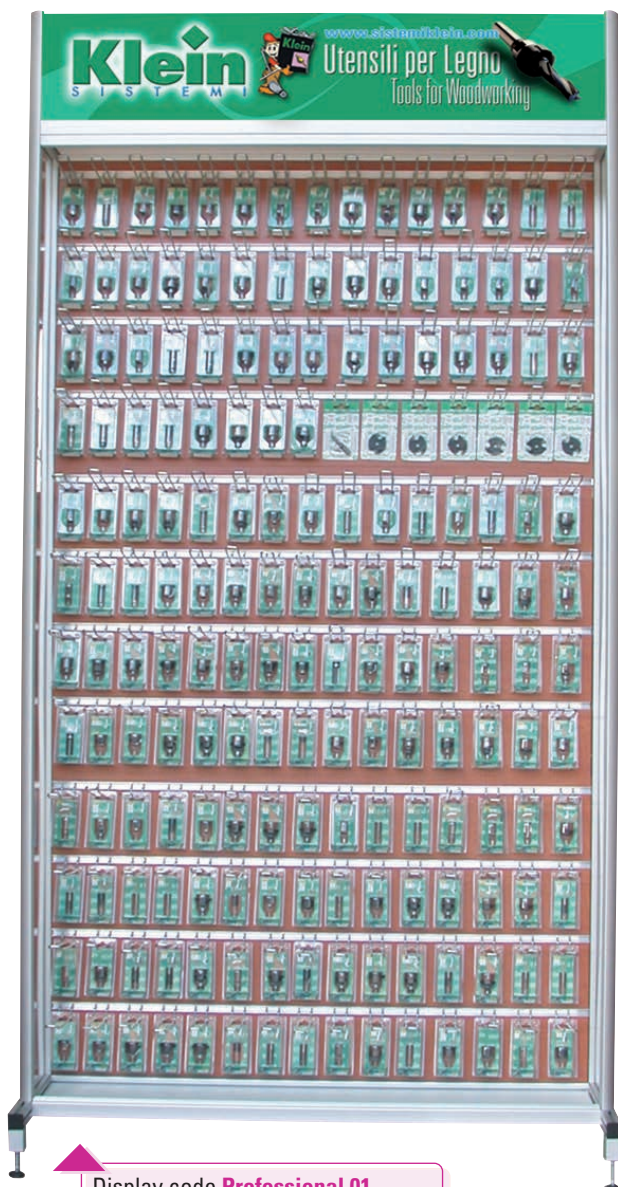

Display code **Professional 01**
includes:
Router bits for portable routers
S= 6/8 - 180 positions

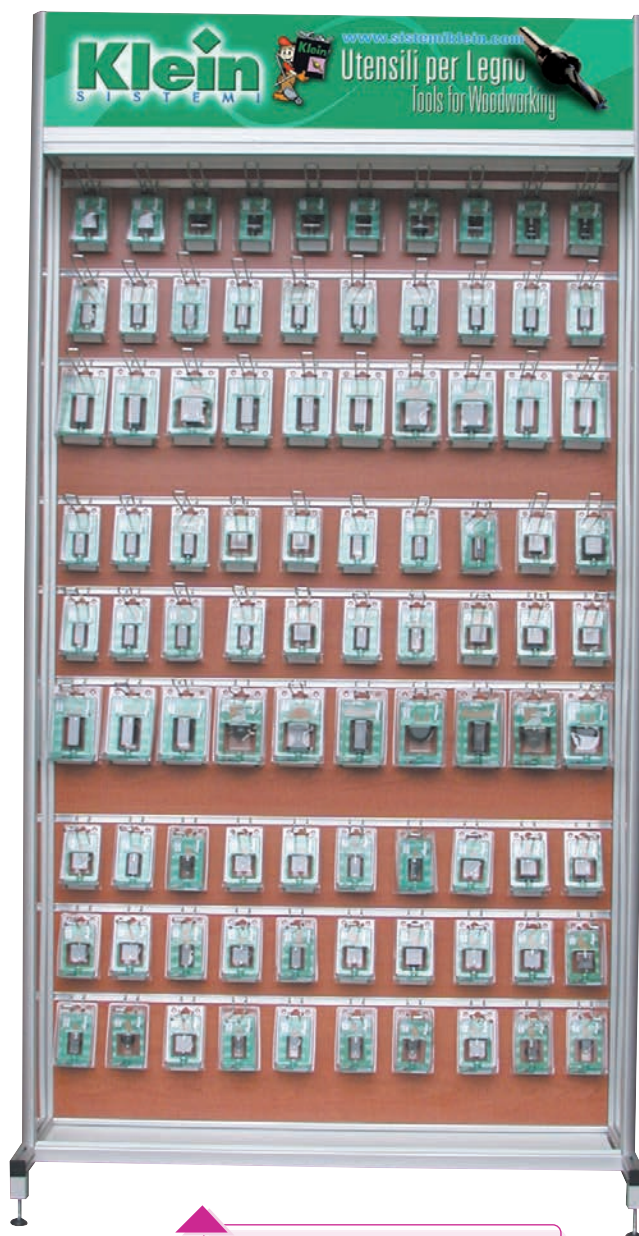

Display code **Professional 02**
includes:
Router bits for portable routers
S= 12 - 90 positions

SOME MORE EXAMPLES OF DISPLAYS "PROFESSIONAL"

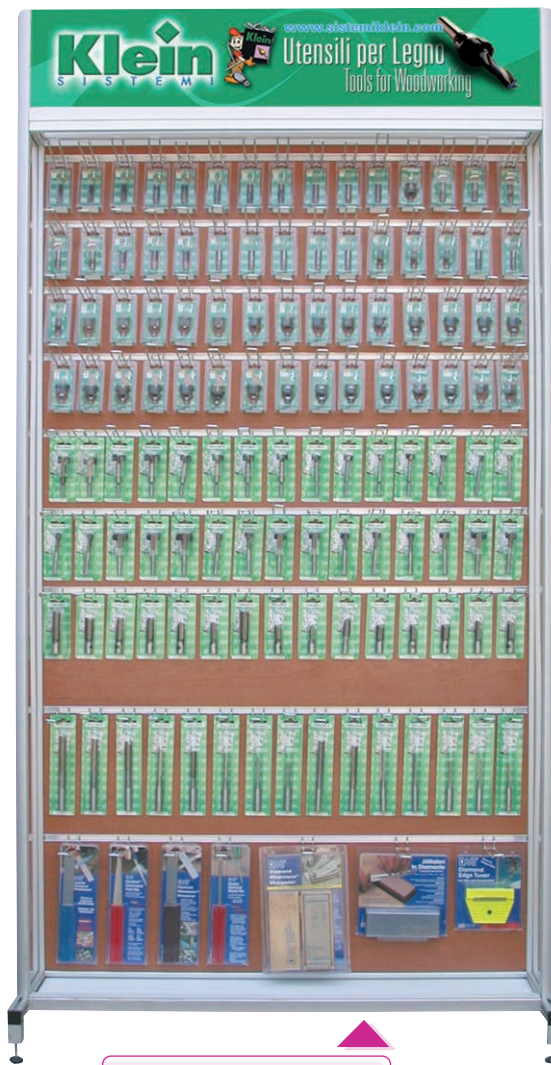

Router bits S=6/8 for portable routers
60 positions
 ELU machines code **F101**
 "Forstner" bits code **R213**
 Hinge boring bits code **R111**
 Mortising bits **S202**
 Diamond whetstones **DMT**



Router bits S=6/8 for portable routers
60 positions
 Router bits for ELU machines code **F101**
 "Forstner" bits code **R213**
 Hinge boring bits code **R111**
Circular saw blades for portable saws

Router bits S=6/8 for portable routers
60 positions
 ELU machines code **F101**
 "Forstner" bits code **R213**
 Hinge boring bits code **R111**
 Diamond whetstones **DMT**
 Accessories

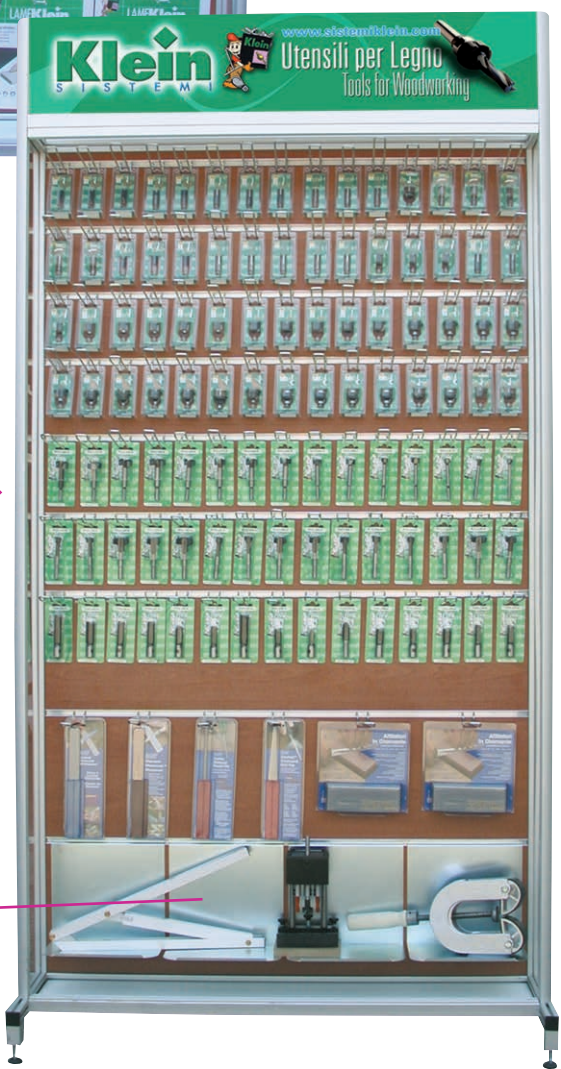

Aluminium shelf fitting on slatted panels with two rows for displaying products without hanging packaging

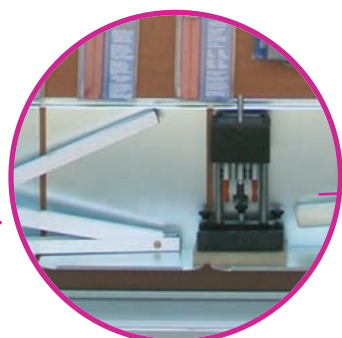

DRAWER UNIT

Modular drawer unit

Elegant, sturdy **Klein** drawer unit with an innovative, modern design and great modularity, where you can keep all your **Klein** tools in a clean, secure, well-organized place. Say good-bye to messiness and damaged tools. Now, with the new **Klein** drawer unit, you can put your storeroom in order in a convenient, functional way.

Dimensions (cm): 50 (L) x 110 (H) x 37 (P)



SMALL OUTSIDE BUT LARGE INSIDE
the **Klein** drawer unit takes up little space but can contain countless articles in its 10 drawers and 80 containers (8 containers per drawer).

- **STURDY**
since each drawer can hold around 8 kg.
- **LIGHT**
since it's made of a high-strength polypropylene co-polymer.
- **SECURE**
since each drawer has its own key.
- **PRACTICAL**
since it can be equipped with 4 casters for convenient movement or with slip-resistant feet.
- **CONVENIENT**
since it features a wooden top which acts as a practical surface for taking notes or keeping tools.
- **VERSATILE**
since the tubs in the drawers can be removed easily as desired.

Whether it's placed next to a CNC router, or close to a point-to-point boring machine, along the panel production line or in any carpentry shop, a new **Klein** drawer unit can be a real help in keeping the tools you use every day in perfect order and in good condition.



The new **Klein** drawer unit can hold a wide range of tools.
Ask our customer service how to receive it.



You can receive the new modular drawer by purchasing the following products

The drawer unit can be customized by replacing one or more drawers with others and/or replacing one or more single articles with others at your wish. The personalization must be agreed with our Customer Service

Modular drawer unit "Boring Machine"

Ideal to store dowel drills and boring bits beside your boring machine



1st Drawer
Drill holders

- Art. L001.100.R
- L001.100.L
- L002.100.R
- L002.100.L
- L030.100.R
- L030.100.L
- L031.100.R
- L032.100.R

2nd Drawer
Drills L=57,5

- Art. L103.040.R
- L103.040.L
- L103.050.R
- L103.050.L
- L103.060.R
- L103.060.L
- L103.070.R
- L103.070.L

3rd Drawer
Drills L=57,5

- Art. L103.080.R
- L103.080.L
- L103.100.R
- L103.100.L
- L103.120.R
- L103.120.L
- L103.140.R
- L103.140.L

4th Drawer
Drills L=70

- Art. L104.040.R
- L104.040.L
- L104.050.R
- L104.050.L
- L104.060.R
- L104.060.L
- L104.070.R
- L104.070.L

5th Drawer
Drills L=70

- Art. L104.080.R
- L104.080.L
- L104.100.R
- L104.100.L
- L104.120.R
- L104.120.L
- L104.140.R
- L104.140.L

6th Drawer
Through hole drills

- Art. L124.050.R
- L124.050.L
- L124.060.R
- L124.060.L
- L124.080.R
- L124.080.L
- L124.100.R
- L124.100.L

7th Drawer
Hinge boring bits

- Art. L140.150.R
- L140.150.L
- L140.180.R
- L140.180.L
- L140.200.R
- L140.200.L
- L140.250.R
- L140.250.L

8th Drawer
Hinge boring bits

- Art. L140.260.R
- L140.260.L
- L140.300.R
- L140.300.L
- L140.350.R
- L140.350.L
- L140.400.R
- L140.400.L

9th Drawer
High performance drills L=57,5

- Art. L114.050.R
- L114.050.L
- L114.060.R
- L114.060.L
- L114.080.R
- L114.080.L
- L114.100.R
- L114.100.L

10th Drawer
High performance drills L=70

- Art. L115.050.R
- L115.050.L
- L115.060.R
- L115.060.L
- L115.080.R
- L115.080.L
- L115.100.R
- L115.100.L

Modular drawer unit "CNC"

Ideal to store collet chucks, spring collets and spiral router bits beside your CNC machine



1st Drawer
Spring collets ER32

- Art. T119.060.N
- T119.080.N
- T119.100.N
- T119.120.N
- T119.140.N
- T119.160.N
- T119.180.N
- T119.200.N

2nd Drawer
Spring collets ER40

- Art. T123.080.N
- T123.100.N
- T123.120.N
- T123.140.N
- T123.160.N
- T123.180.N
- T123.200.N
- T123.250.N

3rd Drawer
Collet chucks and spring collets ER25

- Art. T118.700.R
- T118.800.R
- T118.976.R
- T118.980.R
- T125.060.N
- T125.080.N
- T125.100.N
- T125.120.N

4th Drawer
Spiral router bits Z=2

- Art. T142.040.R
- T142.050.R
- T142.061.R
- T142.080.R
- T142.081.R
- T142.100.R
- T142.101.R
- T142.121.R

5th Drawer
Spiral router bits Z=3

- Art. T143.081.R
- T143.100.R
- T143.101.R
- T143.121.R
- T143.161.R
- T143.180.R
- T143.200.R
- T143.201.R

6th Drawer
Spiral router bits Z=3 + chipbreaker

- Art. T144.081.R
- T144.100.R
- T144.101.R
- T144.121.R
- T144.161.R
- T144.180.R
- T144.200.R
- T144.201.R

7th Drawer
Spiral router bits Z=1

- Art. T141.030.R
- T141.040.R
- T141.050.R
- T141.061.R
- T141.081.R
- T141.100.R
- T151.061.R
- T151.081.R

8th Drawer
Spiral router bits Z=2 down-cut

- Art. T152.030.R
- T152.040.R
- T152.050.R
- T152.061.R
- T152.080.R
- T152.081.R
- T152.101.R
- T152.121.R

9th Drawer
Spiral router bits for locks

- Art. T153.100.R
- T153.120.R
- T153.160.R
- T154.081.R
- T154.120.R
- T154.160.R
- T157.140.R
- T157.162.R

10th Drawer
Straight cut router bits

- Art. D101.080.R
- D101.100.R
- D102.100.R
- D103.121.R
- D103.141.R
- D103.161.R
- D103.181.R
- D103.201.R

Modular drawer unit "Craftsman"

Ideal to store the most common tools in a workshop



1st Drawer
Router bits S=M12x1

- Art. F101.080.R
- F101.100.R
- F101.120.R
- F101.160.R
- F101.180.R
- F101.200.R
- F101.220.R
- F101.250.R

2nd Drawer
Router bits S=M12x1

- Art. F103.120.R
- F103.160.R
- F103.180.R
- F103.200.R
- F104.120.R
- F104.160.R
- F104.200.R
- F105.160.R

3rd Drawer
Hinge boring bits L=90

- Art. R111.150.R
- R111.180.R
- R111.200.R
- R111.250.R
- R111.260.R
- R111.300.R
- R111.350.R
- R111.400.R

4th Drawer
Forstner bits

- Art. R213.150.R
- R213.160.R
- R213.180.R
- R213.200.R
- R213.250.R
- R213.300.R
- R213.350.R
- R213.400.R

5th Drawer
Interchangeable hinge boring bits

- Art. R130.200.R
- R130.250.R
- R130.260.R
- R130.300.R
- R130.340.R
- R130.350.R
- R130.400.R
- Z021.408+410+412

6th Drawer
Interchangeable hinge boring bits

- Art. R130.450.R
- R130.480.R
- R130.500.R
- R130.550.R
- R130.600.R
- R130.650.R
- R130.700.R
- Z021.213+216+500

7th Drawer
Mortising bits R

- Art. S202.060.R
- S202.080.R
- S202.100.R
- S202.120.R
- S202.140.R
- S202.160.R
- S202.180.R
- S202.200.R

8th Drawer
Mortising bits L

- Art. S202.060.L
- S202.080.L
- S202.100.L
- S202.120.L
- S202.140.L
- S202.160.L
- S202.180.L
- S202.200.L

9th Drawer
Plug cutters

- Art. R220.080.R
- R220.100.R
- R220.120.R
- R220.150.R
- R220.200.R
- R220.250.R
- R220.300.R
- R220.350.R

10th Drawer
Reversible knives

- Art. Z055.000.N
- Z055.001.N
- Z055.003.N
- Z055.007.N
- Z055.008.N
- Z055.009.N
- Z055.010.N
- Z055.011.N

Instructions of use:

SAFE HANDLING:



All European and National safety regulations shall be adhered to include the safety requirements as set out in EN 847-1.

TRANSPORT :



Transport only in suitable packaging. Danger of damaging the cutting parts.



Caution: danger of injuring by sharp cutting edges! Wear safety gloves.

ASSEMBLING THE TOOL AND SETTING THE MACHINE:



Inspect the tool body and cutting parts for damage before mounting it in the machine. Damaged tools are to be checked by an expert. Do not use a deformed tool. All clamping area shall be free of pollution, grease, oil and water. Tighten clamping screws and nuts by using appropriate spanners and the recommended torque value. Danger of injuring by parts coming off!



While mounting, it shall be ensured, that the tool is clamped on the special clamping area. Cutting parts shall not come in contact with clamping elements and/or machine parts. When using stacked tooling ensure that the cutting parts do not foul each other. Check the cutting parts and basic bodies for damages.



The tools shall be mounted, locked and activated as per instructions of the machine manufacturer. Check the machine data and the direction of rotation.



Starting the machine during the tool change is not allowed (see handling instructions of the machine). Danger of injuring! Improper stopping of the tool, e.g. by lateral pressing, is not allowed.



After a tool breakage the collets also have to be exchanged. Tools with cracked bodies have to be taken out of service. Repairing such tools is not allowed. Carefully demount the tool.

MAINTENANCE:

Clean the collet and the tool holder regularly and before inserting the tool. Regular cleaning increases the operational safety. For reason of working safety, the cutting parts at the latest have to be serviced when:

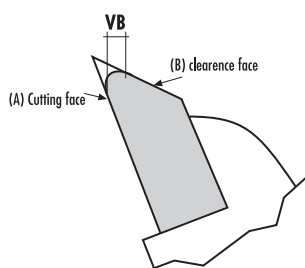

When the wear mark VB on the cutting parts has become more than 0.2mm – especially observe the main wear zones. (see section Servicing, modifying, sharpening)



Woodworking tools are to be protected against humidity in order to avoid corrosion. The cutting parts have to be regularly cleaned from resin and glue (built-up edges) this increasing thus the performance time and the operational safety.



Detergent can irritate skin and eyes and damage the tool. Protect hands and eyes while cleaning. Only use appropriate detergents and follow the instruction of the detergent producer.

Instructions of use:

SERVICING, MODIFYING AND SHARPENING:



Only experienced specialists are allowed to sharpen the tools as per instructions of the manufacturer.



Service and modification shall only be done by the manufacturer or by specialised workshops. Risk of tool-breakage. Only those spare parts are allowed to be used, which match the requirements of the original spare parts of the tool manufacturer. Tolerances, that guarantee a precise clamping, have to be kept.



Markings of the tool, which have been affected by modification / re-tipping, have to be updated. Name and logo of the modifying / re-tipping company have to be added. Specialists/specialized workshops shall be experienced in the relevant:

- up-to-date engineering referring construction and design;
- national regulation;
- appropriate safety regulations and standard.

They shall have:



- the standard equipment and
- the capability of doing these operations.

After any sharpening, servicing or modification process, it shall be ensured, that the tool meets the requirements of the European Standard EN 847-1, EN 847-2 and EN 847-3.



Re-tipping of cutting plates is only allowed by specialists who are experienced in brazing process referring tensions in the body and the cutting material. The design of composite tools (e.g. tools with brazed cutting plates) is not allowed to be changed.

Symbols

| | |
|--|--|
| | Consult service manual |
| | Insert safety lock before getting in hazardous area |
| | General modatory action |
| | Wear safety gloves |
| | Danger (general prohibition) |
| | Do not operate with damaged blade |
| | General danger |

Safety regulations

The most important rules in the production of tools are regulated by the European standards En 847, sections 1 to 3 "Tools for Woodworking - Safety requirements". Here are defined the minimum requirements to which, according to the current state of technology, must meet a tool for working wood, in order to be considered safe.

European standards:

| | |
|-----------------|---|
| EN 847-1 | EN 847-1 Milling tools, circular saw blades |
| EN 847-2 | EN 847-2 Requirements for the shank of shank-mounted milling tools |
| EN 847-3 | EN 847-3 Requirements for clamping devices |

Wood

Wood is a natural resource that is both always renewable and crucial to mankind. Other resources come to an end, but wood will always be there, as long as we look after our forests and only cut down plants once they are fully grown, so that can give new plants the space they need to grow. Wood is healthy, strong, durable and diverse, and is available in an infinite range of colours, grains, shades and knots. A wood product will never be an exact copy of another; it will always be inimitable and exceptional.



The most popular woods for woodworking



Cherry



Ebony



Beech



Mahogany



Walnut



Rosewood

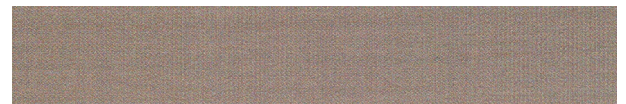

Pera Tree



Pine



Briarwood



Oak



Teak



Wengè

HARDNESS:

Wood is classified according to its hardness into one of three categories: hardwood, semi-hardwood or softwood. This order respects its values as well. Exotic woods are among the hardest ones, which is why they are held in greater esteem. Nonetheless, others include our native hornbeam, boxwood, acacia, olive tree, pear tree and ash - just to name some of the most popular hardwoods used in modern woodworking. In terms of semi-hardwoods, some of the most commonly used are cherry, beech, chestnut, walnut, elm, plane tree and alder, while the following are softwoods: fir, birch, poplar and linden. Balsa and samba (exotic) are so soft that they can be scratched using your nails.

LIGHT AND HEAVY:

some woods sink like stones as soon as they are placed in water, others instead are as light as polystyrene. Some woods are beautiful, others are not particularly attractive, but all are useful. Recognising different types of woods without hesitating, weighing up their potential and being able to see how they can be used to the best of their advantage are essential skills required of all those who want to work with wood in a proficient manner and achieve good results. Wood is classified according to its origin, and can be either European or exotic. The first, obviously, comes from trees that grow on the European continent, such as birch, elm, linden, maple, walnut etc., and include a number of resinous woods, such as fir, pine, Swiss pine, cypress, yew and larch. The second are exotic tree species from continents other than Europe (North America, Africa, etc.). Without wanting to disparage local woods, we must say that the latter are held in higher regard as a whole.

Recyclable packaging

The evident problem of waste management has increasingly become of worldwide importance. Always watchful of the problems that surround us, **SISTEMI** already several years ago decided to use only recyclable materials for its packaging. Waste recycling means all the strategies employed to recover waste materials and reuse them rather than dispose of them.

Recyclable materials are marked with the following symbol



Many types of plastic can easily be recycled

All our packaging in which plastics are used is recyclable and marked with the Unicode (recycling symbol) which contemplates numerical identification of recyclable plastics.



HDPE
High density polyethylene



PVC
Polyvinyl chloride



PP
Polypropylene or Moplen

All our packaging in which paper and cardboard are used are marked with the **RESY** recycling symbol, meaning that the raw material (paper and cardboard) is recycled and 100% recyclable.



All our packaging is printed and glued with vegetable oil-based inks and glues with an ecological intent: reduction of volatile organic compounds.

FOTOVOLTAIC SOLAR PANELS

We should stake on alternative sources of energy in order to grant a better future to our children. Because of this, **SISTEMI** opted for a fotovoltaic panel system.

Sensitive as usual to the environment themes, **SISTEMI** installed solar panels in the year 2011 for the production of electric power. The power system ensures approx. 70% of the electric requirements of the company.







Item and Page Index

| Item | Page | Item | Page | Item | Page |
|----------------------------------|------------|--------------------|--------------|-------------------------|-----------------------|
| A101/2/3 - B101/2/3 - C101/2/3 | 1.07, 1.08 | A165 - B165 - C165 | 1.20 | C190 | 1.23 |
| A104 - B104 - C104 | 1.08 | A166 - B166 - C166 | 1.20 | C192 | 1.24 |
| A105 - B105 - C105 | 1.08 | A167 - B167 | 1.20 | C240 | 1.24 |
| A106 - C106 | 1.08 | A168 - B168 | 1.21 | CA | 12.14 |
| A107 - B107 - C107 | 1.08 | A169 - B169 | 1.21 | CALIBRATION CERTIFICATE | 15.21 |
| A108 - B108 - C108 | 1.09 | A170 - C170 | 1.21 | CB - CBS | 12.14 |
| A109 - B109 - C109 | 1.09 | A180 - B180 | 1.21 | CC - CCS | 12.14 |
| A110 - B110 - C110 | 1.09 | A181 - C181 | 1.22 | CD - CDS | 12.15 |
| A111 - B111 - C111 | 1.09, 1.10 | A182 - C182 | 1.22 | CE - CES | 12.15 |
| A112 - B112 - C112 | 1.10 | A185 | 1.22 | CF | 12.16 |
| A113 - B113 - C113 | 1.10 | A186 - B186 | 1.22 | CG | 12.16 |
| A114 - B114 - C114 | 1.10 | A191 | 1.22 | CH | 12.16 |
| A115 - B115 - C115 | 1.10 | A195 - C195 | 1.22 | D101 | 2.05 |
| A116 - B116 - C116 | 1.10 | A196 - B196 - C196 | 1.22 | D102 | 2.05 |
| A117 - B117 - C117 - E117 - G117 | 1.11 | A199 | 1.23, 6.04 | D103 | 2.05 |
| A118 | 1.11 | A4 | 14.04 | D4 | 14.07 |
| A119 - B119 - C119 | 1.12 | AA | 12.12 | D6 | 14.07 |
| A120 - B120 - C120 | 1.12 | AB | 12.13 | DA | 12.16 |
| A121 - B121 - C121 | 1.13 | AF | 12.38 | DC | 12.17 |
| A122 - B122 - C122 | 1.13 | AG | 1.23 | DIGIT950 | 15.22, 15.26 |
| A123 - B123 - C123 | 1.13 | AH | 12.13, 13.03 | DIGIT955 | 15.22 |
| A124 - B124 - C124 | 1.14 | AL | 12.13 | DIGIT980/985/986/987 | 15.25 |
| A125 - B125 - C125 | 1.14 | ANGOLFAST | 15.14 | DIGIT990 | 15.23, 15.26 |
| A126 - B126 - C126 | 1.14 | ARKADE | 16.03 | DIGIT991 | 15.23 |
| A127 - B127 - C127 | 1.14 | AS1500201 | 15.29 | DIGIT992 | 15.24 |
| A128 - B128 - C128 | 1.14 | AS1500224 | 15.29 | DISPLAY UNITS | 2.31, 4.07, IX |
| A129 - B129 - C129 | 1.15 | AST.CAL | 15.21 | DRAWER UNIT | 5.24, 6.15, 7.63, XVI |
| A130 - B130 - C130 | 1.15 | B.ORI | 16.17 | E101 - G101 | 2.05 |
| A131 - B131 - C131 | 1.15 | B.PNE | 16.17 | E102 - G102 | 2.06 |
| A132 - B132 - C132 | 1.15 | B.PUNTALE | 16.17 | E103 - G103 | 2.06 |
| A133 - B133 - C133 | 1.15 | B.SPI | 16.17 | E104 - G104 | 2.06 |
| A134 - B134 - C134 | 1.15 | B.VER | 16.17 | E105 - G105 | 2.06 |
| A135 - B135 - C135 | 1.16 | BCE | 15.28, 15.29 | E106 - G106 | 2.06 |
| A136 - B136 - C136 | 1.16 | C.CORS.PER | 15.16 | E107 - G107 | 2.06 |
| A137 - B137 - C137 | 1.16 | C.CORS.V90° | 15.16 | E108 - G108 | 2.06 |
| A138 - B138 | 1.16 | C.DIGIT.Z3 | 15.03 | E109 - G109 | 2.07 |
| A139 - B139 | 1.16 | C.DIS.040 | 15.20, 15.24 | E110 - G110 | 2.07 |
| A140 | 1.16 | C.INT | 15.16 | E111 - G111 | 2.07 |
| A141 - B141 | 1.17 | C.INV | 15.16 | E112 - G112 | 2.07 |
| A142 - B142 - C142 | 1.17 | C.L45 | 15.20 | E113 - G113 | 2.07 |
| A144 - B144 | 1.17 | C.LETTORE | 15.21 | E114 - G114 | 2.07 |
| A145 - B145 - C145 | 1.17 | C.LIE | 15.17 | E115 - G115 | 2.08 |
| A146 - C146 | 1.17 | C.LIE.L.PA | 15.25 | E116 - G116 | 2.08 |
| A147 - B147 - C147 | 1.18 | C.LIE.PA | 15.17 | E118 - G118 | 2.08 |
| A150 - C150 | 1.18 | C.LIN | 15.15 | E119 - G119 | 2.08 |
| A151 - C151 | 1.18 | C.LIN.D | 15.20 | E120 - G120 | 2.08 |
| A152 - C152 | 1.18 | C.LIN.L | 15.19 | E121 - G121 | 2.08 |
| A153 - B153 - C153 | 1.18 | C.LIN.L.PA | 15.19 | E122 - G122 | 2.09 |
| A154 - C154 | 1.18 | C.LIN.PA | 15.15 | E123 - G123 | 2.09 |
| A155 | 1.18 | C.LIN.PB | 15.18 | E124 - G124 | 2.09 |
| A156 | 1.19 | C.LIN.PI | 15.18 | E125 - G125 | 2.09 |
| A157 - B157 | 1.19 | C.PER.0415 | 15.16 | E126 | 2.09 |
| A158 - B158 | 1.19 | C.PER.1415 | 15.18, 15.23 | E127 - G127 | 2.09 |
| A159 - B159 | 1.19 | C.PER.B12 | 15.18 | E128 - G128 | 2.09 |
| A160 - B160 | 1.19 | C.PERS.V90° | 15.16 | E129 - G129 | 2.09 |
| A161 - B161 | 1.19 | C.PERNO.03-35 | 15.16 | E130 - G130 | 2.10 |
| A162 - B162 | 1.19 | C112 | 1.10 | E131 - G131 | 2.10 |
| A163 - B163 | 1.20 | C118 | 1.11, 1.12 | E132 - G132 | 2.10 |
| A164 - B164 | 1.20 | C173 | 1.21 - 8.07 | E133 | 2.10 |

Item and Page Index

| Item | Page | Item | Page | Item | Page |
|--------------------|------------|--------------------|-------------|---|--------------|
| E134 - G134 | 2.10 | E300 - G300 | 3.05 | FCT  | 12.18 |
| E135 - G135 | 2.11 | E301 - G301 | 3.05 | FE | 12.19 |
| E136 - G136 | 2.11 | E302 - G302 | 3.05 | FF | 14.05 |
| E137 - G137 | 2.11 | E305 | 3.05 | FG | 12.19 |
| E138 - G138 | 2.11 | E306 | 3.05 | FH | 12.20 |
| E139 - G139 | 2.11 | E307 | 3.05 | FI | 12.27 |
| E140 - G140 | 2.11 | E310 - G310 | 3.06 | FK | 12.20 |
| E141 - G141 | 2.12 | E312 - G312 | 3.06 | FL | 12.28 |
| E142 - G142 | 2.12 | E315 | 3.06 | FM | 12.30 |
| E143 - G143 | 2.12 | E316 - G316 | 3.06 | FP | 12.30 |
| E144 - G144 | 2.12 | E317 - G317 | 3.06 | FSK | 14.05 |
| E145 - G145 | 2.12 | E321 | 3.07 | FT | 12.38 |
| E146 - G146 | 2.12 | E325 - G325 | 3.07 | FW | 14.05 |
| E147 - G147 | 2.13 | E326 - G326 | 3.07 | GA | 12.31 |
| E148 - G148 | 2.13 | E330 - G330 | 3.07 | GR2.W1.FL | 16.20 |
| E149 - G149 | 2.13 | E333 - G333 | 3.07 | GR2.W2.FL | 16.20 |
| E150 - G150 | 2.13, 2.14 | E334 - G334 | 3.08 | GR2.WD.FL | 16.20 |
| E151 - G151 | 2.14 | E335 - G335 | 3.08 | GR2.WS.FL | 16.19 |
| E152 - G152 | 2.14 | E336 - G336 | 3.08 | GR2.WV.FL | 16.19 |
| E153 | 2.14 | E338 | 3.08 | GR2.WZ.FL | 16.19 |
| E154 - G154 | 2.15 | E340 - G340 | 3.08 | GR3.WD.UL | 16.21 |
| E156 - G156 | 2.15 | E342 - G342 | 3.09 | GR3.WS.UL | 16.21 |
| E157 - G157 | 2.15 | E350 - G350 | 3.09 | GR3.WX.UL | 16.21 |
| E158 - G158 | 2.15 | E360 | 3.09 | GR3.WZ.UL | 16.21 |
| E159 | 2.15 | E361 | 3.09 | HA101 - HB101 - HC101 | 4.03 |
| E160 | 2.15 | E362 | 3.09 | HA108 - HB108 - HC108 | 4.03 |
| E161 - G161 | 2.16 | E363 | 3.09 | HA109 - HB109 - HC109 | 4.03 |
| E162 - G162 | 2.16 | E364 | 3.10 | HA110 - HB110 - HC110 | 4.03 |
| E163 - G163 | 2.16 | E365 | 3.10 | HA111 - HB111 - HC111 | 4.03 |
| E165 - G165 | 2.16 | E366 | 3.10 | HA115 - HB115 - HC115 | 4.03 |
| E166 - G166 | 2.16 | E367 | 3.10 | HA119 - HB119 - HC119 | 4.03 |
| E167 - G167 | 2.17 | E368 | 3.10 | HA121 - HB121 - HC121 | 4.03 |
| E168 - G168 | 2.17 | E370 | 3.11 | HA122 - HB122 - HC122 | 4.04 |
| E169 - G169 | 2.17 | E371 | 3.11 | HA123 - HB123 - HC123 | 4.04 |
| E170 - G170 | 2.17 | E373 | 3.11 | HA124 - HB124 - HC124 | 4.04 |
| E171 - G171 | 2.18 | E374 | 3.11 | HA125 - HB125 - HC125 | 4.04 |
| E172 - G172 | 2.18 | E375 | 3.11 | HA127 - HB127 - HC127 | 4.04 |
| E173 - G173 | 2.18 | E376 | 3.12 | HA128 - HB128 - HC128 | 4.04 |
| E174 - G174 | 2.18 | E377 | 3.12 | HB190 | 4.05 |
| E175 - G175 | 2.18 | E378 | 3.12 | HB191 | 4.05 |
| E176 - G176 | 2.18 | E380 - G380 | 3.12 | HB192 | 4.05 |
| E177 - G177 | 2.19 | E381 | 3.12 | HB193 | 4.05 |
| E178 - G178 | 2.19 | E382 - G382 | 3.13 | HBS | 12.28 |
| E179 - G179 | 2.19 | E383 - G383 | 3.13 | HCS | 12.29 |
| E180 - G180 | 2.20 | E384 | 3.13 | HX002 | 4.06 |
| E181 - G181 | 2.20 | ELLIX/ELLISISTEM | 16.03 | HX005 | 4.06 |
| E182 - G182 | 2.21 | F101 | 3.14 | K.M. | 15.27 |
| E186 - G186 - C186 | 2.21 | F103 - F104 - F105 | 3.14 | KA | 12.33 |
| E187 - G187 - C187 | 2.22 | F108 | 3.15 | KLEINTOPUP.400 | 14.03 |
| E188 - G188 - C188 | 2.22 | F110 | 3.15 | KLEINDRYUP.400 | 14.03 |
| E189 - G189 - C189 | 2.23 | F111 | 3.15 | KLEINPROTECT.400 | 14.03 |
| E191 - G191 - C191 | 2.23 | F112 | 3.16 | KLEINPROTECT.5000 | 14.03 |
| E193 - G193 - C193 | 2.24 | F114 | 3.16 | KLEINCLEANUP.1000 | 14.03 |
| E194 - G194 - C194 | 2.24 | F152 - F153 | 3.14 | KLEINCLEANUP.10000 | 14.03 |
| E195 - G195 - C195 | 2.25 | F160 - F161 | 3.15 | KLEINWASHER | 14.03, 16.18 |
| E196 - G196 - C196 | 2.25 | F70 | 14.05 | KLEINCLEANER | 14.03, 16.18 |
| E197 - G197 - C197 | 2.26 | FAS | 12.17 | K.START.2 | 16.18 |
| E198 - G198 - C198 | 2.26 | FB | 8.13, 12.17 | K.FG500 | 16.18 |
| E199 - G199 - C199 | 2.27 | FCS | 8.13, 12.18 | L001 | 5.04 |



Item and Page Index

| Item | Page | Item | Page | Item | Page |
|---|-------------|--------------------------------|----------------------------|--|--------------|
| L002 | 5.04 | M121 - M122 - M123 | 5.22 | S121 - S221 | 6.13 |
| L003 | 5.04 | M131 - M132 | 5.22 | S122 - S222 | 6.14 |
| L004 | 5.04 | M141 - M142 | 5.22 | S123 - S223 | 6.14 |
| L005 | 5.04 | M151 | 5.22 | S180 | 6.15 |
| L006 | 5.04 | MES | 12.34 | S181 | 6.15 |
| L030 | 5.05 | MGS | 8.13, 12.34 | S182 | 6.15 |
| L031 | 5.05 | MLS - MMS | 12.35 | S201 - S202 | 6.12 |
| L032 | 5.05 | MP | 12.35 | S210 - S211 - S212 - S213 | 6.13 |
| L033 | 5.05 | N101 - N102 | 5.23 | S214 | 6.13 |
| L034 | 5.06 | N121 - N131 | 5.22 | S250 | 6.14 |
| L035 | 5.06 | N135 - N136 | 5.23 | S260 | 6.14 |
| L036 | 5.06 | N150 | 5.23 | S270 | 6.14 |
| L040 | 5.06 | PA - PB | 12.35 | SA | 13.04, 13.05 |
| L050 | 5.06 | PDW6 | 14.06 | SA0 | 13.10÷13.15 |
| L051 | 5.06 | PRE SET PERFORMANCE | 15.04, 15.05 | SA1 | 13.10÷13.15 |
| L052 | 5.07 | PRE SET B | 15.12, 15.13 | SA2 | 13.16÷13.20 |
| L053 | 5.07 | PRE SET BL | 15.04, 15.06, 15.08, 15.10 | SA3 | 13.16÷13.20 |
| L054 | 5.07 | PRE SET LEADER PLUS | 15.06, 15.07 | SAL | 13.05 |
| L060 | 5.06 | PRE SET P322 | 15.03 | SPP020021 | 16.16 |
| L101 - L102 | 5.07 | PRE SET P368LR - P368LR/HSK63F | 15.12, 15.13 | SPP020022 | 16.16 |
| L103 - L104 | 5.08 | PRE SET PRIME | 15.10, 15.11 | SPP040077 | 15.29 |
| L105 - L106 - L107 - L108 | 5.08 | PRE SET P368XL | 15.13 | SPP040079 | 15.29 |
| L109 | 5.09 | PRE SET UNIKO | 15.08, 15.09 | SPP040107 | 15.29 |
| L110 | 5.09 | R100 | 6.03 | SPP040080 | 15.29 |
| L112 - L113 | 5.10 | R101 | 6.03 | SPP060028 | 16.15 |
| L114 - L115 | 5.11 | R102 | 6.03 | SPP060029 | 16.15 |
| L116 - L117 | 5.12 | R104 - R204 | 6.06 | SPP060036 | 16.05 |
| L116KD - L117KD  | 5.12 | R108 - R209 | 6.06 | SPP060037 | 16.05 |
| L118 | 5.12 | R110 | 6.07 | SPP060039 | 16.15 |
| L119 | 5.12 | R111 | 6.07 | SPP060047 | 16.15 |
| L120 | 5.13 | R112 | 6.08 | SPP060052 | 16.16 |
| L121 - L122 | 5.07 | R125 | 6.03 | SPP060053 | 16.15 |
| L123 - L124 - L125 | 5.14 | R130 | 6.08 | SPP060065 | 16.15 |
| L126 - L127 | 5.14 | R150 - R250 | 6.09 | SPP060075 | 16.16 |
| L129 | 5.15 | R151 - R251 | 6.12 | SX001 - SXL001 | 13.06 |
| L129KD  | 5.15 | R152 | 6.12 | SX002 - SXL002 | 13.07 |
| L130 | 5.16 | R155 | 6.10 | SX003 - SXL003 | 13.08 |
| L131 | 5.16 | R156 | 6.10 | SX004 - SXL004 | 13.09 |
| L132 - L133 | 5.17 | R158 | 6.11 | T110 | 7.09 |
| L134 - L135 | 5.17 | R159 | 6.11 | T112 | 7.09 |
| L134KD - L135KD  | 5.17 | R160 - R260 | 6.12 | T116 | 7.09 |
| L136 - L137 | 5.16 | R200 | 6.03 | T117 | 7.09 |
| L138 - L139 | 5.16 | R201 | 6.04 | T118 COLLET CHUCKS | 7.10÷7.17 |
| L140 - L141 | 5.18 | R202 | 6.05 | T118 COLLET CHUCKS INOX | 7.23 |
| L142 | 5.18 | R203 | 6.06 | TK118 OVERLINE  | 7.18, 7.19 |
| L143 - L144 | 5.19 | R205 | 6.04 | TJ118 COLLET CHUCKS | 7.20 |
| L150 - L151 | 5.18 | R206 | 6.04 | T118 RETAINING PAWLS | 7.39 |
| L155 - L156 | 5.19 | R207 | 6.05 | T119 | 7.25, 7.26 |
| L160 | 5.20 | R208 | 6.06 | T120 SHRINK FIT CHUCKS  | 7.21 |
| L170 | 5.20 | R210 - R215 - R216 | 6.11 | T120 SHRINK FIT CHUCKS EXTENSIONS | 7.22 |
| L171 | 5.20 | R213 | 6.09 | T121 STRAIGHT SHANK TOOL EXTENSIONS | 7.22 |
| L174 | 5.20 | R214 | 6.09 | T123 | 7.25, 7.26 |
| LA | 8.14, 12.32 | R220 | 6.09 | T124 | 7.27 |
| LB | 8.14, 12.32 | R221 | 6.11 | T125 | 7.27 |
| LE | 8.15, 12.33 | R225 | 6.05 | T126 | 7.27 |
| LIFTER100 | 16.16 | R226 | 6.05 | T127 | 7.28 |
| LZ | 12.34 | RA | 13.03 | T128 | 7.32 ÷ 7.36 |
| M101 - M102 - M103 | 5.21 | S110 - S111 | 6.13 | T129 | 7.28 |
| M111 - M112 - M113 | 5.21 | S120 - S220 | 6.13 | T130 - T131 SPECIAL ROUTER BITS | 7.43 |

Item and Page Index

| Item | Page | Item | Page | Item | Page |
|-------------------------|--------------|----------------------------------|---|----------------------------|-----------------------|
| T130 - T131 - T132 | 7.37 | TNL | 13.29 | U250 | 8.11 |
| T132 | 7.37 | TRIMATIC 22 | 16.10 | U260 | 8.11 |
| T133 | 7.29 | TRIMATIC 25 | 16.10 | U270 | 8.11 |
| T134 | 7.28 | TRIMATIC 28 | 16.10 | U290 - U291 | 8.11 |
| T135 | 7.28 | TRIMATIC 22,4 | 16.11 | U302KD | Klein DIA 8.08 |
| T136 | 7.28 | TRIMATIC 32 | 16.08 | W101 - W102 | 9.05 |
| T137 | 7.40 | TRIMATIC 38/7,5 | 16.06 | W103 - W104 | 9.05 |
| T138 | 7.29 | TRIMATIC 42/11 | 16.06 | W105 - W106 | 9.05 |
| T139 | 7.41 | TRIMATIC 43/0 | 16.09 | W107 - W108 | 9.05 |
| T139 TORNADO ▼Tornado | 7.42 | TRIMATIC 45/9,5 | 16.06 | W109 - W110 | 9.05 |
| T141 | 7.46 | TRIMATIC 48/6 | 16.06 | W111 - W112 | 9.06 |
| T142 | 7.47 | TRIMATIC 48/9 | 16.06 | W113 - W114 | 9.06 |
| T142KD Klein DIA | 7.59 | TRIMATIC 52/5,5 | 16.06 | W115 - W116 | 9.06 |
| T143 | 7.48 | TRIMATIC 52/7,5 | 16.06 | W120 - W121 - W122 | 9.07 |
| T143KD Klein DIA | 7.59 | TRIMATIC 52/9 | 16.06 | W123 - W124 - W125 | 9.07 |
| T144 | 7.49 | TRIMATIC SUPER 22,4 | 16.14 | W126 - W127 | 9.08 |
| T144KD Klein DIA | 7.59 | TRIMATIC SUPER 32/90° | 16.14 | W138 | 3.13, 9.08 |
| T146 - T147 | 7.50 | TRIMATIC SUPER 38/7,5 | 16.12 | W140 | 9.08 |
| T151 | 7.50 | TRIMATIC SUPER 42/11 | 16.12 | W155 | 9.08 |
| T152 | 7.50 - 7.51 | TRIMATIC SUPER 43/0 | 16.13 | W160 | 9.09, 9.10 |
| T153 | 7.51 | TRIMATIC SUPER 45/9,5 | 16.12 | W161 | 9.09, 9.10 |
| T154 | 7.51 - 7.52 | TRIMATIC SUPER 48/6 | 16.12 | W162 | 9.11 |
| T155 | 7.52 | TRIMATIC SUPER 48/9 | 16.12 | W165 | 9.09 |
| T156 | 7.53 | TRIMATIC SUPER 52/5,5 | 16.12 | W168 | 9.13 |
| T156M | 7.53 | TRIMATIC SUPER 52/7,5 | 16.12 | W170 | 9.13 |
| T157 | 7.52 | TRIMATIC SUPER 52/9 | 16.12 | W171 | 9.13 |
| T158 | 7.54 | TS | 13.34 | W172 - W173 | 9.14 |
| T159 | 7.54 | TSL | 13.34 | W174 | 9.14 |
| T160 | 7.55 | TTL | 13.35, 13.36 | W176 - W177 | 9.14 |
| T161 | 7.55 | TVL | 13.38 | W178 - W179 | 9.15 |
| T162 | 7.55 | TWL | 13.37 | W181 | 9.15 |
| T163 | 7.55 | TX | 13.25, 13.28÷13.33, 13.36, 13.38, 13.44 | W182 - W183 | 9.15 |
| T164 | 7.55 | TYL | 13.39÷13.41 | W190 - WE190 - WG190 | 9.15 |
| T168 | 7.55 | TZA | 13.43 | W190RU - WE190RU - WG190RU | 8.11, 9.15 |
| T170 | 7.56 | TZL | 13.42 | W200 - W201 | 9.22 |
| T171 | 7.56 | U101 | 8.04 | W202 - W203 - W204 - W205 | 9.22 |
| T173 | 7.56 | U101KD Klein DIA | 8.06 | W206 - W207 - W208 | 9.23 |
| T175 | 7.56 | U102 | 8.04 | W209 - W210 | 9.23 |
| T177 - T178 | 7.52 | U102KD Klein DIA | 8.06 | W211 - W212 - W213 | 9.23 |
| T213 - T214 | 7.57 | U111 - U112 | 8.04 | W214 - W215 - W216 | 9.24 |
| T215 - T216 | 7.57 | U111KD - U112KD Klein DIA | 8.06 | W250 - W251 | 9.24 |
| T244 | 7.57 | U115 | 8.04 | W252 - W253 | 9.24 |
| T344KD Klein DIA | 7.60 | U115KD Klein DIA | 8.08 | W254 | 9.24 |
| T354KD Klein DIA | 7.60 | U120 | 8.04 | W260 | 9.25 |
| T356 | 7.54 | U120KD Klein DIA | 8.06 | W261 - W262 | 9.25 |
| T356M | 7.54 | U130KD Klein DIA | 8.08 | W263 - W264 | 9.25 |
| T357KD Klein DIA | 7.59 | U140 | 8.07 | W4 | 14.04 |
| T.SFERA | 15.12, 15.13 | U150 | 8.07 | W6 - W8 - WT | 14.06 |
| TA | 13.21 | U155 - U156 | 8.07 | WAVF | 14.07 |
| TAH | 13.22 | U180 | 8.08 | WC101 | 1.25, 9.16 |
| TB | 13.22 | U181 | 8.08 | WC109 | 1.25, 9.16 |
| TC | 13.23 | U190 | 8.07 | WC111 | 1.25, 9.16 |
| TEL | 13.23 | U201 - U211 - U221 | 8.09 | WC120 | 1.25, 9.16 |
| TF | 13.24 | U201KD Klein DIA | 8.10 | WC121 | 1.25, 9.16 |
| THL | 13.25 | U202 | 8.09 | WC122 | 1.26, 9.17 |
| TI | 13.26 | U202KD Klein DIA | 8.10 | WC123 | 1.26, 9.17 |
| TIL | 13.26 | U230 | 8.10 | WC125 | 1.26, 9.17 |
| TLL | 13.27 | U240 | 8.10 | WC129 | 1.26, 9.17 |
| TML | 13.28 | U241 | 8.10 | WE100 | 9.18 |

Item and Page Index

| Item | Page | Item | Page |
|-------------------------------|------------------|-----------------------|--|
| WE101 | 9.18 | XFC | 9.30, 12.36 |
| WE112 | 9.18 | XFI | 9.30, 12.36 |
| WE150 | 9.19, 9.20 | XFL | 9.30, 12.36 |
| WE178 | 9.20, 9.21 | XGE | 9.29, 12.37 |
| WM | 14.04 | XHC | 9.31, 12.37 |
| WM8FC-WB | 14.07 | XW160 | 9.12 |
| WS7 | 14.04 | XW162 | 9.11 |
| X001 | 1.27 | XWC | 1.35, 9.17 |
| X002 | 1.27 | XZ055 | 11.10 |
| X003 | 1.28 | Y100 | 11.12 |
| X005 | 1.30 | Y200 | 11.12 |
| X006 | 1.31 | YC 320 | 8.12 |
| X007 | 1.32 | YD 320 | 8.12 |
| X008 | 1.33 | YD300/350/400/500/600 | 7.38, 10.16 |
| X011 | 1.28 | YF 060÷YF120 | 8.12 |
| X012 | 1.29 | YG | 8.13 |
| X013 | 1.34 | Z001 | 1.24, 10.03 |
| X015 | 8.09 | Z002 | 10.03 |
| X021 | 2.28 | Z003 | 10.03 |
| X022 | 2.28 | Z010 | 5.13, 10.03 |
| X023 | 2.29 | Z011 | 5.13, 10.04 |
| X024 | 2.29 | Z021 | 10.04, 10.05 |
| X025 | 2.30 | Z050 | 10.05, 13.43 |
| X026 | 2.30 | Z051 | 7.17, 10.06, 10.07 |
| X100 | 6.11 | Z052 | 7.31, 10.07 |
| X116 | 7.09 | Z052 TOR. WRENCHES | 7.31, 7.32, 7.42, 10.08, 10.09 |
| X118 | 7.30 | Z053 | 10.10 |
| X118 TOOL KIT FOR CNC ROUTERS | 7.61, 7.62 | Z054 | 10.10 |
| X119 | 7.25, 7.26, 7.29 | Z055 | 10.10, 10.11, 11.04÷11.06 |
| X123 | 7.25, 7.26, 7.29 | Z055KD |  11.08, 11.09 |
| X124 | 7.29 | Z056 | 10.12 |
| X125 | 7.27, 7.29 | Z057 | 1.24, 10.12 |
| X137 | 7.40 | Z058 | 10.12, 13.43 |
| X139 | 7.42 | Z059 | 10.12 |
| X500 - X501 - X502 - X503 | 9.26 | Z060 | 10.12, 11.06 |
| X505 - X506 | 9.26 | Z060KD |  11.09 |
| X508 - X509 | 9.26 | Z060 THREADED RINGS | 10.12 |
| X510 | 9.27 | Z080 - Z081 | 11.11 |
| X512 | 9.27 | Z090 | 10.13 |
| X520 - X521 | 9.27 | Z091 | 7.31, 7.32, 10.13, 10.14 |
| X522 - X523 | 9.27 | Z092 | 7.33, 10.14 |
| X528 | 9.28 | Z155 | 11.04, 11.05 |
| X530 - X531 | 9.28 | Z255 | 11.04, 11.05 |
| X532 - X533 | 9.28 | Z355 | 11.04, 11.05 |
| X540 - X541 | 9.28 | Z455 | 11.04÷11.06 |
| X900 | 14.08 | Z455KD |  11.09 |
| X901 | 14.08 | Z555 | 11.04, 11.05 |
| X902 | 14.09 | ZA000 | 10.14, 12.38 |
| X903 | 14.09 | ZA010 | 10.15, 13.44 |
| X904 | 14.09 | ZA011 | 10.15, 13.44 |
| X905 | 14.09 | ZB | 11.11 |
| X920 | 14.09 | ZC 30 - ZC 35 | 11.12, 11.13 |
| X921 | 14.09 | ZC 50 - ZC 60 - ZC 70 | 11.14 |
| X922 | 14.10 | ZE | 11.15÷11.17 |
| X923 | 14.10 | ZINKEL | 16.03 |
| X930 | 14.10 | | |
| X940 | 14.10 | | |
| X950 | 14.10 | | |
| XAH | 9.29, 12.13 | | |

General sale conditions

Unless otherwise agreed in writing

ORDERS

Whether direct or indirect, these are only accepted with our approval and irrevocable on the part of the purchaser.

PRICES

Are only a guide and are not binding. Those correct at the time of forwarding will be applied.

Prices for special tools may be varied at any time to allow for increased costs of materials and manufacturing as well as any further costs arising during the time taken to execute the order.

PACKAGING

Is always invoiced at cost price.

FORWARDING

Ex-factory (Pesaro). Goods always travel at the purchaser's risk. In the case of forwarding by postal service, Sistemi s.r.l. can accept no responsibility for goods which fail to arrive at destination or which arrive damaged in any way.

DELIVERY

Is not binding and therefore, apart from our company being exonerated from any claims, it is implicitly dependent upon the supply of raw materials as well as any production difficulties arising due to events beyond our control.

GARANTEE

Under conditions of normal usage we undertake to replace tools we consider to be defective.

This guarantee does not extend to tools showing normal wear and tear, evidence of damage or tools which have been used incorrectly.

CLAIMS

Must be made in writing within 8 days upon receipt of goods. If the claim is made within the specified limits, is valid and justified, the purchaser has the exclusive right to substitution of good or credit for the same amount, excluding any other indemnity from the company.

SMALL ORDERS

For administrative reasons the minimum order value is set at 100,00 €.

SPECIAL TOOLS

In cases where these are specifically requested, the order carried out may involve quantities higher or lower than those specified in the order, depending on the number of items.

PAYMENT TERMS

Must be made directly to our head office in the form agreed. If payment is delayed for any reason, interest at bank rates will accrue from the date payment is due, including any eventual further expenses.

JURISDICTION

In the case of any legal contention the Court of PESARO will have full power of jurisdiction.

Klein

Klein

Klein

Klein

Klein

Klein

Klein



Klein[®]

SISTEMI S.r.l. • 61122 PESARO - Italy - Via Montanelli, 70
Tel. +39.0721.28950 • Fax +39.0721.283476
www.sistemiklein.com • info@sistemiklein.com

